

CONSTRUCTION OF FUEL DISPENSING FACILITY AT BUILDING E-413

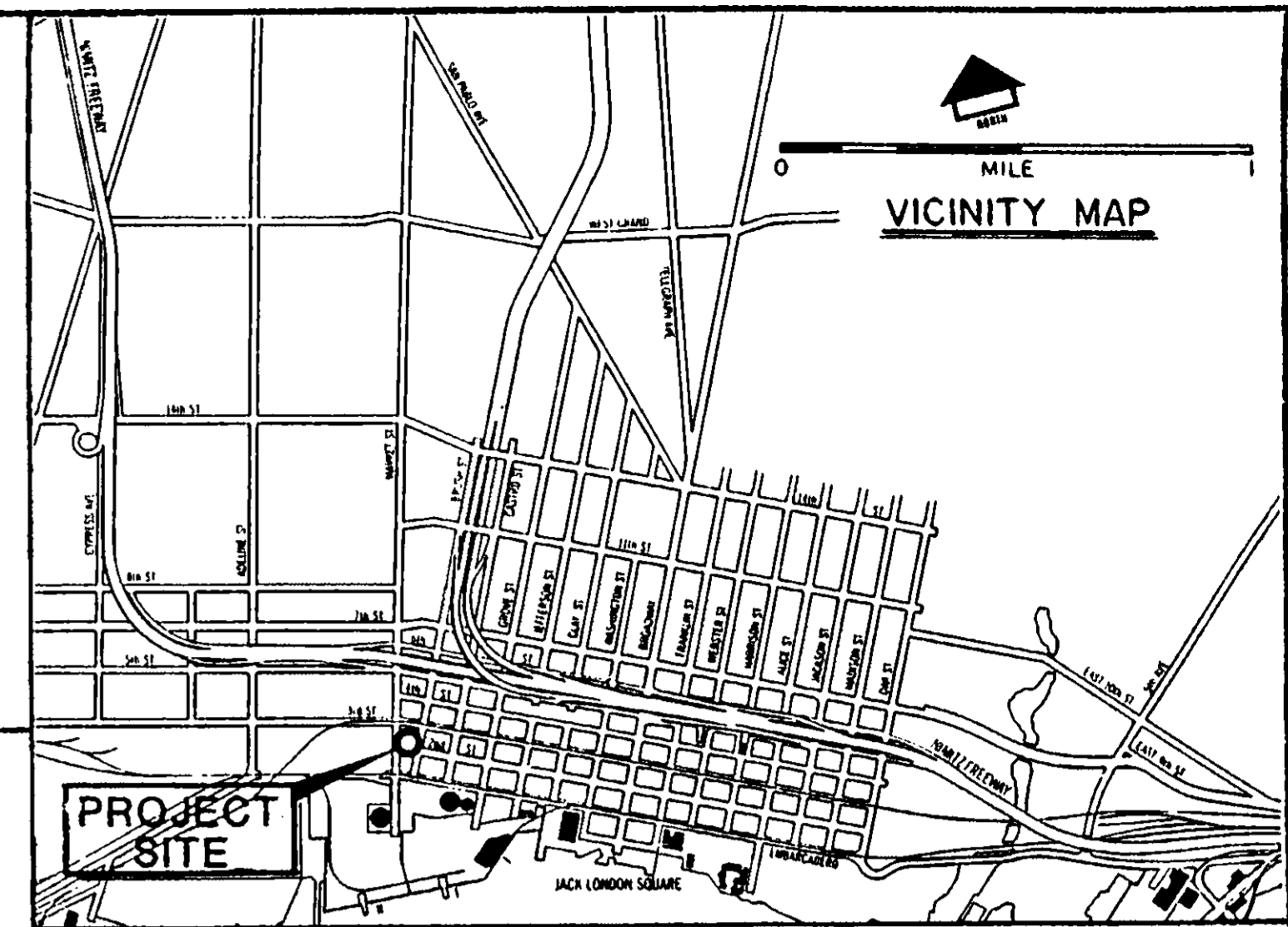

INDEX OF DRAWINGS

1. TITLE SHEET
2. EXISTING CONDITIONS
3. PLAN AND SECTIONS
4. FUELING FACILITY PLAN
5. FUELING ISLAND INSTALLATION & DETAILS
6. FUEL STORAGE TANK INSTALLATION DETAILS

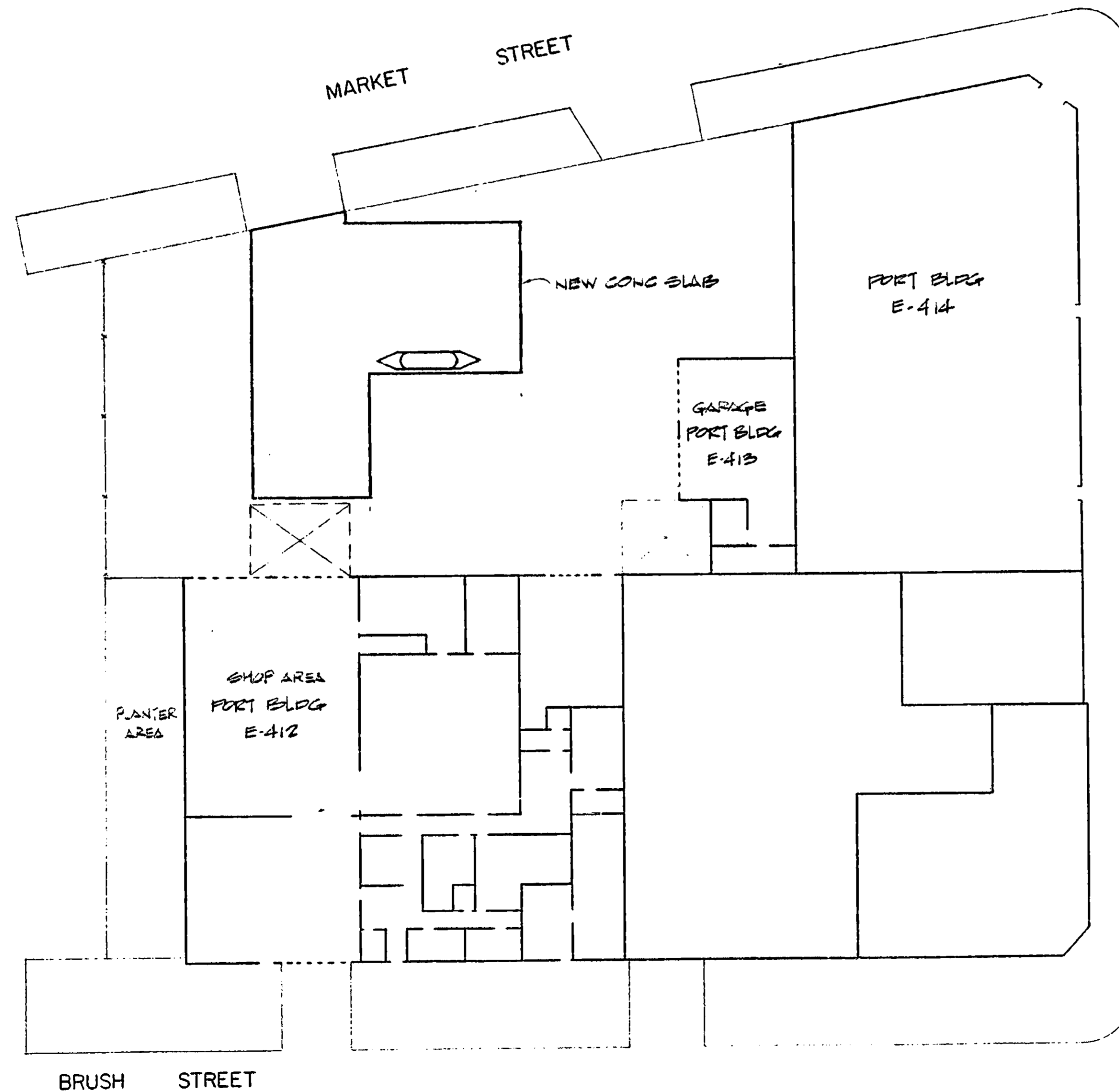
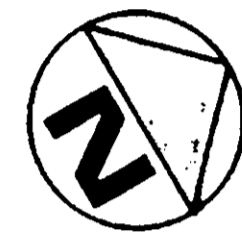

LOCATION PLAN
SCALE: 1" = 20'

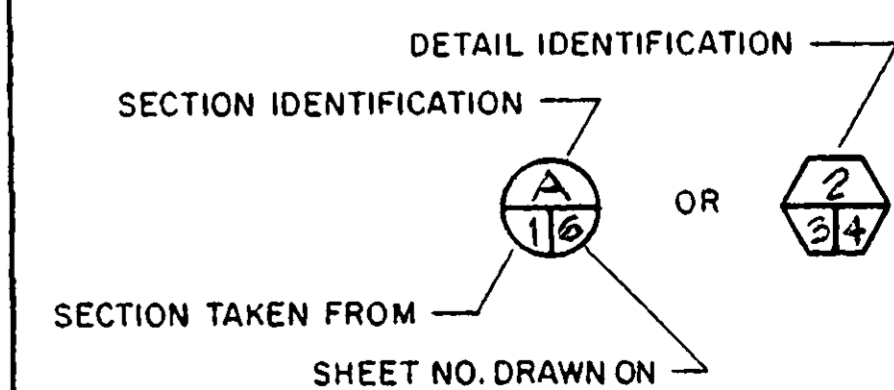

CAUTION

THIS PLAN MAY
BE REDUCED

DO NOT SCALE

0 1" 2"
ORIGINAL SCALE

REFERENCES

PLANS
FIELD BOOKS

"PORT OF OAKLAND DATUM"
IS 3.20' BELOW MEAN SEA LEVEL

NO.	REVISIONS	DATE	APP'D

REVIEWED: <i>J. Daniels</i>	DRAWN: <i>F TEE EL</i>
REVIEWED: <i>Ray A. Clark</i>	DESIGNED: <i>Ala. Benham</i> C22241
REVIEWED: <i>John...</i>	CHECKED: <i>RDG</i>
	REVIEWED: <i>W. J. ...</i> C20264

PORT OF OAKLAND

66 JACK LONDON SQ. OAKLAND, CALIFORNIA

CHIEF ENGINEER	C22138
<i>[Signature]</i>	REG. ENGINEER NO.
APPROVED	C13202
<i>[Signature]</i>	REG. ENGINEER NO.
RECOMMENDED	C10597
<i>[Signature]</i>	REG. ENGINEER NO.

INNER HARBOR
CONSTRUCTION OF FUEL DISPENSING FACILITY
AT BUILDING E-413

TITLE SHEET

DATE: JUL 10, 1986
SCALE: 1" = 20'
SHEET 1 OF 6 SHEETS
FILE AA-2621



MARKET ST

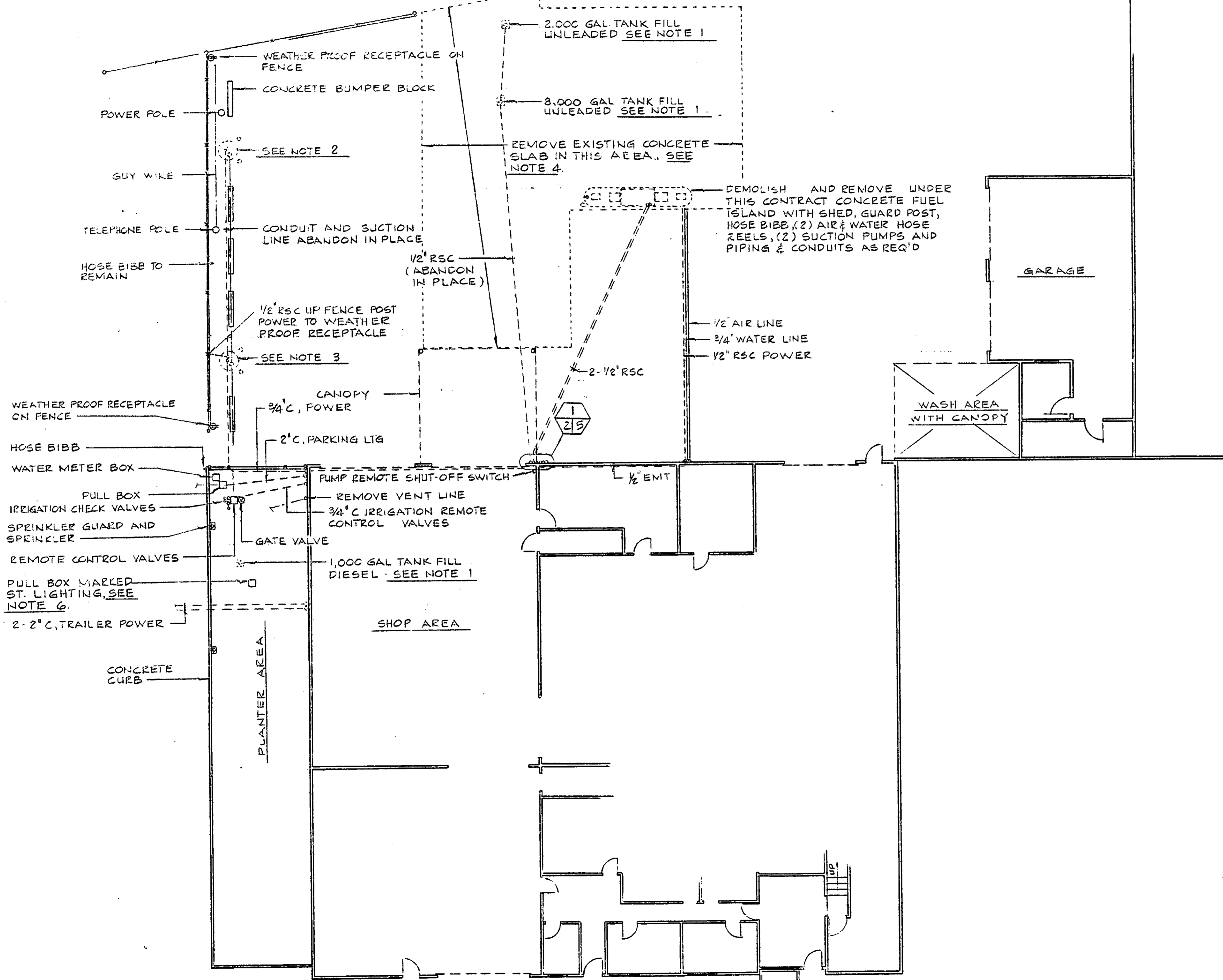

- Notes:
1. EXACT UNDERGROUND TANKS, PIPING, CONDUIT LOCATION AND OTHER UTILITIES TO BE DETERMINED IN FIELD. REMOVAL OF UNDERGROUND TANKS, PIPING AND CONDUITS PER SPECIFICATIONS. SEE SPEC REGARDING USE OF EXISTING 1,000 GAL TANK FOR FUELING PURPOSES DURING REMOVAL & INSTALLATION OF NEW TANKS.
 2. DEMOLISH AND REMOVE UNDER THIS CONTRACT, CONCRETE PADS, CONCRETE FUEL ISLAND, GUARD POSTS AND SECTION PUMP, CUT AND CAP SUCTION LINE AND CONDUITS BELOW FINISHED GRADE. PATCH WITH CONCRETE TO MATCH EXISTING.
 3. DEMOLISH AND REMOVE UNDER THIS CONTRACT, CONCRETE PADS, CONCRETE FUEL ISLAND, GUARD POSTS AND CUT AND CAP SUCTION LINE BELOW FINISHED GRADE. EXTEND 3/4\" RSC AS SHOWN AND NOTED ON SHEET 4 AND PATCH WITH CONCRETE TO MATCH EXISTING.
 4. EXISTING CONCRETE SLAB SHALL BE DEMOLISHED, AND REMOVED UNDER THIS CONTRACT BEFORE INSTALLING NEW SLAB, SEE PLAN, SHEET 3 FOR JOINT DETAILS.
 5. ALL EXISTING SHOWN ON PLAN TO REMAIN UNLESS OTHERWISE NOTED.
 6. HAND DIG TO LOCATE PULL BOX MARKED STREET LIGHT.

BRUSH ST.
 PLAN
 SCALE 1" = 10'

CAUTION
 THIS PLAN MAY BE REDUCED
 DO NOT SCALE
 ORIGINAL SCALE

NO.	REVISIONS	DATE	APP'D

REVIEWED	<i>[Signature]</i>	DRAWN	<i>[Signature]</i>
REVIEWED	<i>[Signature]</i>	DESIGNED	<i>[Signature]</i>
REVIEWED	<i>[Signature]</i>	CHECKED	<i>[Signature]</i>
		REVIEWED	<i>[Signature]</i>

PORT OF OAKLAND
 66 JACK LONDON SQ. OAKLAND, CALIFORNIA

CHIEF ENGINEER	<i>[Signature]</i> C 22138
APPROVED	<i>[Signature]</i> E 8351
RECOMMENDED	<i>[Signature]</i> E 8351

INNER HARBOR
 CONSTRUCTION OF FUEL DISPENSING FACILITY AT BUILDING E-413
 EXISTING CONDITIONS

DATE	JULY 10, 1986
SCALE	AS NOTED
SHEET	2 OF 6 SHEETS
FILE	AA-2621

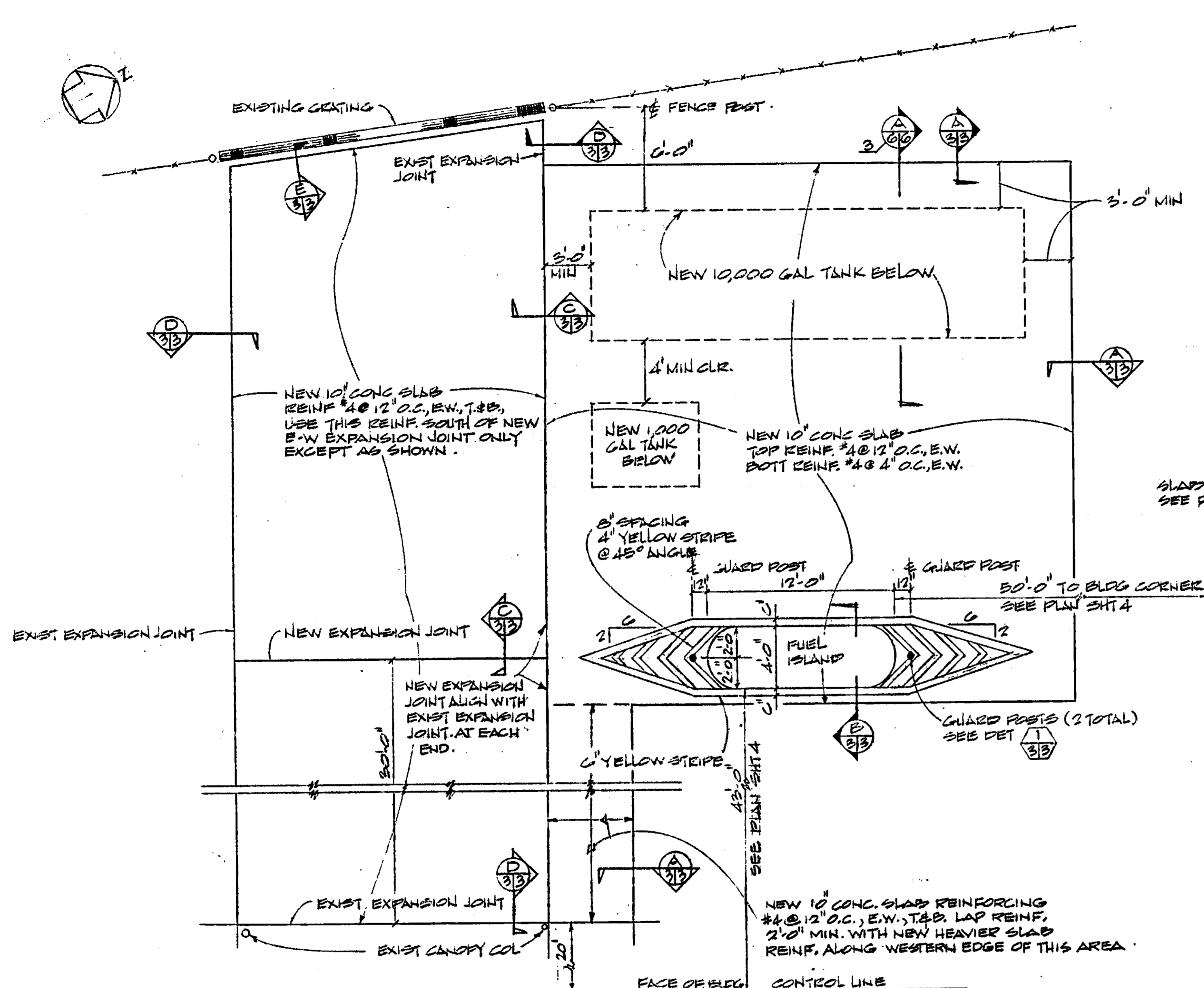

PARTIAL YARD PLAN
N.T.S.

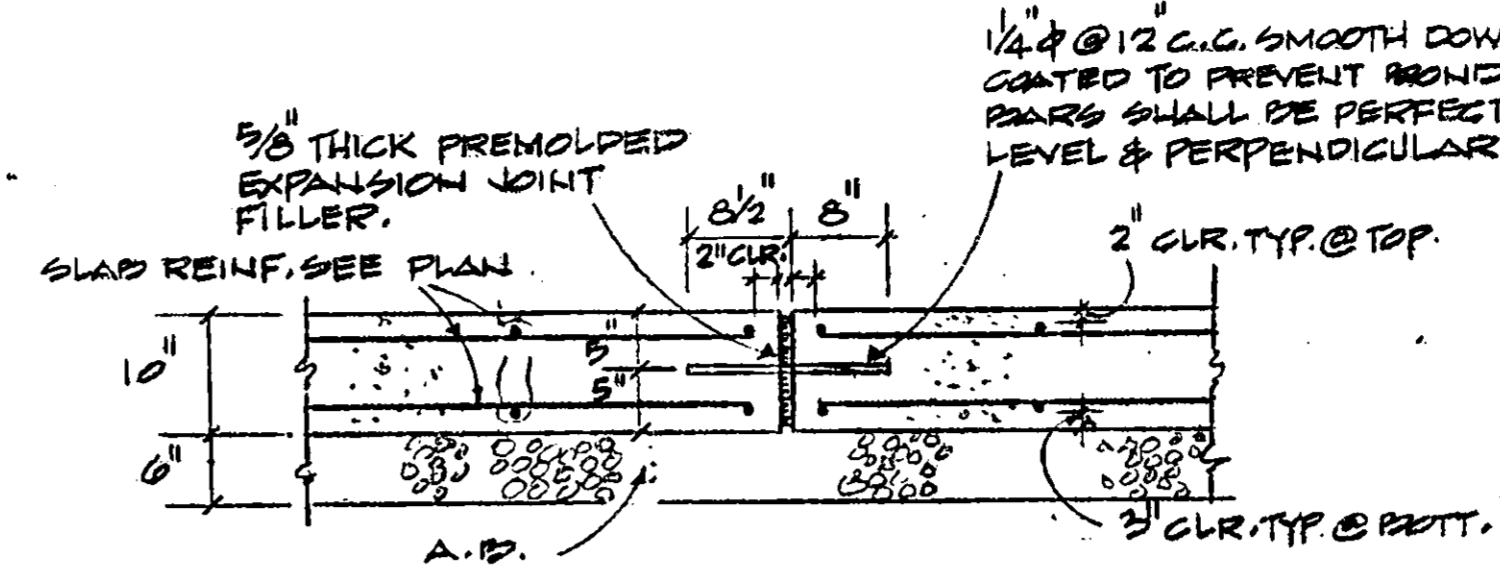

SECTION C
SCALE 3/4\"/>

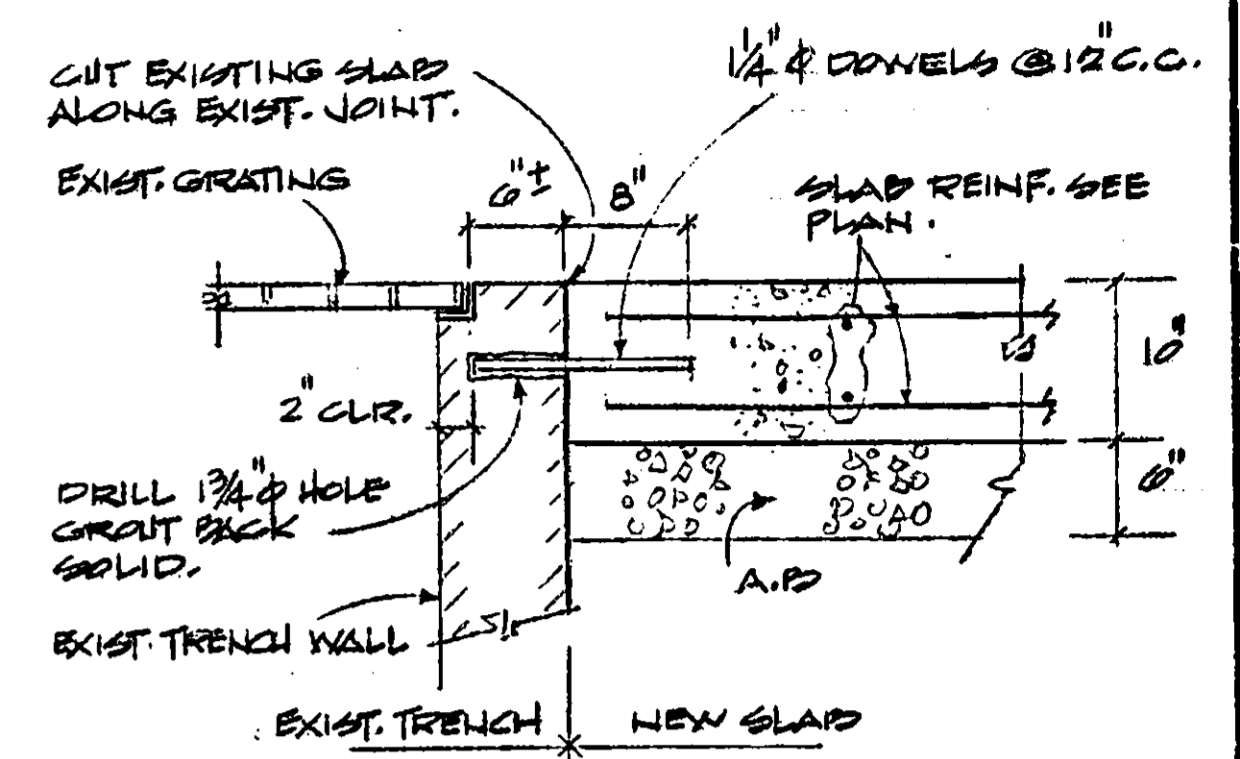

SECTION E
SCALE 1\"/>

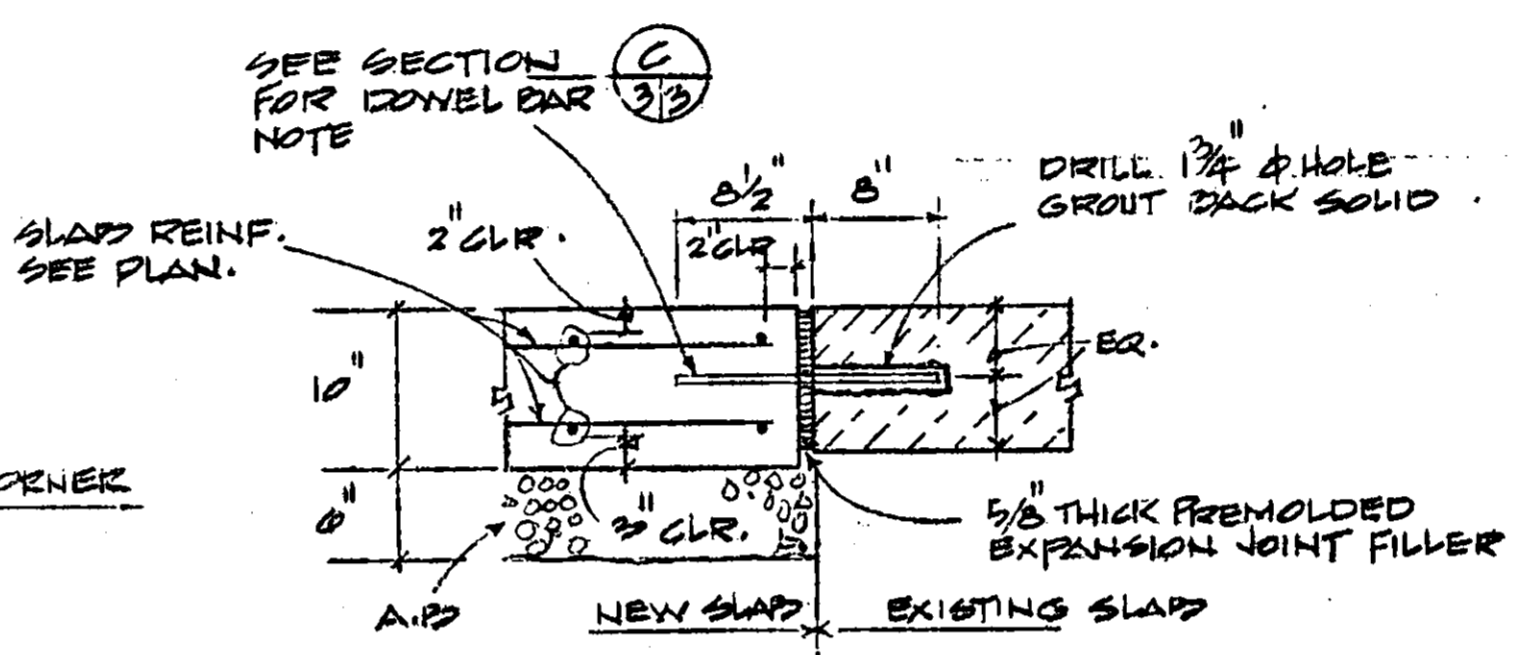

SECTION D
SCALE 1\"/>

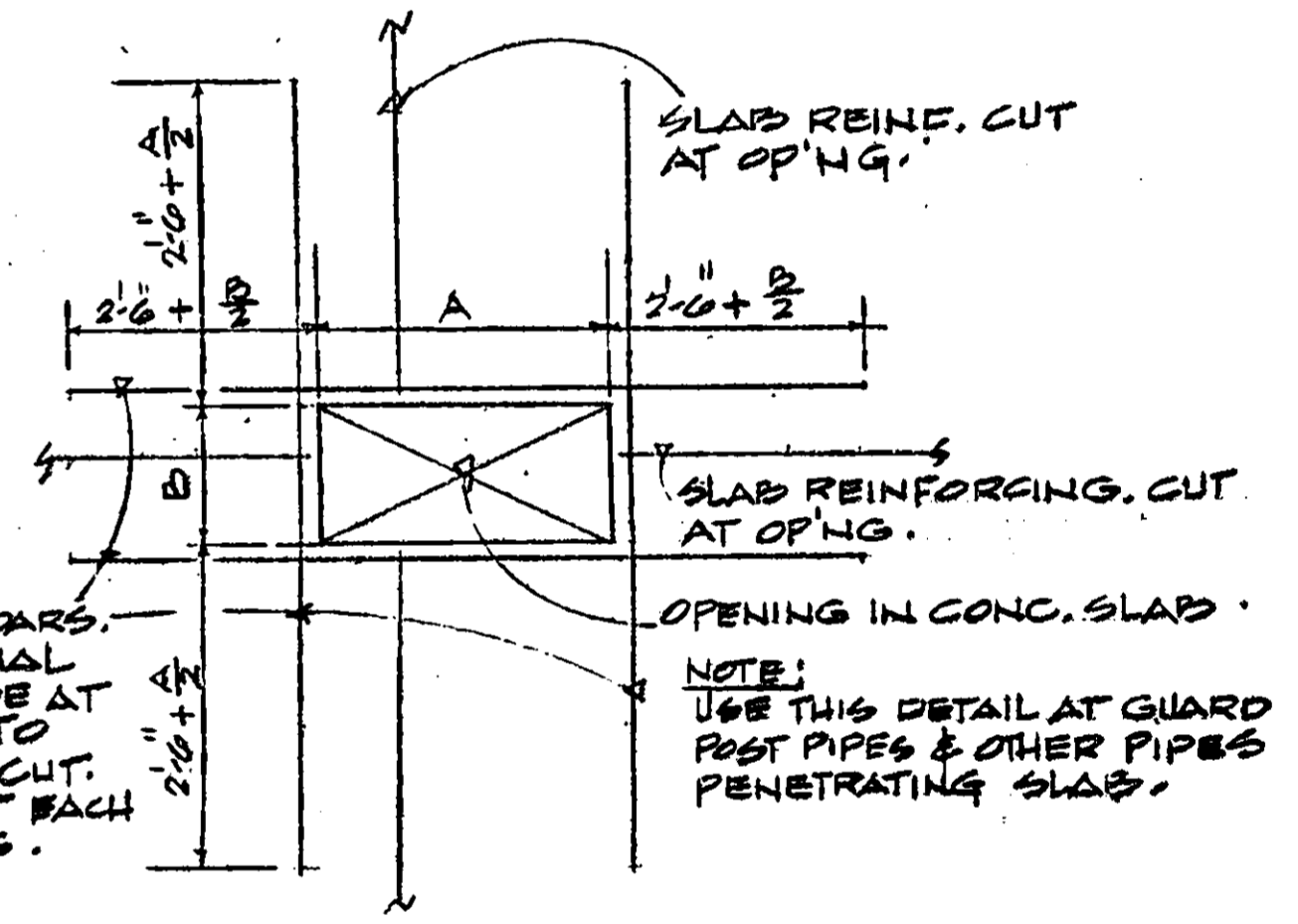

TYPICAL DETAIL PLAN FOR EXTRA SLAB REINFORCING AT OPENINGS IN CONC. SLAB
N.T.S.

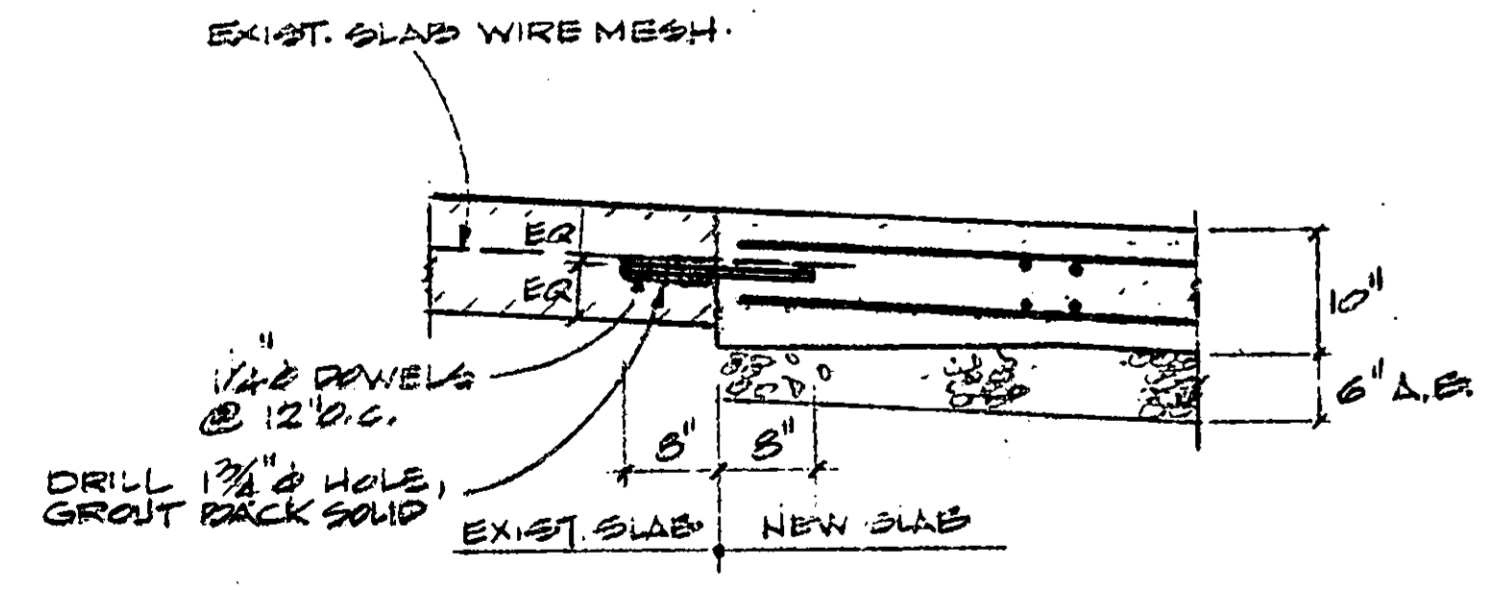

CONNECTION BETWEEN EXIST. SLAB & NEW SLAB

SECTION A
SCALE 3/4\"/>

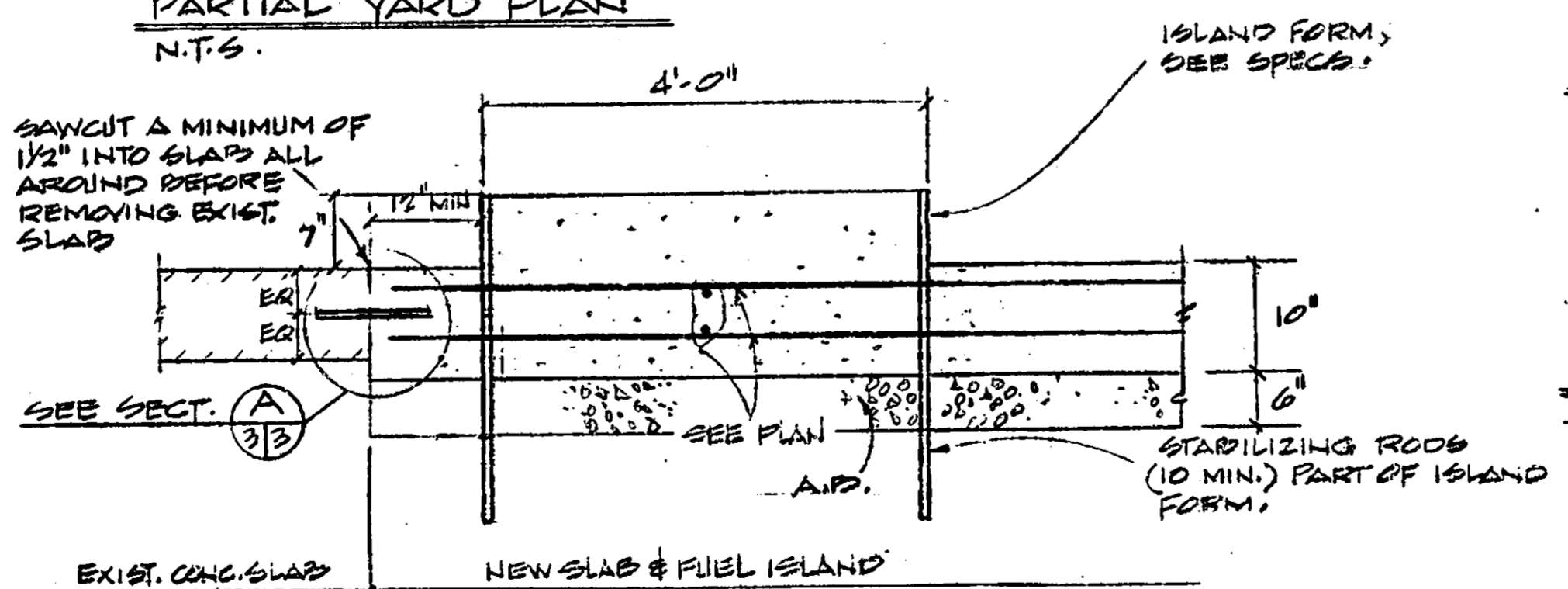

FUEL ISLAND SECTION
SCALE 3/4\"/>

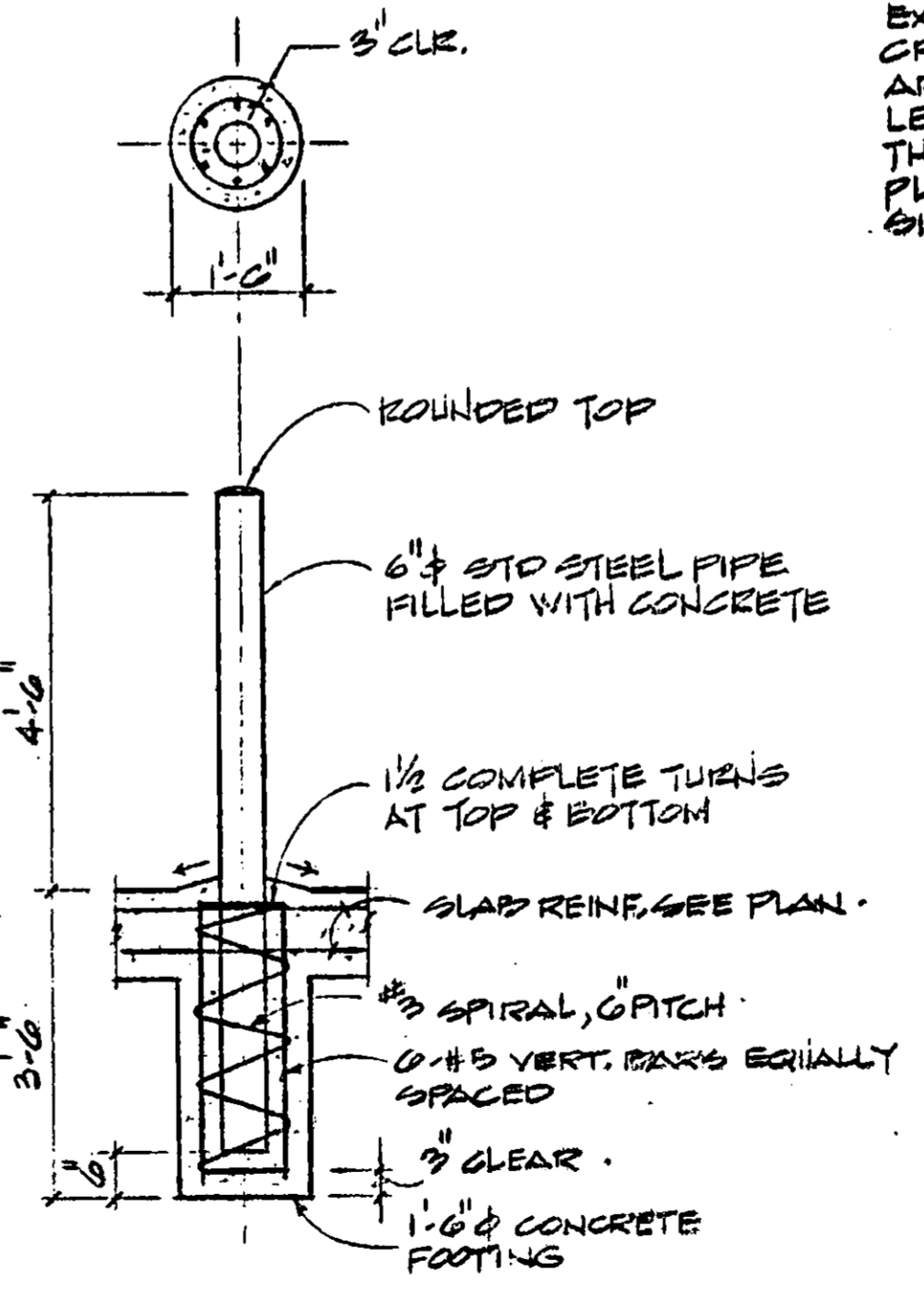

TYPICAL GUARD POST DETAIL
SCALE 1/2\"/>

- NOTES:**
1. SPLICES IN REINF. SHALL BE IN ACCORDANCE WITH ACI-CODE.
 2. STAGGER SPLICES SO NO MORE THAN HALF THE BARS ARE SPLICED AT THE SAME POINT.

CAUTION

THIS PLAN MAY BE REDUCED
DO NOT SCALE

ORIGINAL SCALE

NO.	REVISIONS	DATE	APP'D

REVIEWED: <i>J. H. ...</i>	DRAWN: EL CNG
REVIEWED: <i>...</i>	DESIGNED: <i>...</i>
REVIEWED: <i>...</i>	CHECKED: <i>...</i>
	REVIEWED: <i>...</i>

PORT OF OAKLAND
66 JACK LONDON SQ. OAKLAND, CALIFORNIA

CHIEF ENGINEER: <i>J. P. ...</i>	REG. ENGINEER NO. C22136
APPROVED: <i>...</i>	REG. ENGINEER NO. C13202
RECOMMENDED: <i>...</i>	REG. ENGINEER NO. C10597

INNER HARBOR
CONSTRUCTION OF FUEL DISPENSING FACILITY AT BUILDING E-413
PLAN & SECTIONS

DATE: JUL 10, 1986
SCALE: AS SHOWN
SHEET: 3 OF 6 SHEETS
FILE: AA-2621



MARKET ST.

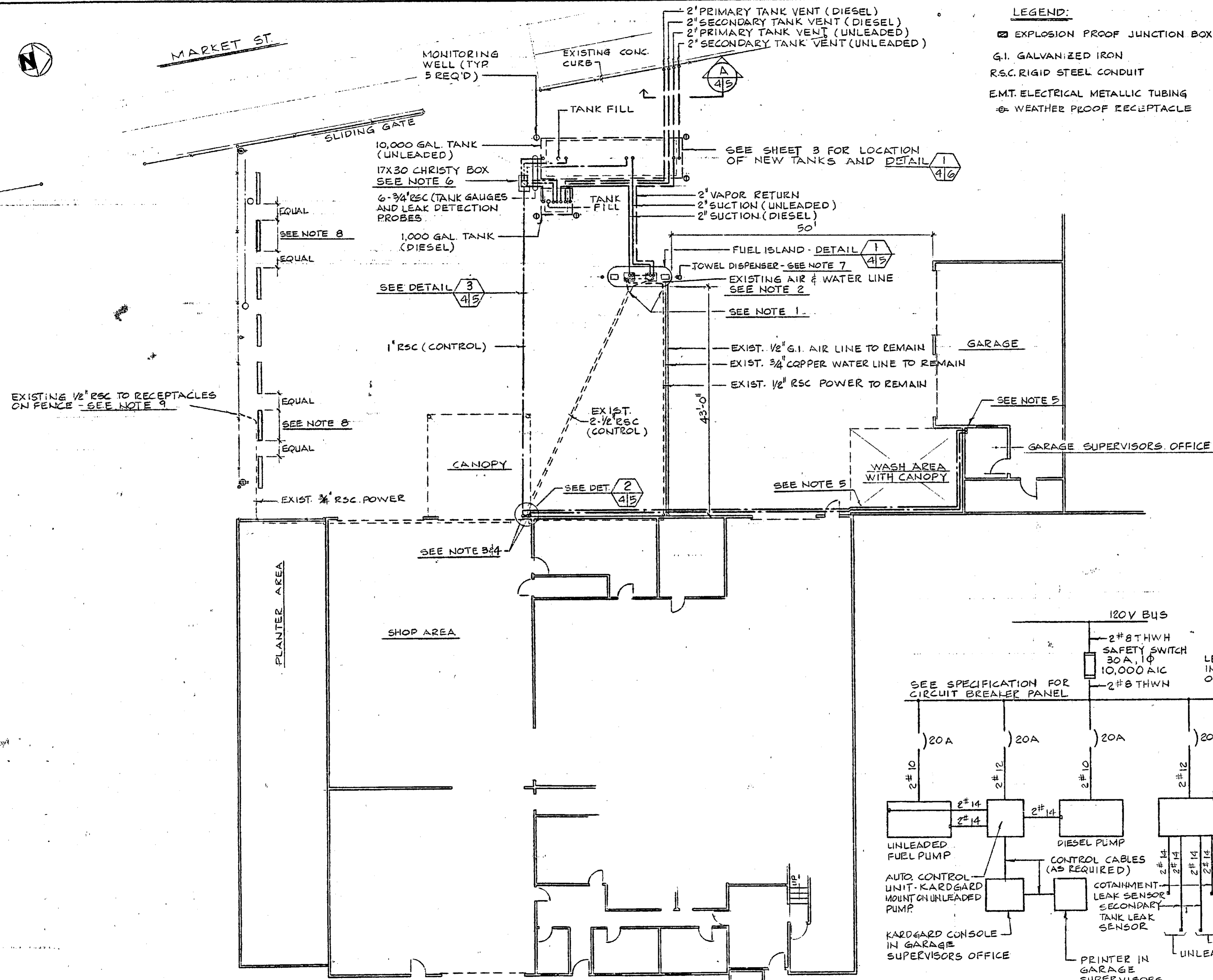

LEGEND:
 EXPLOSION PROOF JUNCTION BOX
 G.I. GALVANIZED IRON
 R.S.C. RIGID STEEL CONDUIT
 E.M.T. ELECTRICAL METALLIC TUBING
 WEATHER PROOF RECEPTACLE

NOTES:

1. CONNECT NEW 1/2" RSC TO EXISTING 1/2" RSC AND EXTEND TO NEW FUELING ISLAND FOR PUMP POWER AND CONTROL CONDUITS.
2. EXTEND EXISTING 1/2" G.I. AIR & 3/4" COPPER WATER LINES TO NEW AIR & WATER HOSE REELS AT BOTH ENDS OF ISLAND. (PIPING FOR AIR & WATER TO HOSE REELS NOT SHOWN FOR CLARITY)
3. REMOVE EXISTING CONDUIT FITTINGS AND INSTALL NEW EXPLOSION PROOF JUNCTION BOX.
4. EXTEND NEW 1" RSC CONDUITS UP OUTSIDE WALL OF BUILDING TO A HEIGHT ABOVE WINDOWS AND ROLL UP DOORWAYS ALONG WALL TO WASH AREA.
5. WASH AREA INSTALL CONDUITS BELOW CANOPY ON WALL AND CORE DRILL HOLES THROUGH WALL INTO GARAGE OFFICE. CONDUIT TO BE WITHIN 12" OF FLOOR. PROVIDE BUSHING ON CONDUITS. COORDINATE WITH ENGINEER FOR EXACT LOCATION OF INSTALLATION OF ELECTRONIC EQUIPMENT.
6. NEW H2O LOADING 17X30 PULL BOX WITH COVER. CHRISTY PULLBOX B1730 BOX, STEEL CHECKER COVER B1730-SUH. CONTAINS EXPLOSION PROOF JUNCTION BOX.
7. MULTI-FOLD PAPER TOWEL DISPENSER WEATHER TIGHT FOR OUT OF DOORS USE. SECURE TOWEL DISPENSER TO GUARD POST
8. INSTALL (2) NEW 6' LONG PRECAST CONCRETE BUMPER TO MATCH EXISTING EPOXY BUMPER IN PLACE.
9. AFTER REMOVAL OF PUMP PAD. EXTEND EXISTING 3/4" RSC BELOW GRADE AND MAKE CONNECTION TO EXISTING 1/2" RSC TO RECEPTACLES ON FENCE. INSTALL JUNCTION BOX FOR CONNECTION OF EXTENDED 3/4" RSC TO 1/2" RSC ON FENCE

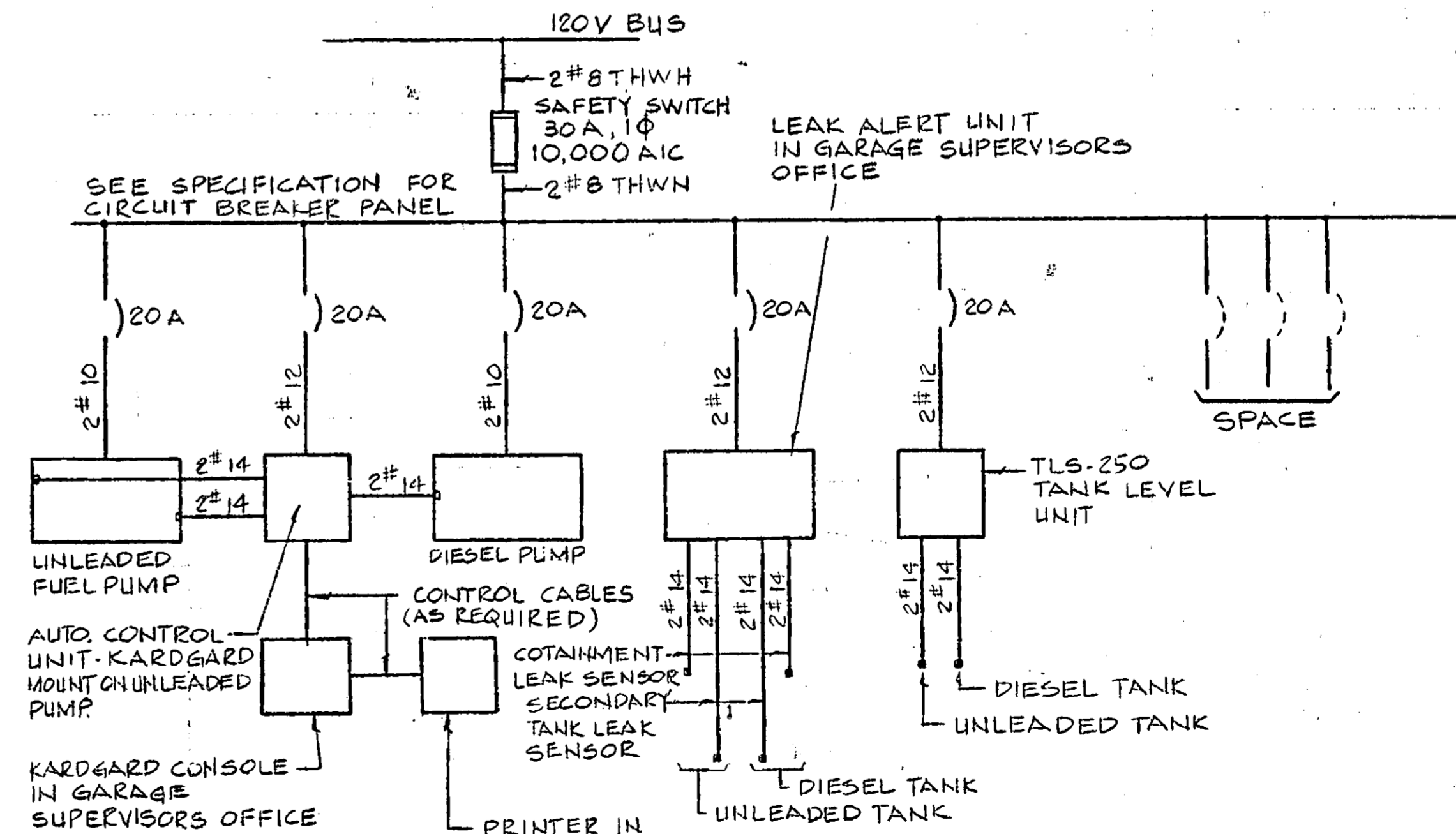

PLAN
SCALE 1"=10'

SINGLE LINE DIAGRAM

CAUTION

THIS PLAN MAY BE REDUCED

DO NOT SCALE

ORIGINAL SCALE

NO.	REVISIONS	DATE	APP'D

PORT OF OAKLAND
 66 JACK LONDON SQ. OAKLAND, CALIFORNIA

CHIEF ENGINEER
[Signature] C22138
 APPROVED
 RECOMMENDED

INNER HARBOR
 CONSTRUCTION OF FUEL DISPENSING FACILITY AT BUILDING E-413
 INSTALLATION OF FUEL FACILITY

DATE JULY 10, 1986
 SCALE AS NOTED
 SHEET 4 OF 6 SHEETS
 FILE AA-2621

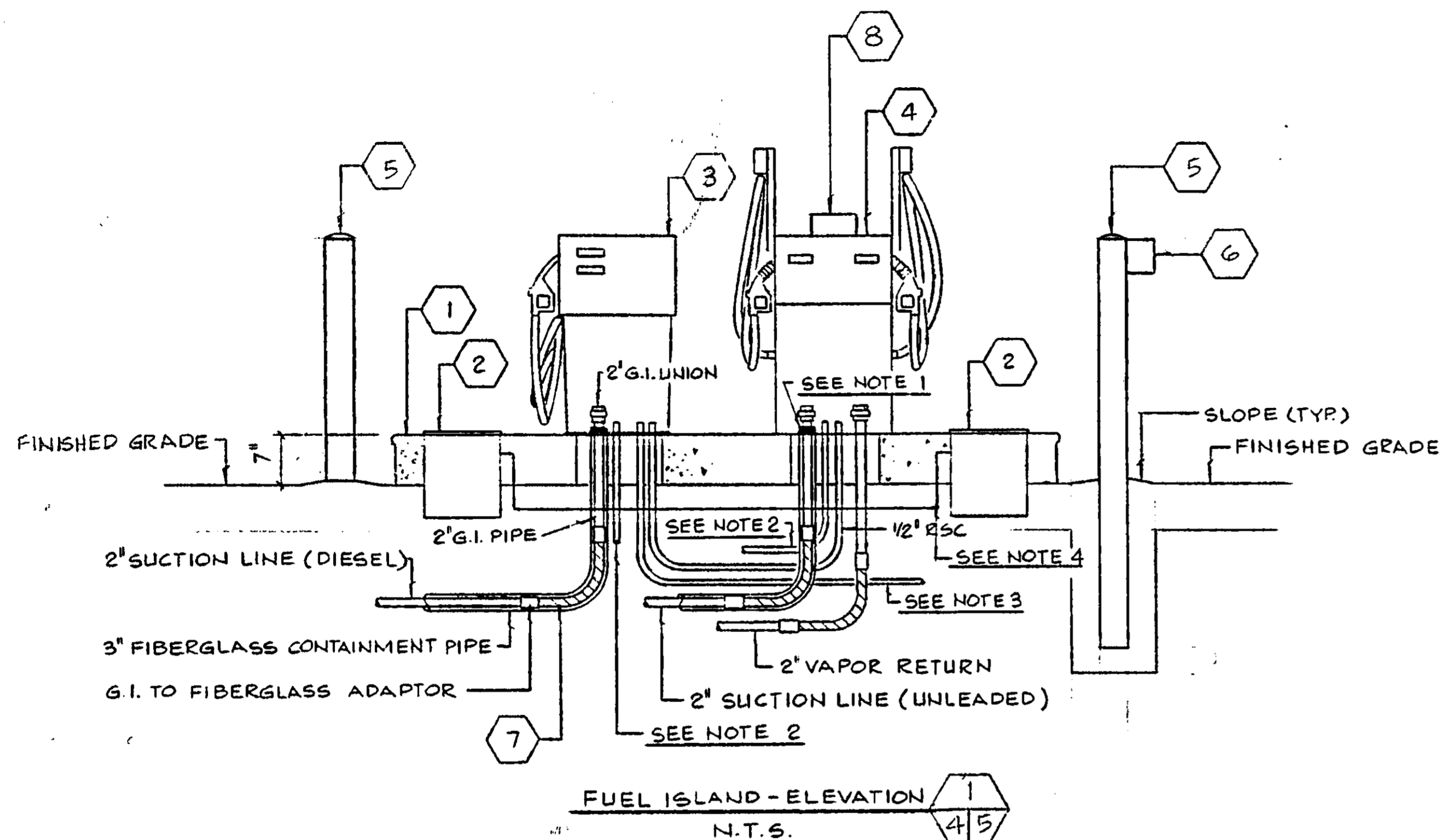

FUEL ISLAND - ELEVATION
N.T.S.

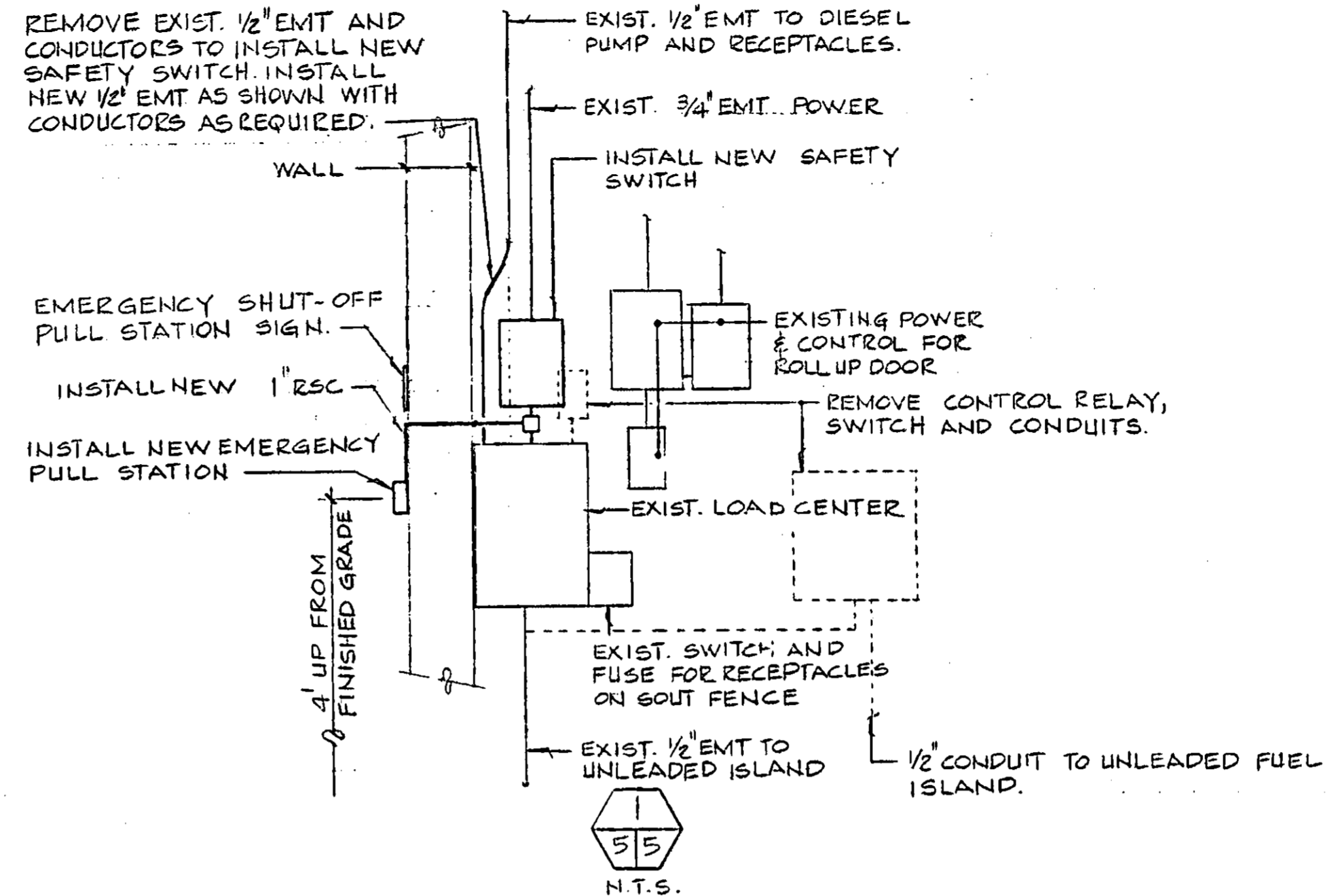

- NOTES:
1. REMOVE VENT LINES CUT AND CAP FLUSH WITH FINISHED GRADE.
 2. REMOVE EXISTING CONDUIT FITTINGS AND INSTALL NEW EXPLOSION PROOF JUNCTION BOX.
 3. EXTEND NEW 1" RSC CONDUITS UP OUTSIDE WALL OF BUILDING TO A HEIGHT ABOVE WINDOWS AND ROLL-UP DOORWAYS ALONG WALL TO WASH AREA.

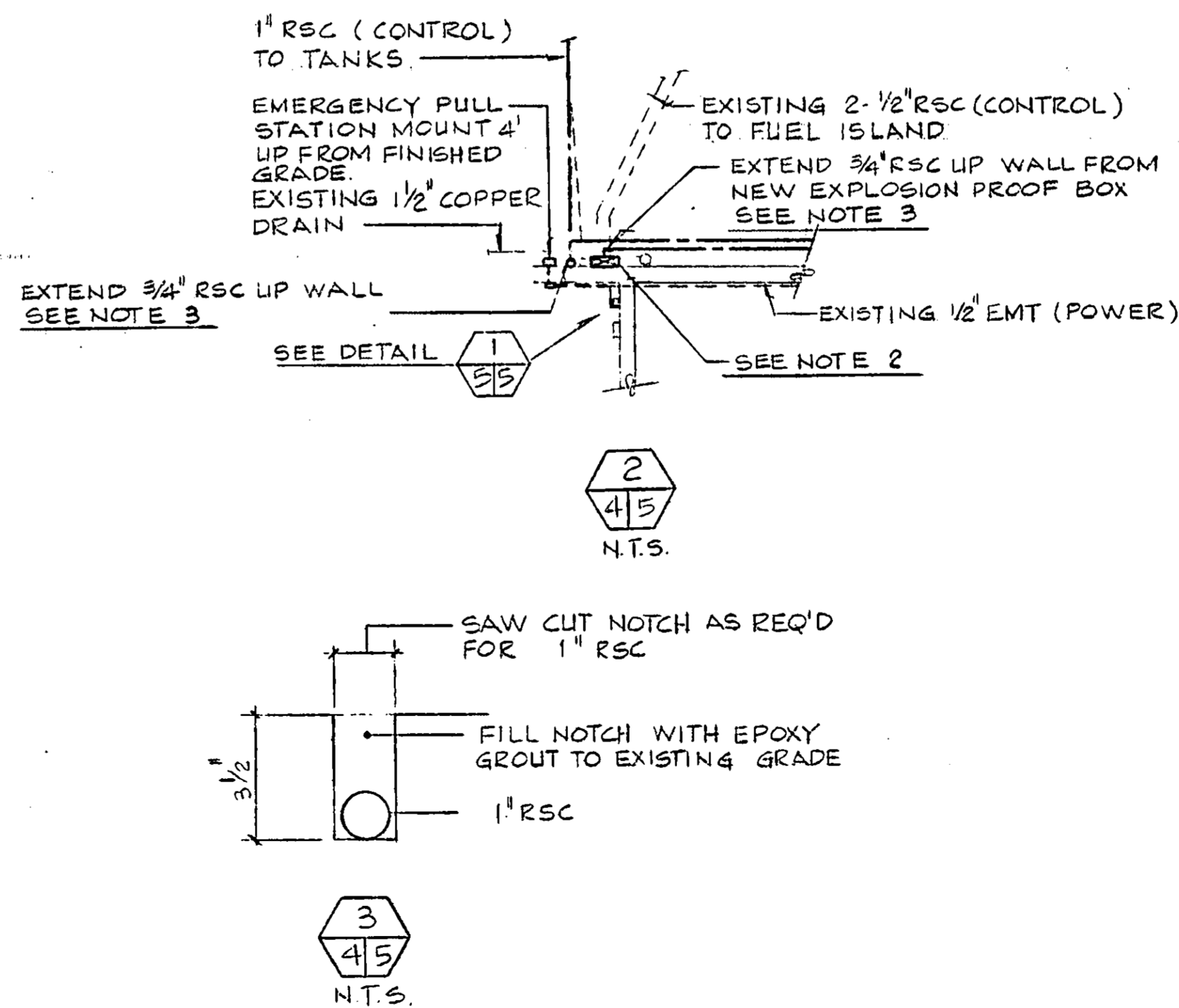
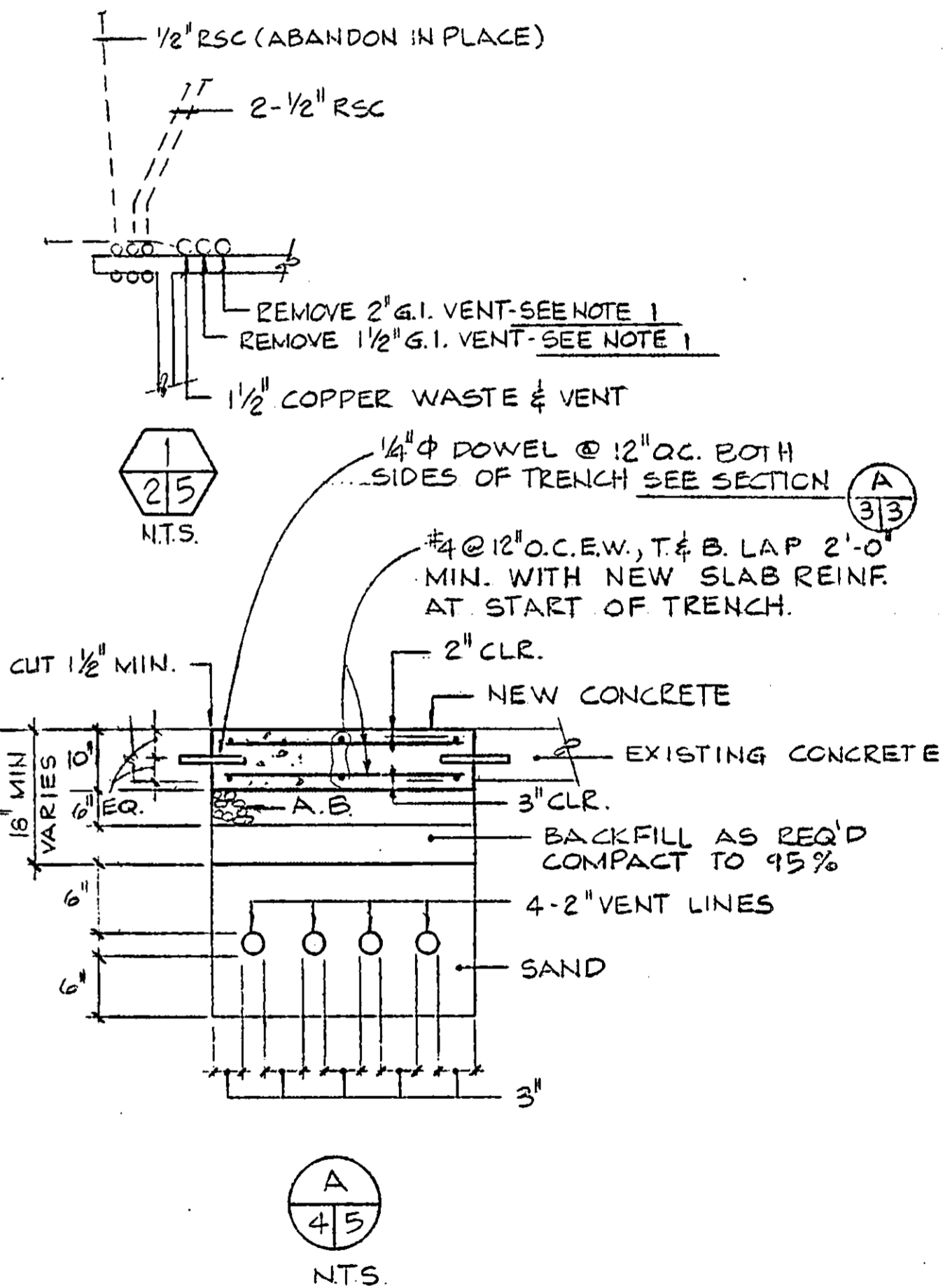

EQUIPMENT SCHEDULE	
ITEM DESIG	DESCRIPTION
1	FUEL ISLAND-COXWELL 48FI2 WITH PRE-FAB END SECTIONS 48HC, 5 CROSS BRACES AND 8 STABILING ANCHOR RODS SIZE PER MANUFACTURER, FILL WITH CONCRETE.
2	UNDERGROUND AIR & WATER SELF-RETRACTING HOSE REEL ASSEMBLY WITH PAD LOCKING COVER-COXWELLS CRU-135-135; TIRE INFLATOR HEAVY DUTY TIRE GAUGE-AMFLO 101 DUAL FOOT CHUCK; RADIATOR FAUCET-AMFLO 40R RUBBER SPOUT (2 REQ'D).
3	REFURBISH AND INSTALL ONE OF THE EXISTING SUCTION PUMP, ON NEW FUEL DISPENSING ISLAND AS DIRECTED BY PORT ENGINEER. REFURBISHED PUMP TO BE USED FOR DIESEL FUEL.
4	NEW UNLEADED SUCTION PUMP-TOKHEIM SERIES 785 I-TW-PR, 1/2 HP, 115/230V, 1φ COMMERCIAL SUCTION PUMP WITH HIGH HOSE RETRIEVER SYSTEM WITH VAPOR RETURN SYSTEM
5	GUARD POSTS 6"φ SCH. 40 GALV STEEL 7'-6" LENGTH WITH 18"φ CONCRETE BASE AND FILL GUARD POSTS WITH CONCRETE AND FORM DOME (2 REQ'D) SEE DETAIL 1/313
6	WEATHER PROOF TOWEL DISPENSER FOR MULTIFOLD PAPER TOWELS SECURE TOWEL DISPENSER TO GUARD POST AS DIRECTED BY PORT ENGINEER.
7	STAINLESS STEEL TEFLON LINED 2"φ x 24" LENGTH TELEFLEX
8	AUTO CONTROL UNIT-KARDGARD 300CL, MOUNT ON UNLEADED FUEL PUMP

- NOTES: FOR FUEL ISLAND DETAIL
1. MAKE WATER TIGHT CONNECTION AROUND 2" G.I. PIPE RISER WITH 3" FIBERGLASS CONTAINMENT PIPE
 2. CONNECT NEW 1/2" RSC TO EXISTING 1/2" RSC, SEE PLAN (CONTROL)
 3. CONNECT NEW 1/2" RSC TO EXISTING 1/2" RSC, SEE PLAN (POWER)
 4. AIR AND WATER LINES ARE NOT SHOWN FOR CLARITY. CONNECT NEW 1/2" AIR AND 3/4" WATER COPPER LINES TO EXISTING LINES.

NO.	REVISIONS	DATE	APP'D

REVIEWED: <i>J. Daniels</i>	DRAWN: <i>[Signature]</i>
REVIEWED: <i>[Signature]</i>	DESIGNED: <i>[Signature]</i>
REVIEWED: <i>[Signature]</i>	CHECKED: <i>[Signature]</i>
	REVIEWED: <i>[Signature]</i>

PORT OF OAKLAND
66 JACK LONDON SQ. OAKLAND, CALIFORNIA

CHIEF ENGINEER
[Signature] C22138
APPROVED: *[Signature]* M13936
RECOMMENDED: *[Signature]*

CONSTRUCTION OF FUEL DISPENSING FACILITY AT BUILDING E-413
FUEL ISLAND INSTALLATION & DETAILS

DATE: JULY 10, 1986
SCALE: 5 OF 6 SHEETS
FILE: AA-2621

CAUTION
THIS PLAN MAY BE REDUCED
DO NOT SCALE

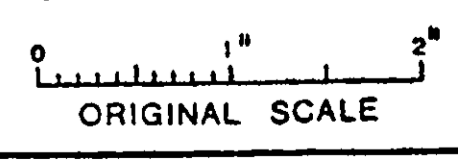

CAUTION - CHECK TRACING FOR LATEST REVISIONS

NOTES:

1. DEPTH OF TANK AS REQUIRED TO MAINTAIN SPECIFIED DEPTH OF HORIZONTAL PRODUCT, VAPOR AND VENT PIPING. PRODUCT, VAPOR AND VENT PIPING SHALL SLOPE UP FROM TANK A MINIMUM OF 1/8" PER FOOT.
2. INSTALLATION OF MULTIPLE TANKS 4'-0" MIN. SPACE BETWEEN TANKS. 12" MIN. EXCAVATION ALL AROUND TANK.
3. VAPOR RECOVERY NOT REQUIRED FOR DIESEL FUEL.
4. PROVIDE HOLD DOWN STRAPS AS REQUIRED BY TANK MANUFACTURER.
5. ACTUAL SHAPE & SIZE OF DEADMAN TO BE PROPOSED IN SHOP DRAWING SUBMITTAL. THIS SUBMITTAL SHALL ALSO INCLUDE DEADMAN CALC'S, SEE SPEC'S. DEADMAN SIZE AND REINFORCING SHOWN ON THIS DRAWING IS MIN. REQUIREMENT ONLY.

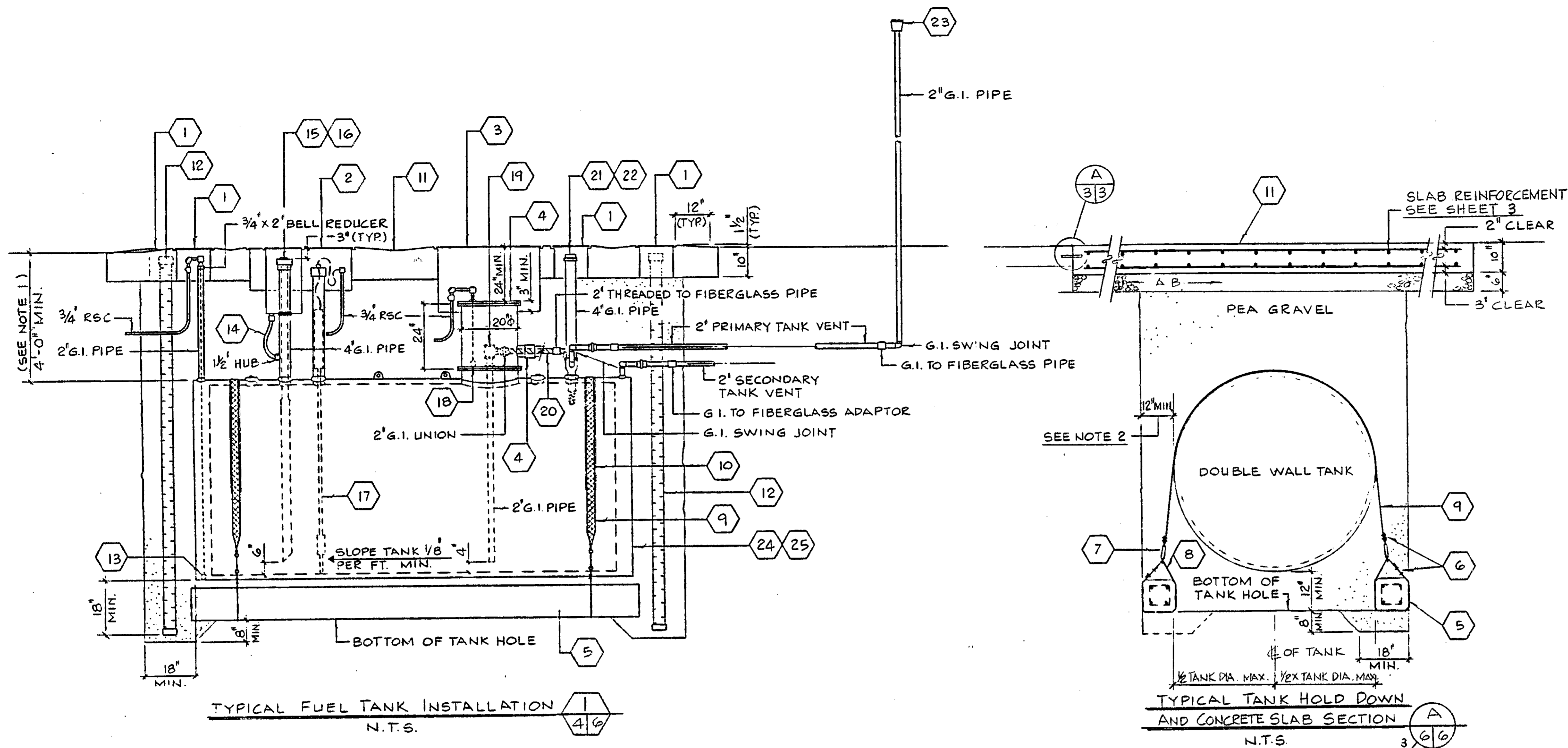

TYPICAL FUEL TANK INSTALLATION
N.T.S.

TYPICAL TANK HOLD DOWN AND CONCRETE SLAB SECTION
N.T.S.

EQUIPMENT SCHEDULE				EQUIPMENT SCHEDULE				EQUIPMENT SCHEDULE				EQUIPMENT SCHEDULE			
ITEM DESIG	DESCRIPTION	UNLEADED	DIESEL	ITEM DESIG	DESCRIPTION	UNLEADED	DIESEL	ITEM DESIG	DESCRIPTION	UNLEADED	DIESEL	ITEM DESIG	DESCRIPTION	UNLEADED	DIESEL
1	12' ROUND FILL BOX - CNI 214-S12	X	X	9	1/4" x 3" MIN. HOLD DOWN STRAP LENGTH AS REQ'D. FIBERGLASS TO ASTM A36 (TYP.) SEE NOTE 5	X	X	17	TANK LEVEL SENSOR PROBE LENGTH AS REQ'D. INSTALLATION AS PER MANUFACTURER - VEEDER ROOT	X	X	25	1,000 GALLON CAPACITY UNDER-GROUND FUEL TANK MODERN WELDING CO. INC. GLASTEEL COATED, DOUBLE WALL TANK		X
2	36" x 36" x 15" FIL-SPIL CONTAINMENT BOX W/ 20 GAL. CONTAINMENT, ONE 4" SEAL, ONE PLUG & TWO FILL COVERS W/ HEAVY DUTY LID	X	X	10	1 LAYER OF 30# FELT BETWEEN TANK AND HOLD DOWN STRAP (TYP.)	X	X	18	CONTAINMENT LEAK, INSTALLATION AS PER MANUFACTURER - UNIVERSAL LEAK ALERT SENSOR	X	X				
3	36" ROUND MANHOLE W/ REINFORCED COVER AND EXTENSION AS REQUIRED.	X	X	11	CONCRETE TANK SLAB W/ NON-SLIP BRUSH FINISH PORTLAND CEMENT, CLASS "B". SEE SHEET 3 FOR LOCATION AND SIZE OF CONCRETE SLAB	X	X	19	2" ANGLE CHECK VALVE - EMCO WHEATON A464-002	X	X				
4	20" O.D. x 24" FLANGED SPOOL W/ BOLTS, GASKETS AND COVER TO MAKE WATERTIGHT AND PROVIDE SPOOL W/ 3" HUB TO MAKE WATERTIGHT CONNECTION TO 3" FIBERGLASS PIPE TO PROVIDE CONTAINMENT OF THE 2" FUEL LINE. CONNECTION SHALL BE CONTINUOUS TO FUEL SUCTION PUMP.	X	X	12	MONITORING WELL 4" THREADED CAP, 4" THREADED ADAPTOR, 4" O.D. x LENGTH AS REQ'D PVC SLOTTED MONITOR PIPE & 4" SLIP CAP - ARLAN	X	X	20	STAINLESS STEEL TEFLON LINED, 2" O.D. x 24" LONG TELEFLEX SHALL CONNECT TO UNION AND EXTEND THROUGH 3" HUB AND CONNECT TO 2" FIBERGLASS SUCTION LINE	X	X				
5	12" SQUARE REINFORCED CONCRETE DEADMAN 3000 PSI COMPRESSIVE STR. @ 28 DAYS 4#7 BARS LONGITUDINAL REINF #3 TIES @ 6" O.C. LENGTH OF DEADMAN SHALL NOT BE LESS THAN TANK LENGTH INSTALL TWO PER TANK SEE NOTE 5.	X	X	13	SECONDARY TANK LEAK INSPECTION - UNIVERSAL LEAK ALERT SENSOR. INSTALLATION AS PER MANUFACTURE	X	X	21	(UNLEADED) PRIMARY TANK VENT 2' x 2' x 4' x 4' FLOAT VALVE EXTRACTOR - EMCO WHEATON A79-004; 4" EXTRACTOR PIPE CAP - EMCO WHEATON A584-003 (VAPOR RETURN LINE NOT SHOWN FOR CLARITY)	X					
6	DOUBLE CLAMPE STAINLESS STEEL INSTALL AS REQ'D	X	X	14	CONTAINMENT BOX DRAIN FLEXIBLE CONNECTOR 1/2" O.D. LENGTH AS REQ'D STAINLESS STEEL TEFLON LINED - TELEFLEX	X	X	22	(DIESEL) PRIMARY TANK VENT; 2' x 4' x 4' VENT - EMCO WHEATON A4103-004; 4" EXTRACTOR PIPE CAP - EMCO WHEATON A584-004		X				
7	3/4" TURNBUCKLE STAINLESS STEEL INSTALL AS REQ'D	X	X	15	(UNLEADED) TANK FILL; 4" LOCKING CAP - ANDREWS 400-FPC-AL; 4" COAXIAL DROP TUBE WITH ADAPTOR - EMCO WHEATON A88-005	X		23	2" UPWARD "V" VENT - EMCO WHEATON A4103-004	X	X				
8	1/2" O.D. WIRE ROPE STAINLESS STEEL LENGTH INSTALL AS REQ'D	X	X	16	(DIESEL) TANK FILL; 4" LOCKING CAP - ANDREWS 400-FPC-AL; 4" x 4" FILL PIPE ADAPTOR - ANDREWS 400-54-AG; 4" DROP TUBE - EMCO WHEATON A20-004		X	24	10,000 GALLON CAPACITY UNDER-GROUND FUEL TANK MODERN WELDING CO. INC. GLASTEEL COATED, DOUBLE WALL TANK	X					

CAUTION
THIS PLAN MAY BE REDUCED
DO NOT SCALE
0 1" 2"
ORIGINAL SCALE

<p>REFERENCES</p> <p>PLANS</p> <p>FIELD BOOKS</p> <p>"PORT OF OAKLAND DATUM" IS 3.20' BELOW MEAN SEA LEVEL</p>	<p>REVISIONS</p> <p>NO.</p> <p>REVISIONS</p> <p>DATE</p> <p>APP'D</p>	<p>REVIEWED: <i>[Signature]</i></p> <p>REVIEWED: <i>[Signature]</i></p> <p>REVIEWED: <i>[Signature]</i></p>	<p>DRAWN: <i>[Signature]</i></p> <p>DESIGNED: <i>[Signature]</i></p> <p>CHECKED: <i>[Signature]</i></p> <p>REVIEWED: <i>[Signature]</i></p>
--	---	---	---

PORT OF OAKLAND
66 JACK LONDON SQ. OAKLAND, CALIFORNIA

CHIEF ENGINEER
[Signature] C22138
APPROVED: *[Signature]* C13202
RECOMMENDED: *[Signature]* E8351

INNER HARBOR
CONSTRUCTION OF FUEL DISPENSING FACILITY AT BUILDING E-413
FUEL STORAGE TANK INSTALLATION DETAILS

DATE: JULY 10, 1986
SCALE: N.T.S.
SHEET 6 OF 6 SHEETS
FILE AA-2621