



100 Pringle Avenue, Suite 300
Walnut Creek, CA 94596
Tel: (925) 933-2900
Fax: (925) 933-4174

Transmittal

To: Karel Detterman
From: Ryan Wood
Organization/ Address: Alameda County Department of Environmental Health (ACDEH)
Date: April 7, 2017
Re: Fuel Leak Case No. RO0003171 and GeoTracker Global ID T10000007044
Submittal of Waste Oil UST Piping Removal/Replacement Report for BART Maintenance Shop, 601 East 8th Street, Oakland, CA 94606-3606

Via: *GeoTracker:* X *ACDEH FTP Site:* X *Courier:*

Message:

On behalf of the San Francisco Bay Area Rapid Transit District (BART), CDM Smith is submitting the attached Waste Oil UST Piping Removal/Replacement Report for the waste oil underground storage tank located at the BART Maintenance Shop, 601 East 8th Street, Oakland, CA 94606-3606, in response to ACDEH's request letter, dated March 7, 2017. The piping removal and replacement activities were completed at this facility in February 2015.

This Waste Oil UST Piping Removal/Replacement Report consists of the following attached documents:

- Form C – Certificate of Compliance – Signed by Tank Repair Contractor (page 2)
- Modification Permit (page 3 to 9)
- Inspection Report with Test Result Print-outs and Photos (page 10 to 15)

If you have any questions regarding this submittal, please contact me directly at 925-296-8015 or email me at woodr@cdmsmith.com.

Thank you,

Ryan Wood, P.G. (CDM Smith)

**UNIFIED PROGRAM CONSOLIDATED FORM
UNDERGROUND STORAGE TANK
CERTIFICATION OF INSTALLATION / MODIFICATION**
(One form per project)

I. FACILITY INFORMATION

FACILITY ID # (Agency Use Only)									
BUSINESS NAME (Same as Facility Name or DBA – Doing Business As) 3.									
BART - Maintenance Shop Oakland									
BUSINESS SITE ADDRESS 103.					CITY 104.				
601 E. 8 TH Street					Oakland, CA 94606				

II. INSTALLATION / MODIFICATION PROJECT DESCRIPTION

TYPE OF PROJECT (Check all that apply) 483a.		WORK AUTHORIZED UNDER PERMIT 483b.	
<input type="checkbox"/> 1. TANK INSTALLATION OR REPLACEMENT <input checked="" type="checkbox"/> 2. PIPING INSTALLATION OR REPLACEMENT <input type="checkbox"/> 3. SUMP INSTALLATION OR REPLACEMENT <input type="checkbox"/> 4. UNDER DISPENSER CONTAINMENT INSTALLATION OR REPLACEMENT <input type="checkbox"/> 5. OTHER		(Number or Date):	
DESCRIPTION OF WORK BEING CERTIFIED: 483c.			
- Replace Underground Waste Oil and Vent Piping runs - Concrete saw, break and dispose of approximately 2 cubic yards of concrete, and remove existing spill bucket. - Install fiberglass primary piping for the vent and remote fill lines; including secondary piping containment for both lines. - Furnish and install new piping sump penetrations to accommodate new piping, sealing existing. - Perform pipe and sump testing after repairs. - Install a new OPW multi-port spill containment manhole. - Backfill and compact excavated area. Resurface trenched area with rebar and 6" of concrete. - Schedule permit upgrade inspections and sign-off.			

III. CONTRACTOR INFORMATION

NAME OF CONTRACTOR WHO PERFORMED INSTALLATION / MODIFICATION 482a.	
Technology Engineering & Construction, Inc. dba TEC ACCUTITE	
CONTRACTOR LICENSE # 482b.	ICC CERTIFICATION # 482c.
762034	8308490

IV. CERTIFICATION

I certify that the information provided herein is true, accurate, and that the following conditions have been satisfied:

- The installer has met the requirements set forth in 23 CCR §2715, subdivisions (g) and (h).
- The underground storage tank, any primary piping, and any secondary containment was installed according to applicable voluntary consensus standards and any manufacturer's written installation instructions.
- All work listed in the manufacturer's installation checklist has been completed.
- The installation has been inspected and approved by the local agency, or if required by the local agency, inspected and certified by a registered professional engineer having education and experience with underground storage tank system installations.

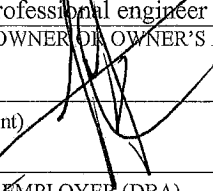
SIGNATURE OF TANK OWNER OR OWNER'S AGENT	DATE 484.	PHONE 487.
	2/25/2015	(650) 616-1200 x 229
CERTIFIER'S NAME (print) 485.	CERTIFIER'S TITLE: 486.	
Arnulfo Cardona	Project Manager	
NAME OF CERTIFIER'S EMPLOYER (DBA) 488.	CERTIFIER'S RELATIONSHIP TO TANK OWNER 489.	
TEC ACCUTITE	<input type="checkbox"/> 1. TANK OWNER <input type="checkbox"/> 2. TANK OPERATOR <input checked="" type="checkbox"/> 3. CONTRACTOR <input type="checkbox"/> 4. PROPERTY OWNER <input type="checkbox"/> 5. OTHER AUTHORIZED AGENT OF TANK OWNER	

Alameda County Department of Environmental Health

Application for Underground Storage Tank Modification

This Application For UST Modification (Or Underground Storage Tanks) Is Only Valid For
So Modified Under The Date Of Approval

Project Contact and Telephone Number ARNULFO CARDONA 650.296.1730			
Facility Name BART MAINTENANCE SHOP		Telephone Number 510-464-6654	
Address 601 E. 8 TH STREET OAKLAND, CA			
Cross Street 5 TH AVENUE.			
Underground storage tank -- Owner/Operator BAY AREA RAPID TRANSIT (BART)		Telephone Number 510-464-6654	
Contractor's Name TECHNOLOGY ENGINEERING AND CONSTRUCTION		Telephone Number 650-616-1200	
Contractor Address 262 MICHELLE COURT, SOUTH SAN FRANCISCO, CA 94080		CA License# 762034	Class C36
Hazardous Substance Certificate: Yes <u>X</u> No <u> </u> (Qualifying license category <u> </u>)		Workers Comp.# 3300067187	
Fire Department		Permit Number	
Does this site have a leaking UST (or did it have a leaking tank system?) Yes <u> </u> No <u>X</u>			
State Tank ID Number	Tank Size	Material To Be Stored	Installation Date
01-000-			
01-000-			
01-000-			
01-000			
01-000-			

APPROVED

DEPARTMENT OF ENVIRONMENTAL HEALTH

BY C. TOUGERON *ch*

DATE 3-16-2015

510-567-6804

The Applicant shall complete this checklist as applicable for the scope of work proposed. It will serve as a reminder for the applicant of the items under review for the modification of an Underground Storage Tank.

UST SYSTEM INFORMATION (Drawing and submissions must include Number 1 through Number 9)

- 1. Three complete sets of plans (include manufacturer's specification sheets for proposed equipment to be installed.
- 2. Plans drawn to scale in non-erasable print. Scale is to be at least 1/4 inch to the foot.
- 3. Plot plan to show location of tanks and all associated piping.
- 4. Detail of tank, associated piping, leak detection equipment, excavation and cover.
- 5. Tank(s) and piping approved by a nationally recognized independent Testing organization. [Title 23, Chapter 10, Article 3, Section 2631 (b), and Section 2635]
- 6. Verification of product compatibility with the tank(s). piping, monitoring device(s), epoxy or silicone glues, etc.
- 7. Manufacturer's written installation instructions for tank(s), piping, monitoring devices, etc.
- 8. na Total number of tanks on site after installation: _____
- 9. Submit a Site Safety plan. (contractor)
- 10. Contractor must submit a copy of Workers Compensation Certificate.
- 11. County/City Building Department notified.
- 12. County/City Fire District notified.
- 13. In the event contamination is observed, confirmed or suspected as a result of the tank system, it is your responsibility as an owner or operator to comply with Title 23, California Code of Regulations, Chapter 16, Article 5 (Release Reporting and Initial Abatement Requirements and Article 11 (Corrective Action Requirements).

The owner or operator must acknowledge this responsibility for work plan submittal by signature and date below:

Name ARNOLFO CARDONA
Title PROJECT MANAGER Date 02/25/15



State Of California

CONTRACTORS STATE LICENSE BOARD
ACTIVE LICENSE



License Number **762034**

Entity **CORP**

Business Name **TECHNOLOGY ENGINEERING &
CONSTRUCTION INC DBA
ACCUTITE**

Classification(s) **A HAZ B C36 C61/D40**

Expiration Date **04/30/2015**

www.cslb.ca.gov



STATE OF CALIFORNIA
STATE AND CONSUMER SERVICES AGENCY CONTRACTORS STATE LICENSE BOARD



Building Quality



**HAZARDOUS SUBSTANCES REMOVAL AND REMEDIAL
ACTIONS CERTIFICATION**

Pursuant to the provisions of Section 7058.7 of the Business and Professions Code, the Registrar of Contractors does hereby certify that the following qualifying person has successfully completed the hazardous substances removal and remedial actions examination.



Qualifier:
EDDY ARMAND TABET
License No.:
762034
Business Name:

WITNESS my hand and official seal this
24 day of AUGUST 1999
Registrar of Contractors

TECHNOLOGY ENGINEERING & CONSTRUCTION INC
ACCUTITE

13L-36 (12/97)

This certification is the property of the Registrar of Contractors and shall be returned to the Registrar upon demand when suspended, revoked or invalidated for any reason.

762034



Technology, Engineering, & Construction, Inc.
262 Michelle Court, South San Francisco, CA 94080
Tel.: 650-616-1200 Fax: 650-616-1244

December 05, 2014

SCOPE OF WORK
Waste Oil Tank Upgrades

BART Oakland Station
601 East 8th Street, Oakland, CA 94606

- 1- Replace Underground Waste Oil and Vent Piping runs**
 - * Disconnect existing vent pipe line and remote fill piping draining waste oil residues to the main tank.
 - * Concrete saw, break and dispose of approximately 2 cubic yards of concrete.
 - * Remove existing spill bucket containment and piping manhole.
 - * Remove pea gravel and stockpile for reuse
 - * Expose and remove existing piping and properly dispose as a hazardous waste.
 - * Remove all tank top fittings from bungs in order to accommodate risers for direct fill, remote fill, vent line, automatic tank gauge and overfill sensor.
 - * Install a temporary spill bucket in order to keep the tank operational.
 - * Install fiberglass primary piping for the vent and remote fill lines; including secondary piping containment for both lines.
 - * Furnish and install new piping sump penetrations to accommodate new piping, sealing existing.
 - * Terminate primary piping using ball valves and flex connectors at the sump end.
 - * Perform pipe and sump testing after repairs.
 - * Schedule permit upgrade inspection and sign-off.

- 2- Install a New Multi-port manhole**
 - * Install a new multi-port spill containment manhole over the top of tank sump to preserve future access to the tank top and to facilitate direct fill.
 - * Backfill and compact excavated area. Resurface trenched area with rebar and 6" of concrete.

- 3- Install a New Overfill Shut-off System**
 - * Install a new audible and visual monitor connected directly to a high level sensor installed on tank top; including a solenoid valve to provide shut off the oil transfer pump.
 - * Verify system operability
 - * Provide training for the new system and installation.
 - * Provide testing report and permit sign-off.

Arnulfo Cardona
Project Manager

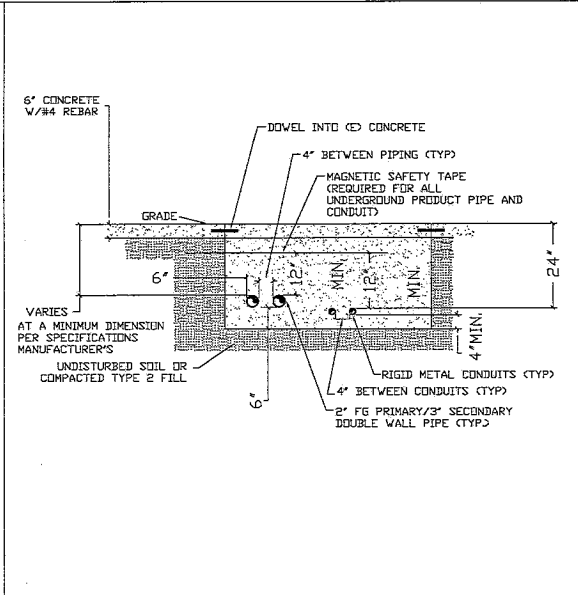
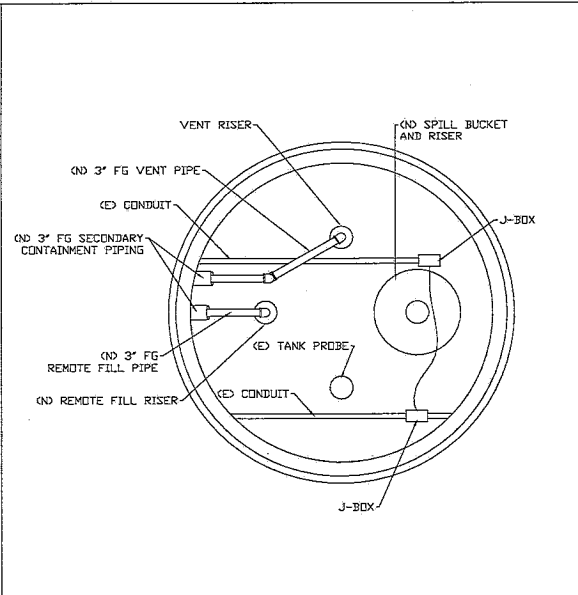
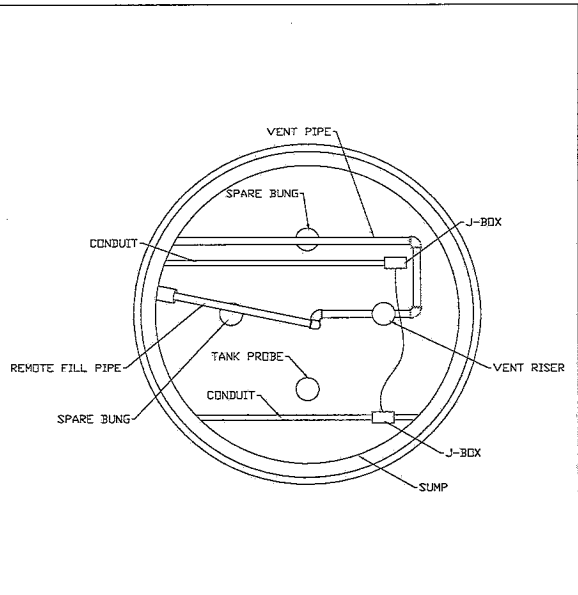

WASTE OIL UST RE-PIPING
 BART - OAKLAND MAINTENANCE YARD
 601 EAST 8TH ST.
 OAKLAND, CA 94606

Revisions		
No.	Revision/Issue	Date

EXISTING UST SUMP ARRANGEMENT

SCALE: NTS
A

PROPOSED SUMP ARRANGEMENT

SCALE: NTS
B

TYPICAL PIPE + CONDUIT TRENCH BURIAL DETAIL

SCALE: NTS
C

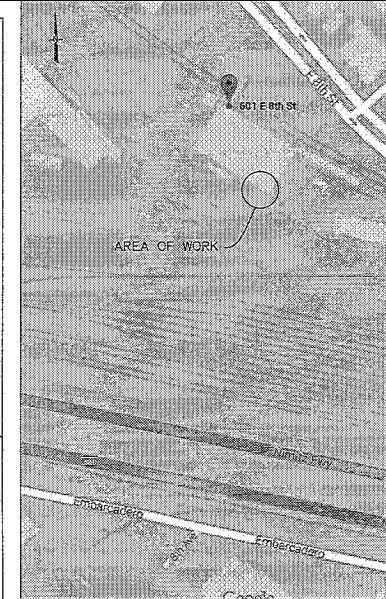
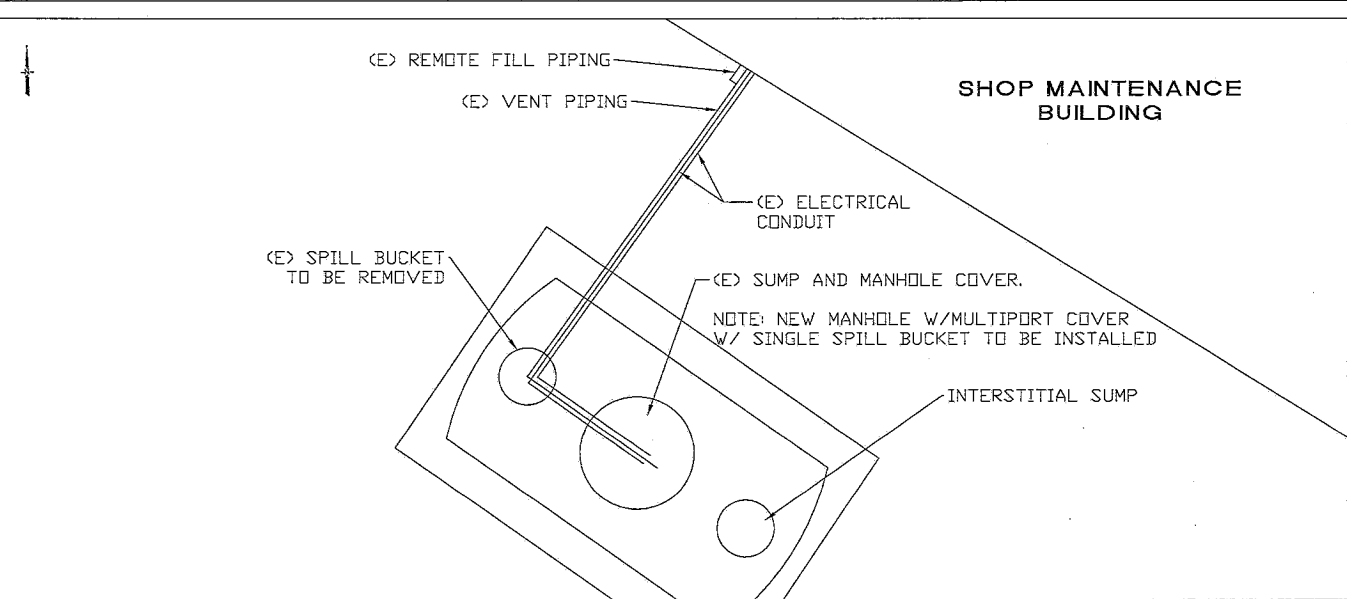

262 Michelle Court
 So. San Francisco, California 94080
 Tel: (650) 616-1200
 Fax: (650) 616-1244

Facility
 BART - OAKLAND, CA
 Project
 WASTE OIL UST RE-PIPING
 Sheet Title
 PROPOSED WORK

WASTE OIL UST PLAN LAYOUT

SCALE: NTS
1

VICINITY MAP

SCALE: NTS

Date: 9/18/2014
 Drwn By: RD
 Chckd By:
 Scale: As Noted
 Sheet



CERTIFICATE OF LIABILITY INSURANCE

DATE (MM/DD/YYYY)
7/1/2014

THIS CERTIFICATE IS ISSUED AS A MATTER OF INFORMATION ONLY AND CONFERS NO RIGHTS UPON THE CERTIFICATE HOLDER. THIS CERTIFICATE DOES NOT AFFIRMATIVELY OR NEGATIVELY AMEND, EXTEND OR ALTER THE COVERAGE AFFORDED BY THE POLICIES BELOW. THIS CERTIFICATE OF INSURANCE DOES NOT CONSTITUTE A CONTRACT BETWEEN THE ISSUING INSURER(S), AUTHORIZED REPRESENTATIVE OR PRODUCER, AND THE CERTIFICATE HOLDER.

IMPORTANT: If the certificate holder is an ADDITIONAL INSURED, the policy(ies) must be endorsed. If SUBROGATION IS WAIVED, subject to the terms and conditions of the policy, certain policies may require an endorsement. A statement on this certificate does not confer rights to the certificate holder in lieu of such endorsement(s).

PRODUCER Druml Group, Inc. 1135 Farragut Blvd Foster City CA 94404	CONTACT NAME: David Mahler
	PHONE (A/C No. Ext): (800) 949-6247 FAX (A/C No.): (650) 341-8352
	E-MAIL ADDRESS: dmahler@drumlgroup.com
	INSURER(S) AFFORDING COVERAGE NAIC #
	INSURER A: Philadelphia Indemnity 18058
	INSURER B: Cypress Insurance Company 10855
	INSURER C: Travelers Property Casualty 25674
	INSURER D:
	INSURER E:
	INSURER F:

COVERAGES CERTIFICATE NUMBER: CL147100847 REVISION NUMBER:

THIS IS TO CERTIFY THAT THE POLICIES OF INSURANCE LISTED BELOW HAVE BEEN ISSUED TO THE INSURED NAMED ABOVE FOR THE POLICY PERIOD INDICATED. NOTWITHSTANDING ANY REQUIREMENT, TERM OR CONDITION OF ANY CONTRACT OR OTHER DOCUMENT WITH RESPECT TO WHICH THIS CERTIFICATE MAY BE ISSUED OR MAY PERTAIN, THE INSURANCE AFFORDED BY THE POLICIES DESCRIBED HEREIN IS SUBJECT TO ALL THE TERMS, EXCLUSIONS AND CONDITIONS OF SUCH POLICIES. LIMITS SHOWN MAY HAVE BEEN REDUCED BY PAID CLAIMS.

INSR LTR	TYPE OF INSURANCE	ADDL INSR	SUBR VWD	POLICY NUMBER	POLICY EFF (MM/DD/YYYY)	POLICY EXP (MM/DD/YYYY)	LIMITS
	GENERAL LIABILITY						EACH OCCURRENCE \$
	<input type="checkbox"/> COMMERCIAL GENERAL LIABILITY						DAMAGE TO RENTED PREMISES (Ea occurrence) \$
	<input type="checkbox"/> CLAIMS-MADE <input type="checkbox"/> OCCUR						MED EXP (Any one person) \$
							PERSONAL & ADV INJURY \$
							GENERAL AGGREGATE \$
	GEN'L AGGREGATE LIMIT APPLIES PER:						PRODUCTS - COMP/OP AGG \$
	<input type="checkbox"/> POLICY <input type="checkbox"/> PRO-JECT <input type="checkbox"/> LOC						\$
A	AUTOMOBILE LIABILITY						COMBINED SINGLE LIMIT (Ea accident) \$ 1,000,000
	<input checked="" type="checkbox"/> ANY AUTO			PHPK1197880	7/1/2014	7/1/2015	BODILY INJURY (Per person) \$
	<input type="checkbox"/> ALL OWNED AUTOS						BODILY INJURY (Per accident) \$
	<input checked="" type="checkbox"/> HIRED AUTOS						PROPERTY DAMAGE (Per accident) \$
	<input checked="" type="checkbox"/> Comp - \$500						Terrorism \$
	<input checked="" type="checkbox"/> SCHEDULED AUTOS						
	<input checked="" type="checkbox"/> NON-OWNED AUTOS						
	<input checked="" type="checkbox"/> Coll - \$1,000						
	UMBRELLA LIAB						EACH OCCURRENCE \$
	<input type="checkbox"/> OCCUR						AGGREGATE \$
	EXCESS LIAB						\$
	<input type="checkbox"/> CLAIMS-MADE						
	DED						
	RETENTION \$						
B	WORKERS COMPENSATION AND EMPLOYERS' LIABILITY						<input checked="" type="checkbox"/> WC STATUTORY LIMITS <input type="checkbox"/> OTHER
	ANY PROPRIETOR/PARTNER/EXECUTIVE OFFICER/MEMBER EXCLUDED? (Mandatory in NH)			3300067187	7/1/2014	7/1/2015	E.L. EACH ACCIDENT \$ 1,000,000
	If yes, describe under DESCRIPTION OF OPERATIONS below						E.L. DISEASE - EA EMPLOYEE \$ 1,000,000
							E.L. DISEASE - POLICY LIMIT \$ 1,000,000
C	Equipment Floater			QT-660-7444L72A-TIL-14	7/1/2014	7/1/2015	Rented/Leased Equipment \$300,000
	Crime						Dishonesty/Forgery/Alteration \$100,000

DESCRIPTION OF OPERATIONS / LOCATIONS / VEHICLES (Attach ACORD 101, Additional Remarks Schedule, if more space is required)
[Re: PROOF OF INSURANCE]

CERTIFICATE HOLDER	CANCELLATION
Technology, Engineering and Construction, dba Accutite 262 Michelle Court South San Francisco, CA 94080	SHOULD ANY OF THE ABOVE DESCRIBED POLICIES BE CANCELLED BEFORE THE EXPIRATION DATE THEREOF, NOTICE WILL BE DELIVERED IN ACCORDANCE WITH THE POLICY PROVISIONS.
	AUTHORIZED REPRESENTATIVE
	Soy Wong/SWONG

ACORDTM CERTIFICATE OF LIABILITY INSURANCE

DATE(MM/DD/YYYY)
7/3/2014

PRODUCER ISU INS SER. - BC ENV. BROKERAGE 1037 SUNCAST LANE, SUITE 103 EL DORADO HILLS, CA 95762 (916) 939-1080		THIS CERTIFICATE IS ISSUED AS A MATTER OF INFORMATION ONLY AND CONFERS NO RIGHTS UPON THE CERTIFICATE HOLDER. THIS CERTIFICATE DOES NOT AMEND, EXTEND OR ALTER THE COVERAGE AFFORDED BY THE POLICIES BELOW.	
INSURED TECHNOLOGY ENGINEERING & CONSTRUCTION dba TEC ACCUTITE & GHG ANALYTICAL 262 MICHELLE COURT SOUTH SAN FRANCISCO, CA 94080		INSURERS AFFORDING COVERAGE INSURER A: HOMELAND INSURANCE CO OF NY INSURER B: INSURER C: INSURER D: INSURER E:	NAIC# 34452

COVERAGES

THE POLICIES OF INSURANCE LISTED BELOW HAVE BEEN ISSUED TO THE INSURED NAMED ABOVE FOR THE POLICY PERIOD INDICATED. NOTWITHSTANDING ANY REQUIREMENT, TERM OR CONDITION OF ANY CONTRACT OR OTHER DOCUMENT WITH RESPECT TO WHICH THIS CERTIFICATE MAY BE ISSUED OR MAY PERTAIN, THE INSURANCE AFFORDED BY THE POLICIES DESCRIBED HEREIN IS SUBJECT TO ALL THE TERMS, EXCLUSIONS AND CONDITIONS OF SUCH POLICIES. AGGREGATE LIMITS SHOWN MAY HAVE BEEN REDUCED BY PAID CLAIMS.

INSR LTR	ADD'L NSRD	TYPE OF INSURANCE	POLICY NUMBER	POLICY EFFECTIVE DATE(MM/DD/YY)	POLICY EXPIRATION DATE(MM/DD/YY)	LIMITS
A		GENERAL LIABILITY <input checked="" type="checkbox"/> COMMERCIAL GENERAL LIABILITY <input type="checkbox"/> CLAIMS MADE <input checked="" type="checkbox"/> OCCUR <input checked="" type="checkbox"/> CONT. POLLUTION GEN'L AGGREGATE LIMIT APPLIES PER: <input checked="" type="checkbox"/> POLICY <input type="checkbox"/> PRO-JECT <input type="checkbox"/> LOC	793-00-07-32-0002	07/01/14	07/01/15	EACH OCCURRENCE \$ 1,000,000 DAMAGE TO RENTED PREMISES (Ea occurrence) \$ 50,000 MED EXP (Any one person) \$ 5,000 PERSONAL & ADV INJURY \$ 1,000,000 GENERAL AGGREGATE \$ 2,000,000 PRODUCTS - COMP/OP AGG \$ 2,000,000
		AUTOMOBILE LIABILITY <input type="checkbox"/> ANY AUTO <input type="checkbox"/> ALL OWNED AUTOS <input type="checkbox"/> SCHEDULED AUTOS <input type="checkbox"/> HIRED AUTOS <input type="checkbox"/> NON-OWNED AUTOS				COMBINED SINGLE LIMIT (Ea accident) \$ BODILY INJURY (Per person) \$ BODILY INJURY (Per accident) \$ PROPERTY DAMAGE (Per accident) \$
		GARAGE LIABILITY <input type="checkbox"/> ANY AUTO				AUTO ONLY - EA ACCIDENT \$ OTHER THAN EA ACC \$ AUTO ONLY: AGG \$
A		EXCESS/UMBRELLA LIABILITY <input checked="" type="checkbox"/> OCCUR <input type="checkbox"/> CLAIMS MADE <input type="checkbox"/> DEDUCTIBLE RETENTION \$	793-00-07-33-0002 OVER LIAB,AUTO W/C	07/01/14	07/01/15	EACH OCCURRENCE \$ 4,000,000 AGGREGATE \$ 4,000,000
		WORKERS COMPENSATION AND EMPLOYERS' LIABILITY ANY PROPRIETOR/PARTNER/EXECUTIVE OFFICER/MEMBER EXCLUDED? If yes, describe under SPECIAL PROVISIONS below				<input type="checkbox"/> WC STATUS <input type="checkbox"/> OTHER E.L. EACH ACCIDENT \$ E.L. DISEASE - EA EMPLOYEE \$ E.L. DISEASE - POLICY LIMIT \$
A		OTHER E&O LIAB. CLAIMS MADE	793-00-07-32-0002 RETRO: 7/1/02	07/01/14	07/01/15	\$1,000,000 OCCURRENCE \$2,000,000 AGGREGATE

DESCRIPTION OF OPERATIONS/LOCATIONS/VEHICLES/EXCLUSIONS ADDED BY ENDORSEMENT/SPECIAL PROVISIONS

CERTIFICATE HOLDER

-FOR INFORMATION ONLY

CANCELLATION

SHOULD ANY OF THE ABOVE DESCRIBED POLICIES BE CANCELLED BEFORE THE EXPIRATION DATE THEREOF, THE ISSUING INSURER WILL ENDEAVOR TO MAIL 30 DAYS WRITTEN NOTICE TO THE CERTIFICATE HOLDER NAMED TO THE LEFT, BUT FAILURE TO DO SO SHALL IMPOSE NO OBLIGATION OR LIABILITY OF ANY KIND UPON THE INSURER, ITS AGENTS OR REPRESENTATIVES.

AUTHORIZED REPRESENTATIVE

Matthew C Walker

ALAMEDA COUNTY DEPARTMENT OF ENVIRONMENTAL HEALTH
Certified Unified Program Agency (CUPA)

INSPECTION REPORT SUMMARY / SUMMARY OF VIOLATIONS - NARRATIVE

Facility Name: BART

Facility Address: 601 EAST 8TH STREET, OAKLAND, CA

PERMIT WAS ISSUED BY OAKLAND FIRE DEPARTMENT TO REMOVE UNDERGROUND HAZARDOUS WASTE PIPING AND INSTALL UNDERGROUND HAZARDOUS WASTE DOUBLE WALLED FIBERGLASS PIPING. PIPING USED TO CONVEY HAZARDOUS WASTE FROM INSIDE FACILITY TO UST. HAZARDOUS WASTE USED OIL IS PNEUMATICALLY PUMPED FROM FACILITY REPAIR SHOP TEMPORARY CONTAINERS TO UST FOR ACCUMULATION.

REMOVAL OF PIPING PRIOR AND ALL WORK PERFORMED UP TO JANUARY 30, 2015 WAS OVERSEEN BY OFD. PIPING INSTALLED AND TESTING PERFORMED AFTER JANUARY 30, 2015 OVERSEEN BY ACDEH.

TEC ACCUTITE

ARNULFO CARDONA, COMPLIANCE MANAGER
262 MICHELLE COURT, SO. SAN FRANCISCO, CA 94080
650.616.1200 ACARDONA@TECACCUITITE.COM

2-11-2015 ONSITE TO WITNESS PRIMARY PIPING PRESSURE TEST DURING THE TESTING THE CONTRACTOR AND ONSITE CONSULTANT INDICATED THAT THE REMOVED UNDERGROUND PIPING WAS SINGLE WALLED THAT CONVEYED THE HAZARDOUS WASTE USED OIL TO THE UNDERGROUND STORAGE TANK. (SEE ATTACHED PHOTOS)

UNDER OFD OVERSIGHT NO SAMPLES UNDER REMOVED PIPING WERE OBTAINED. ACDEH REQUESTED TWO SAMPLES TO BE OBTAINED AT APPROXIMATE LOCATIONS UNDER PIPING JOINTS DUE TO DARK COLORED SOILS ADJACENT TO BUILDING FOOTING. SAMPLING LOCATION UNDER ONE PIPE JOINT ABOVE TANK WAS NOT TAKEN DUE TO POTENTIAL DAMAGE TO TANK.

2-13-2014 ONSITE TO WITNESS SECONDARY PIPING PRESSURE TEST AND SOIL SAMPLING. SECONDARY PIPING PASSED PRESSURE TESTING. ONE SOIL SAMPLE TAKEN/OBTAINED BY RYAN WOOD CDM SMITH CONSULTANTS NEAR THE BUILDING FOOTING (SEE PHOTO). SECOND SAMPLE COULD NOT BE OBTAINED DUE TO THE CLOSE PROXIMITY OF THE UST. ACDEH PROVIDED MR. WOOD WITH THE MINIMUM VERIFICATION ANALYSIS REQUIREMENTS (ATTACHED). SAMPLE ANALYSIS WILL BE PROVIDED TO ACDEH FOR REVIEW.

2-19-2015 ONSITE TO WITNESS SECONDARY CONTAINMENT HYDROSTATIC TEST OF THE TANK TOP SUMP. SUMP PASSED TESTING.

ACDEH RECEIVED SAMPLE RESULTS AND DETERMINED THAT RELEASE HAS OCCURRED FROM THE SINGLE WALLED PIPING THAT CONVEYED HAZARDOUS WASTE USED OIL. THIS FACILITY WILL BE FORWARDED TO ACDEH LOP GROUP FOR REVIEW.

6 MONTH POST CONSTRUCTION INSPECTION / TESTING WILL BE REQUIRED ON OR BEFORE
AUGUST 19, 2015

Date of Inspection

Inspector

Signature of Facility Representative

2-19-2015

CHRIS TOUGERON



Page ___ of ___

BART OAKLAND
681 E 8TH ST
OAKLAND

02/19/2015 8:27 AM

SUMP LEAK TEST REPORT

WOSUMP

TEST STARTED 8:12 AM
TEST STARTED 02/19/2015
BEGIN LEVEL 5.2184 IN
END TIME 8:27 AM
END DATE 02/19/2015
END LEVEL 5.2182 IN
LEAK THRESHOLD 0.002 IN
TEST RESULT PASSED

NO SB

TEST STARTED 8:12 AM
TEST STARTED 02/19/2015
BEGIN LEVEL 5.6834 IN
END TIME 8:27 AM
END DATE 02/19/2015
END LEVEL 5.6836 IN
LEAK THRESHOLD 0.002 IN
TEST RESULT PASSED

B.A.R.T. MAIN SHOP
601 E. 8TH ST.
OAKLAND CA. 94606
510-464-6652

FEB 25. 2015 12:42 PM

----- SYSTEM STATUS REPORT -----
ALL FUNCTIONS NORMAL

----- SENSOR ALARM -----
L 5:WASTE OIL SUMP
PIPING SUMP
✓ SENSOR OUT ALARM
FEB 25. 2015 12:51 PM

----- SENSOR ALARM -----
L 5:WASTE OIL SUMP
PIPING SUMP
SENSOR OUT ALARM
FEB 25. 2015 1:14 PM

B.A.R.T. MAIN SHOP
601 E. 8TH ST.
OAKLAND CA. 94606
510-464-6652

FEB 25. 2015 1:27 PM

----- SYSTEM STATUS REPORT -----
ALL FUNCTIONS NORMAL

----- IN-TANK ALARM -----
T 4:WASTE OIL
PROBE OUT
FEB 25. 2015 2:21 PM

----- SENSOR ALARM -----
L 5:WASTE OIL SUMP
PIPING SUMP
✓ FUEL ALARM
FEB 25. 2015 2:22 PM

B.A.R.T. MAIN SHOP
601 E. 8TH ST.
OAKLAND CA. 94606
510-464-6652

FEB 25. 2015 2:23 PM

----- SYSTEM STATUS REPORT -----
ALL FUNCTIONS NORMAL

B.A.R.T. MAIN SHOP
601 E. 8TH ST.
OAKLAND CA. 94606
510-464-6652

FEB 25. 2015 2:25 PM

SYSTEM STATUS REPORT

ALL FUNCTIONS NORMAL

INVENTORY REPORT

T 1:6000 UNLEADED
VOLUME = 4094 GALS
ULLAGE = 1803 GALS
90% ULLAGE= 1213 GALS
TC VOLUME = 4091 GALS
HEIGHT = 59.38 INCHES
WATER VOL = 0 GALS
WATER = 0.00 INCHES
TEMP = 66.4 DEG F

T 2:8000 UNLEADED
VOLUME = 5532 GALS
ULLAGE = 2264 GALS
90% ULLAGE= 1484 GALS
TC VOLUME = 5530 GALS
HEIGHT = 60.81 INCHES
WATER VOL = 0 GALS
WATER = 0.00 INCHES
TEMP = 64.8 DEG F

T 3:6000 DIESEL
VOLUME = 3276 GALS
ULLAGE = 2621 GALS
90% ULLAGE= 2031 GALS
TC VOLUME = 3275 GALS
HEIGHT = 49.57 INCHES
WATER VOL = 0 GALS
WATER = 0.00 INCHES
TEMP = 67.2 DEG F

T 4:WASTE OIL
VOLUME = 86 GALS
ULLAGE = 457 GALS
90% ULLAGE= 402 GALS
TC VOLUME = 85 GALS
HEIGHT = 10.25 INCHES
WATER VOL = 2 GALS
WATER = 0.99 INCHES
TEMP = 68.0 DEG F

***** END *****

ALARM HISTORY REPORT

----- IN-TANK ALARM -----

T 4:WASTE OIL

SETUP DATA WARNING
FEB 2. 2004 11:19 AM

HIGH WATER ALARM
MAR 8. 2004 10:48 AM
FEB 2. 2004 11:22 AM

OVERFILL ALARM
JUL 8. 2010 9:57 AM

LOW PRODUCT ALARM
MAY 26. 2004 8:38 AM

HIGH PRODUCT ALARM
MAY 5. 2014 8:37 AM
APR 10. 2012 8:38 AM
JUL 8. 2010 9:56 AM

INVALID FUEL LEVEL
OCT 18. 2007 10:54 AM
OCT 18. 2007 10:01 AM
OCT 17. 2007 1:55 PM

✓ PROBE OUT
FEB 25. 2015 2:21 PM
FEB 19. 2015 6:58 AM
FEB 11. 2015 9:53 AM

HIGH WATER WARNING
MAR 8. 2004 10:48 AM
FEB 2. 2004 11:30 AM

MAX PRODUCT ALARM
MAY 7. 2014 9:23 AM
JUL 8. 2010 9:57 AM
OCT 18. 2007 9:54 AM

***** END *****

ALARM HISTORY REPORT

----- SENSOR ALARM -----

L 5:WASTE OIL SUMP
PIPING SUMP
✓ FUEL ALARM
FEB 25. 2015 2:22 PM

✓ SENSOR OUT ALARM
FEB 25. 2015 1:14 PM

SENSOR OUT ALARM
FEB 25. 2015 12:51 PM

***** END *****

----- SENSOR ALARM -----
L 4:WASTE OIL ANNULAR
ANNULAR SPACE
LOW LIQUID ALARM
FEB 25. 2015 2:26 PM

ALARM HISTORY REPORT

----- SENSOR ALARM -----

→ L 4:WASTE OIL ANNULAR
ANNULAR SPACE
✓ LOW LIQUID ALARM
FEB 25. 2015 2:26 PM

✓ SENSOR OUT ALARM
FEB 20. 2015 1:15 PM

LOW LIQUID ALARM
FEB 20. 2015 1:06 PM

***** END *****

B.A.R.T. MAIN SHOP
601 E. 8TH ST.
OAKLAND CA. 94606
510-464-6652

FEB 25. 2015 2:27 PM

SYSTEM STATUS REPORT

ALL FUNCTIONS NORMAL



