

2302 VALDEZ STREET

EXCAVATION AND SHORING PERMIT (GR1500103) CITY OF OAKLAND, ALAMEDA COUNTY, CALIFORNIA

RECEIVED
By Alameda County Environmental Health 10:21 am, Dec 28, 2015

SHEET INDEX

SHEET NO.	DESCRIPTION
C1.01	TITLE SHEET
C1.02	NOTES
C2.01	EXISTING CONDITIONS
C2.02	DEMOLITION PLAN
C3.01	EXCAVATION PLAN
C4.01	CROSS SECTIONS
C5.01	EROSION CONTROL PLAN
C5.02	EROSION CONTROL NOTES AND DETAILS
SH1	SHORING GENERAL NOTES
SH2	SHORING DETAILS
SH2.1	SHORING DETAILS
SH2.2	SHORING STREET CROSS-SECTION
SH3	SHORING PLAN
SH4	SHORING ELEVATION
SH5	SHORING ELEVATION
SH6	SHORING ELEVATION
SH7	SHORING ELEVATION

ABBREVIATIONS

Δ	DELTA	INV	INVERT
AB	AGGREGATE BASE	IRR	IRRIGATION
AC	ASPHALT CONCRETE	L	LENGTH
AD	AREA DRAIN	LF	LINEAR FEET
BW	BACK OF WALK	LG	LIP OF GUTTER
BFP	BACKFLOW PREVENTER	LID	LOW IMPACT DEVELOPMENT
BLDG	BUILDING	LT	LIGHT
BOE	BOTTOM OF EXCAVATION	N	NORTH
BOF	BOTTOM OF FOOTING	OR, O.R.	OVERHEAD OFFICIAL RECORD
BOW	BOTTOM OF WALL	PERF	PERFORATED
BTM	BOTTOM	P&E	PACIFIC GAS & ELECTRIC
C&G	CURB AND GUTTER	PL	PROPERTY LINE
CB	CATCH BASIN	PR	PROPOSED
CCP	CONCRETE CYLINDER PIPE	PVC	POLYVINYL CHLORIDE
CL	CENTER LINE	R	RADIUS
CONC	CONCRETE	RCP	REINFORCED CONCRETE PIPE
CTV	CABLE TELEVISION	S	SOUTH
DCDA	DOUBLE CHECK DETECTOR ASSEMBLY	SD	SIDEWALK
DOC	DOCUMENT	SD	STORM DRAIN
DW	DOMESTIC WATER	SDCB	STORM DRAIN CATCH BASIN
DWY	DRIVEWAY	SDMH	STORM DRAIN MANHOLE
E	EAST	SS	SANITARY SEWER
EG	EXISTING GROUND	SSCO	SANITARY SEWER CLEANOUT
ELEC	ELECTRIC	SSMH	SANITARY SEWER MANHOLE
ELEV	ELEVATION	ST	STREET
EP	EDGE OF PAVEMENT	STA	STATION
ESMT	EASEMENT	TBD	TO BE DETERMINED
EX	EXISTING	TC	TOP OF CURB
FDC	FIRE DEPARTMENT CHECK	TEL	TELEPHONE
FF	FINISHED FLOOR	TOW	TOP OF WALL
FG	FINISHED GRADE	TTC	THEORETICAL TOP OF CURB
FH	FIRE HYDRANT	TWELL	TREE WELL
FL	FLOWLINE	TYP	TYPICAL
FNC	FENCE	VC	VERTICAL CURVE
FT	FEET	VERT	VERTICAL
FW	FIRE WATER	W	WEST
GFF	GARAGE FINISHED FLOOR ELEVATION	WM	WATER METER
GND	GROUND	WV	WATER VALVE
GR	GRATE	W/	WITH
HORZ	HORIZONTAL		

LEGEND

PROPOSED	EXISTING
LOT LINE	
CONTOUR LINE	
FENCE	
STORM DRAIN	
SANITARY SEWER	SS
WATER MAIN	W
GAS LINE	GAS
ELECTRICAL LINE	E
SANITARY SEWER CLEANOUT	
SANITARY SEWER MANHOLE	
STORM DRAIN CATCH BASIN	
STORM DRAIN MANHOLE	
WATER VALVE	
FIRE HYDRANT	

ENGINEER'S STATEMENT

THESE PLANS HAVE BEEN PREPARED BY ME OR UNDER MY DIRECTION IN ACCORDANCE WITH STANDARD ENGINEERING PRACTICE.

MIKE O'CONNELL, P.E.
PROJECT MANAGER
BKF ENGINEERS

11/16/15
DATE

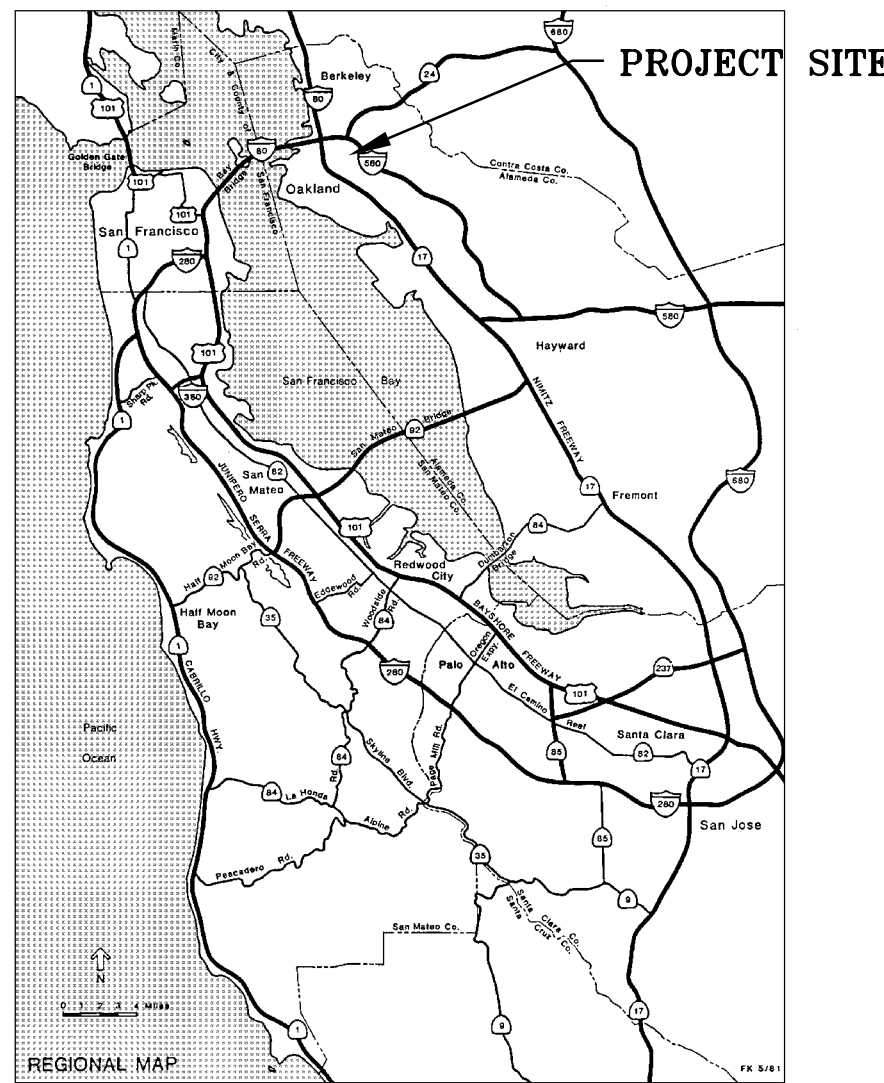

VICINITY MAP

N.T.S.



LOCATION MAP

SCALE: NTS

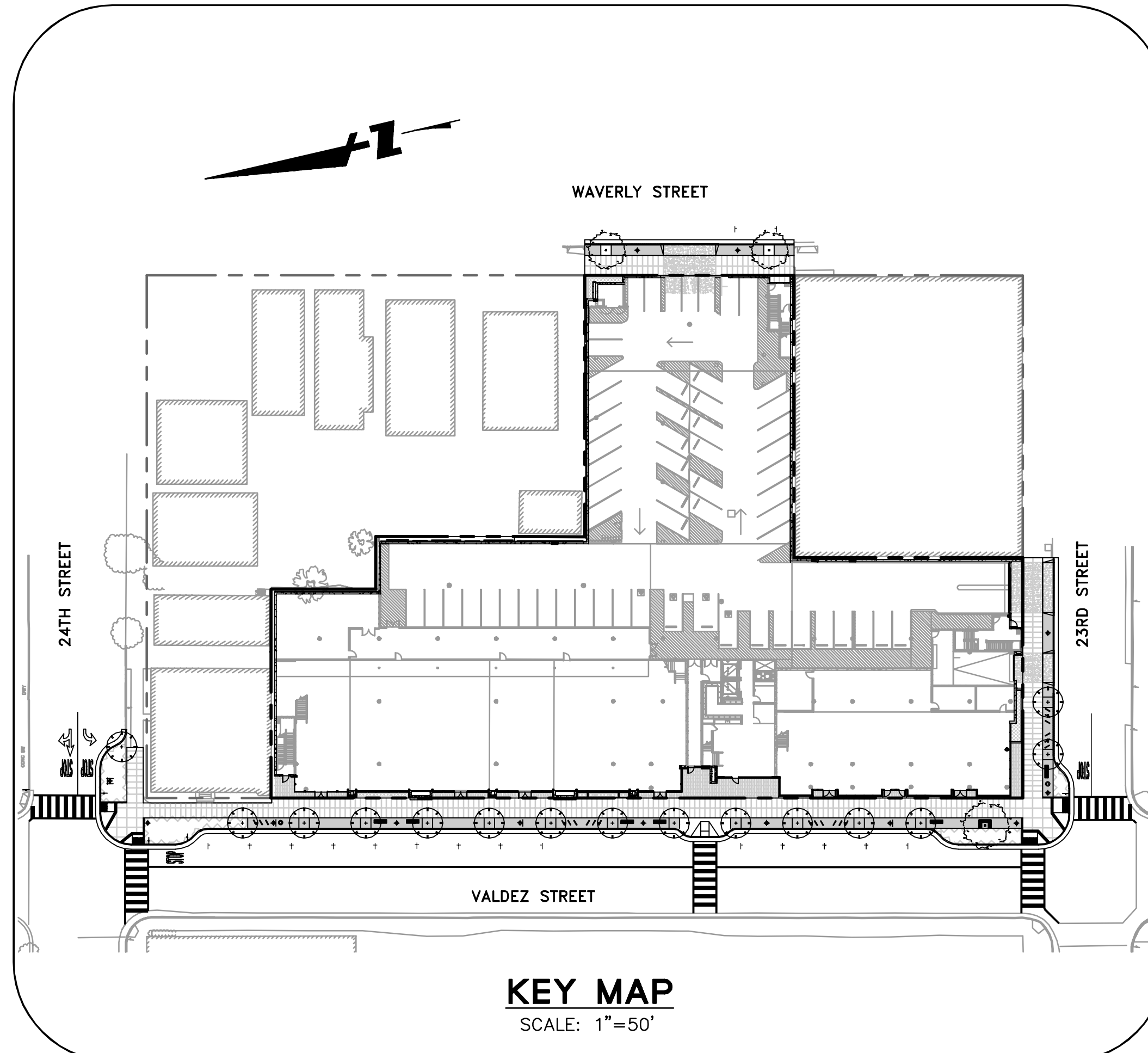

KEY MAP

SCALE: 1"=50'

APPLICANT

BRIAN PIANCA
WP WEST ACQUISITIONS, LLC
20 SUNNYSIDE DRIVE, SUITE B
MILL VALLEY, CA 94941
415.888.8537

CIVIL ENGINEER

MIKE O'CONNELL, PE
BKF ENGINEERS
150 CALIFORNIA STREET, SUITE 650
SAN FRANCISCO, CA 94111
415.930.7900

SHORING CONTRACTOR

AMERICAN DRILLING, INC.
1300 OLD BAYSHORE HIGHWAY
SAN JOSE, CA 95112
408.795.1700

BASIS OF BEARINGS

BASIS OF BEARING TAKEN AS NORTH 13°03'52" EAST AS SHOWN ON CITY OF OAKLAND MONUMENT MAP NO. 238, BETWEEN TWO FOUND CITY MONUMENTS ALONG VALDEZ STREET AT THE INTERSECTION OF 23RD AND 24TH STREET.

BENCHMARK

CITY OF OAKLAND MONUMENT AT THE INTERSECTION OF VALDEZ AND 24TH STREET, ELEVATION = 15.64 FEET, CITY OF OAKLAND DATUM

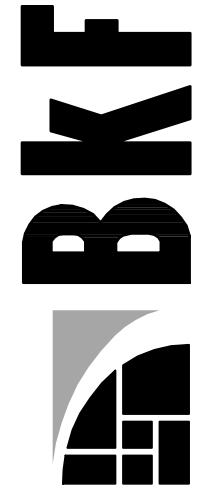

I. REFERENCE

- 2010 CALTRANS STANDARD DETAILS.
- CITY OF OAKLAND STANDARD DETAILS FOR PUBLIC WORKS CONSTRUCTION 2002 EDITION.
- STANDARD SPECIFICATIONS FOR PUBLIC WORKS CONSTRUCTION (GREEN BOOK) 2009 EDITION.

II. GENERAL NOTES

1. WORK SHALL BE PERFORMED IN ACCORDANCE WITH THE APPLICABLE SECTIONS OF THE "STANDARD SPECIFICATIONS FOR PUBLIC WORKS CONSTRUCTION (GREEN BOOK)" 2009 EDITION, THE APPLICABLE CITY OF OAKLAND STANDARD DETAILS, 2002 EDITION, AND STATE OF CALIFORNIA STANDARD SPECIFICATIONS DATED 2010, UNLESS NOTED OTHERWISE IN THE PROJECT SPECIFICATIONS OR ON THESE PLANS.
2. PROVIDE THE CITY ENGINEER TWO (2) WORKING DAYS ADVANCE NOTICE FOR INSPECTION SERVICES.
3. CONSTRUCTION STAKING SHALL BE DONE BY A CIVIL ENGINEER OR LAND SURVEYOR REGISTERED IN THE STATE OF CALIFORNIA. CONTRACTOR SHALL REQUEST STAKING SERVICES AT LEAST TWO (2) WORKING DAYS PRIOR TO THE DATE STAKING IS REQUIRED.
4. REVISIONS TO THESE PLANS MUST BE REVIEWED AND APPROVED IN WRITING BY THE CIVIL DESIGN ENGINEER PRIOR TO CONSTRUCTION OF AFFECTED ITEMS, REVISIONS SHALL BE ACCURATELY SHOWN ON REVISED PLANS.
5. STANDARD CONSTRUCTION ACTIVITIES SHALL BE LIMITED, AS PART OF THE STANDARD CONDITIONAL USE PERMIT CONDITIONS, BETWEEN 7:00 A.M. TO 7:00 P.M., MONDAY THROUGH FRIDAY. NO CONSTRUCTION ACTIVITIES SHALL BE ALLOWED ON SATURDAYS UNTIL AFTER THE BUILDING IS ENCLOSED AND WITHOUT PRIOR AUTHORIZATION OF THE BUILDING SERVICES AND PLANNING DIVISION OF THE COMMUNITY AND ECONOMIC DEVELOPMENT AGENCY, AND THEN ONLY WITH THE INTERIOR OF THE BUILDING WITH THE DOORS AND WINDOWS CLOSED. NO CONSTRUCTION ACTIVITY SHALL TAKE PLACE ON SUNDAY AND LEGAL HOLIDAYS.
6. STREET MONUMENTS AND OTHER PERMANENT MONUMENTS DISTURBED DURING THE PROCESS OF CONSTRUCTION SHALL BE RESET BY A LICENSED LAND SURVEYOR AT THE CONTRACTOR EXPENSE BEFORE ACCEPTANCE OF THE IMPROVEMENTS BY THE CITY ENGINEER.
7. PROTECT EXISTING IMPROVEMENTS TO REMAIN UNLESS SPECIFICALLY NOTED FOR DEMOLITION. RESTORE TO THEIR PREVIOUS CONDITION OR REPLACE WALLS, FENCES, SERVICES, UTILITIES, PAVEMENT, CURB, SIDEWALKS, MARKINGS AND OTHER IMPROVEMENTS TO REMAIN THAT ARE DAMAGED DUE TO THE CONTRACTOR'S WORK.
8. PREPARE A TRAFFIC CONTROL PLAN AND OBTAIN APPROVAL FROM THE CITY TRAFFIC ENGINEER BEFORE COMMENCING WORK. PROVIDE FLAGMEN, CONES OR BARRICADES, AS NECESSARY TO CONTROL TRAFFIC AND PREVENT HAZARDOUS CONDITIONS. LEAVE A 24-HOUR EMERGENCY TELEPHONE NUMBER WITH POLICE, FIRE AND PUBLIC WORKS DEPARTMENTS, AND KEEP THEM INFORMED DAILY OF DETOURS.
9. EXISTING PEDESTRIAN WALKWAYS, BIKEPATHS AND ACCESSIBLE PATHWAYS SHALL BE MAINTAINED DURING CONSTRUCTION TO THE SATISFACTION OF THE CITY ENGINEER.
10. TRENCHES SHALL NOT BE LEFT OPEN OVERNIGHT IN CITY STREET AREAS. BACKFILL TRENCHES, OR PLACE STEEL PLATING OR HOT-MIX ASPHALT AS REQUIRED TO PROTECT OPEN TRENCHES AT THE END OF EVERY WORK DAY.
11. PRIOR TO FINAL PREPARATION OF THE SUBGRADE AND PLACEMENT OF BASE MATERIALS FOR STREETS, UNDERGROUND UTILITY MAINS SHALL BE INSTALLED AND SERVICE CONNECTIONS STUBBED OUT. STUB-OUTS SHALL BE INSTALLED IN A MANNER WHICH WILL NOT DISTURB THE STREET PAVEMENT, CURB AND GUTTER, AND SIDEWALKS WHEN SERVICE CONNECTIONS ARE MADE.
12. EXCAVATIONS SHALL BE ADEQUATELY SHORED, BRACED AND SHEATHED SO THAT THE EARTH WILL NOT SLIDE OR SETTLE AND SO THAT EXISTING IMPROVEMENTS WILL BE FULLY PROTECTED FROM DAMAGE. DAMAGE RESULTING FROM A LACK OF ADEQUATE SHORING, BRACING AND SHEATHING, SHALL BE BE THE RESPONSIBILITY OF THE CONTRACTOR AND HE SHALL COMPLETE NECESSARY REPAIRS OR RECONSTRUCTION AT HIS OWN EXPENSE. WHERE THE EXCAVATION FOR A CONDUIT TRENCH, AND/OR STRUCTURE IS FIVE (5) FEET OR MORE IN DEPTH, THE CONTRACTOR SHALL PROVIDE SHEATHING, SHORING AND BRACING IN CONFORMANCE WITH THE APPLICABLE CONSTRUCTION SAFETY ORDERS OF DIVISION OF INDUSTRIAL SAFETY OF THE STATE OF CALIFORNIA. THE CONTRACTOR SHALL COMPLY WITH OSHA REQUIREMENTS.
13. PROVIDE DUST CONTROL FOR THE WORK AREA. THE AREA SHALL BE SPRINKLED AS NECESSARY TO PREVENT DUST NUISANCE.
14. DURING CONSTRUCTION, THE CITY STREETS SHALL BE CLEANED AS OFTEN AS REQUIRED TO REMOVE ACCUMULATION OF MUD AND DEBRIS RESULTING FROM CONSTRUCTION. IF IMPORT OR EXPORT OF DIRT IS NECESSARY, OBTAIN AN APPROVAL FOR THE HAULING ROUTE FROM THE CITY ENGINEERING DIVISION. THE HAULING ROUTES SHALL BE STRICTLY ADHERED TO BY THE CONTRACTOR AND SUBCONTRACTORS. DIRT HAULING PERMIT REQUIRED.
15. SHOULD IT APPEAR THAT THE WORK OUTLINE ON THESE PLANS IS NOT SUFFICIENTLY DETAILED OR SPECIFIED IN THE CONSTRUCTION DOCUMENTS, NOTIFY THE CIVIL DESIGN ENGINEER, BKF ENGINEERS AT (415)930-7900, BEFORE PROCEEDING WITH THE WORK IN QUESTION AND REQUEST CLARIFICATION.
16. WHEN SPECIFICATIONS OR STANDARDS FROM DIFFERENT AUTHORITIES DIFFER FROM THE SAME SUBJECT MATTER, NOTIFY OWNER AND REQUEST CLARIFICATION.
17. UPON SATISFACTORY COMPLETION OF THE WORK, THE WORK SITE SHALL BE CLEANED UP AND LEFT WITH A SMOOTH AND NEATLY GRADED SURFACE FREE OF CONSTRUCTION WASTE AND RUBBISH OF ANY NATURE BY THE CONTRACTOR TO THE SATISFACTION OF THE CITY ENGINEER AND OWNER.
18. CONTACT THE CITY FIRE DEPARTMENT FOR SPECIFIC REQUIREMENTS FOR BUILDINGS UNDER CONSTRUCTION.
19. COORDINATE WORK WITH THE INSTALLATION OF PG&E, AT&T, CABLE TV FACILITIES & EBMUD.
20. AN ENCROACHMENT PERMIT OR OBSTRUCTION PERMIT IS REQUIRED FOR WORK WITHIN THE PUBLIC RIGHT-OF-WAY OR EASEMENT AND MUST BE OBTAINED PRIOR TO THE START OF WORK.
21. DEWATERING ACTIVITIES SHALL COMPLY WITH THE CONDITIONS OF THE BAY AREA REGIONAL WATER QUALITY CONTROL BOARD GENERAL PERMIT FOR CONSTRUCTION SITES.

22. NOTIFY UNDERGROUND SERVICE ALERT AT 811 ATLEAST TWO (2) WORKING DAYS PRIOR TO THE START OF WORK TO VERIFY THE LOCATION OF EXISTING UNDERGROUND UTILITIES. THE UTILITIES SHOWN ON THE PLANS ARE BASED UPON RECORD INFORMATION. HOWEVER, THE CIVIL DESIGN ENGINEER ASSUMES NO RESPONSIBILITY FOR THEIR ACCURACY OR ACTUAL LOCATIONS. THE LOCATION AND PROTECTION OF ALL UTILITIES IS THE RESPONSIBILITY OF THE CONTRACTOR.
- 23.
24. ABIDE BY THE RULES AND REGULATIONS OF THE STATE OF CALIFORNIA CONSTRUCTION SAFETY ORDERS PERTAINING TO EXCAVATIONS AND TRENCHES.
25. ADJUST TO FINAL GRADE EXISTING AND/OR NEW MANHOLES, CURB INLETS, CATCH BASIN, VALVES, MONUMENT COVERS, AND OTHER CASTINGS WITHIN THE WORK AREA TO FINAL GRADE IN PAVEMENT AND LANDSCAPE AREAS, UNLESS NOTED OTHERWISE.
26. PROVIDE AND MAINTAIN EROSION CONTROL AND STORM WATER CONTROL MEASURES PER PLAN. CONTRACTOR TO REMOVE ALL EROSION CONTROL AND STORM WATER CONTROL MEASURES PRIOR TO ACCEPTANCE BY THE CITY.
27. IF ARCHAEOLOGICAL MATERIALS ARE UNCOVERED DURING DEMOLITION WORK, WORK WITHIN 100 FEET OF THESE MATERIALS SHALL BE STOPPED UNTIL A PROFESSIONAL ARCHAEOLOGIST WHO IS CERTIFIED BY THE SOCIETY OF CALIFORNIA ARCHAEOLOGY (SCA) AND/OR THE SOCIETY OF PROFESSIONAL ARCHAEOLOGY (SOPA) HAS HAD AN OPPORTUNITY TO TO EVALUATE THE SIGNIFICANCE OF THE FIND AND SUGGEST APPROPRIATE MITIGATION MEASURES, IF THEY ARE DEEMED NECESSARY.
28. POST ON SITE EMERGENCY TELEPHONE NUMBERS FOR CITY ENGINEER, AMBULANCE, POLICE, FIRE DEPARTMENTS, AND THOSE AGENCIES RESPONSIBLE FOR MAINTENANCE OF UTILITIES IN THE VICINITY OF THE JOB SITE.
29. UPON APPROVAL OF THE PLANS AND SPECIFICATIONS BY THE CITY ENGINEER ANY CHANGE TO THE IMPROVEMENT PLANS NECESSITATED DURING CONSTRUCTION WILL REQUIRE APPROVAL OF THE CITY ENGINEER THROUGH PLAN REVISION SUBMITTED BY THE ENGINEER. CONTRACTOR TO BE HELD RESPONSIBLE FOR ANY FIELD CHANGES MADE WITHOUT WRITTEN AUTHORIZATION FROM THE ENGINEER AND BY THE CITY ENGINEER.
30. ALL REVISIONS TO THIS PLAN MUST BE REVIEWED BY THE CITY ENGINEER PRIOR TO CONSTRUCTION AND TO BE ACCURATELY SHOWN ON REVISED PLANS SIGNED BY THE CITY ENGINEER PRIOR TO THE INSTALLATION OF THE IMPROVEMENTS.
31. A SUPERINTENDENT OR REPRESENTATIVE IS REQUIRED ON-SITE AT ALL TIMES DURING CONSTRUCTION.

III. LAYOUT NOTES

1. CURB RETURN RADII AND CURB DATA ARE TO FACE OF CURB UNLESS OTHERWISE NOTED.

IV. EXISTING CONDITIONS

1. EXISTING TOPOGRAPHIC INFORMATION SHOWN ON THESE PLANS IS BASED ON A FIELD SURVEY COMPLETED BY LUK AND ASSOCIATES AND SUPPLEMENTED BY ADDITIONAL FIELD TOPOGRAPHY COMPLETED BY BKF ENGINEERS. REVIEW THE PLANS AND SPECIFICATIONS AND CONDUCT FIELD INVESTIGATIONS TO VERIFY EXISTING CONDITIONS AT THE PROJECT SITE.
2. INFORMATION REGARDING EXISTING SUBSURFACE IMPROVEMENTS AND UTILITIES SHOWN ON THESE PLANS WAS TAKEN FROM RECORD DATA KNOWN TO THE DESIGN ENGINEER AND IS NOT MEANT TO BE A FULL CATALOG OF EXISTING CONDITIONS. CONDUCT FIELD INVESTIGATIONS AS REQUIRED TO VERIFY THE LOCATION AND ELEVATION OF EXISTING SUBSURFACE IMPROVEMENTS AND UTILITIES (WHETHER SHOWN ON THESE PLANS OR NOT) PRIOR TO COMMENCEMENT OF WORK. CONTRACTOR SHALL NOTIFY THE CIVIL DESIGN ENGINEER IMMEDIATELY UPON DISCOVERY OF ANY DISCREPANCIES BETWEEN EXISTING CONDITIONS IN THE FIELD AND INFORMATION SHOWN ON THESE PLANS.
3. ELEVATIONS AND LOCATIONS OF EXISTING UTILITIES SHALL BE VERIFIED BY THE CONTRACTOR PRIOR TO STARTING OF CONSTRUCTION AFFECTING SAID LINES.

V. GRADING

1. GRADING WORK SHALL BE PREPARED IN ACCORDANCE WITH THE TECHNICAL SPECIFICATIONS AND THE REQUIREMENTS AND RECOMMENDATIONS CONTAINED IN THE SOILS REPORTS PREPARED BY LANGAN TREADWELL ROLLO TITLED "GEOTECHNICAL INVESTIGATION 23RD AND VALDEZ, OAKLAND, CALIFORNIA," DATED 2 FEBRUARY 2015.

VI. PORTLAND CEMENT CONCRETE

1. UNLESS OTHERWISE NOTED, PORTLAND CEMENT CONCRETE SHALL CONFORM TO THE APPLICABLE PROVISIONS OF SECTIONS 201 AND 303 OF THE "GREEN BOOK."

VII. RECORD DRAWINGS

1. KEEP ACCURATE AS-BUILT DRAWINGS WHICH SHOW THE FINAL LOCATION, ELEVATION, AND DESCRIPTION OR WORK. NOTE THE LOCATION AND ELEVATION OF EXISTING IMPROVEMENTS ENCOUNTERED. RECORD DRAWINGS SHALL BE "REDLINED" ON A SET OF PRINTS. THE REDLINED PRINTS SHALL BE DELIVERED TO THE CONSTRUCTION MANAGER.

VIII. STATEMENT OR RESPONSIBILITY

1. CONSTRUCTION CONTRACTOR AGREES THAT IN ACCORDANCE WITH GENERALLY ACCEPTED CONSTRUCTION PRACTICES, CONSTRUCTION WILL BE REQUIRED TO ASSUME SOLE AND COMPLETE RESPONSIBILITY FOR JOB SITE CONDITIONS DURING THE COURSE OF CONSTRUCTION OF THE PROJECT, INCLUDING SAFETY OF ALL PERSONS AND PROPERTY. THIS REQUIREMENT SHALL BE MADE TO APPLY CONTINUOUSLY AND NOT BE LIMITED TO NORMAL WORKING HOURS, AND CONSTRUCTION CONTRACTOR FURTHER AGREES TO DEFEND, INDEMNIFY AND HOLD DESIGN PROFESSIONAL HARMLESS FROM ANY AND ALL LIABILITY, REAL OR ALLEGED, IN CONNECTION WITH THE PERFORMANCE OR WORK ON THIS PROJECT, EXCEPTING LIABILITY ARISING FROM THE SOLE NEGLIGENCE OF THE DESIGN PROFESSIONAL.
2. COMPLY WITH STATE, COUNTY AND CITY LAWS AND ORDINANCES; AND REGULATIONS OF THE DEPARTMENT OF INDUSTRIAL RELATIONS, OSHA AND INDUSTRIAL ACCIDENT COMMISSION RELATING TO SAFETY AND CHARACTER OF WORK, EQUIPMENT AND LABOR PERSONNEL.

IX. UNAUTHORIZED CHANGES AND USES

1. THE CIVIL DESIGN ENGINEER PREPARING THESE PLANS WILL NOT BE RESPONSIBLE FOR, OR LIABLE FOR, UNAUTHORIZED CHANGES TO OR USES OF THESE PLANS. CHANGES TO THE PLANS MUST BE IN WRITING AND MUST BE APPROVED BY THE PREPARER OF THESE PLANS.

DRAWING NAME: K:\2014\140231\ENGR\GRADING PERMIT\TY\Plotted Sheets\C1_02 - Notes.dwg
PLOT DATE: 11-12-15
PLOTTED BY: hoj



Know what's below.
Call before you dig.

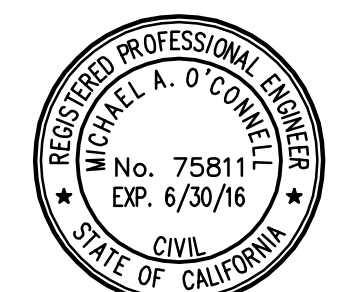

Date	11/16/15
Scale	N/A
Design	JVH
Drawn	JVH
Approved MAO	
Job No	20140231
Drawing Number:	C1.02
	2 OF 8

DRAWING NAME: K:\2014\140231\ENGR\GRADING PERMIT\Plotted Sheets\C2.01 - Existing Conditions.dwg
PLOT DATE: 11-12-15 PLOTTED BY: hoj

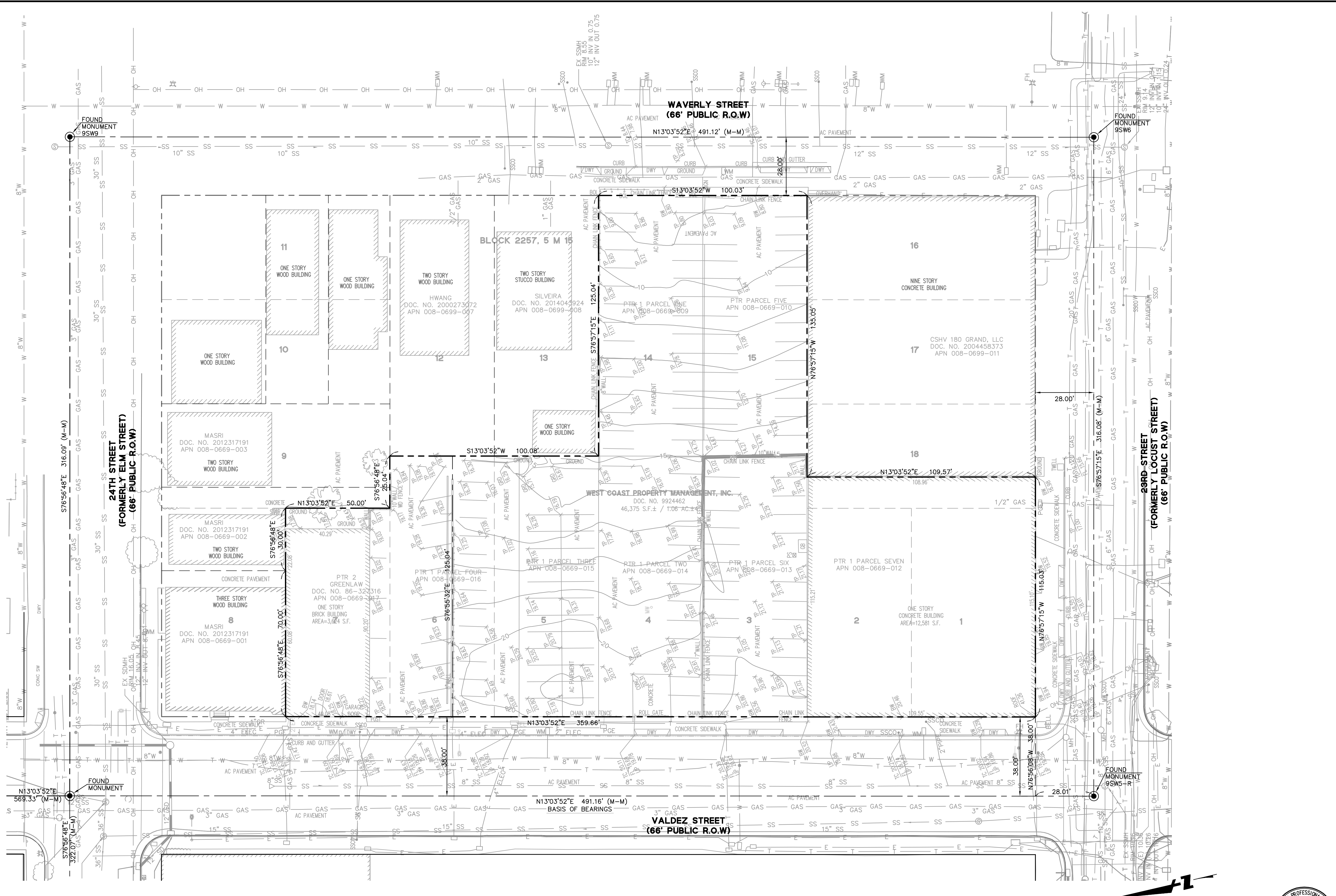

Date	11/16/15
Scale	1"=20'
Design	JVH
Drawn	JVH
Approved MAO	
Job No	20140231
Drawing Number:	C2.01
	3 OF 8

2302 VALDEZ STREET
EXCAVATION AND SHORING PERMIT (GR1500103)
EXISTING CONDITIONS
ALAMEDA COUNTY
CITY OF OAKLAND
CALIFORNIA

BKF
Engineers / Planners / Surveyors
150 CALIFORNIA STREET, STE 650
SAN FRANCISCO, CA 94111
415.930.7900
415.930.7949

DRAWING NAME: K:\2014\140231\ENGR\GRADING\PERMIT\Plotted Sheets\C2.02 - Demolition.dwg
PLOT DATE: 11-12-15
PLOTTED BY: hoj

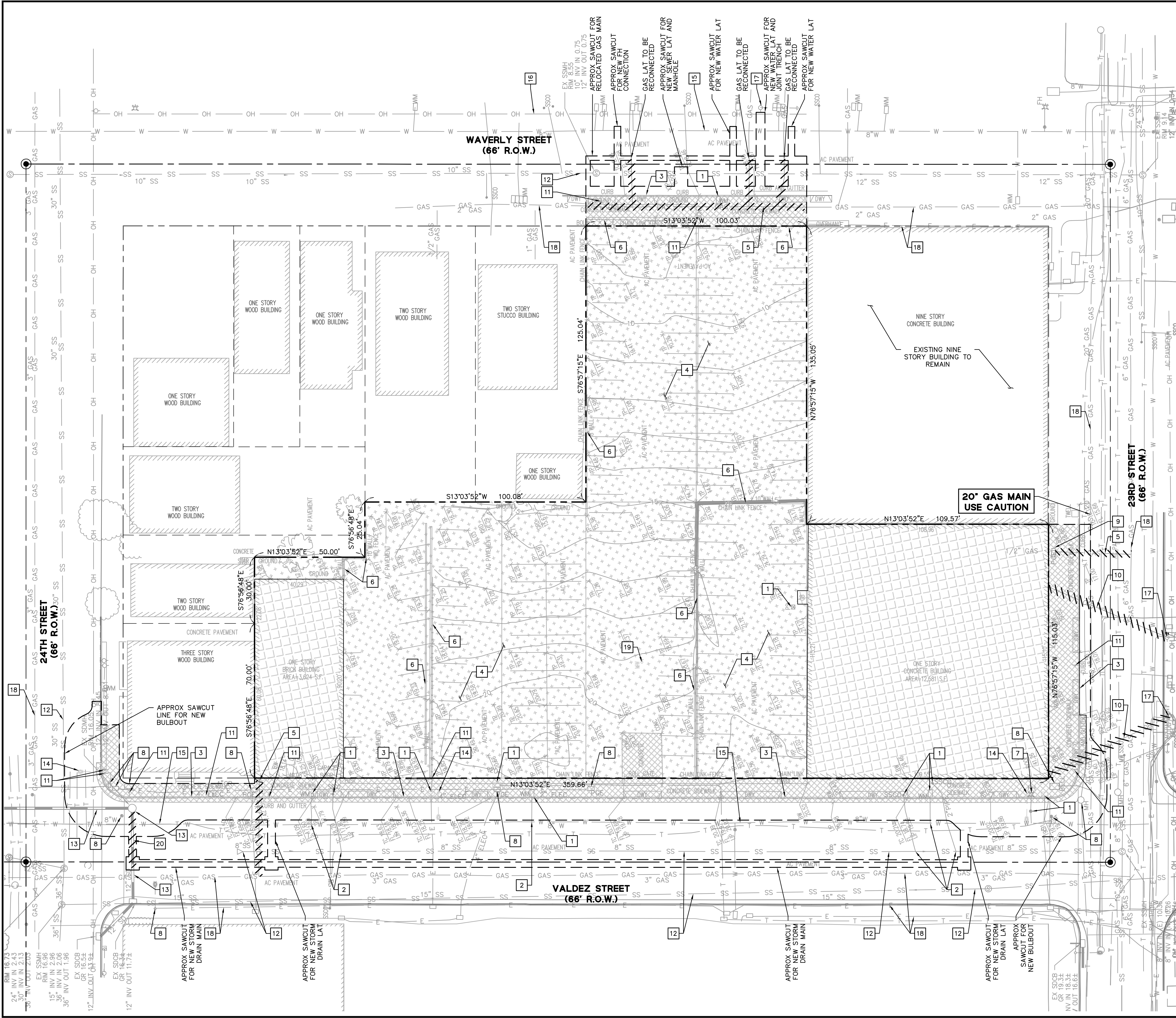

DEMOLITION NOTES:

- SEE JOINT TRENCH PLANS FOR INFORMATION ON GAS, ELECTRIC AND TELECOM UTILITY DISPOSITION.
- THE SEWER LINE, GAS LINE, AND WATER LINES SHALL BE SECURELY CAPPED AT MAIN WITH AN APPROVED FITTING.
- COORDINATE WITH PACIFIC GAS & ELECTRIC TO DISCONNECT GAS AND ELECTRIC SERVICES AND REMOVE METERS.
- COORDINATE WITH EAST BAY MUNICIPAL UTILITY DISTRICT TO DISCONNECT WATER SERVICE AND METER.
- MIXED DEBRIS OF ANY TYPE MUST BE DISPOSED OF IN CONTAINERS PROVIDED AND SERVICED BY THE CITY'S FRANCHISED HAULER, SPECIALTY SOLID WASTE & RECYCLING (UNLESS REMOVED AND TRANSPORTED BY THE CONTRACTED COMPANY PROVIDING THE DEMOLITION/ CONSTRUCTION SERVICE, UTILIZING THAT COMPANY'S OWN VEHICLES, CONTAINERS AND EQUIPMENT).

DEMOLITION LEGEND

- BUILDING AND FOUNDATION TO BE REMOVED.
- EXISTING ASPHALT AND BASEROCK TO BE REMOVED.
- EXISTING CURB, GUTTER, OR SIDEWALK TO BE REMOVED.
- EXISTING UTILITY LINE TO BE REMOVED.
- APPROXIMATE SAWCUT LINE. (APPROXIMATELY 1' OFF OF LIP OF GUTTER WHERE OCCURS)

- EXISTING UTILITY STRUCTURE TO BE REMOVED.
- ABANDON EXISTING LATERAL AND CAP AT MAIN.
- EXISTING CURB, GUTTER, OR VALLEY GUTTER TO BE REMOVED.
- EXISTING ON-SITE AC AND CONCRETE PAVING AND BASE ROCK TO BE REMOVED.
- EXISTING ELECTRICAL OR GAS LINE TO BE RELOCATED OR REMOVED. SEE JOINT TRENCH PLANS.
- EXISTING FENCE OR WALL TO BE REMOVED.
- EXISTING UTILITY TO BE RELOCATED.
- EXISTING UTILITY TO REMAIN.
- EXISTING GAS METER TO BE REMOVED, SEE JOINT TRENCH PLANS.
- EXISTING OVERHEAD LINE TO BE REMOVED. SEE JOINT TRENCH PLANS.
- EXISTING SIGN TO BE REMOVED.
- EXISTING SEWER LINE TO REMAIN.
- EXISTING STORM DRAIN LINE AND STRUCTURES TO REMAIN.
- EXISTING STREET LIGHT TO BE REMOVED.
- EXISTING WATERLINE TO REMAIN.
- EXISTING OVERHEAD LINE TO REMAIN.
- EXISTING JOINT POLE TO REMAIN.
- EXISTING ELECTRICAL OR GAS LINE TO REMAIN.
- EXISTING WELL TO BE REMOVED. SEE PLANS BY OTHERS.
- EXISTING STORM DRAIN LINE TO BE REPLACED.

**NOTE:
DEMOLITION PLAN SHOWN FOR
REFERENCE ONLY. SEE DEMOLITION
DRAWINGS FOR DEMOLITION PLAN.**

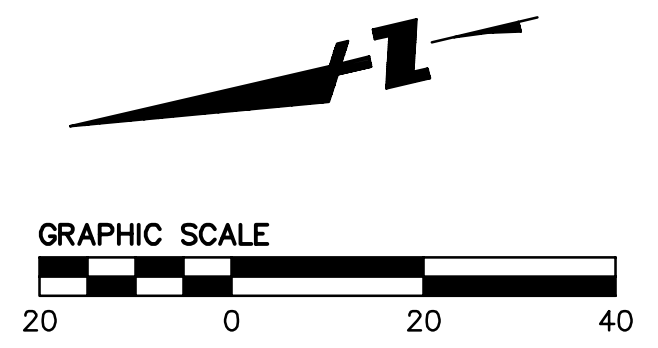

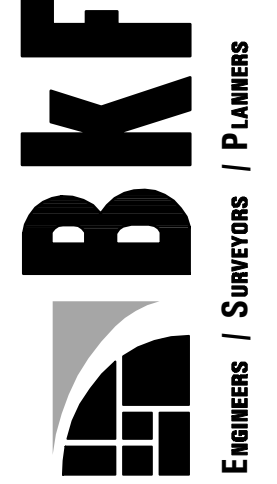

2302 VALDEZ STREET
EXCAVATION AND SHORING PERMIT (GR1500103)
EXCAVATION PLAN
ALAMEDA COUNTY
CITY OF OAKLAND

PRELIMINARY EARTHWORK QUANTITIES	
CUT	21,929 CY
FILL	0 CY
NET	21,929 CY EXPORT

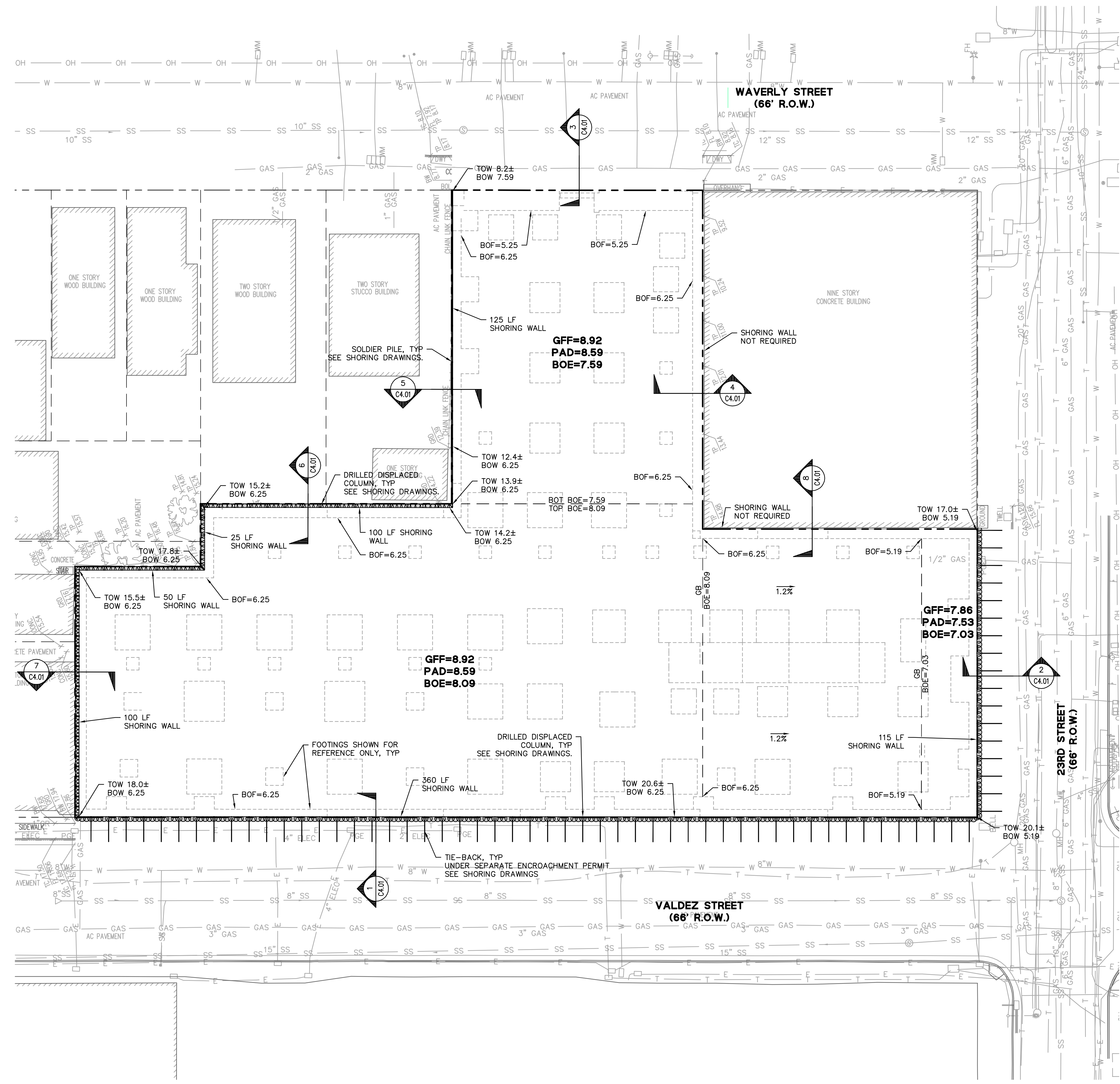

DRAWING NAME: K:\2014\140231\ENG\GRADING_PERMITS\Plotted Sheets\C3.01 - Excavation.dwg
PLOT DATE: 11-12-15
PLOTTED BY: hoj

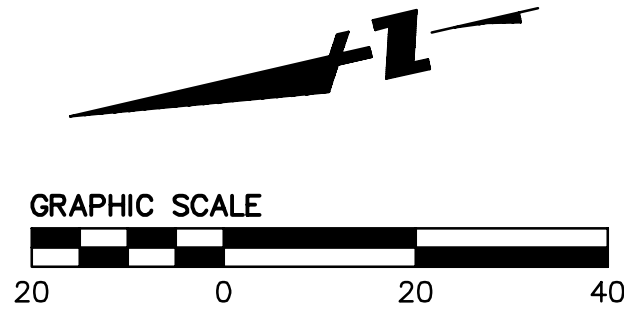

No.	Revisions

Date	11/16/15
Scale	1"=20'
Design	JVH
Drawn	JVH
Approved MAO	
Job No	20140231

Drawing Number: **C3.01**
5 OF 8

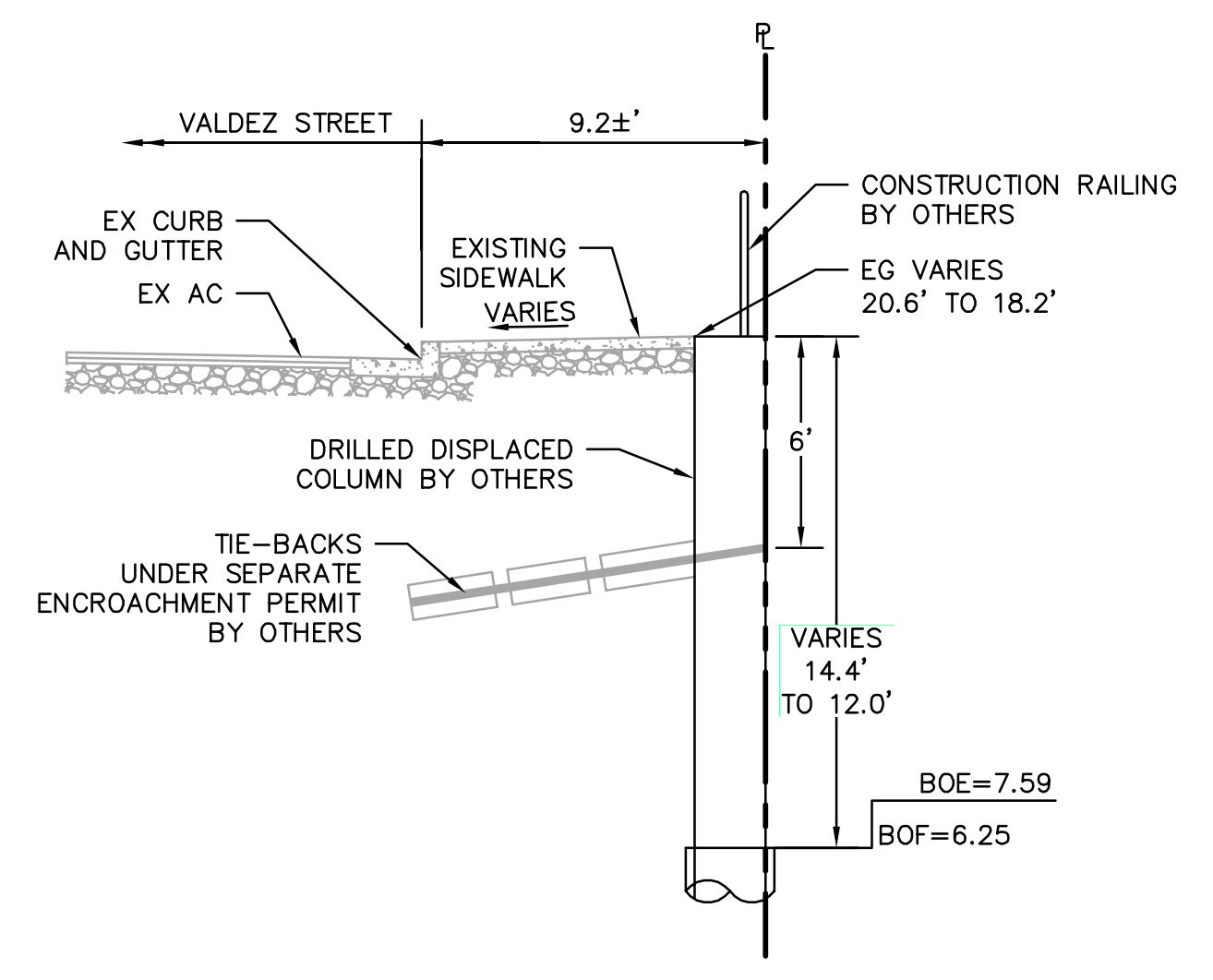

1
 SECTION AT VALDEZ STREET
 1"=5'

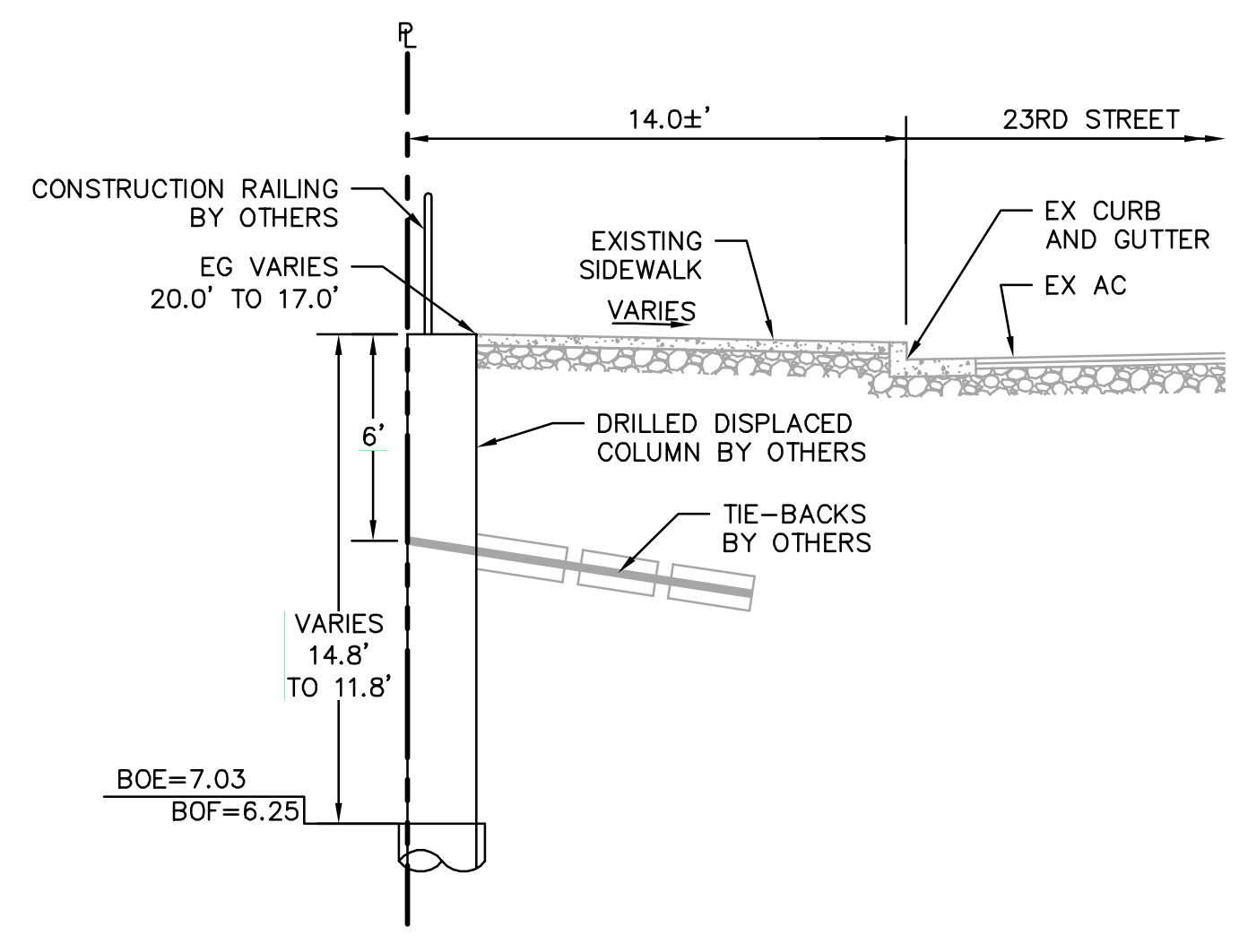

2
 SECTION AT 23RD STREET
 1"=5'

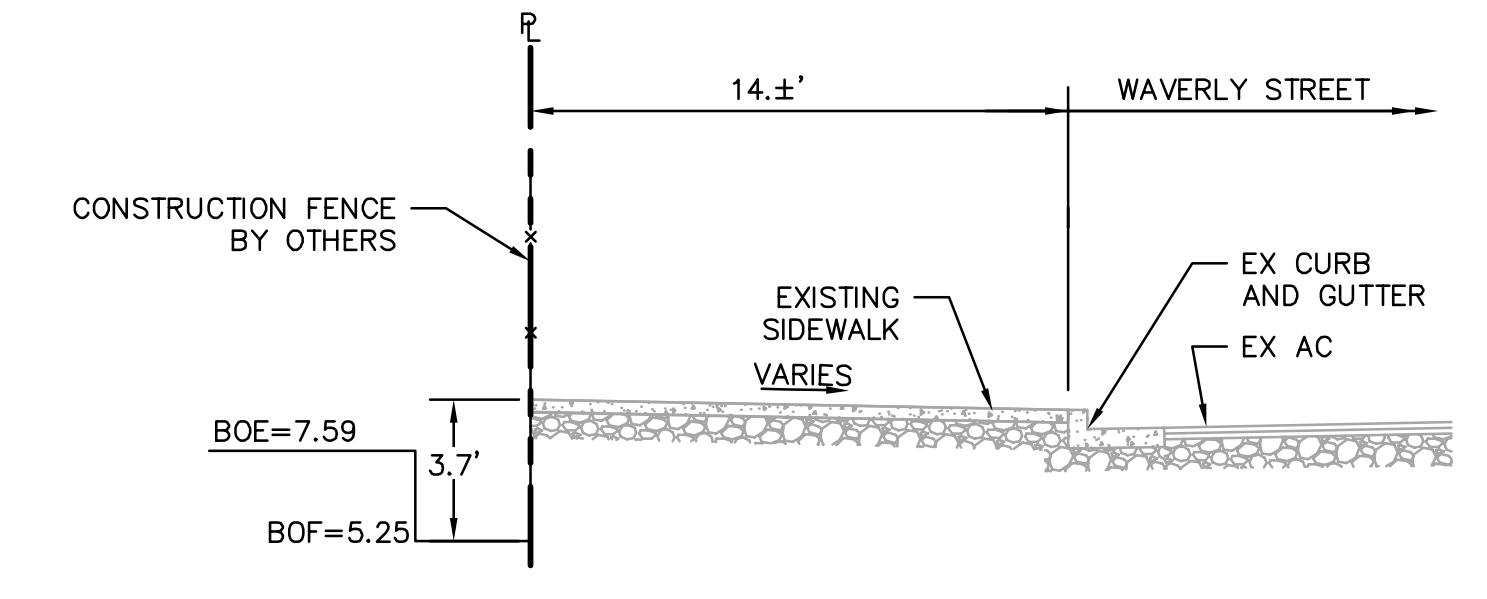

3
 SECTION AT WAVERLY STREET
 1"=5'

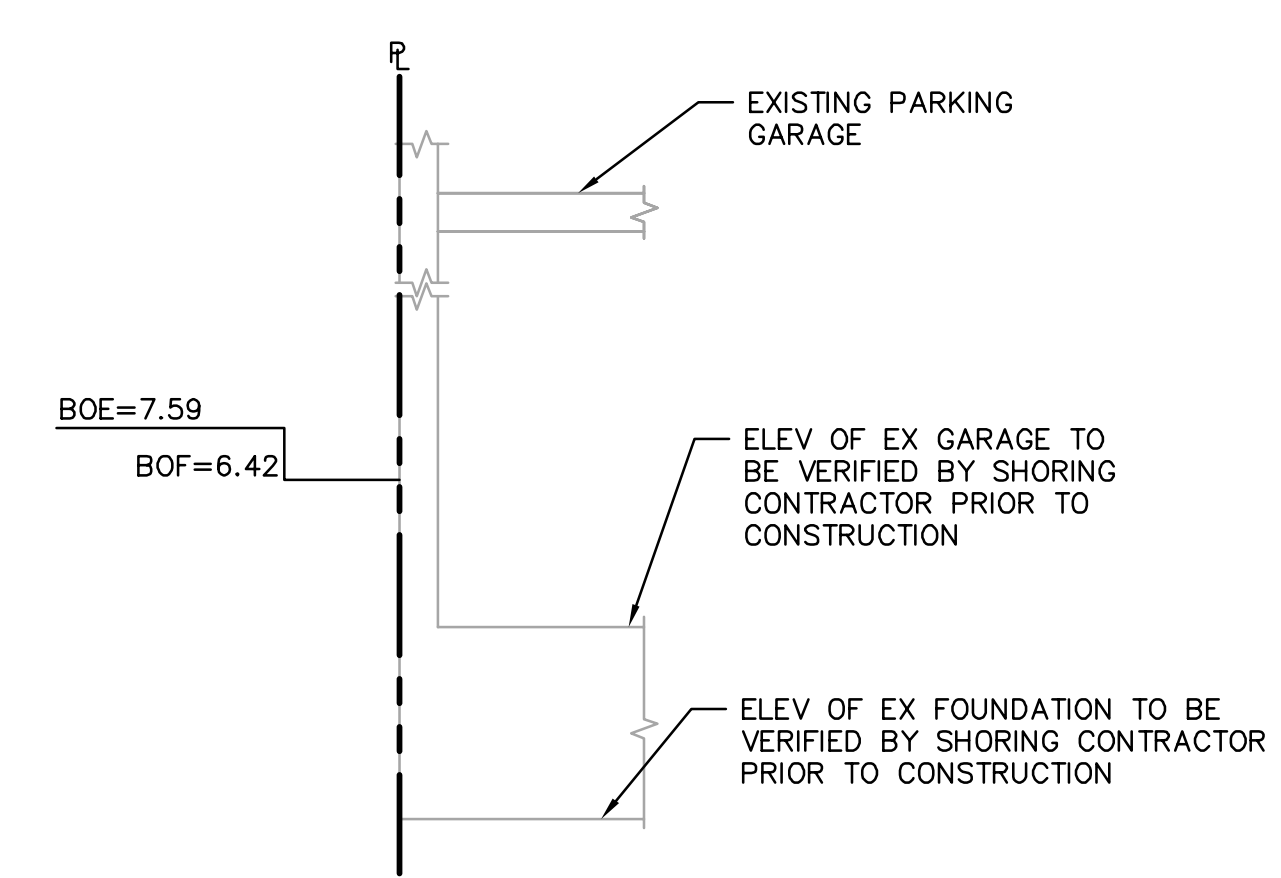

4
 SECTION AT EXISTING PARKING GARAGE
 1"=5'

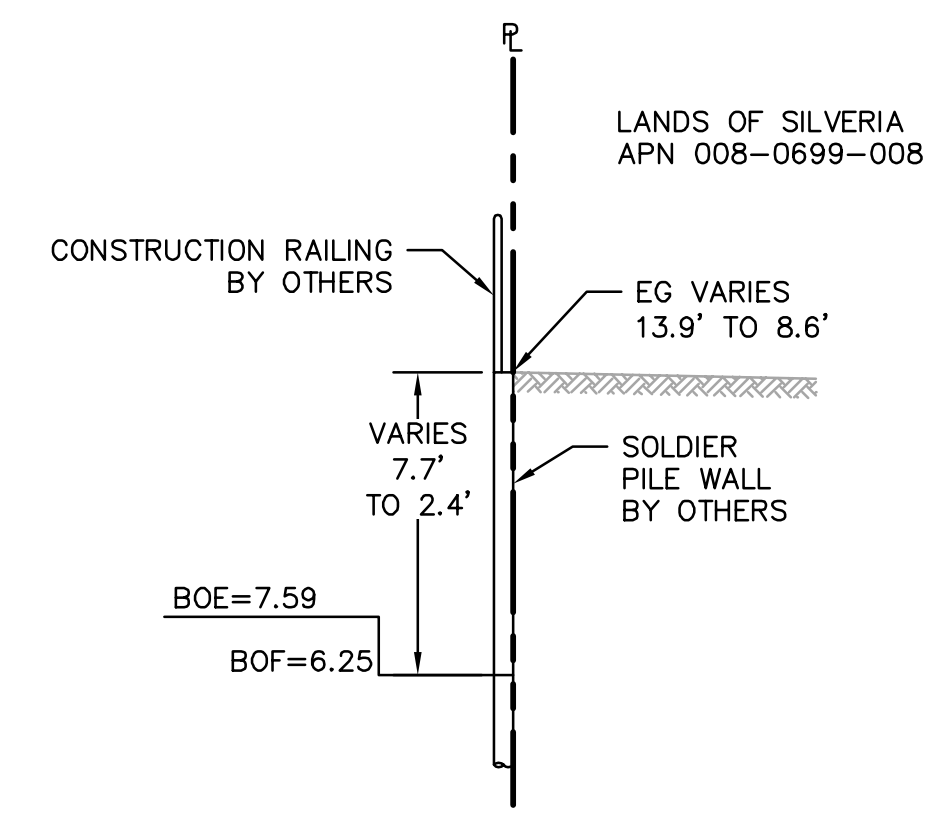

5
 SECTION AT ADJACENT PROPERTY
 1"=5'

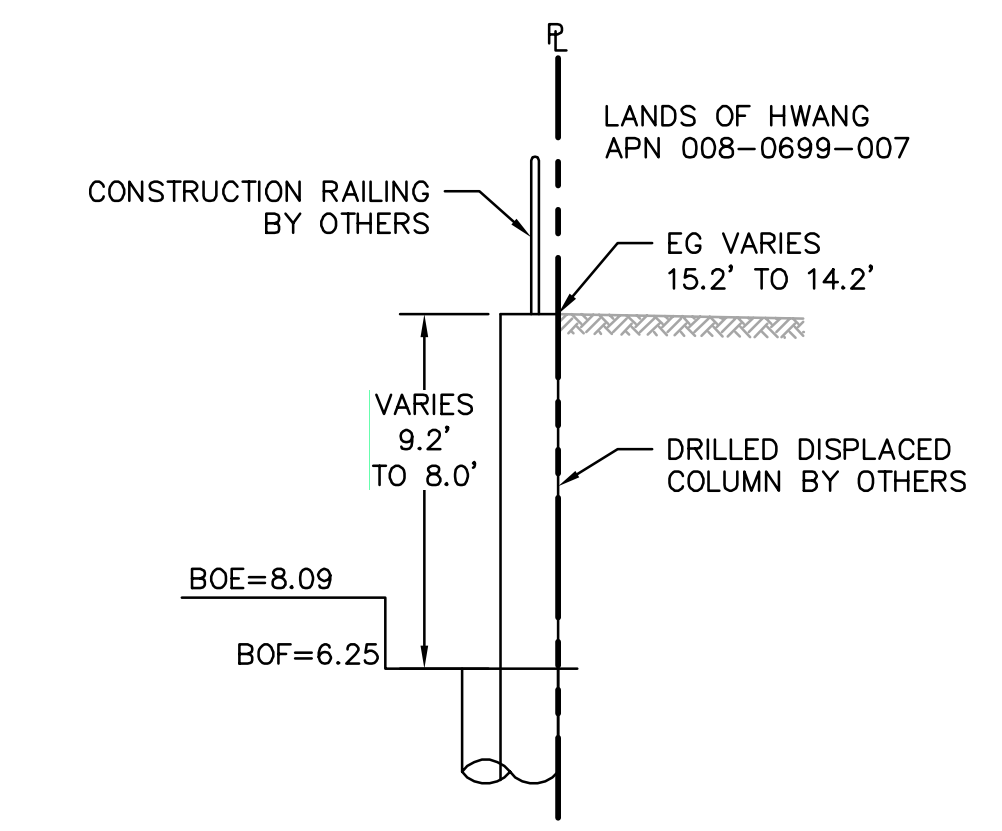

6
 SECTION AT ADJACENT PROPERTY
 1"=5'

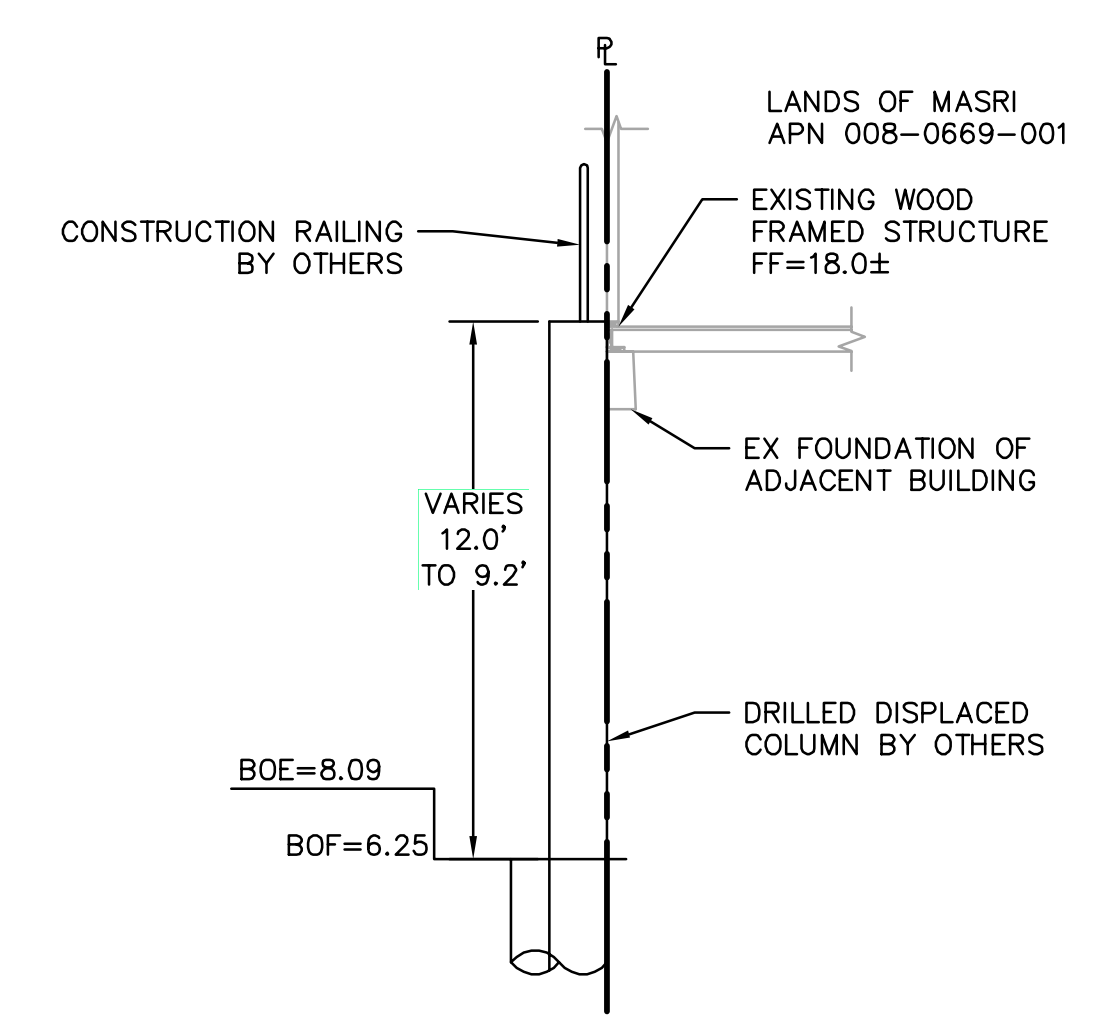

7
 SECTION AT ADJACENT PROPERTY
 1"=5'

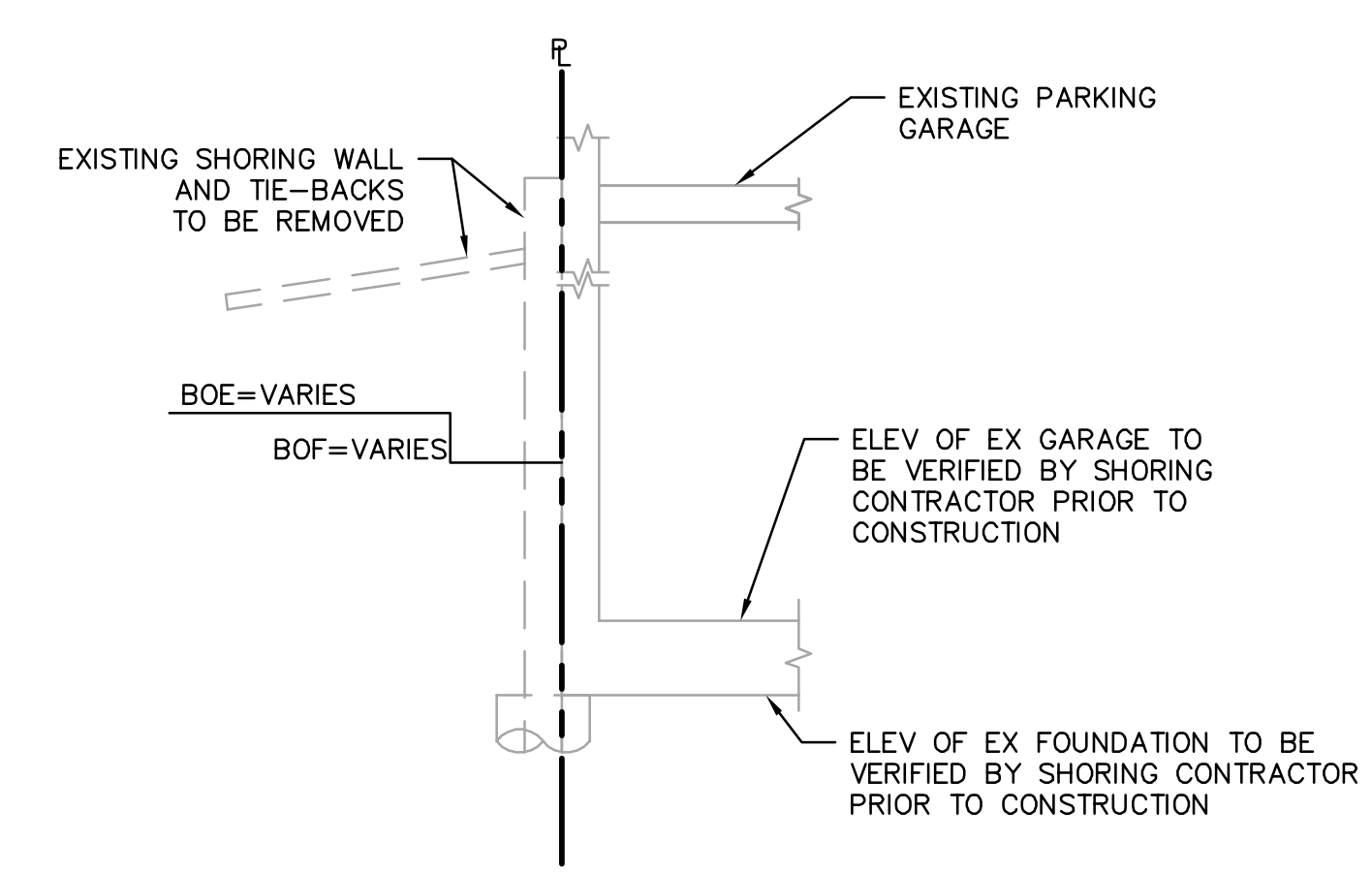

8
 SECTION AT EXISTING PARKING GARAGE
 1"=5'

DRAWING NAME: K:\2014\140231\ENG\GRADING_PERMITS\Plotted Sheets\C4.01 - Sections.dwg
 PLOT DATE: 11-12-15
 PLOTTED BY: holl



Revisions	
No.	
Date	11/16/15
Scale	1"=5'
Design	JVH
Drawn	JVH
Approved MAO	
Job No	20140231
Drawing Number:	C4.01
	6 OF 8

Revisions	
No.	Description

WAVERLY STREET
(66' R/W)

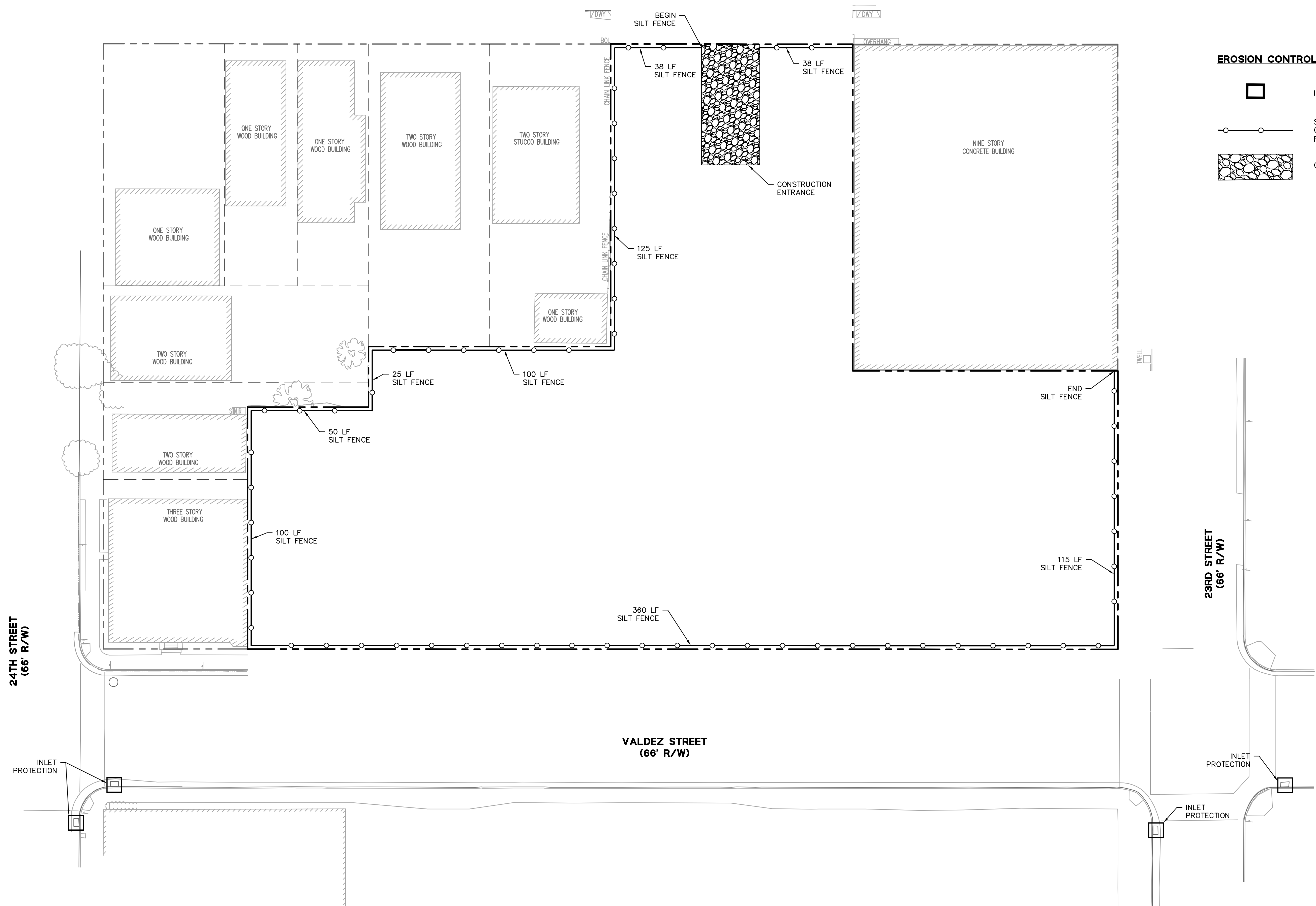

EROSION CONTROL LEGEND

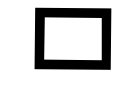
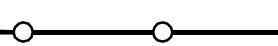
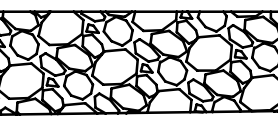
-  INLET PROTECTION 1
C5.02
-  SILT FENCE (ATTACH TO CONSTRUCTION RAILING WHERE REQUIRED) 2
C5.02
-  CONSTRUCTION ENTRANCE 3
C5.02

DRAWING NAME: K:\2014\140231\ENG\GRADING_PERMITS\Plotted Sheets\C5.01 - Erosion Control.dwg
PLOT DATE: 11-12-15
PLOTTER BY: hoj



EROSION AND SEDIMENT CONTROL NOTES:

- OWNER: WOOD PARTNERS
CONTACT: BRIAN PIANCA
20 SUNNYSIDE AVENUE, SUITE B
MILL VALLEY, CA 94941

IT SHALL BE THE OWNER'S RESPONSIBILITY TO MAINTAIN CONTROL OF THE ENTIRE CONSTRUCTION OPERATION AND TO KEEP THE ENTIRE SITE IN COMPLIANCE WITH THE SOIL EROSION CONTROL PLAN.
- CIVIL ENGINEER: BKF ENGINEERS
150 CALIFORNIA STREET, SUITE 650
SAN FRANCISCO, CA 94111
(415) 930-7900
- CONSTRUCTION SUPERINTENDENT:
CONTRACTOR: ANDERSEN CONSTRUCTION COMPANY
CONTACT: BRIAN HUGHES
ADDRESS: 6712 N. CUTTER CIRCLE
PORTLAND, OR 97217
TELEPHONE: (503) 285-6712
- THIS PLAN IS INTENDED TO BE USED FOR INTERIM EROSION AND SEDIMENT CONTROL ONLY AND IS NOT TO BE USED FOR FINAL ELEVATIONS OR PERMANENT IMPROVEMENTS.
- DEVELOPER WILL SUBMIT TO THE CITY MONTHLY (AT THE FIRST OF EACH MONTH BETWEEN OCTOBER 15TH AND APRIL 15TH) CERTIFICATIONS THAT ALL EROSION/SEDIMENT MEASURES IDENTIFIED ON THE APPROVED EROSION CONTROL PLAN ARE IN PLACE. IF MEASURES ARE NOT IN PLACE, DEVELOPER SHALL PROVIDE THE CITY WITH A WRITTEN EXPLANATION OF WHY THE MEASURE IS NOT IN PLACE AND WHAT WILL BE DONE TO REMEDY THIS SITUATION.
- OWNER/CONTRACTOR SHALL BE RESPONSIBLE FOR MONITORING EROSION AND SEDIMENT CONTROL MEASURES PRIOR, DURING AND AFTER STORM EVENTS.
- REASONABLE CARE SHALL BE TAKEN WHEN HAULING ANY EARTH, SAND, GRAVEL, STONE, DEBRIS, PAPER OR OTHER SUBSTANCE OVER A PUBLIC STREET, ALLEY, OR OTHER PUBLIC PLACE. SHOULD THE HAUL MATERIAL BLOW, SPILL, OR TRACK OVER UPON SAID PUBLIC OR ADJACENT PRIVATE PROPERTY, IMMEDIATE REMEDY SHALL OCCUR.
- SANITARY FACILITIES SHALL BE MAINTAINED ON THE SITE.
- DURING THE RAINY SEASON, PAVED AREAS SHALL BE KEPT CLEAR OF EARTH MATERIALS AND DEBRIS. THE SITE SHALL BE MAINTAINED SO AS TO MINIMIZE SEDIMENT LADEN RUNOFF TO THE STORM DRAINAGE SYSTEM, INCLUDING EXISTING DRAINAGE SWALES AND WATER COURSES.
- CONSTRUCTION OPERATIONS SHALL BE CARRIED OUT IN SUCH A MANNER THAT EROSION AND WATER POLLUTION WILL BE MINIMIZED. STATE AND LOCAL LAWS CONCERNING THE POLLUTION ABATEMENT SHALL BE COMPLIED WITH.
- CONTRACTOR SHALL PROVIDE DUST CONTROL AS REQUIRED BY THE APPROPRIATE FEDERAL, STATE, AND LOCAL AGENCY REQUIREMENTS.
- THE CONTRACTOR SHALL UPDATE THE PLANS TO REFLECT CHANGING SITE CONDITIONS. PLAN UPDATES SHALL BE BASED UPON GENERAL SURVEY DATA. EROSION CONTROL EFFECTIVENESS SHALL ALSO BE MONITORED AND THE PLANS UPGRADED AS REQUIRED TO PREVENT SIGNIFICANT QUANTITIES OF SEDIMENT FROM ENTERING THE DOWNSTREAM DRAINAGE SYSTEM.
- THIS PLAN MAY NOT COVER ALL THE SITUATIONS THAT ARISE DURING CONSTRUCTION DUE TO UNANTICIPATED FIELD CONDITIONS. IN GENERAL, THE CONTRACTOR IS RESPONSIBLE FOR KEEPING THE STORM RUN OFF FROM LEAVING THE SITE. GRAVELBAGS, SILT FENCES AND FIBER ROLLS SHALL BE USED BY THE CONTRACTOR ON AN AS NEEDED BASIS TO INHIBIT SILT FROM LEAVING THE SITE AND ENTERING THE STORM DRAIN SYSTEM. EXISTING, TEMPORARY, OR PERMANENT CATCH BASINS SHALL USE ONE OF THE SEDIMENT BARRIERS SHOWN.
- THE CONTRACTOR WILL BE RESPONSIBLE FOR DAMAGES TO PUBLICLY AND/OR PRIVATELY OWNED AND MAINTAINED ROADS CAUSED BY THE CONTRACTOR'S GRADING ACTIVITIES, AND WILL BE RESPONSIBLE FOR THE CLEANUP OF MATERIAL SPILLED ON PUBLIC ROADS ON THE HAUL ROUTE, ADJACENT PUBLIC ROADS SHALL BE CLEANED AT THE END OF EACH WORKING DAY.
- BEST MANAGEMENT PRACTICES AS DEFINED IN THE SWPPP SHALL BE OPERABLE YEAR ROUND.
- THE NAME, ADDRESS AND 24 HOUR TELEPHONE NUMBER OF THE PERSON RESPONSIBLE FOR IMPLEMENTATION OF EROSION AND SEDIMENTATION CONTROL PLAN SHALL BE PROVIDED TO THE CONSTRUCTION MANAGER AND THE CITY.
- TRUCK TIRES SHALL BE CLEANED PRIOR TO EXITING THE PROPERTY.
- STOCKPILED MATERIAL
A. EXCAVATED SOILS SHOULD NOT BE PLACED IN STREETS OR ON PAVED AREAS.
B. EXCAVATED SOILS SHOULD BE REMOVED FROM THE SITE BY THE END OF THE DAY, UNLESS STOCKPILING IS NECESSARY.

- SURROUND STOCKPILES WITH PERIMETER SILT FENCES, FIBER ROLLS, APPROPRIATELY SIZED SECONDARY CONTAINMENT, OR OTHER RUNOFF CONTROLS.
- STABILIZE INACTIVE STOCKPILES WITH SOIL STABILIZER AND/OR MULCH, OR COVER WITH A TARPULIN.
- COVER STOCKPILES OF CRUSHED AC OR PCC PAVEMENT WITH A TARPULIN OR PROVIDE CASE-SPECIFIC DESIGNED SECONDARY CONTAINMENT AND SURROUND WITH APPROPRIATE RUNOFF CONTROLS.
- USE INLET PROTECTION FOR STORM DRAIN STRUCTURES ADJACENT TO THE MATERIAL.
- THOROUGHLY SWEEP PAVED AREAS EXPOSED TO SOIL EXCAVATION PLACEMENT.
- IF NO WORK HAS PROCEEDED FOR A PERIOD OF 6-WEEKS, FINAL DRAINAGE AND EROSION CONTROL IMPROVEMENTS SHALL BE INSTALLED IN ACCORDANCE WITH AN APPROVED WINTERIZATION PLAN.
- SEDIMENT AND DEBRIS SHALL BE REMOVED FROM TEMPORARY BASINS AND DRAIN INLETS AFTER EACH STORM. SLOPES SHALL BE REPAIRED AS SOON AS POSSIBLE WHEN DAMAGED.
- PADS SHALL BE GRADED TO MINIMIZE STANDING WATER. SPECIFIC LOCATIONS REQUIRING SUPPLEMENTAL GRADING TO ACHIEVE ACCEPTABLE DRAINAGE SHALL BE DETERMINED BY THE CONSTRUCTION MANAGER.
- STUBBED OUT ENDS OF PARTIALLY COMPLETED SUBDRAINS SHALL BE WRAPPED WITH AN APPROVED FABRIC TO PREVENT SOIL AND DEBRIS FROM ENTERING THE PIPE.
- HAUL ROADS ARE CURRENTLY NOT SHOWN ON THE PLANS. EROSION CONTROL MEASURES SHALL BE TAKEN TO MINIMIZE EROSION RELATED TO HAUL ROADS.
- DISPOSAL AREAS FOR SEDIMENT TO BE DETERMINED IN FIELD. WHEN MATERIAL IS STOCKPILED, IT SHALL BE SURROUNDED BY FIBER ROLLS.
- TEMPORARY AND PERMANENT SLOPES GREATER THAN 5 FEET SHALL BE SEEDED UNLESS OTHERWISE SHOWN ON THE PLAN.
- ADDITIONAL EROSION CONTROL MEASURES MAY BE REQUIRED DURING GRADING OPERATION, BEFORE OCTOBER 1 AND PRIOR TO INSTALLATION OF STORM DRAINAGE SYSTEM. SUCH ADDITIONAL MEASURES WILL BE CONTINGENT UPON THE STAGE OF GRADING OPERATION. CONTRACTOR SHALL IMPLEMENT ANY ADDITIONAL EROSION CONTROL MEASURES AS REQUIRED BY THE ENGINEER.

EROSION AND SEDIMENT CONTROL MEASURES

- THE FACILITIES SHOWN ON THIS PLAN ARE DESIGNED TO CONTROL EROSION AND SEDIMENT DURING THE RAINY SEASON, OCTOBER 15 TO APRIL 15. FACILITIES ARE TO BE OPERABLE PRIOR TO OCTOBER 1 OF ANY YEAR. GRADING OPERATIONS DURING THE RAINY SEASON WHICH LEAVE DENUDE SLOPES SHALL BE PROTECTED WITH EROSION CONTROL MEASURES IMMEDIATELY FOLLOWING GRADING ON THE SLOPES.
- THIS PLAN COVERS ONLY THE FIRST WINTER FOLLOWING GRADING WITH ASSUMED SITE CONDITIONS AS SHOWN ON THE EROSION CONTROL PLAN. PRIOR TO SEPTEMBER 15, THE COMPLETION OF SITE IMPROVEMENT SHALL BE EVALUATED AND REVISIONS MADE TO THIS PLAN AS NECESSARY WITH THE APPROVAL OF THE CITY ENGINEER. PLANS ARE TO BE RESUBMITTED FOR CITY APPROVAL PRIOR TO SEPTEMBER 1 OF EACH SUBSEQUENT YEAR UNTIL SITE IMPROVEMENTS ARE ACCEPTED BY THE CITY.
- CONSTRUCTION ENTRANCES SHALL BE INSTALLED PRIOR TO COMMENCEMENT OF GRADING. CONSTRUCTION TRAFFIC ENTERING ONTO THE PAVED ROADS MUST CROSS THE STABILIZED CONSTRUCTION ENTRANCEWAYS.
- CONTRACTOR SHALL MAINTAIN STABILIZED ENTRANCE AT EACH VEHICLE ACCESS TO EXISTING PAVED STREETS. MUD OR DEBRIS TRACKED ONTO PUBLIC STREETS SHALL BE REMOVED DAILY AND AS REQUIRED BY THE CITY.
- IF HYDROSEEDING IS NOT USED OR IS NOT EFFECTIVE BY 10/10, THEN OTHER IMMEDIATE METHODS SHALL BE IMPLEMENTED, SUCH AS EROSION CONTROL BLANKETS, OR A THREE-STEP APPLICATION OF 1) SEED, MULCH, FERTILIZER 2) BLOWN STRAW 3) TACKIFIER AND MULCH.
- INLET PROTECTION SHALL BE INSTALLED AT OPEN INLETS TO PREVENT SEDIMENT FROM ENTERING THE STORM DRAIN SYSTEM. INLETS NOT USED IN CONJUNCTION WITH EROSION CONTROL ARE TO BE BLOCKED TO PREVENT ENTRY OF SEDIMENT.

MAINTENANCE NOTES

- MAINTENANCE IS TO BE PERFORMED AS FOLLOWS:
A. REPAIR DAMAGES CAUSED BY SOIL EROSION OR CONSTRUCTION AT THE END OF EACH WORKING DAY.
B. SWALES SHALL BE INSPECTED PERIODICALLY AND MAINTAINED AS NEEDED.
C. SEDIMENT TRAPS, BERMS, AND SWALES ARE TO BE INSPECTED AFTER EACH STORM AND REPAIRS MADE AS NEEDED.
D. SEDIMENT SHALL BE REMOVED AND SEDIMENT TRAP RESTORED TO ITS ORIGINAL DIMENSIONS WHEN SEDIMENT HAS ACCUMULATED TO A DEPTH OF 1 FOOT.
E. SEDIMENT REMOVED FROM TRAP SHALL BE DEPOSITED IN A SUITABLE AREA AND IN SUCH A MANNER THAT IT WILL NOT ERODE.
F. RILLS AND GULLIES MUST BE REPAIRED.
- GRAVELBAG INLET PROTECTION SHALL BE CLEANED OUT WHENEVER SEDIMENT DEPTH IS ONE HALF THE HEIGHT OF ONE GRAVELBAG.

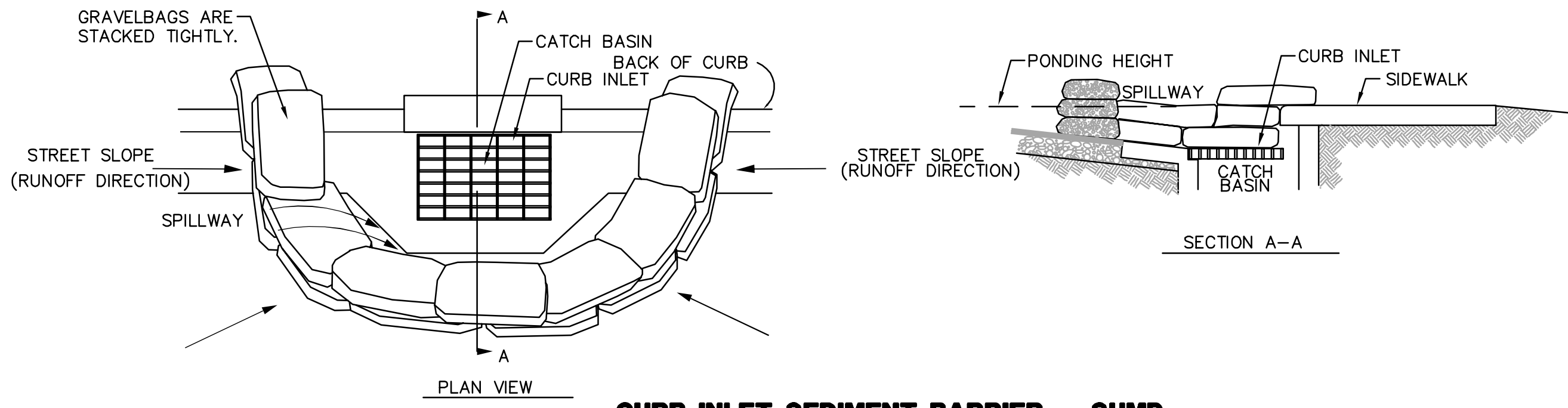

CURB INLET SEDIMENT BARRIER - SUMP

CURB INLET SEDIMENT BARRIER NOTES:

- PLACE CURB TYPE SEDIMENT BARRIERS ON GENTLY SLOPING STREETS, WHERE WATER CAN POND AND ALLOW SEDIMENT TO SEPARATE FROM RUNOFF.
- BAGS OF EITHER BURLAP OR WOVEN GEOTEXTILE FABRIC ARE FILLED WITH GRAVEL, LAYERED AND PACKED TIGHTLY.
- LEAVE ONE GRAVELBAG GAP IN THE TOP ROW TO PROVIDE A SPILLWAY OVERFLOW. TOP OF SPILLWAY SHALL BE LOWER THAN TOP OF CURB.
- INSPECT BARRIERS AND REMOVE SEDIMENT AFTER EACH STORM EVENT, SEDIMENT AND GRAVEL MUST BE REMOVED FROM THE TRAVELED WAY IMMEDIATELY.

1
INLET PROTECTION
NTS

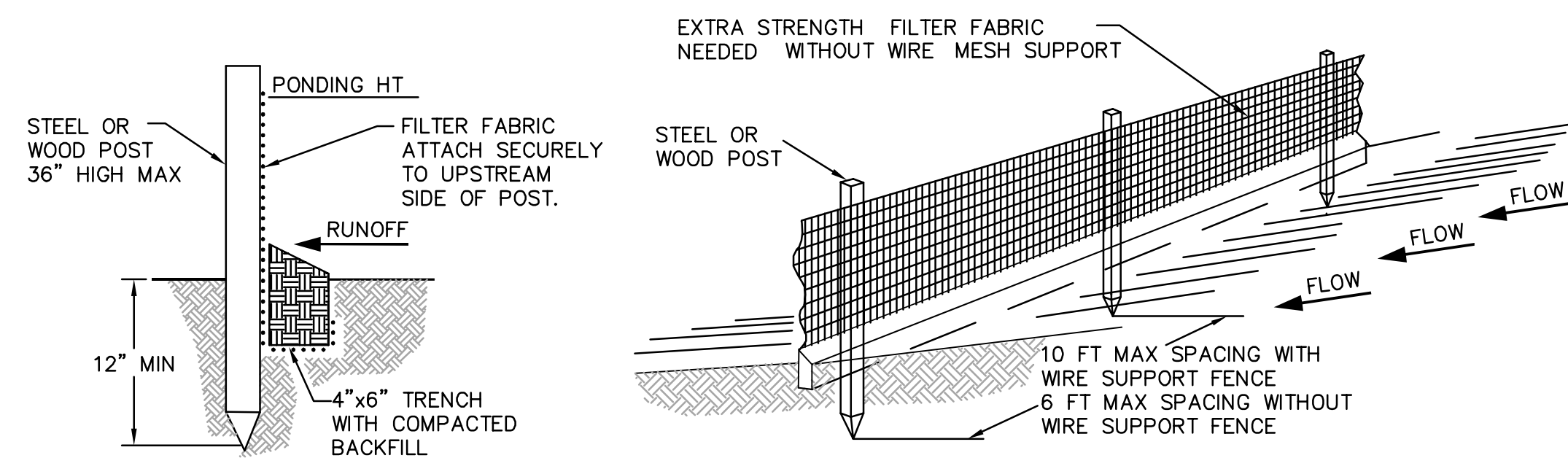

STANDARD DETAIL
TRENCH WITH NATIVE BACKFILL

- NOTES:**
- INSPECT AND REPAIR FENCE AFTER EACH STORM EVENT AND REMOVE SEDIMENT WHEN NECESSARY.
 - REMOVED SEDIMENT SHALL BE DEPOSITED TO AN AREA THAT WILL NOT CONTRIBUTE SEDIMENT OFF-SITE AND CAN BE PERMANENTLY STABILIZED.
 - SILT FENCE SHALL BE PLACED ON SLOPE CONTOURS TO MAXIMIZE PONDING EFFICIENCY.

2
SILT FENCE
NTS

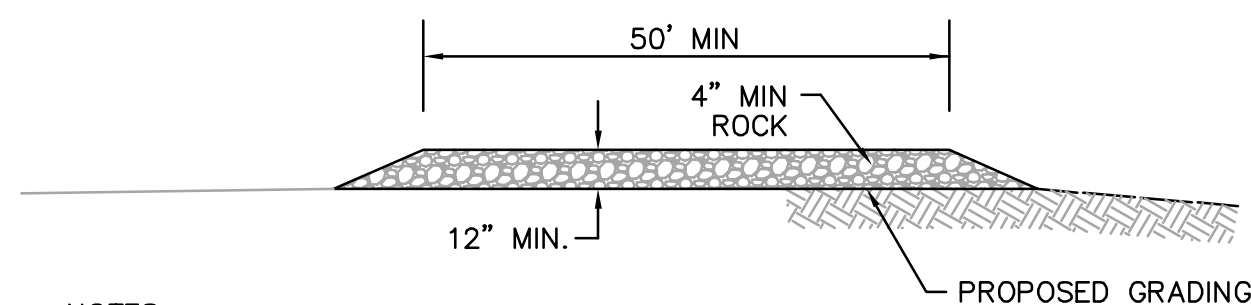

NOTES:

- THE LOCATIONS SHOWN ARE FOR INFORMATION ONLY. CONSTRUCTION ENTRANCES SHALL BE MAINTAINED IN A CONDITION THAT WILL PREVENT TRACKING OR FLOWING OF SEDIMENT ONTO PUBLIC RIGHT-OF-WAYS. THIS MAY REQUIRE PERIODIC TOP DRESSING WITH ADDITIONAL ROCK AS CONDITIONS DEMAND, AND REPAIR AND/OR CLEANOUT OF ANY MEASURES USE TO TRAP SEDIMENT. ALL SEDIMENT SPILLED, DROPPED, WASHED OR TRACKED ONTO PUBLIC RIGHT-OF-WAYS SHALL BE REMOVED IMMEDIATELY.
- WHEELS SHALL BE CLEANED TO REMOVE SEDIMENT PRIOR TO ENTRANCE ONTO PUBLIC RIGHT-OF-WAYS. WHEN WASHING IS REQUIRED, IT SHALL BE DONE ON AN AREA STABILIZED WITH CRUSHED ROCK THAT DRAINS INTO AN APPROVED SEDIMENT TRAP OR SEDIMENT BASIN. SEDIMENT SHALL BE PREVENTED FROM ENTERING THE STORM DRAIN, DITCH OR WATERCOURSE THROUGH USE OF INLET PROTECTION (E.G. GRAVELBAGS OR OTHER APPROVED METHODS).
- THE MATERIAL FOR CONSTRUCTION OF THE PAD SHALL BE 4" MIN ROCK.
- THE THICKNESS OF THE PAD SHALL NOT BE LESS THAN 12".
- THE WIDTH OF THE PAD SHALL NOT BE LESS THAN THE FULL WIDTH OF ALL POINTS OF INGRESS OR EGRESS, OR 25', WHICHEVER IS LESS.
- THE LENGTH OF THE PAD SHALL NOT BE LESS THAN 50'.

3
STABILIZED CONSTRUCTION ENTRANCE
NTS

