

RECEIVED

By Alameda County Environmental Health at 4:44 pm, Apr 01, 2014

March 25, 2014

Karel Detterman
Hazardous Materials Specialist
Alameda County Environmental Health
1131 Harbor Bay Parkway, Suite 250
Alameda, CA 94502-6577

**Subject: Milligan & Casentini Property
385 26th Street, Oakland, CA
Fuel Leak Case No. RO0003125**

Dear Ms. Detterman:

Enclosed is the *Data Gap Investigation Work Plan and Site Conceptual Model* for the subject LUFT site. In compliance with state and local regulations, electronic submittals of this report have been uploaded to the Geotracker database and the Alameda County ftp website.

I declare under penalty of perjury that the information and/or recommendations contained in the attached report are true and correct to the best of my knowledge.

Please call Tim Cook at Cook Environmental Services at (925) 478-8390 if you have questions or comments in regards to the technical content of this report.

Very truly yours,

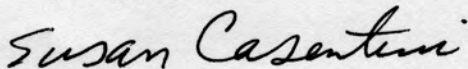

Susan Casentini

cc: Tim Cook, Cook Environmental Services, Inc.



Data Gap Investigation Work Plan and Site Conceptual Model

385 26th Street
Oakland, California 95209

PREPARED FOR:

Kyle Milligan and Susan Casentini
388 Belmont Street
Oakland, CA 94610-4821

SUBMITTED TO:

Karel Detterman, PG
Hazardous Materials Specialist
Alameda County Environmental Health
1131 Harbor Bay Parkway, Suite 250
Alameda, CA 94502-6577

PREPARED BY:

Cook Environmental Services, Inc.
1485 Treat Boulevard, Suite 203A
Walnut Creek, California

March 25, 2014

TABLE OF CONTENTS

PROFESSIONAL CERTIFICATION	iii
1.0 INTRODUCTION.....	1
1.1 General.....	1
1.2 Site Background	1
2.0 SITE CONCEPTUAL MODEL.....	2
3.0 DATA GAPS SUMMARY	3
4.0 PROPOSED INVESTIGATION	3
4.1 Fieldwork Preparation	3
4.2 Fieldwork.....	3
4.2.1 Soil Borings.....	4
4.2.2 Soil Vapor Borings	5
4.3 Reporting.....	5
5.0 PROJECT SCHEDULE	6

TABLES

Table 1 Summary of Soil Sample Results

Table 2 Site Conceptual Model

Table 3 Data Gaps Summary and Proposed Investigation

FIGURES

Figure 1 Site Location

Figure 2 UST and Soil Sample Locations

Figure 3 Proposed Soil Boring Locations

Figure 4 Proposed Soil Vapor Locations

APPENDICES

Appendix A Laboratory Analytical Report for UST Liquid

Appendix B Laboratory Analytical Report for Soil Samples

Appendix C Special Waste Profiles for Non-Hazardous Soil

Appendix D Manifests for Non-Hazardous Soil

Appendix E Special Waste Profiles for Non-RCRA Hazardous Soil

Appendix F Manifests for Non-RCRA Hazardous Soil

Appendix G Photographs of UST Removal

Appendix H UST Backfill Invoice and Weigh Tickets

Appendix I Soil Sampling SOPs

Appendix J Sample Boring Log

PROFESSIONAL CERTIFICATION

***Data Gap Investigation Work Plan and
Site Conceptual Model***

385 26th Street
Oakland, California 95209
Fuel Leak Case No. RO0003125

By: Cook Environmental Services, Inc.
Project No. 1095

March 25, 2014

Cook Environmental Services, Inc. prepared this document under the professional supervision of the person whose seal and signature appears hereon. No warranty, either expressed or implied, is made as to the professional advice presented herein. The analysis, conclusions and recommendations contained in this document are based upon Site conditions as they existed at the time of the investigation and they are subject to change.

The conclusions presented in this document are professional opinions based solely upon visual observations of the Site and vicinity, and interpretation of available information as described in this document. Cook Environmental Services, Inc. recognizes that the limited scope of services performed in execution of this investigation may not be appropriate to satisfy the needs, or requirements of other regulatory agencies or of other users. Any use or reuse of this document or its findings, conclusions or recommendations presented herein is at the sole risk of said user.

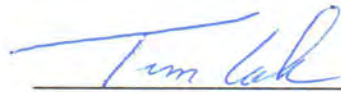

Tim Cook, P.E.
Principal



1.0 INTRODUCTION

1.1 General

This Work Plan was prepared by Cook Environmental Services, Inc. (CES) to describe methods and procedures to fill data gaps from a previous UST removal investigation and develop a Site Conceptual Model (SCM) for the leaking underground storage tank (UST) site located at 385 26th Street, Oakland, California 94612 (**Figure 1**).

Information used to prepare this work plan were derived from observations, site history, and laboratory data collected during the removal of one UST at the site. The local oversight program responsible for this case is Alameda County Environmental Health (ACEH).

The subject of this work plan is to provide a Site Conceptual Model (SCM) and identify data gaps to aid the full characterization of this site.

1.2 Site Background

A 1,200-gallon UST was discovered at the site by Paoli Construction, Inc. during grading activities at the site on February 13, 2013. Cook Environmental Services (CES) was hired by the property owner, the Kyle Milligan and Susan Casentini Trust, to inspect the UST on February 14, 2013. CES discovered a buried redwood tank approximately 12 feet in diameter that contained an unknown volume of heating oil.

The structural integrity of the redwood tank had been severely compromised and a large volume of heating oil had impacted surrounding soils. The UST was connected to a 4-inch diameter cast iron pipe that was probably connected to a fill spout behind the sidewalk on 26th Street. The location of the UST and the cast iron pipe are shown on **Figure 2**.

The City of Oakland Fire Department was notified and Cook Environmental Services, Inc (CES) filed an UST removal permit with the Fire Department on March 4, 2013. CES retained Fremouw Environmental Services, Inc (FES) to empty the UST. Since the redwood tank was badly decayed, no triple rinse or decontamination procedures could be performed. FES removed approximately 80 gallons of heating oil from the excavation on March 11, 2013. The receiving facility for the waste heating oil required that the liquid be sampled for PCBs prior to acceptance of the waste. A sample of the heating oil was collected on March 11, 2013 and analyzed for PCBs. PCBs were not detected. The laboratory report for this analysis is included as **Appendix A**. Two drums of heating oil were disposed of as non-RCRA hazardous waste.

CES excavated the UST and contaminated soil from March 11 to 13, 2013. Leroy Griffin of the City of Oakland Fire Prevention Bureau was onsite. Since the redwood tank was badly decomposed, it could not be removed intact and was taken out in pieces and placed in six 10-cubic yard roll-off bins along with contaminated soil. Three bins (36.5 tons) were profiled as non-hazardous and disposed at the Potrero Hills landfill in Suisun, California. The lab report from two soil samples collected from the UST excavation was used to profile the waste. This lab report is included in **Appendix B**. The special waste profiles used to characterize this soil as

non-hazardous are provided in **Appendix C**. The non-hazardous waste was disposed of at the Potrero Hills Landfill near Suisun, California. Non-hazardous waste manifests and weigh tickets for this soil are provided in **Appendix D**. Soil in two of the bins was classified as non-RCRA hazardous waste and was disposed at the U.S. Ecology landfill in Beatty, Nevada. The special waste profile used to characterize this soil as a non-RCRA hazardous material is provided in **Appendix E**. Hazardous waste manifests for these soils are provided in **Appendix F**.

The UST excavation extended to a depth of approximately 12 feet bgl. Photographs of the removal action are provided in **Appendix G**. After excavation activities were complete, CES collected two soil samples from the base of the excavation. Sample S1 was collected from the south end of the excavation at depth of approximately 10 feet below grade. Sample S2 was collected from the north end of the excavation (closest to 26th Street) at a depth of approximately 10 feet below grade. Sample locations are shown on **Figure 2**. Soil samples were collected from the bucket of the excavator and placed in stainless steel sample tubes, labeled and placed on ice in a cooler. Samples were handled using chain-of-custody procedures.

Samples were transported to McCampbell Analytical, Inc. in Pittsburg, California that same day and analyzed for the standard suite of analytes required of a UST containing heating oil. Analyses included total petroleum hydrocarbons as diesel (TPH-d) using EPA method 8015B modified; benzene, toluene, ethylbenzene and xylenes (BTEX) using EPA method 8021B; and naphthalene and MtBE using EPA method 8260B. The samples appeared to be contaminated due to staining and hydrocarbon odor.

BTEX and MtBE constituents were not detected in soil samples above laboratory detection limits. TPH-d concentrations range from 6,500 to 11,000 milligrams per kilogram (mg/kg). Naphthalene concentrations range from 10 to 14 mg/kg. **Table 1** summarizes soil sample results. As stated previously, the laboratory analytical report for these soil samples is provided in **Appendix B**.

The UST excavation was backfilled with clean recycle baserock from Marin Resource Recovery in San Rafael, California. An invoice and weigh tickets for the baserock is included in **Appendix H**.

2.0 SITE CONCEPTUAL MODEL

Table 2 presents the present SCM based on data from the site, nearby sites, historical research and owner knowledge of the site. The SCM describes our present understanding of regional and site geology and hydrogeology, nearby surface water bodies, past site activities, nearby water supply and monitoring wells, the source and volume of the release, presence of LNAPL, source removal activities, contaminants of concern (COCs), excavation backfill material, petroleum hydrocarbons in soil, petroleum hydrocarbons in groundwater and risk evaluation. Table 1 also identifies data gaps and the necessary information needed to fill the data gaps.

3.0 DATA GAPS SUMMARY

Table 2 describes in detail each data gap and provides the proposed investigation and rationale for filling each data gap. In some cases, the information to fill a data gap is provided in this work plan.

Data gaps are identified as follows:

1. Groundwater flow direction and gradient
2. Characterization of soil and groundwater contamination
3. Past uses of the site/UST
4. Indoor air intrusion/Outdoor air exposure
5. Map showing the UST and past soil sample locations (provided with this work plan)
6. Documentation of hazardous or non-hazardous status of excavated soil (provided with this work plan)
7. Documentation of clean imported excavation backfill (provided with this work plan).

4.0 PROPOSED INVESTIGATION

The following sections provide methods and procedures to fill data gaps identified in **Table 3**. Groundwater and soil samples will be collected from six temporary soil borings. Soil vapor borings may be warranted if soil samples from the bioattenuation zone meet LTCP criteria.

4.1 Fieldwork Preparation

USA Alert will be notified and proposed drilling locations will be marked with white paint. Utility owners will then mark the location of buried utilities at the site. If buried utilities are located within two feet of a proposed drilling location, then the proposed location will be adjusted.

A soil boring permit will be obtained from the Alameda County Department of Public Works. The well inspector assigned to this project will be notified at least 48 hours to beginning fieldwork. A Site Specific Health and Safety Plan will be submitted as part of the permitting process.

4.2 Fieldwork

The following sections describe methods and procedures to install soil borings and soil vapor borings.

4.2.1 Soil Borings

Six soil borings will be advanced at the site to a depth of 20 feet bgs. Five of the borings (SB-1 through SB-5) will be located in the source area and boring SB-6 will be located at near the southern property line, approximately 80 feet downgradient. The proposed locations of the borings are shown on **Figure 3**.

The rationale for placing five borings in the source area is to delineate the extent of hydrocarbon contamination in the source area. Boring SB-1 will be located in the center of the former UST. Borings SB-2 through SB-5 will be located approximately 12 feet from SB-1 in four directions like spokes extending from the center of a wheel. The former UST was shaped like a barrel and had a radius of approximately 6 feet. The purpose of placing borings SB-2 through SB-5 at a 12 foot radius from SB-1 is to locate these borings 6 feet outside the walls of the former UST. Boring SB-6 will be located approximately 80 feet south of the source area to determine if groundwater near the downgradient boundary of the site has been impacted by contaminants of concern (COCs)

The most contaminated soil samples (up to 3) from the source area based on visual staining, odor and PID readings will be selected for analysis of potential COCs. These samples will be analyzed for TPH-multi-range, BTEX, VOCs, SVOCs (including naphthalene) and CAM17 metals. This suite of analytes corresponds to guidelines for characterizing an “unknown fuel” in Table 2 of the *Tri-Regional Board Staff Recommendations for Preliminary Evaluation and Investigation of Underground Storage Tank Sites*, August 10, 1990. COCs for the remaining soil and groundwater samples will be selected based on the results of these samples. That is, if an analyte is detected above its ESL in the most contaminated samples, it will be considered to be a COC and will be analyzed in the remaining soil and groundwater samples.

Soil samples will be collected continuously using a dual tube sampler lined with acrylic tubes. Soil sampling standard operating procedures are provided in **Appendix I**. Soil samples will be collected in the source area (SB-1 through SB-5) at 8, 12, 16 and 20 feet bgs. One groundwater sample will be collected from each boring using either a disposable bailer or a peristaltic pump. Soil samples will be collected from SB-6 at 10 feet, 15 feet, and 20 feet bgs. One groundwater sample will be collected from this boring. Grab groundwater samples will be collected from the first encountered groundwater in each boring.

Borings will be logged using the Unified Soil Classification System and the geologist will prepare a detailed log for each boring that includes the project name, boring number, drilling contractor, date, start and finish time, drilling method, total depth, depth to water, type of sampler, name of the field geologist, depth of each soil sample, PID readings, graphic log and a lithologic description of soils encountered. A copy of a boring log is provided in **Appendix J**.

After all soil, groundwater or sol vapor samples have been collected, the borings will be abandoned in compliance with Alameda County requirements. Borings will be backfilled with

neat cement grout and will match the surrounding grade and conditions. An inspector from the Alameda County Department of Public Works will verify well abandonments.

4.2.2 Soil Vapor Borings

If soil samples collected from the bioattenuation zone (0 to 5 feet bgs) have an average TPH (TPH-d + TPH-g) value of less than 100 mg/kg, then two soil vapor probes will be advanced in the locations shown on **Figure 4**. The purpose of these borings will be to determine if the site qualifies for closure under LTCP Scenario 4.

Soil vapor sample borings will be located within two feet of the buildings at 381 and 385 26th Street. Soil vapor samples will be collected from a depth of 5 feet using direct push technology. Soil gas sampling will follow methods and procedures in the joint memorandum from DTSC and the Los Angeles RWQCB *Advisory - Active Soil Gas Investigations*, dated January 28, 2003.

The soil vapor sampling method consists of withdrawing of an aliquot of soil vapor from the subsurface with a sampling probe, followed by analysis of the withdrawn vapor. Soil vapor samples will be collected in gas-tight Summa containers and analyzed at an off-site laboratory. This method is quantitative and values will be reported in concentration units (e.g., mg/m³). This approach is the most common soil vapor collection method for a number of reasons, including ease of sample collection, opportunity for real-time data to direct further sampling, and the ability to acquire quantitative measurements.

Soil gas samples will be analyzed for TPH-g, TPH-d, BTEX, naphthalene, and the leak tracer compound (helium) by EPA Method TO-15, and fixed gases including oxygen, carbon dioxide, and methane by ASTM D-1946. Results for benzene, ethylbenzene and naphthalene will be compared to LTCP soil gas criteria. If oxygen concentrations are less than 4 percent, results will be compared to soil gas criteria with no bioattenuation zone and commercial land use. If oxygen concentrations are greater than 4 percent, results will be compared to soil gas criteria with bioattenuation zone and commercial land use.

4.3 Reporting

Upon completion of fieldwork and receipt of laboratory results, a Data Gaps Summary Report will be prepared. The report will summarize Site activities and will include the following information:

- A summary table of soil and groundwater sample results. Results will be compared to commercial/industrial environmental screening levels (ESLs)
- A figure showing soil boring locations and the location of the former UST
- A summary table of soil vapor sample results. Results will be compared to commercial/industrial environmental screening levels (ESLs)
- A figure showing soil vapor boring locations

- Laboratory reports, chain of custody forms and data evaluation QA/QC performance of the laboratory instruments
- Photographs of field activities
- An evaluation of site data with regard to LTCP closure criteria
- Conclusions, identification of any data gaps and recommendations for additional work, if necessary

If the data is sufficient to close this site under LTCP, then a Request for No Further Action Report will be prepared that meets LTCP criteria. If the data will not support site closure under LTCP then additional work to fill data gaps to advance the site towards closure will be recommended. The report will be prepared and stamped by a licensed professional engineer.

5.0 PROJECT SCHEDULE

Upon approval of this work plan by ACEH, a soil boring permit application will be submitted to the Alameda County Department of Public Works. Installation of soil borings will commence within 30 days of receipt of the boring permit. Installing the borings is expected to take one or two days. Analysis of soil, groundwater and soil vapor samples will take five working days. Upon review of soil sample data from the bioattenuation zone, a decision will be made regarding the collection of soil vapor samples. If soil vapor samples are warranted, fieldwork will be completed within 2 weeks of the receipt of soil sample data. The final report will be submitted to ACEH within 60 days of the completion of fieldwork.

TABLES

Table 1. Soil Sample Results
385 26th Street
Oakland, CA

Sample ID	Date	Depth (ft)	TPH-d	TPH-mo	Benzene	Toluene	Ethylbenzene	Xylenes	MtBE	Naphthalene
S-1	3/13/2013	12	11,000	11,000	<1.0	<1.0	<1.0	<1.0	<1.0	10
S-2	3/13/2013	12	6,500	5,200	<1.0	<1.0	<1.0	<1.0	<1.0	14
ESLs			110	1,000	0.044	2.9	3.3	2.3	0.023	1.2

All concentrations are in mg/kg

ESLs are for deep (>3m) at commercial/industrial sites where groundwater is a potential source of drinking water

Values above ESLs are in bold

**Table 2
Data Gaps Summary and Proposed Investigation**

CSM Element	CSM Sub-Element	Description	Data Gap Item #	Resolution
Geology and Hydrogeology	Site	<p>As described by CES in the Work Plan for UST Removal (2013), the lithology encountered in borings nearby at Benner Automotive located at 488 25th St. and the UST excavation at the Site consists predominantly of stiff cohesive clay with clayey sand and clayey gravel. The primary stratigraphic units at the Site are listed below, with the approximate ranges of depth (bgs) each unit was encountered across the Site:</p> <ul style="list-style-type: none"> • 0 to 18 feet bgs: brown, stiff, cohesive clay at 385 26th St. • 18 to 23 feet bgs: wet, clayey sand at 488 25th St. • 23 to 25 feet bgs: wet, clayey gravel at 488 25th St. <p>Groundwater was not encountered in the UST excavation (12 fbg). Expect to encounter groundwater at 14 to 18 fbg. The depths vary based on the season with the highest elevations occurring during the wet winter months and the lowest elevations occurring in the dry autumn months.</p>	1. There are no monitoring wells on site. The onsite groundwater flow direction and gradient is not known. There are, or were, monitoring wells at three nearby sites	No groundwater wells are planned for the site at this time. Historic groundwater data from nearby monitoring wells may be adequate.
Geology and Hydrogeology	Regional	The regional groundwater flow direction based on topography is expected to be south to southwesterly toward San Francisco Bay.		NA
Surface Water Bodies		The closest surface water body is Lake Merritt, which is approximately 2,000 feet southeast of the site.		NA
Past Site Activities		According to City of Oakland historian, Betty Marvin, the site was occupied by two homes from 1902 until at least the mid-1930's. The 1,200 gallon UST was located adjacent to the homes. The back of the site was part of a large laundry facility facing 25th Street. According to Ms. Marvin, the laundry facility was a conventional laundry using soap and water and not a laundry using dry cleaning chemicals such as perchloroethane (PCE). After the homes were removed in the 1930's, a machine shop occupied the site until 2006. In 2006 the machine shop was removed. The present building was constructed in 2006-07. In 2008 it was purchased by Kyle Milligan and Susan Casentini. The site is presently used as an artist's studio. Supplement site history and attempt to determine UST content(s) based on past site use.	3. Need a better description of past site history	Order Sanborne map, research past site occupants and operations.
Nearby Wells		The State Water Resource Quality Control Board (RWQCB) Geotracker GAMA website provides the locations of water supply		NA

**Table 2
Data Gaps Summary and Proposed Investigation**

CSM Element	CSM Sub-Element	Description	Data Gap Item #	Resolution
		wells proximal to the site. The nearest supply well is located approximately 4.3 km southwest of the site on Alameda Island. There are multiple monitoring wells in the vicinity of the site including those at Benner Automotive at 488 25 th St., Shell #12-9450 at 2800 Telegraph and Chevron #9-2506 at 2630 Broadway.		
Release Source and Volume		One redwood UST (1,200-gallon) is considered the main source of the release of fuel hydrocarbons that have been detected in soil and groundwater beneath the Site. The redwood tank had one or more holes at the time of removal. The tank broke into two pieces as the staves were removed. Soil surrounding the tank was stained and had a strong kerosene odor. The release from the tanks was discovered on February 13, 2013 during grading activities in the parking lot next to the building. The volume of the release is not known.	2. Additional soil and groundwater data is required in the source area.	See data gaps table. Additional soil borings will be advanced in the source area. Groundwater monitoring wells will not be installed at this time.
LNAPL		Light non-aqueous phase liquid was observed in the UST excavation during removal activities. Soils saturated with LNAPL were excavated and disposed of offsite. A sample of the LNAPL was collected on 3/11/13 and analyzed for organochlorine pesticides and PCBs. Neither pesticides nor PCBs were detected. Two soil samples were collected from the base of the UST excavation on 3/13/13 and analyzed for TPH-d, TPH-mo, BTEX, MtBE and naphthalene. Concentrations of TPH-d in sample S1 (11,000 mg/kg) and sample S2 (6,500 mg/kg) may indicate the presence of LNAPL.	2. Need water samples in the source area to determine if LNAPL is present.	Water samples will be collected from soil borings in source area. Check gw sample for floating product. Lab results also may indicate the presence of LNAPL.
Source Removal Activities		Approximately 60 cubic yards (CY) of contaminated soil was excavated from the UST pit during tank removal activities. The excavation was approximately 12 feet deep. Contaminated soil was easily identified due to its gray color and distinctive kerosene odor. Most of the gray stained soil was excavated but some had to be left insitu due to the close proximity of the neighboring brick structure (see photos). As mentioned previously, soil samples S1 and S2 were collected from the base of the excavation. Groundwater was not encountered in the excavation. The redwood tank debris and the cast iron fill pipe were disposed of with the contaminated soil. There has been no other source removal	2. Soil contamination at depth (12-foot bgs and deeper) is not well characterized. Additional soil sampling in the source area below 12 fbg is required.	Soil borings are proposed, as discussed in the data gaps table.

**Table 2
Data Gaps Summary and Proposed Investigation**

CSM Element	CSM Sub-Element	Description	Data Gap Item #	Resolution
		activity conducted at the Site.		
Source Removal Activities		ACEH requested a map showing location of UST, location of fill pipe, size of excavation and soil sample locations	5. Map showing all requested items	See Figure 2
Source Removal Activities		ACEH requested rationale for disposing of 20 CY as hazardous and 40 CY as non-haz	6. Data supporting characterization of some soils as hazardous and some as non-haz	See Appendix B though F
Backfill Material		ACEH requested information regarding the UST excavation backfill material. The excavation was backfilled with clean base rock from Marin Resource and Recycle (see invoice).	7. Backup for imported UST excavation backfill material	Invoice and weigh tickets for clean base rock from Marin Resource Recovery in Appendix H
Contaminants of Concern		Based on site history and the materials of construction (redwood) an assumption was made that the UST contained only heating oil. The Tri-Regional guidelines for heating oil tanks identify COCs as TPH-d, BTEX. However, there is no record of liquids stored in the UST. Based on discussions with ACEH, potential COCs could be TPH-g, TPH-d, BTEX, VOCs, SVOCs and CAM17 metals.	2. Need to identify all COCs related to the source	Collect several contaminated soil samples in source area and analyze for TPH-g, TPH-d, BTEX, VOCs, SVOCs and CAM17 metals. Adjust known COC list accordingly.
Petroleum Hydrocarbons in Soil		Two samples were analyzed as part of the UST removal action. These samples were collected from each end of the bottom of the UST excavation at a depth of 12 feet bgs. TPH-d, TPH-mo and naphthalene were detected above ESLs. BTEX was not detected.	2. Additional soil sampling is required to better define the lateral and vertical extent of contamination.	Additional soil borings to be advanced, as described in the data gaps table.
Petroleum		Groundwater was not encountered during the removal of the UST.	2. There is no	Groundwater

**Table 2
Data Gaps Summary and Proposed Investigation**

CSM Element	CSM Sub-Element	Description	Data Gap Item #	Resolution
Hydrocarbons in Groundwater		No groundwater samples have been collected. There are no permanent monitoring wells located at the Site. As such, the groundwater flow direction across the Site cannot be evaluated. This is a significant data gap. The scope of work presented in this work plan includes the installation of temporary soil borings and the collection of groundwater samples.	groundwater monitoring data	samples will be collected from soil borings, as discussed in the data gaps table.
Risk Evaluation		<p>This CSM identifies the primary source; impacted media; release mechanism(s); secondary source(s); exposure route; potential receptors (residential, commercial/industrial worker, and construction worker), and an assessment of whether the exposure route/pathway is potentially complete, incomplete, or insignificant. Potential exposure routes include incidental ingestion, dermal contact, dust inhalation, and vapor inhalation.</p> <p>The exposure route for direct contact with contaminated soil and incidental ingestion are incomplete since the site is paved. The exposure routes for inhalation (via vapor intrusion into nearby buildings or outdoor air exposure) and exposure to construction workers excavating in the contaminated area are potential exposure pathways.</p> <p>For leaching of contaminants from soil to groundwater, the ingestion and dermal pathways for groundwater are considered incomplete, except for the construction worker, as shallow groundwater in this area is not currently a drinking water resource. For the construction worker, incidental ingestion and dermal contact is a potential pathway. For volatilization from groundwater to outdoor air, the exposure pathway is considered insignificant due to dilution effects that take place outdoors. For indoor air, volatilization from groundwater to indoor air is considered a potentially complete pathway.</p>	3. There is no data to evaluate the health risk from volatilization of contaminants to human receptors in nearby buildings and outdoor air. Buildings on both sides of the source area are slab on grade construction.	<p>If soil samples next to building from 0 to 5 feet bgs are less than 100 mg/kg TPH (i.e., a viable bioattenuation zone) then collect soil vapor samples from one boring next to the building at 385 26th St and one next to the building at 381 26th Street as described in the Data Gaps table.</p> <p>Compare soil data to direct contact thresholds in Table 1 of LTCP</p>

Table 3
Data Gaps Summary and Proposed Investigation

Item	Data Gap Item #	Proposed Investigation	Rationale	Analyses
1	<p>Groundwater flow direction and gradient at the site is unknown.</p> <p>There are several LUST sites within 1,000 feet of the site. One of these sites, Dave's Station at 2250 Telegraph has groundwater elevation data from Feb 2014. The Chevron Station at 2630 Broadway has groundwater elevation data from Nov 2012.</p>	<p>No groundwater monitoring wells will be installed at this time. A fairly accurate estimation of groundwater direction can be derived from nearby offsite monitoring well data.</p>	<p>ACEH agreed with this approach in a meeting dated Jan 28, 2014.</p>	<p>NA</p>
2	<p>The present data set does not adequately characterize soil and groundwater contamination (if any) that may remain on site after removal of contaminated soil (60 CY, approximately 12 feet bgs) The current soil data is two soil samples collected from the base of the UST excavation.</p> <p>Lithology below is not adequately characterized.</p>	<p>Source Area: Five soil borings will be drilled in the source area to a depth of 20 feet bgs. Soil samples will be collected at 8, 12, 16 and 20 feet bgs from soil borings SB-1 through SB-5. One groundwater sample will be collected from each boring.</p> <p>Downgradient: One soil boring will be drilled near the south edge of the property to a depth of 20 feet bgs. Soil samples will be collected at 10 feet, 15 feet, and 20 feet bgs. One groundwater sample will be collected from this boring.</p> <p>Borings will be logged using the Unified Soil Classification System.</p> <p>Grab groundwater samples will be collected from the first encountered groundwater in each boring.</p>	<p>Source Area: Soil samples will be collected from five borings starting at 8 feet bgs which corresponds to depth of the bottom of the UST. Soil borings will be located as shown in the work plan figure. Boring SB-1 will be located at the center of the source area. The remaining four borings will be located 12 feet from SB-1 like spokes from a wheel hub. PID meter and visual observations will be used to select the most contaminated soil sample for additional analyses</p> <p>Step out boring: Step out boring SB-6 to be installed near the south property line.</p>	<p>The most contaminated soil samples (up to 3) from the source area based on visual staining, odor and PID readings will be selected for analysis of potential COCs. These samples will be analyzed for TPH-multi-range, BTEX, VOCs, SVOCs (including naphthalene) and CAM17 metals. COCs for the remaining soil and groundwater samples will be selected based on the results of these samples.</p>

**Table 3
Data Gaps Summary and Proposed Investigation**

Item	Data Gap Item #	Proposed Investigation	Rationale	Analyses
3	Determine past usage of site (past contents of UST?)	Although we have contacted the City of Oakland historian and aerial photos, additional documentation of past site usage is appropriate to determine usage of UST and contents contained therein.	Obtain Sanborne Map to determine historic usage of site	NA
4	Indoor air intrusion/outdoor air exposure routes	Evaluate soil sample results from bioattenuation zone (0 to 5 feet bgs). If TPH \leq 100 mg/kg, then advance two soil vapor borings, one near each adjacent building	Buildings are slab on grade. Advance soil vapor boring to 5 feet. Use data to establish bioattenuation zone (Scenario 4 of LTCP)	TPH-g, TPH-d, BTEX, naphthalene, and the leak tracer compound (helium) and fixed gases including oxygen, carbon dioxide, and methane
5	Map showing UST and past soil sample locations	NA	See Figure 2	NA
6	Documentation of haz vs. non-haz status of contaminated soil	NA	See lab report, profile and manifests from disposal sites (Appendix B through Appendix F)	NA
7	Proof of clean imported backfill for UST excavation	NA	See invoices and weigh tickets from Marin Resource Recovery in Appendix H	NA

FIGURES

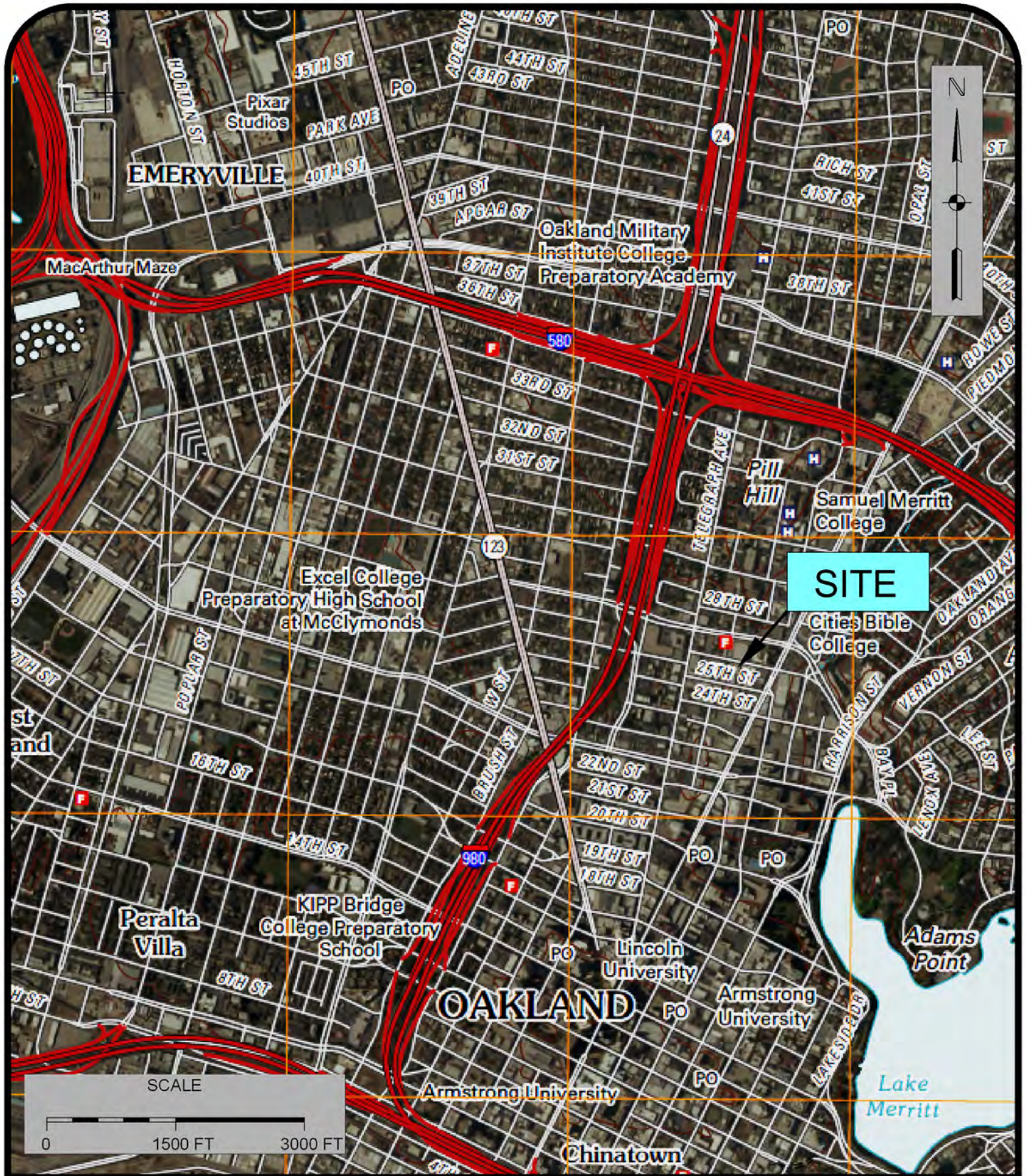

Cook Environmental Services, Inc.

1485 Treat Blvd. Ste. 203A
 Walnut Creek, CA 94597
 (925) 478-8390 work
 (925) 787-6869 cell
 tcook@cookenvironmental.com

Site Location Map
385 26th St.
Oakland, CA 94612

Project 1095
Date: 3/25/14
Scale: 1"=1500 FT

Figure :
1

26th Street

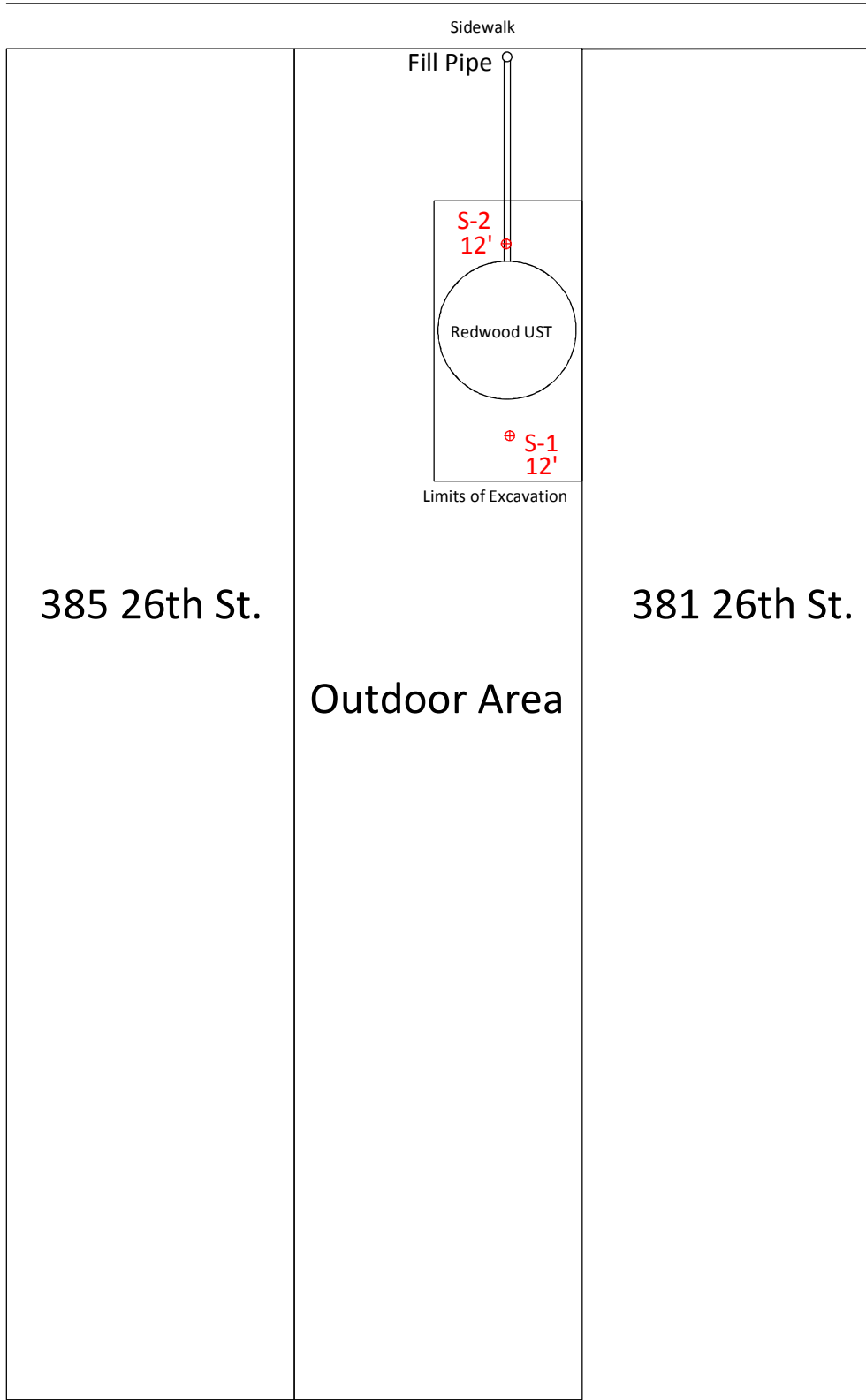
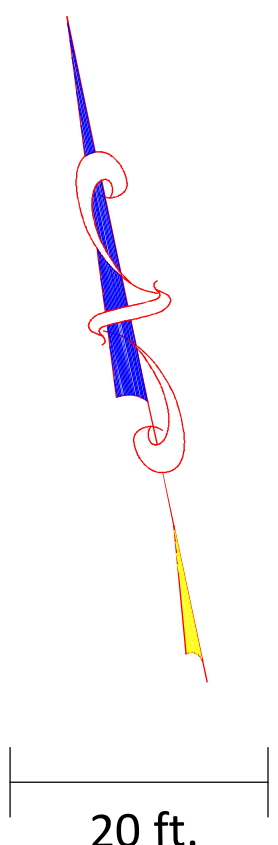

Cook Environmental Services, Inc.

1485 Treat Blvd. Ste 203A
Walnut Creek, CA 94597
(925) 478-8390
tcook@cookenvironmental.com

UST and Soil Sample Locations
385 26th Street
Oakland, CA

Project #: 1095	Figure:
Date: 3/25/14	2
Scale: as shown	

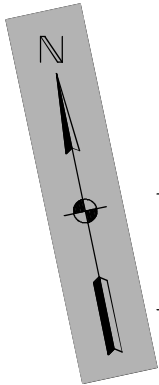

26th Street

Sidewalk

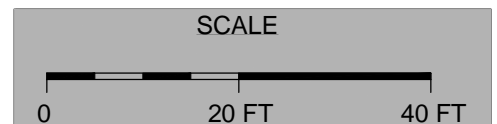
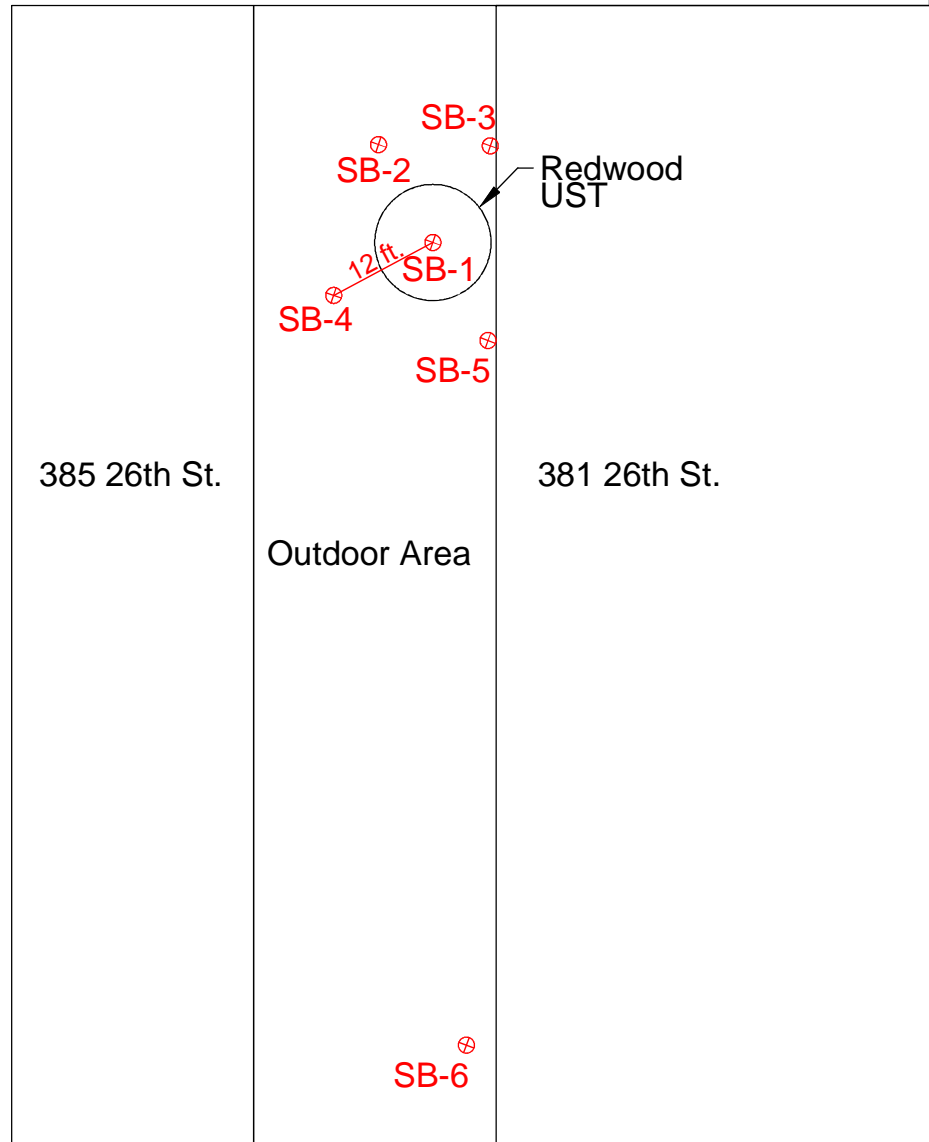

Cook Environmental Services, Inc.
1485 Treat Blvd. Ste. 203A
Walnut Creek, CA 94597
(925) 478-8390 work
(925) 787-6869 cell
tcook@cookenvironmental.com

Proposed Soil Borings
385 26th St.
Oakland, CA 94612

Project 1095
Date: 3/25/14
Scale: 1" = 20 FT

Figure :
3

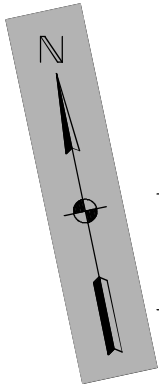

26th Street

Sidewalk

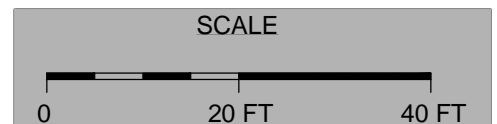
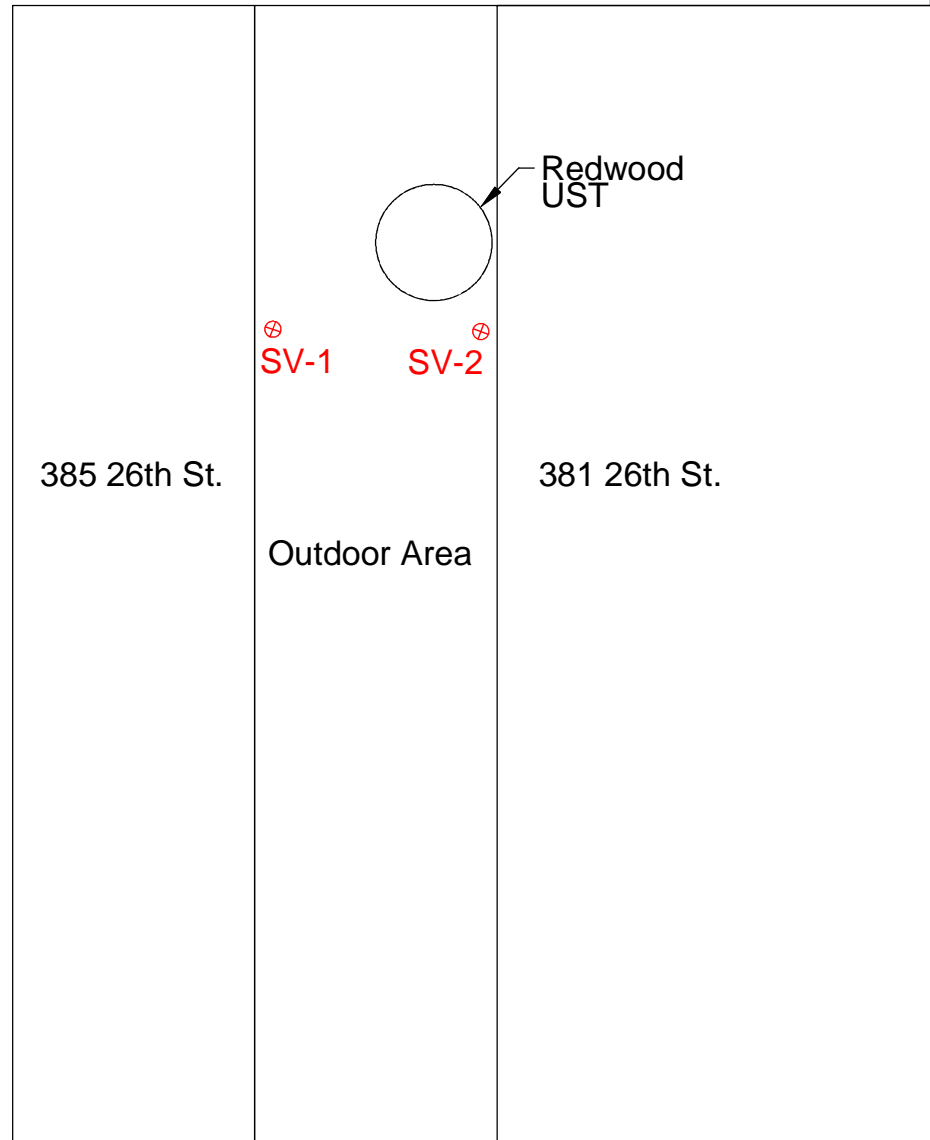

Cook Environmental Services, Inc.
1485 Treat Blvd. Ste. 203A
Walnut Creek, CA 94597
(925) 478-8390 work
(925) 787-6869 cell
tcook@cookenvironmental.com

Proposed Soil Vapor Borings
385 26th St.
Oakland, CA 94612

Project 1095	Figure :
Date: 3/25/14	4
Scale: 1" = 20 FT	

APPENDIX A
Laboratory Analytical Report
for UST Liquid



Analytical Report

Cook Environmental Services, Inc. 1485 Treat Blvd, Ste. 203A Walnut Creek, CA 94597	Client Project ID: #1095; Paoli Construction	Date Sampled: 03/11/13
		Date Received: 03/11/13
	Client Contact: Tim Cook	Date Reported: 03/12/13
	Client P.O.:	Date Completed: 03/12/13

WorkOrder: 1303304

March 12, 2013

Dear Tim:

Enclosed within are:

- 1) The results of the **1** analyzed sample from your project: **#1095; Paoli Construction,**
- 2) QC data for the above sample, and
- 3) A copy of the chain of custody.

All analyses were completed satisfactorily and all QC samples were found to be within our control limits.

If you have any questions or concerns, please feel free to give me a call. Thank you for choosing McC Campbell Analytical Laboratories for your analytical needs.

Best regards,

Angela Rydelius
 Laboratory Manager
 McC Campbell Analytical, Inc.

The analytical results relate only to the items tested.

303304

RUSH

McCAMPBELL ANALYTICAL, INC.
1534 Willow Pass Rd.
Pittsburg, CA 94565

Website: www.mccampbell.com Email: main@mccampbell.com
Telephone: (877) 252-9262 Fax: (925) 252-9269

CHAIN OF CUSTODY-RECORD

TURN AROUND TIME
 RUSH 24 HR 48 HR 72 HR 5 DAY
 EDF Required? Coelt (Normal) Yes Write On (DW) No

Report To: Tim Cook Bill To:
 Company: Cook Environmental Services, Inc.
 1485 Treat Blvd, Suite 203A
 Walnut Creek, CA 94597 E-Mail: tcCook@cookenvironmental.com
 Tele: (925) 478-8390 Fax: (925) 478-8394
 Project #: 1095 Project Name: Paoli Construction
 Project Location: 385 26th St., Oakland
 Sampler Name & Signature:

Analysis Request										Other	Comments							
BTEX (8021B)	TPH as Diesel (8015) & TPHmo	EPA 8260 - naphthalene	8010-Plus-2-methyl naphthalene PCBs (8020)	EPA 601 / 8010 / 8021	BTEX ONLY (EPA 602 / 8020)	EPA 608 / 8081	EPA 608 / 8082 PCB's ONLY	EPA 8140 / 8141	EPA 8150 / 8151	EPA 8260 (9 oxys only)	EPA 525 / 625 / 8270	PAH's / PNA's by EPA 625 / 8270 / 8310	CAM-17 Metals (6010 / 6020)	LUFT 5 Metals (6010 / 6020)	Lead (200.8 / 200.9 / 6010)	SPLC Leach	TTLc Leach	Filter Samples for Metals analysis: Yes / No
			X															

SAMPLE ID (Field Point Name)	LOCATION	SAMPLING		# Containers	Type Containers	MATRIX					METHOD PRESERVED								
		Date	Time			Water	Soil	Air	Sludge	Other	ICE	HCL	HNO ₃	Other					
0-1	heating oil from UST	3/11	9am	1	1 liter	X						X							

Relinquished By: *[Signature]* Date: 3/11/13 Time: 1645 Received By: *[Signature]*
 Relinquished By: *[Signature]* Date: 3/11/13 Time: 1745 Received By: *[Signature]*
 Relinquished By: _____ Date: _____ Time: _____ Received By: _____

ICE# 3.7
 GOOD CONDITION _____
 HEAD SPACE ABSENT _____
 DECHLORINATED IN LAB _____
 APPROPRIATE CONTAINERS _____
 PRESERVED IN LAB _____
 COMMENTS:
 VOAS | O&G | METALS | OTHER
 PRESERVATION | pH<2



1534 Willow Pass Rd
 Pittsburg, CA 94565-1701
 (925) 252-9262

CHAIN-OF-CUSTODY RECORD

WorkOrder: 1303304

ClientCode: CESW

WaterTrax
 WriteOn
 EDF
 Excel
 EQuIS
 Email
 HardCopy
 ThirdParty
 J-flag

Report to:
 Tim Cook
 Cook Environmental Services, Inc.
 1485 Treat Blvd, Ste. 203A
 Walnut Creek, CA 94597
 (925) 478-8390 FAX: 925-937-1759

Email: tcook@cookenvironmental.com
cc:
PO:
ProjectNo: #1095; Paoli Construction

Bill to:
 Tim Cook
 Cook Environmental Services, Inc.
 1485 Treat Blvd, Ste. 203A
 Walnut Creek, CA 94597

Requested TAT: 1 day

Date Received: 03/11/2013

Date Printed: 03/11/2013

Lab ID	Client ID	Matrix	Collection Date	Hold	Requested Tests (See legend below)													
					1	2	3	4	5	6	7	8	9	10	11	12		
1303304-001	0-1	Water	3/11/2013 9:00	<input type="checkbox"/>	A													

Test Legend:

1	8081PCB_W	2		3		4		5	
6		7		8		9		10	
11		12							

Prepared by: Jena Alfaro

Comments:

NOTE: Soil samples are discarded 60 days after results are reported unless other arrangements are made (Water samples are 30 days).
 Hazardous samples will be returned to client or disposed of at client expense.



Sample Receipt Checklist

Client Name: **Cook Environmental Services, Inc.**

Date and Time Received: **3/11/2013 5:58:02 PM**

Project Name: **#1095; Paoli Construction**

LogIn Reviewed by: **Jena Alfaro**

WorkOrder N°: **1303304** Matrix: Water

Carrier: Rob Pringle (MAI Courier)

Chain of Custody (COC) Information

Chain of custody present?	Yes <input checked="" type="checkbox"/>	No <input type="checkbox"/>
Chain of custody signed when relinquished and received?	Yes <input checked="" type="checkbox"/>	No <input type="checkbox"/>
Chain of custody agrees with sample labels?	Yes <input checked="" type="checkbox"/>	No <input type="checkbox"/>
Sample IDs noted by Client on COC?	Yes <input checked="" type="checkbox"/>	No <input type="checkbox"/>
Date and Time of collection noted by Client on COC?	Yes <input checked="" type="checkbox"/>	No <input type="checkbox"/>
Sampler's name noted on COC?	Yes <input checked="" type="checkbox"/>	No <input type="checkbox"/>

Sample Receipt Information

Custody seals intact on shipping container/cooler?	Yes <input type="checkbox"/>	No <input type="checkbox"/>	NA <input checked="" type="checkbox"/>
Shipping container/cooler in good condition?	Yes <input checked="" type="checkbox"/>	No <input type="checkbox"/>	
Samples in proper containers/bottles?	Yes <input checked="" type="checkbox"/>	No <input type="checkbox"/>	
Sample containers intact?	Yes <input checked="" type="checkbox"/>	No <input type="checkbox"/>	
Sufficient sample volume for indicated test?	Yes <input checked="" type="checkbox"/>	No <input type="checkbox"/>	

Sample Preservation and Hold Time (HT) Information

All samples received within holding time?	Yes <input checked="" type="checkbox"/>	No <input type="checkbox"/>	
Container/Temp Blank temperature	Cooler Temp: 3.7°C		NA <input type="checkbox"/>
Water - VOA vials have zero headspace / no bubbles?	Yes <input type="checkbox"/>	No <input type="checkbox"/>	No VOA vials submitted <input checked="" type="checkbox"/>
Sample labels checked for correct preservation?	Yes <input checked="" type="checkbox"/>	No <input type="checkbox"/>	
Metal - pH acceptable upon receipt (pH<2)?	Yes <input type="checkbox"/>	No <input type="checkbox"/>	NA <input checked="" type="checkbox"/>
Samples Received on Ice?	Yes <input checked="" type="checkbox"/>	No <input type="checkbox"/>	

(Ice Type: WET ICE)

* NOTE: If the "No" box is checked, see comments below.

 Comments:



Cook Environmental Services, Inc. 1485 Treat Blvd, Ste. 203A Walnut Creek, CA 94597	Client Project ID: #1095; Paoli Construction	Date Sampled: 03/11/13
	Client Contact: Tim Cook	Date Received: 03/11/13
	Client P.O.:	Date Extracted: 03/11/13
		Date Analyzed: 03/11/13

Organochlorine Pesticides by GC-ECD (8080 Basic Target List) + PCBs*

Extraction Method: SW3510C

Analytical Method: SW8081A/8082

Work Order: 1303304

Lab ID	1303304-001A				Reporting Limit for DF =1	
Client ID	0-1				S	W
Matrix	W					
DF	20					

Compound	Concentration			µg/kg	µg/L
Aldrin	ND<0.10			NA	0.005
a-BHC	ND<0.20			NA	0.01
b-BHC	ND<0.10			NA	0.005
d-BHC	ND<0.10			NA	0.005
g-BHC	ND<0.40			NA	0.02
Chlordane (Technical)	ND<2.0			NA	0.1
a-Chlordane	ND<1.0			NA	0.05
g-Chlordane	ND<1.0			NA	0.05
p,p-DDD	ND<0.20			NA	0.01
p,p-DDE	ND<0.20			NA	0.01
p,p-DDT	ND<0.20			NA	0.01
Dieldrin	ND<0.20			NA	0.01
Endosulfan I	ND<0.40			NA	0.02
Endosulfan II	ND<0.40			NA	0.02
Endosulfan sulfate	ND<1.0			NA	0.05
Endrin	ND<0.20			NA	0.01
Endrin aldehyde	ND<1.0			NA	0.05
Endrin ketone	ND<1.0			NA	0.05
Heptachlor	ND<0.20			NA	0.01
Heptachlor epoxide	ND<0.20			NA	0.01
Hexachlorobenzene	ND<10			NA	0.5
Hexachlorocyclopentadiene	ND<20			NA	1.0
Methoxychlor	ND<2.0			NA	0.1
Toxaphene	ND<10			NA	0.5
Aroclor1016	ND<10			NA	0.5
Aroclor1221	ND<10			NA	0.5
Aroclor1232	ND<10			NA	0.5
Aroclor1242	ND<10			NA	0.5
Aroclor1248	ND<10			NA	0.5
Aroclor1254	ND<10			NA	0.5
Aroclor1260	ND<10			NA	0.5
PCBs, total	ND<10			NA	0.5

Surrogate Recoveries (%)

%SS:	108			
Comments	a3			

* water samples in µg/L, soil/sludge/solid samples in mg/kg, wipe samples in µg/wipe, filter samples in µg/filter, product/oil/non-aqueous liquid samples and all TCLP & SPLP extracts are reported in mg/L.

ND means not detected above the reporting limit/method detection limit; N/A means analyte not applicable to this analysis; %SS = Percent Recovery of Surrogate Standard; DF = Dilution Factor.

surrogate diluted out of range or surrogate coelutes with another peak.

a3) sample diluted due to high organic content.



QC SUMMARY REPORT FOR SW8081A/8082

W.O. Sample Matrix: Water

QC Matrix: Water

BatchID: 75381

WorkOrder: 1303304

EPA Method: SW8081A/8082		Extraction: SW3510C				Spiked Sample ID: N/A			
Analyte	Sample	Spiked	MS	MSD	MS-MSD	LCS	Acceptance Criteria (%)		
	µg/L	µg/L	% Rec.	% Rec.	% RPD	% Rec.	MS / MSD	RPD	LCS
Aldrin	N/A	1.25	N/A	N/A	N/A	95	N/A	N/A	70 - 130
g-BHC	N/A	1.25	N/A	N/A	N/A	100	N/A	N/A	70 - 130
p,p-DDT	N/A	1.25	N/A	N/A	N/A	85.7	N/A	N/A	70 - 130
Dieldrin	N/A	1.25	N/A	N/A	N/A	109	N/A	N/A	70 - 130
Endrin	N/A	1.25	N/A	N/A	N/A	102	N/A	N/A	70 - 130
Heptachlor	N/A	1.25	N/A	N/A	N/A	95.9	N/A	N/A	70 - 130
%SS:	N/A	1.25	N/A	N/A	N/A	81	N/A	N/A	70 - 130

All target compounds in the Method Blank of this extraction batch were ND less than the method RL with the following exceptions:
 NONE

BATCH 75381 SUMMARY

Lab ID	Date Sampled	Date Extracted	Date Analyzed	Lab ID	Date Sampled	Date Extracted	Date Analyzed
1303304-001A	03/11/13 9:00 AM	03/11/13	03/11/13 11:36 PM				

MS = Matrix Spike; MSD = Matrix Spike Duplicate; LCS = Laboratory Control Sample; LCSD = Laboratory Control Sample Duplicate; RPD = Relative Percent Deviation.
 $\% \text{ Recovery} = 100 * (\text{MS} - \text{Sample}) / (\text{Amount Spiked})$; $\text{RPD} = 100 * (\text{MS} - \text{MSD}) / ((\text{MS} + \text{MSD}) / 2)$.
 MS / MSD spike recoveries and / or %RPD may fall outside of laboratory acceptance criteria due to one or more of the following reasons: a) the sample is inhomogenous AND contains significant concentrations of analyte relative to the amount spiked, or b) the spiked sample's matrix interferes with the spike recovery.
 N/A = not enough sample to perform matrix spike and matrix spike duplicate.
 NR = analyte concentration in sample exceeds spike amount for soil matrix or exceeds 2x spike amount for water matrix or sample diluted due to high matrix or analyte content.

APPENDIX B
Laboratory Analytical Report
for Soil Samples



Analytical Report

Cook Environmental Services, Inc. 1485 Treat Blvd, Ste. 203A Walnut Creek, CA 94597	Client Project ID: #1095; Paoli Construction	Date Sampled: 03/13/13
		Date Received: 03/13/13
	Client Contact: Tim Cook	Date Reported: 03/19/13
	Client P.O.:	Date Completed: 03/19/13

WorkOrder: 1303385

March 19, 2013

Dear Tim:

Enclosed within are:

- 1) The results of the **2** analyzed samples from your project: **#1095; Paoli Construction,**
- 2) QC data for the above samples, and
- 3) A copy of the chain of custody.

All analyses were completed satisfactorily and all QC samples were found to be within our control limits.

If you have any questions or concerns, please feel free to give me a call. Thank you for choosing McC Campbell Analytical Laboratories for your analytical needs.

Best regards,

Angela Rydelius
 Laboratory Manager
 McC Campbell Analytical, Inc.

The analytical results relate only to the items tested.

1303385

McCAMPBELL ANALYTICAL, INC.
 1534 Willow Pass Rd.
 Pittsburg, CA 94565
 Website: www.mccampbell.com Email: main@mccampbell.com
 Telephone: (877) 252-9262 Fax: (925) 252-9269

CHAIN OF CUSTODY RECORD
TURN AROUND TIME
 RUSH 24 HR 48 HR 72 HR 5 DAY
 EDF Required? Coelt (Normal) Yes Write On (DW) No

Report To: Tim Cook Bill To:
 Company: Cook Environmental Services, Inc.
 1485 Treat Blvd, Suite 203A
 Walnut Creek, CA 94597 E-Mail: tcook@cookenvironmental.com
 Tele: (925) 478-8390 Fax: (925) 478-8394
 Project #: 1095 Project Name: Paoli Construction
 Project Location: 385 26th St., Oakland
 Sampler Name & Signature: *[Signature]*

Analysis Request										Other	Comments								
BTEX (8021B)	TPH as Diesel (8015) & TPHmo	EPA 8260 - naphthalene	8310 Pluse 2-methyl naphthalene	EPA 601 / 8010 / 8021	BTEX ONLY (EPA 602 / 8020)	EPA 608 / 8081	EPA 608 / 8082 PCB's ONLY	EPA 8140 / 8141	EPA 8150 / 8151	EPA 8260 (9 oxy's only)	EPA 525 / 625 / 8270	PAH's / PNA's by EPA 625 / 8270 / 8310	CAM-17 Metals (6010 / 6020)	LUFT 5 Metals (6010 / 6020)	Lead (200.8 / 200.9 / 6010)	SPLC Leach	TTLc Leach	Filter Samples for Metals analysis: Yes / No	
S-1	are	3/13	1	tube	X														
S-2	near street	3/13	1	tube	X														

Relinquished By: *[Signature]* Date: 3/13/13 Time: 12:29 Received By: *[Signature]*
 Relinquished By: *[Signature]* Date: 3/13/13 Time: 1:15 Received By: *[Signature]*
 Relinquished By: _____ Date: _____ Time: _____ Received By: _____

ICE/r 2.8
 GOOD CONDITION _____
 HEAD SPACE ABSENT _____
 DECHLORINATED IN LAB _____
 APPROPRIATE CONTAINERS _____
 PRESERVED IN LAB _____
 COMMENTS:
 VOAS | O&G | METALS | OTHER
 PRESERVATION | pH<2

McC Campbell Analytical, Inc.



1534 Willow Pass Rd
 Pittsburg, CA 94565-1701
 (925) 252-9262

CHAIN-OF-CUSTODY RECORD

WorkOrder: 1303385

ClientCode: CESW

WaterTrax
 WriteOn
 EDF
 Excel
 EQuIS
 Email
 HardCopy
 ThirdParty
 J-flag

Report to:

Tim Cook
 Cook Environmental Services, Inc.
 1485 Treat Blvd, Ste. 203A
 Walnut Creek, CA 94597
 (925) 478-8390 FAX: 925-937-1759

Email: tcook@cookenvironmental.com
 cc:
 PO:
 ProjectNo: #1095; Paoli Construction

Bill to:

Tim Cook
 Cook Environmental Services, Inc.
 1485 Treat Blvd, Ste. 203A
 Walnut Creek, CA 94597

Requested TAT:

5 days

Date Received: 03/13/2013

Date Printed: 03/13/2013

Lab ID	Client ID	Matrix	Collection Date	Hold	Requested Tests (See legend below)												
					1	2	3	4	5	6	7	8	9	10	11	12	
1303385-001	S-1	Soil	3/13/2013	<input type="checkbox"/>	A	A	A										
1303385-002	S-2	Soil	3/13/2013	<input type="checkbox"/>	A	A	A										

Test Legend:

1	8260VOC_S	2	G-MBTEX_S	3	TPH(DMO)_S	4		5	
6		7		8		9		10	
11		12							

Prepared by: Jena Alfaro

Comments:

NOTE: Soil samples are discarded 60 days after results are reported unless other arrangements are made (Water samples are 30 days).
 Hazardous samples will be returned to client or disposed of at client expense.



Sample Receipt Checklist

Client Name: **Cook Environmental Services, Inc.**

Date and Time Received: **3/13/2013 3:28:27 PM**

Project Name: **#1095; Paoli Construction**

LogIn Reviewed by: **Jena Alfaro**

WorkOrder N°: **1303385** Matrix: Soil

Carrier: Rob Pringle (MAI Courier)

Chain of Custody (COC) Information

Chain of custody present?	Yes <input checked="" type="checkbox"/>	No <input type="checkbox"/>
Chain of custody signed when relinquished and received?	Yes <input checked="" type="checkbox"/>	No <input type="checkbox"/>
Chain of custody agrees with sample labels?	Yes <input checked="" type="checkbox"/>	No <input type="checkbox"/>
Sample IDs noted by Client on COC?	Yes <input checked="" type="checkbox"/>	No <input type="checkbox"/>
Date and Time of collection noted by Client on COC?	Yes <input checked="" type="checkbox"/>	No <input type="checkbox"/>
Sampler's name noted on COC?	Yes <input checked="" type="checkbox"/>	No <input type="checkbox"/>

Sample Receipt Information

Custody seals intact on shipping container/cooler?	Yes <input type="checkbox"/>	No <input type="checkbox"/>	NA <input checked="" type="checkbox"/>
Shipping container/cooler in good condition?	Yes <input checked="" type="checkbox"/>	No <input type="checkbox"/>	
Samples in proper containers/bottles?	Yes <input checked="" type="checkbox"/>	No <input type="checkbox"/>	
Sample containers intact?	Yes <input checked="" type="checkbox"/>	No <input type="checkbox"/>	
Sufficient sample volume for indicated test?	Yes <input checked="" type="checkbox"/>	No <input type="checkbox"/>	

Sample Preservation and Hold Time (HT) Information

All samples received within holding time?	Yes <input checked="" type="checkbox"/>	No <input type="checkbox"/>	
Container/Temp Blank temperature	Cooler Temp: 2.8°C		NA <input type="checkbox"/>
Water - VOA vials have zero headspace / no bubbles?	Yes <input type="checkbox"/>	No <input type="checkbox"/>	No VOA vials submitted <input checked="" type="checkbox"/>
Sample labels checked for correct preservation?	Yes <input checked="" type="checkbox"/>	No <input type="checkbox"/>	
Metal - pH acceptable upon receipt (pH<2)?	Yes <input type="checkbox"/>	No <input type="checkbox"/>	NA <input checked="" type="checkbox"/>
Samples Received on Ice?	Yes <input checked="" type="checkbox"/>	No <input type="checkbox"/>	

(Ice Type: WET ICE)

* NOTE: If the "No" box is checked, see comments below.

 Comments:



Cook Environmental Services, Inc. 1485 Treat Blvd, Ste. 203A Walnut Creek, CA 94597	Client Project ID: #1095; Paoli Construction	Date Sampled: 03/13/13
	Client Contact: Tim Cook	Date Received: 03/13/13
	Client P.O.:	Date Extracted 03/13/13
		Date Analyzed 03/14/13

Volatile Organics by P&T and GC/MS*

Extraction method: SW5030B

Analytical methods: SW8260B

Work Order: 1303385

Lab ID	Client ID	Matrix	Naphthalene	DF	% SS	Comments
001A	S-1	S	10	200	87	
002A	S-2	S	14	200	91	

Reporting Limit for DF =1; ND means not detected at or above the reporting limit	W	NA	NA
	S	0.005	mg/Kg

* water and vapor samples and all TCLP & SPLP extracts are reported in µg/L, soil/sludge/solid samples in mg/kg, wipe samples in µg/wipe, product/oil/non-aqueous liquid samples in mg/L.
ND means not detected above the reporting limit/method detection limit; N/A means analyte not applicable to this analysis; %SS = Percent Recovery of Surrogate Standard; DF = Dilution Factor
surrogate diluted out of range or surrogate coelutes with another peak.



Cook Environmental Services, Inc. 1485 Treat Blvd, Ste. 203A Walnut Creek, CA 94597	Client Project ID: #1095; Paoli Construction	Date Sampled: 03/13/13
		Date Received: 03/13/13
	Client Contact: Tim Cook	Date Extracted: 03/13/13
	Client P.O.:	Date Analyzed: 03/14/13-03/15/13

Gasoline Range (C6-C12) Volatile Hydrocarbons as Gasoline with BTEX and MTBE*

Extraction method: SW5030B

Analytical methods: SW8021B/8015Bm

Work Order: 1303385

Lab ID	Client ID	Matrix	TPH(g)	MTBE	Benzene	Toluene	Ethylbenzene	Xylenes	DF	% SS	Comments
001A	S-1	S	---	---	ND<1.0	ND<1.0	ND<1.0	ND<1.0	200	---#	d7
002A	S-2	S	---	---	ND<1.0	ND<1.0	ND<1.0	ND<1.0	200	110	d7

Reporting Limit for DF =1; ND means not detected at or above the reporting limit	W	50	5.0	0.5	0.5	0.5	0.5	0.5	ug/L
	S	1.0	0.05	0.005	0.005	0.005	0.005	0.005	mg/Kg

* water and vapor samples are reported in µg/L, soil/sludge/solid samples in mg/kg, wipe samples in µg/wipe, product/oil/non-aqueous liquid samples and all TCLP & SPLP extracts in mg/L.

cluttered chromatogram; sample peak coelutes w/surrogate peak; low surrogate recovery due to matrix interference; %SS = Percent Recovery of Surrogate Standard; DF = Dilution Factor

The following descriptions of the TPH chromatogram are cursory in nature and McC Campbell Analytical is not responsible for their interpretation:
 d7) strongly aged gasoline or diesel range compounds are significant in the TPH(g) chromatogram



McC Campbell Analytical, Inc.

"When Quality Counts"

1534 Willow Pass Road, Pittsburg, CA 94565-1701
Toll Free Telephone: (877) 252-9262 / Fax: (925) 252-9269
http://www.mccampbell.com / E-mail: main@mccampbell.com

Cook Environmental Services, Inc. 1485 Treat Blvd, Ste. 203A Walnut Creek, CA 94597	Client Project ID: #1095; Paoli Construction	Date Sampled: 03/13/13
	Client Contact: Tim Cook	Date Received: 03/13/13
	Client P.O.:	Date Extracted: 03/13/13
		Date Analyzed: 03/15/13

Total Extractable Petroleum Hydrocarbons*

Extraction method: SW3550B

Analytical methods: SW8015B

Work Order: 1303385

Lab ID	Client ID	Matrix	TPH-Diesel (C10-C23)	TPH-Motor Oil (C18-C36)	DF	% SS	Comments
1303385-001A	S-1	S	11,000	11,000	100	101	e7,e1,e2
1303385-002A	S-2	S	6500	5200	50	102	e1,e7,e2

Reporting Limit for DF =1; ND means not detected at or above the reporting limit	W	NA	NA	ug/L
	S	1.0	5.0	mg/Kg

* water samples are reported in µg/L, wipe samples in µg/wipe, soil/solid/sludge samples in mg/kg, product/oil/non-aqueous liquid samples in mg/L, and all DISTLC / STLC / SPLP / TCLP extracts are reported in µg/L.

cluttered chromatogram resulting in coeluted surrogate and sample peaks, or; surrogate peak is on elevated baseline, or; surrogate has been diminished by dilution of original extract; %SS = Percent Recovery of Surrogate Standard; DF = Dilution Factor

The following descriptions of the TPH chromatogram are cursory in nature and McC Campbell Analytical is not responsible for their interpretation:
e1) unmodified or weakly modified diesel is significant
e2) diesel range compounds are significant; no recognizable pattern
e7) oil range compounds are significant



QC SUMMARY REPORT FOR SW8015B

W.O. Sample Matrix: Soil

QC Matrix: Soil

BatchID: 75463

WorkOrder: 1303385

EPA Method: SW8015B		Extraction: SW3550B					Spiked Sample ID: 1303388-001A			
Analyte	Sample	Spiked	MS	MSD	MS-MSD	LCS	Acceptance Criteria (%)			
	mg/Kg	mg/Kg	% Rec.	% Rec.	% RPD	% Rec.	MS / MSD	RPD	LCS	
TPH-Diesel (C10-C23)	11	40	NR	NR	NR	98	N/A	N/A	70 - 130	
%SS:	82	25	NR	NR	NR	93	N/A	N/A	70 - 130	

All target compounds in the Method Blank of this extraction batch were ND less than the method RL with the following exceptions:
 NONE

BATCH 75463 SUMMARY

Lab ID	Date Sampled	Date Extracted	Date Analyzed	Lab ID	Date Sampled	Date Extracted	Date Analyzed
1303385-001A	03/13/13	03/13/13	03/15/13 9:17 PM	1303385-002A	03/13/13	03/13/13	03/15/13 11:35 PM

MS = Matrix Spike; MSD = Matrix Spike Duplicate; LCS = Laboratory Control Sample; LCSD = Laboratory Control Sample Duplicate; RPD = Relative Percent Deviation.
 $\% \text{ Recovery} = 100 * (\text{MS-Sample}) / (\text{Amount Spiked}); \text{RPD} = 100 * (\text{MS} - \text{MSD}) / ((\text{MS} + \text{MSD}) / 2).$
 MS / MSD spike recoveries and / or %RPD may fall outside of laboratory acceptance criteria due to one or more of the following reasons: a) the sample is inhomogenous AND contains significant concentrations of analyte relative to the amount spiked, or b) the spiked sample's matrix interferes with the spike recovery.
 N/A = not enough sample to perform matrix spike and matrix spike duplicate.
 NR = analyte concentration in sample exceeds spike amount for soil matrix or exceeds 2x spike amount for water matrix or sample diluted due to high matrix or analyte content.



QC SUMMARY REPORT FOR SW8260B

W.O. Sample Matrix: Soil

QC Matrix: Soil

BatchID: 75471

WorkOrder: 1303385

Analyte	EPA Method: SW8260B		Extraction: SW5030B				Spiked Sample ID: 1303385-001A			
	Sample	Spiked	MS	MSD	MS-MSD	LCS	Acceptance Criteria (%)			
	mg/Kg	mg/Kg	% Rec.	% Rec.	% RPD	% Rec.	MS / MSD	RPD	LCS	
tert-Amyl methyl ether (TAME)	ND<1	0.050	NR	NR	NR	90.8	N/A	N/A	70 - 130	
Benzene	ND<1	0.050	NR	NR	NR	95.4	N/A	N/A	70 - 130	
t-Butyl alcohol (TBA)	ND<10	0.20	NR	NR	NR	112	N/A	N/A	70 - 130	
Chlorobenzene	ND<1	0.050	NR	NR	NR	95.4	N/A	N/A	70 - 130	
1,2-Dibromoethane (EDB)	ND<0.8	0.050	NR	NR	NR	101	N/A	N/A	70 - 130	
1,2-Dichloroethane (1,2-DCA)	ND<0.8	0.050	NR	NR	NR	101	N/A	N/A	70 - 130	
Diisopropyl ether (DIPE)	ND<1	0.050	NR	NR	NR	99.2	N/A	N/A	70 - 130	
Ethyl tert-butyl ether (ETBE)	ND<1	0.050	NR	NR	NR	99.5	N/A	N/A	70 - 130	
Methyl-t-butyl ether (MTBE)	ND<1	0.050	NR	NR	NR	99.5	N/A	N/A	70 - 130	
Toluene	ND<1	0.050	NR	NR	NR	104	N/A	N/A	70 - 130	
Trichloroethene	ND<1	0.050	NR	NR	NR	93	N/A	N/A	70 - 130	
%SS1:	99	0.12	NR	NR	NR	97	N/A	N/A	70 - 130	
%SS2:	107	0.12	NR	NR	NR	115	N/A	N/A	70 - 130	
%SS3:	87	0.012	NR	NR	NR	112	N/A	N/A	70 - 130	

All target compounds in the Method Blank of this extraction batch were ND less than the method RL with the following exceptions:
 NONE

BATCH 75471 SUMMARY

Lab ID	Date Sampled	Date Extracted	Date Analyzed	Lab ID	Date Sampled	Date Extracted	Date Analyzed
1303385-001A	03/13/13	03/13/13	03/14/13 1:22 AM	1303385-002A	03/13/13	03/13/13	03/14/13 2:04 AM

MS = Matrix Spike; MSD = Matrix Spike Duplicate; LCS = Laboratory Control Sample; LCS D = Laboratory Control Sample Duplicate; RPD = Relative Percent Deviation.
 % Recovery = 100 * (MS-Sample) / (Amount Spiked); RPD = 100 * (MS - MSD) / ((MS + MSD) / 2).
 * MS and / or MSD spike recoveries may not be near 100% or the RPDs near 0% if: a) the sample is inhomogenous AND contains significant concentrations of analyte relative to the amount spiked, or b) if that specific sample matrix interferes with spike recovery.
 N/A = not enough sample to perform matrix spike and matrix spike duplicate.
 NR = analyte concentration in sample exceeds spike amount for soil matrix or exceeds 2x spike amount for water matrix or sample diluted due to high matrix or analyte content.
 Laboratory extraction solvents such as methylene chloride and acetone may occasionally appear in the method blank at low levels.



QC SUMMARY REPORT FOR SW8021B/8015Bm

W.O. Sample Matrix: Soil

QC Matrix: Soil

BatchID: 75465

WorkOrder: 1303385

EPA Method: SW8021B/8015Bm		Extraction: SW5030B					Spiked Sample ID: 1303387-002A			
Analyte	Sample	Spiked	MS	MSD	MS-MSD	LCS	Acceptance Criteria (%)			
	mg/Kg	mg/Kg	% Rec.	% Rec.	% RPD	% Rec.	MS / MSD	RPD	LCS	
TPH(btex) £	ND	0.60	95.9	101	5.38	99.2	70 - 130	20	70 - 130	
MTBE	ND	0.10	74.2	81.5	8.79	76.6	70 - 130	20	70 - 130	
Benzene	ND	0.10	98.8	104	4.90	98.2	70 - 130	20	70 - 130	
Toluene	ND	0.10	95.8	100	4.13	96.2	70 - 130	20	70 - 130	
Ethylbenzene	ND	0.10	97.9	101	2.91	96.2	70 - 130	20	70 - 130	
Xylenes	ND	0.30	98	101	3.25	97.4	70 - 130	20	70 - 130	
%SS:	110	0.10	79	83	5.12	100	70 - 130	20	70 - 130	

All target compounds in the Method Blank of this extraction batch were ND less than the method RL with the following exceptions:
 NONE

BATCH 75465 SUMMARY

Lab ID	Date Sampled	Date Extracted	Date Analyzed	Lab ID	Date Sampled	Date Extracted	Date Analyzed
1303385-001A	03/13/13	03/13/13	03/14/13 6:06 AM	1303385-002A	03/13/13	03/13/13	03/15/13 3:18 AM

MS = Matrix Spike; MSD = Matrix Spike Duplicate; LCS = Laboratory Control Sample; LCSD = Laboratory Control Sample Duplicate; RPD = Relative Percent Deviation.
 % Recovery = 100 * (MS-Sample) / (Amount Spiked); RPD = 100 * (MS - MSD) / ((MS + MSD) / 2).
 MS / MSD spike recoveries and / or %RPD may fall outside of laboratory acceptance criteria due to one or more of the following reasons: a) the sample is inhomogenous AND contains significant concentrations of analyte relative to the amount spiked, or b) the spiked sample's matrix interferes with the spike recovery.
 £ TPH(btex) = sum of BTEX areas from the FID.
 # cluttered chromatogram; sample peak coelutes with surrogate peak.
 N/A = not enough sample to perform matrix spike and matrix spike duplicate.
 NR = matrix interference and/or analyte concentration in sample exceeds spike amount for soil matrix or exceeds 2x spike amount for water matrix or sample diluted due to high matrix or analyte content.

APPENDIX C
Special Waste Profiles for
Non-Hazardous Soil

Potrero Hills Landfill
 3675 Potrero Hills Lane
 Suisun, CA 94585
 Phone: 707.432.4622
 Fax: 707.426.5013



WASTE CONNECTIONS INC.
Connect with the Future™

FOR OFFICE USE ONLY

APPROVAL NUMBER:

EXPIRATION DATE:

APPROVED BY:

SPECIAL WASTE PROFILE

Information utilized for completion of this form must originate from an authorized representative of the generator of the waste material. The information on this form must be **COMPLETELY FILLED OUT, TYPE WRITTEN**, and the form must be **SIGNED BY AUTHORIZED REPRESENTATIVE**.

A. GENERATOR INFORMATION		B. CUSTOMER/BILLING INFORMATION	
1. Generator Name: Susan Casentini Trust		1. Billing Name: Fremouw Environmental Services, Inc	
2. Address: 385 26th St.		2. Address: PO Box 2875 / 6940 Tremont Road	
City: Oakland	County:	City: Vacaville / Dixon	County:
State: CA	Zip: 94901	State: CA	Zip: 9569695620
3. Site Location (if different):		3. Contact Name: Dina Barron	
4. Contact Name: Susan Casentini Trust		4. Phone Number: 707-448-3700	5. Fax Number: 707-448-3499
5. Phone Number: 925-478-8390	6. Fax Number: - -	6. Email Address: dbarron@hazwasteremoval.com	
7. Email Address:		7. Is there a service agreement on file? <input checked="" type="checkbox"/> YES <input type="checkbox"/> NO	
8. State Facility ID # (if applicable):		8. Agent / Consultant: Joe Lynch	
9. State Waste Code (if applicable):		9. Letter of Authorization: <input type="checkbox"/> YES <input type="checkbox"/> NO	
C. TRANSPORTER/SHIPPING INFORMATION		D. WASTE STREAM INFORMATION	
1. Name: Fremouw Environmental Services, Inc		1. Common Name of Material or Waste Stream: Non Haz Soil for Burial	
2. Street Address: 6940 Tremont Road		2. Detailed Description of Process or How Generated (Attach additional sheet if needed): Site Clean-up	
City: Dixon	State: CA	Zip: 95620	
3. Phone Number: 707-448-3700	4. Fax Number: 707-448-3499	3. Physical State at 70°F: <input checked="" type="checkbox"/> Solid <input type="checkbox"/> Semi-Solid <input type="checkbox"/> Sludge <input type="checkbox"/> Liquid <input type="checkbox"/> Powder <input type="checkbox"/> Other _____	
5. Contact Name: Dina		4. Free Liquids: <input checked="" type="checkbox"/> NO <input type="checkbox"/> YES % Liquids	
6. EPA or State Transporter ID #: CAR 000 171 017		5. Color: varies	
7. Designated Landfill(s): Potrero Hills		6. pH Range: 4 -10	
8. Packaging: <input checked="" type="checkbox"/> Bulk Solids <input type="checkbox"/> Bulk Liquids <input type="checkbox"/> Drums <input type="checkbox"/> Roll-Off <input type="checkbox"/> Dump Truck <input type="checkbox"/> Tank Truck <input type="checkbox"/> Vacuum Box <input type="checkbox"/> Bagged		7. Odor: <input type="checkbox"/> None <input checked="" type="checkbox"/> Mild <input type="checkbox"/> Significant Describe:	
9. Estimated Volume: 30 <input checked="" type="checkbox"/> Tons <input checked="" type="checkbox"/> Cubic Yards <input type="checkbox"/> Drums <input type="checkbox"/> Gallons <input type="checkbox"/> Other: _____		8. Flash Point: N/A <input type="checkbox"/> °F <input type="checkbox"/> °C	
10. Shipping Frequency: _____ per <input type="checkbox"/> One Time Project <input type="checkbox"/> Month <input checked="" type="checkbox"/> Quarter <input type="checkbox"/> Year <input type="checkbox"/> Other: _____		9. Reactive: <input checked="" type="checkbox"/> NO <input type="checkbox"/> YES with	
		10. State Required Information (if applicable):	
E. NON-HAZARDOUS DETERMINATION			
1. Attached Document(s) (check all that apply): <input type="checkbox"/> Not Applicable <input type="checkbox"/> MSDS <input checked="" type="checkbox"/> Certified Analytical Report <input type="checkbox"/> Process Knowledge			
2. If Process Knowledge, provide details:			
3. If analytical data is attached, is the data derived from testing a representative sample in accordance with 40 CFR 261 and/or other applicable laws? <input checked="" type="checkbox"/> YES <input type="checkbox"/> NO Type of Sample: <input type="checkbox"/> Composite <input type="checkbox"/> Grab			
F. CERTIFICATION INFORMATION			
1. <input type="checkbox"/> Initial <input type="checkbox"/> Recertification, list prior approval number(s): <input type="checkbox"/> Amendment, Details:			
2. Have there been any changes to the composition of, or process generating this waste stream that would alter the characteristics of the waste stream? <input type="checkbox"/> YES <input type="checkbox"/> NO (Updated analysis may be required.)			
G. WASTE CERTIFICATION STATEMENT:			
I hereby certify that all information contained herein is true and correct, and the material described is properly identified, classified, packaged, labeled, and prepared as indicated. I certify this waste is not hazardous or dangerous as defined by the U.S. EPA, or the state or province of origin. I certify this waste does not contain any regulated radioactive materials, that all known and suspected hazards have been disclosed, and that the waste is not a regulated hazardous waste by government or local authority, and does not contain PCB's regulated by TSCA or any other regulatory authority. I certify that all samples used for this analysis are representative of the materials described herein. I understand that all wastes may undergo inspection upon arrival at the designated facility and may be refused if the delivered material does not conform to the description herein. Notification will be provided immediately if there is a change in the composition of, or process generating this waste stream, prior to offering the waste for shipment or management.			
AUTHORIZED REPRESENTATIVE NAME/TITLE		COMPANY NAME	
AUTHORIZED REPRESENTATIVE SIGNATURE		DATE COMPLETED	

Potrero Hills Landfill
 3675 Potrero Hills Lane
 Suisun, CA 94585
 Phone: 707.432.4622
 Fax: 707.426.5013



WASTE CONNECTIONS INC.
Connect with the Future™

FOR OFFICE USE ONLY

APPROVAL NUMBER:

EXPIRATION DATE:

APPROVED BY:

SPECIAL WASTE PROFILE

Information utilized for completion of this form must originate from an authorized representative of the generator of the waste material. The information on this form must be **COMPLETELY FILLED OUT, TYPE WRITTEN**, and the form must be **SIGNED BY AUTHORIZED REPRESENTATIVE**.

A. GENERATOR INFORMATION		B. CUSTOMER/BILLING INFORMATION	
1. Generator Name: Susan Casentini Trust		1. Billing Name: Fremouw Environmental Services, Inc	
2. Address: 385 26 th St.		2. Address: PO Box 2875 / 6940 Tremont Road	
City: Oakland	County:	City: Vacaville / Dixon	County:
State: CA	Zip: 94901	State: CA	Zip: 9569695620
3. Site Location (if different):		3. Contact Name: Dina Barron	
4. Contact Name: Susan Casentini Trust		4. Phone Number: 707-448-3700	5. Fax Number: 707-448-3499
5. Phone Number: 925-478-8390	6. Fax Number: - -	6. Email Address: dbarron@hazwasteremoval.com	
7. Email Address:		7. Is there a service agreement on file? <input checked="" type="checkbox"/> YES <input type="checkbox"/> NO	
8. State Facility ID # (if applicable):		8. Agent / Consultant: Joe Lynch	
9. State Waste Code (if applicable):		9. Letter of Authorization: <input type="checkbox"/> YES <input type="checkbox"/> NO	
C. TRANSPORTER/SHIPPING INFORMATION		D. WASTE STREAM INFORMATION	
1. Name: Fremouw Environmental Services, Inc		1. Common Name of Material or Waste Stream: Non Haz Soil containing debris for Burial	
2. Street Address: 6940 Tremont Road		2. Detailed Description of Process or How Generated (Attach additional sheet if needed): Site Clean-up	
City: Dixon	State: CA	Zip: 95620	
3. Phone Number: 707-448-3700	4. Fax Number: 707-448-3499		
5. Contact Name: Dina		3. Physical State at 70°F: <input checked="" type="checkbox"/> Solid <input type="checkbox"/> Semi-Solid <input type="checkbox"/> Sludge <input type="checkbox"/> Liquid <input type="checkbox"/> Powder <input type="checkbox"/> Other _____	
6. EPA or State Transporter ID #: CAR 000 171 017		4. Free Liquids: <input checked="" type="checkbox"/> NO <input type="checkbox"/> YES % Liquids	
7. Designated Landfill(s): Potrero Hills		5. Color: varies	
8. Packaging: <input checked="" type="checkbox"/> Bulk Solids <input type="checkbox"/> Bulk Liquids <input type="checkbox"/> Drums <input type="checkbox"/> Roll-Off <input type="checkbox"/> Dump Truck <input type="checkbox"/> Tank Truck <input type="checkbox"/> Vacuum Box <input type="checkbox"/> Bagged		6. pH Range: 4 -10	
9. Estimated Volume: 10 <input checked="" type="checkbox"/> Tons <input checked="" type="checkbox"/> Cubic Yards <input type="checkbox"/> Drums <input type="checkbox"/> Gallons <input type="checkbox"/> Other: _____		7. Odor: <input type="checkbox"/> None <input checked="" type="checkbox"/> Mild <input type="checkbox"/> Significant Describe:	
10. Shipping Frequency: _____ per <input type="checkbox"/> One Time Project <input type="checkbox"/> Month <input checked="" type="checkbox"/> Quarter <input type="checkbox"/> Year <input type="checkbox"/> Other: _____		8. Flash Point: N/A <input type="checkbox"/> °F <input type="checkbox"/> °C	
		9. Reactive: <input checked="" type="checkbox"/> NO <input type="checkbox"/> YES with	
		10. State Required Information (if applicable):	
E. NON-HAZARDOUS DETERMINATION			
1. Attached Document(s) (check all that apply): <input type="checkbox"/> Not Applicable <input type="checkbox"/> MSDS <input checked="" type="checkbox"/> Certified Analytical Report <input type="checkbox"/> Process Knowledge			
2. If Process Knowledge, provide details:			
3. If analytical data is attached, is the data derived from testing a representative sample in accordance with 40 CFR 261 and/or other applicable laws? <input checked="" type="checkbox"/> YES <input type="checkbox"/> NO Type of Sample: <input type="checkbox"/> Composite <input type="checkbox"/> Grab			
F. CERTIFICATION INFORMATION			
1. <input type="checkbox"/> Initial <input type="checkbox"/> Recertification, list prior approval number(s): _____ <input type="checkbox"/> Amendment, Details:			
2. Have there been any changes to the composition of, or process generating this waste stream that would alter the characteristics of the waste stream? <input type="checkbox"/> YES <input type="checkbox"/> NO (Updated analysis may be required.)			
G. WASTE CERTIFICATION STATEMENT:			
I hereby certify that all information contained herein is true and correct, and the material described is properly identified, classified, packaged, labeled, and prepared as indicated. I certify this waste is not hazardous or dangerous as defined by the U.S. EPA, or the state or province of origin. I certify this waste does not contain any regulated radioactive materials, that all known and suspected hazards have been disclosed, and that the waste is not a regulated hazardous waste by government or local authority, and does not contain PCB's regulated by TSCA or any other regulatory authority. I certify that all samples used for this analysis are representative of the materials described herein. I understand that all wastes may undergo inspection upon arrival at the designated facility and may be refused if the delivered material does not conform to the description herein. Notification will be provided immediately if there is a change in the composition of, or process generating this waste stream, prior to offering the waste for shipment or management.			
AUTHORIZED REPRESENTATIVE NAME/TITLE		COMPANY NAME	
AUTHORIZED REPRESENTATIVE SIGNATURE		DATE COMPLETED	

APPENDIX D

Waste Manifests for Non-Hazardous Soil

NON-HAZARDOUS WASTE MANIFEST 1. Gene

5. Generator's Name and Mailing Address:
SUSAN CASENTINI TR
385 26TH STREET
OAKLAND CA 94901
 Generator's Phone: **925**
 6. Transporter 1 Company Name:
FREMOW ENVIRO
 7. Transporter 2 Company Name:

8. Designated Facility Name and Site Address:
POTRERO HILLS LAND
3675 POTRERO HILLS
SUISUN CA 94585
 Facility's Phone: **707 432-462**

9. Waste Shipping Name and Description:
1. NON HAZARDOUS

1.	NON HAZARDOUS
2.	
3.	
4.	

13. Special Handling Instructions and Additional Information:
Bin # J616

POTRERO HILLS LANDFILL, INC.
 Weighed at:
 POTRERO HILLS LANDFILL, INC.
 P.O. Box 68
 FAIRFIELD, CA 94533
 Deputy: Janee Quinonez
 Deposit: Janee Quinonez
 BILL TO: 2623
 FREMOW ENVIRONMENTAL SERVICES

Vehicle ID:
 Reference: PHLF13075
 Grid: 14
 HaulCust#: DRIGIN-OAKLAND
 DriverOn?: N
 Route: 031213MFA BIN J616
 TRLR/LP#: 17030D1
 Origin: OAKLAND
 DATE IN: 03/20/2013 TIME IN: 12:58:37
 DATE OUT: 03/20/2013 TIME OUT: 13:18:15
 INBOUND TICKET Number: 01-356019

SCALE 1 GROSS WT. 44520 LB
 SCALE 3 TARE WT. 27360 LB
 NET WEIGHT 17160 LB

Qty	Description	Amount
8.58	Profile Soil-T Disp	

None
 4. Waste Tracking Number
EMFREC 031213MFB16
 (different than mailing address)

U.S. EPA ID Number
CAR000171017
 U.S. EPA ID Number
 U.S. EPA ID Number

type	11. Total Quantity	12. Unit Wt./Vol.	
n	13	Y	NONE

HANDLERS TO BE 40HR TRAINED AND USE PPE.

14. GENERATOR'S/OFFEROR'S CERTIFICATION: I hereby declare that the contents of this consignment are fully and accurately described above by the proper shipping name, and are classified, packaged, marked and labeled/placarded, and are in all respects in proper condition for transport according to applicable international and national governmental regulations.

Generator's/Officer's Printed/Typed Name: **X K. L. MULLISAN & SUSAN CASENTINI TRUST** Signature: **X Tom Col Asst of Gen...** Month: **03** Day: **12** Year: **13**

15. International Shipments: Import to U.S. Export from U.S. Port of entry/exit: Date leaving U.S.:

16. Transporter Acknowledgment of Receipt of Materials: Transporter Signature (for exports only): **PATRICK RAPORA** Signature: **PATR** Month: **03** Day: **12** Year: **13**

17. Discrepancy: 17a. Discrepancy Indication Space: Quantity Type Residue Partial Rejection Full Rejection. Manifest Reference Number: U.S. EPA ID Number:

17b. Alternate Facility (or Generator): Facility's Phone: 17c. Signature of Alternate Facility (or Generator): Month: Day: Year:

18. Designated Facility Owner or Operator: Certification of receipt of materials covered by the manifest except as noted in item 17a: Printed/Typed Name: Signature: Month: Day: Year:

POTRERO HILLS LANDFILL, INC.
 Weighed at:
 POTRERO HILLS LANDFILL, INC.
 P.O. Box 68
 FAIRFIELD, CA 94533

NON-HAZARDOUS WASTE MANIFEST 1. Generator

5. Generator's Name and Mailing Address
SUSAN CASENTINI TRUJ
385 26TH STREET
OAKLAND CA 94901

Generator's Phone: **9 2 5** 4

6. Transporter 1 Company Name
FREMOW ENVIRONN

7. Transporter 2 Company Name

8. Designated Facility Name and Site Address
POTRERO HILLS LANDFI
3675 POTRERO HILLS LA
SUISUN CA 94585

Facility's Phone: **707 432-4627**

Deputy: Jaclyn Deleon
 Deposit: Jaclyn Deleon
 BILL TO: 2623
 FREMOW ENVIRONMENTAL SERVICES

9. Waste Shipping Name and Description

1. **NON HAZARDOUS SO**

2.

3.

4.

Vehicle ID: DD1
 Reference: PHLF13075
 Grid: 14
 HaulCust#: ORIGIN-OAKLAND
 DriverOn?: N
 Route: 031313MF31
 TRLR/LP#: BINS R27963PL & R23768PL

Origin: OAKLAND
 DATE IN: 03/25/2013 TIME IN: 12:52:46
 DATE OUT: 03/25/2013 TIME OUT: 13:45:51

INBOUND TICKET Number: 01-35703B

SCALE 1 GROSS WT. 78780 LB
 SCALE 3 TARE WT. 40420 LB
 NET WEIGHT 38360 LB

13. Special Handling Instructions and Additional In

19.18 Profile Soil-T Disp

Bin #'s R27963PL

HANDLERS TO BE 40HR TRAINED AND USE PPE.

14. GENERATOR'S/OFFEROR'S CERTIFICATION: I hereby declare that the contents of this consignment are fully and accurately described above by the proper shipping name, and are classified, packaged, marked and labeled/placarded, and are in all respects in proper condition for transport according to applicable international and national governmental regulations.

Generator's/Officer's Printed/Typed Name: **X Kyle Miller** Signature: **[Signature]** Month: **03** Day: **13** Year: **13**

Generator's/Officer's Printed/Typed Name: **SUSAN CASENTINI TRUJ** Signature: **[Signature]** Month: **03** Day: **13** Year: **13**

15. International Shipments: Import to U.S. Export from U.S. Port of entry/exit: Date leaving U.S.:

Transporter Signature (for exports only):

16. Transporter Acknowledgment of Receipt of Materials

Transporter 1 Printed/Typed Name: **PATRICK RAPPO** Signature: **[Signature]** Month: **03** Day: **13** Year: **13**

Transporter 2 Printed/Typed Name: Signature: Month: Day: Year:

17. Discrepancy

17a. Discrepancy Indication Spec: Quantity Type Residue Partial Rejection Full Rejection

Manifest Reference Number: U.S. EPA ID Number:

17b. Alternate Facility (or Generator) U.S. EPA ID Number:

Facility's Phone:

17c. Signature of Alternate Facility (or Generator) Month: Day: Year:

18. Designated Facility Owner or Operator: Certification of receipt of materials covered by the manifest except as noted in item 17a

Printed/Typed Name: Signature: Month: Day: Year:

DUPLICATE TICKET

POTRERO HILLS LANDFILL, INC.
Weighed at:
POTRERO HILLS LANDFILL, INC.
P.O. Box 68
FAIRFIELD, CA 94533

Deputy: Janea Quinonez
Deposit: Janea Quinonez
BILL TO: 2623
PREMOU ENVIRONMENTAL SERVICES

Vehicle ID:
Reference: PHLF13076
Grid: 14
HaulCust#: ORIGIN-OAKLAND
DriverOn?: N
TRLR/LP#: 10703D1

Origin: OAKLAND
DATE IN: 03/20/2013 TIME IN: 13:32:29
DATE OUT: 03/20/2013 TIME OUT: 13:54:00

INBOUND TICKET Number: 01-356028

SCALE 1 GROSS WT. 44840 LB
SCALE 3 TARE WT. 27360 LB
NET WEIGHT 17480 LB

Qty Description Amount
8.74 Profile Soil-T Disp

4. Waste Tracking Number
031213MF31A
(mailing address)

U.S. EPA ID Number
CAR000171017

U.S. EPA ID Number

U.S. EPA ID Number

11. Total Quantity	12. Unit Wt./Vol.	
12	Y	NONE

typical provided to disposal facility)

HANDLERS TO BE 40HR. TRAINED AND USE PPE.

NON-HAZARDOUS WASTE MANIFEST

1. Generator ID Number

5. Generator's Name and Mailing Address
SUSAN CASENTINI TRUST
385 26TH STREET
OAKLAND CA 94901
Generator's Phone: 925 478

6. Transporter 1 Company Name
PREMOU ENVIRONMEN

7. Transporter 2 Company Name

8. Designated Facility Name and Site Address
POTRERO HILLS LANDFILL,
3675 POTRERO HILLS LANE
SUISUN CA 94585
Facility's Phone: 707 432-4627

9. Waste Shipping Name and Description
1. **NON-HAZARDOUS SOLID**

2.

3.

4.

13. Special Handling Instructions and Additional Info

SIN# JC 23

Y1M19-14

14. GENERATOR'S/OFFEROR'S CERTIFICATION: I hereby declare that the contents of this consignment are fully and accurately described above by the proper shipping name, and are classified, packaged, marked and labeled/placarded, and are in all respects in proper condition for transport according to applicable international and national governmental regulations.

Generator's/Officer's Printed/Typed Name: **X Kyle Milligan & Susan Casentini Trust** Signature: **X Tim Calahan** Month: 03 Day: 12 Year: 13

15. International Shipments Import to U.S. Export from U.S. Port of entry/exit: Date leaving U.S.:

16. Transporter Acknowledgment of Receipt of Materials
Transporter 1 Printed/Typed Name: **Patrick Raposo** Signature: **Patrick Raposo** Month: 03 Day: 12 Year: 13

Transporter 2 Printed/Typed Name: Signature: Month: Day: Year:

17. Discrepancy
17a. Discrepancy Indication Space Quantity Type Residue Partial Rejection Full Rejection

17b. Alternate Facility (or Generator) Manifest Reference Number: U.S. EPA ID Number:

17c. Signature of Alternate Facility (or Generator) Facility's Phone: Month: Day: Year:

18. Designated Facility Owner or Operator: Certification of receipt of materials covered by the manifest except as noted in item 17a
Printed/Typed Name: **JCE** Signature: **[Signature]** Month: Day: Year: **13 03 13**

DESIGNATED FACILITY TO GENERATOR

APPENDIX E
Special Waste Profile for
Non-RCRA Hazardous Soil



US Ecology Nevada (Beatty) US Ecology Texas (Robstown)
 Fax (775) 553-2125 Fax (361) 387-0794
 US Ecology Idaho (Grand View)
 Fax (208) 834-2919

Profile #: _____

A. CUSTOMER INFORMATION

*Waste as shipped will be: Industrial NON - Industrial *(Texas customers only)

Generator: Tim Cook Check if Billing is Same

Facility Address: 385 26th Street Billing Company: Fremouw Environmental Services, Inc
 (No PO Box) Oakland, CA 94612

Mailing Address: 1485 Treat Blvd, ste 230A Billing Address: 6940 Tremont Road
 City/State/Zip: Walnut Creek, CA 94597 City/State/Zip: Dixon, CA 95620

Technical Contact: Tim Cook Billing Contact: Accts Payables
 Phone: 925-478-8390 Fax: N/A Phone No.: 707-448-3700 Fax No.: 707-448-3499
 Email: prapozo@hazwasteremoval.com

NAICS# _____ CESQG SQG LQG EPA ID: CAC 002 722 810 State ID# _____

B. SHIPPING INFORMATION

1. US DOT Shipping Name: Non RCRA Hazardous Waste Solid 2. Hazard Class: Non RCRA

3. UN/NA #: Non RCRA 4. Packaging Group: Non RCRA 5. RQ: Non RCRA

6. Container Type: Bulk Totes Pallet Size: 20 Yard Bin 7. Frequency: Year QTR Month
 Boxes Bags Drums Other Quantity: 1 - 2 1 Time Other As needed

C. GENERAL MATERIAL & REGULATORY INFORMATION

1. Common name for this waste: Slty Debris

2. Process generating the material: Hazardous Waste Disposal from various clean up activities
 (include additional sheets as necessary)

3. Describe Physical Appearance of Waste: Slty Debris

4. Describe odor of waste: None Slight Strong Describe: Hydrocarbons

5. Knowledge is from: Lab Analysis MSDS Process/Generator knowledge Other (specify) _____

Yes No Is the material <500 PPMW VOC as generated Yes No Is the waste restricted under EPA Land Disposal Restrictions

Yes No Waste Subject to Benzene NESHAP regulations (40 CFR 268), if yes please complete LDR form

Yes No State waste codes: 223 Wastewater Non-wastewater Debris

Yes No CERCLA Regulated (Superfund) Waste Yes No Exempt Waste: If yes, list ref. 40 CFR _____

Yes No EPA Haz. Waste (list codes) Yes No Contains UHCs/Constituents of Concern: List in section D _____

Yes No Has the waste been treated after the initial point of generation? Yes No Subpart XX ¹⁵ _____

Yes No Alternative standards for Soil? Yes No _____

Source Code G: G11 Form Code W: W316 Mgt. Method H: _____

D. MATERIAL COMPOSITION (Physical/Chemical)

(Range Total > or = 100%) Values are TCLP TOTALS

(include additional sheets as necessary) typical value unit range

Oil contaminated Soil	95-100	%	0-100%
Oil contaminated Wood	1-10	%	0-100%
Oil contaminated Steel Banding	0-1	%	0-100%
Hose	1-2	%	0-100%

E. Does the waste exhibit or contain the following:

Yes No Oxidizer Yes No React. Sulfides _____ ppm

Yes No Explosive Yes No React. Cyanides _____ ppm

Yes No Organic Peroxide Yes No Water/Air (Pyrophoric) React.

Yes No Shock Sensitive Yes No Thermally Unstable

Yes No Tires Yes No TSCA Regulated PCB Waste

Yes No Pyrophoric Yes No Regulated Medical/Infectious Waste

Yes No Radioactive** Yes No Compressed Gasses

Yes No Exempt RAD** ****Additional Radiological info is provided in USEI's WAC Addendum**

Yes No Halogenated Organic Compounds? (per 40 CFR 268, Appendix III)

F. PHYSICAL CHARACTERISTICS

1. Flash Point: Solid Waste °F (if <140°F) 2. Typical pH: Solid Waste pH Range: ≤ 2
 Yes No Possibility of incidental liquids from transportation? >2, <12.50
 Yes No Does waste pass the EPA specified paint filter test? ≥ 12.5

G. GENERATOR'S CERTIFICATION:

Yes No I certify this material may be disposed of without further treatment.

Certification Statement: I certify under penalty of law that I am familiar with this waste stream through analysis and/or process knowledge, and that all information provided is true, accurate, representative and complete, and that all known or suspected hazards have been disclosed. Furthermore, I certify that this form was completed in accordance with the instructions provided.

Signature: Tim Cook

Print Name: Tim Cook

Title: Asst of S. Cassotini

Date: 3/8/13

Facility use only:

First review: _____ Second review: _____ Final review: _____

Date approved: _____ Date Denied: _____

APPENDIX F
Waste Manifest for
Non-RCRA Hazardous Soil

1095

Please print or type. (Form designed for use on elite (12-pitch) typewriter.)

Form Approved. OMB No. 2050-0039

UNIFORM HAZARDOUS WASTE MANIFEST		1. Generator ID Number CAG002722810	2. Page 1 of 1	3. Emergency Response Phone 800 424-9300 CHEMIFEC	4. Manifest Tracking Number 010189064 JJK			
5. Generator's Name and Mailing Address TIM COOK 1485 TRENT BLVD STE 203A LUALABUT CREEK CA 94597				Generator's Site Address (if different than mailing address) TIM COOK 395 26TH STREET OAKLAND CA 94601				
Generator's Phone: 925-478-9390								
6. Transporter 1 Company Name FREMOUW ENVIRONMENTAL SERVICES INC					U.S. EPA ID Number CAR000171017			
7. Transporter 2 Company Name ENVIRONMENTAL INTERNATIONAL PJFES					U.S. EPA ID Number CAR000178382			
8. Designated Facility Name and Site Address US ECOLOGY INC HWY 95 11MI S OF CY 16 ACRES BEATTY NV 89003					U.S. EPA ID Number NVT330010000			
Facility's Phone: 775 553-2203								
9a. HM	9b. U.S. DOT Description (including Proper Shipping Name, Hazard Class, ID Number, and Packing Group (if any))	10. Containers		11. Total Quantity	12. Unit Wt./Vol.	13. Waste Codes		
		No.	Type					
1.	NON-RCRA HAZARDOUS WASTE, SOLID (OIL DEBRIS, ABSORBENT) (Oil Contaminated Soil) <i>PJFES</i>	2	CM EM	30 80	5 PJFES PY	223		
2.								
3.								
4.								
14. Special Handling Instructions and Additional Information 14070202359-0 - City Debris ERG#171 Oil Contaminated Soil ERG#171 BIN # 993 HANDLERS TO BE 40HR TRAINED AND USE PPE.								
15. GENERATOR'S/OFFEROR'S CERTIFICATION: I hereby declare that the contents of this consignment are fully and accurately described above by the proper shipping name, and are classified, packaged, marked and labeled/placarded, and are in all respects in proper condition for transport according to applicable international and national governmental regulations. If export shipment and I am the Primary Exporter, I certify that the contents of this consignment conform to the terms of the attached EPA Acknowledgment of Consent. I certify that the waste minimization statement identified in 40 CFR 262.27(a) (if I am a large quantity generator) or (b) (if I am a small quantity generator) is true.								
Generator's/Offeror's Printed/Typed Name X Tim Cook Agent of Susan Casarini Trust				Signature <i>[Signature]</i>		Month 03	Day 11	Year 13
16. International Shipments <input type="checkbox"/> Import to U.S. <input type="checkbox"/> Export from U.S. Port of entry/exit: _____ Date leaving U.S.: _____								
17. Transporter Acknowledgment of Receipt of Materials								
Transporter 1 Printed/Typed Name Patrick Jordan				Signature <i>[Signature]</i>		Month 03	Day 11	Year 13
Transporter 2 Printed/Typed Name				Signature		Month	Day	Year
18. Discrepancy								
18a. Discrepancy Indication Space <input type="checkbox"/> Quantity <input type="checkbox"/> Type <input type="checkbox"/> Residue <input type="checkbox"/> Partial Rejection <input type="checkbox"/> Full Rejection								
18b. Alternate Facility (or Generator) Manifest Reference Number: _____ U.S. EPA ID Number _____								
Facility's Phone: _____								
18c. Signature of Alternate Facility (or Generator)						Month	Day	Year
19. Hazardous Waste Report Management Method Codes (i.e., codes for hazardous waste treatment, disposal, and recycling systems)								
1. H1B2		2.		3.		4.		
20. Designated Facility Owner or Operator: Certification of receipt of hazardous materials covered by the manifest except as noted in Item 18a								
Printed/Typed Name Mike Fowler				Signature <i>[Signature]</i>		Month 3	Day 18	Year 13

APPENDIX G
Photographs of UST Removal



Photo 1. Top of Redwood UST Encountered, Note Gray Contaminated Soil



Photo 2 Redwood Debris and Contaminated Soil



Photo 3. UST Excavation Approximately 8 feet bgs



Photo 4 Loading Contaminated Soil into Roll-Off Bin



Photo 5 Proximity of UST Excavation to Adjacent Building



Photo 6 Note Contaminated Soil Left in Place Beneath Foundation of Adjacent Building



Photo 7. Soil and Debris Disposed as Non-RCRA Hazardous Waste



Photo 8 Soil and Debris Disposed as Non-RCRA Hazardous Waste

APPENDIX H

UST Backfill Invoice and Weigh Tickets

Marin Resource Recovery
 565 Jacoby Street
 San Rafael, CA 94901
 PHONE (415) 485-5647
 FAX (415) 485-1509

BILLING PERIOD		4/30/13
SERVICE ADDRESS	Marin Resource Recovery 565 Jacoby Street San Rafael, CA 94901	05/10/13

Date	Description	Quantity	Rate	Amount	
4/29/13	INVOICE #: 817705 CLEAN RECYCLE BASE TKT# 0820503	14.54	12.000	174.48	
<p><i>PAID BY BRUCE FAOLI ON HIS credit card 26TH STREET OAKLAND</i></p>					
CURRENT		30 DAYS	60 DAYS	90 DAYS & OVER	174.48
174.48		0.00	0.00	0.00	
PAY THIS AMOUNT					

MARIN RESOURCE RECOVERY CENTER

TICKET # 24190

MARIN RECYCLING

WEIGHT TICKET

TEL. (415) 485-5647

DATE 4-29-13

ACCOUNT NAME Pat Latray Engineering DRIVER Ed

VEHICLE ID #DT10 JOB NUMBER _____

BOX SIZE _____ # OF YARDS _____ SERVICE AREA Oakland

GROSS WEIGHT 50660 TARE WEIGHT 21580 NET LBS 29080

NET TONS 14.54 COMMODITY Clean Base Rock

CUSTOMER SIGNATURE [Signature] ATTENDANT SIGNATURE [Signature]

REMARKS _____

*PAID By Bruce
PAOLI*

ON HIS credit CARD

*26th
ST. OAKLAND*

DATE	MAT DESC	TICKET	CUST NAME	TONS	COMMENT
2/11/2013	CLEAN BASE ROCK	797776	LA TRAY ENGINEERING	11.84	26TH AVE/OAKLAND/23412
2/11/2013	CLEAN BASE ROCK	797777	LA TRAY ENGINEERING	12.13	26TH AVE/OAKLAND/23411
2/13/2013	CLEAN BASE ROCK	798475	LA TRAY ENGINEERING	12.79	OAKLAND/23449
2/13/2013	CLEAN BASE ROCK	798476	LA TRAY ENGINEERING	12.64	OAKLAND/23420
3/13/2013	CLEAN BASE ROCK	805971	LA TRAY ENGINEERING	22.59	OAKLAND/23967
3/14/2013	CLEAN BASE ROCK	806363	LA TRAY ENGINEERING	12.58	OAKLAND/24023
3/16/2013	CLEAN BASE ROCK	806973	LA TRAY ENGINEERING	13.6	OAKLAND/23972
3/16/2013	CLEAN BASE ROCK	806974	LA TRAY ENGINEERING	13.21	OAKLAND/23971
3/16/2013	CLEAN BASE ROCK	806975	LA TRAY ENGINEERING	13.21	OAKLAND/24019
3/20/2013	CLEAN BASE ROCK	808050	LA TRAY ENGINEERING	12.7	OAKLAND/23975/PAID BY CHECK 3-20-13

MAXIM RESOURCE & RECYCLE
 SAN RAFAEL

APPENDIX I
Soil Sampling
Standard Operating Procedures



U. S. EPA ENVIRONMENTAL RESPONSE TEAM

STANDARD OPERATING PROCEDURES

SOP: 2012
PAGE: 1 of 13
REV: 0.0
DATE: 02/18/00

SOIL SAMPLING

CONTENTS

- 1.0 SCOPE AND APPLICATION
- 2.0 METHOD SUMMARY
- 3.0 SAMPLE PRESERVATION, CONTAINERS, HANDLING, AND STORAGE
- 4.0 POTENTIAL PROBLEMS
- 5.0 EQUIPMENT
- 6.0 REAGENTS
- 7.0 PROCEDURES
 - 7.1 Preparation
 - 7.2 Sample Collection
 - 7.2.1 Surface Soil Samples
 - 7.2.2 Sampling at Depth with Augers and Thin Wall Tube Samplers
 - 7.2.3 Sampling at Depth with a Trier
 - 7.2.4 Sampling at Depth with a Split Spoon (Barrel) Sampler
 - 7.2.5 Test Pit/Trench Excavation
- 8.0 CALCULATIONS
- 9.0 QUALITY ASSURANCE/QUALITY CONTROL
- 10.0 DATA VALIDATION
- 11.0 HEALTH AND SAFETY
- 12.0 REFERENCES
- 13.0 APPENDIX
 - Figures



U. S. EPA ENVIRONMENTAL RESPONSE TEAM

STANDARD OPERATING PROCEDURES

SOP: 2012
PAGE: 2 of 13
REV: 0.0
DATE: 02/18/00

SOIL SAMPLING

1.0 SCOPE AND APPLICATION

The purpose of this standard operating procedure (SOP) is to describe the procedures for the collection of representative soil samples. Sampling depths are assumed to be those that can be reached without the use of a drill rig, direct-push, or other mechanized equipment (except for a back-hoe). Analysis of soil samples may determine whether concentrations of specific pollutants exceed established action levels, or if the concentrations of pollutants present a risk to public health, welfare, or the environment.

These are standard (i.e., typically applicable) operating procedures which may be varied or changed as required, dependent upon site conditions, equipment limitations or limitations imposed by the procedure. In all instances, the actual procedures used should be documented and described in an appropriate site report.

Mention of trade names or commercial products does not constitute U.S. Environmental Protection Agency (EPA) endorsement or recommendation for use.

2.0 METHOD SUMMARY

Soil samples may be collected using a variety of methods and equipment depending on the depth of the desired sample, the type of sample required (disturbed vs. undisturbed), and the soil type. Near-surface soils may be easily sampled using a spade, trowel, and scoop. Sampling at greater depths may be performed using a hand auger, continuous flight auger, a trier, a split-spoon, or, if required, a backhoe.

3.0 SAMPLE PRESERVATION, CONTAINERS, HANDLING, AND STORAGE

Chemical preservation of solids is not generally recommended. Samples should, however, be cooled and protected from sunlight to minimize any potential reaction. The amount of sample to be collected and proper sample container type are discussed in ERT/REAC SOP #2003 Rev. 0.0 08/11/94, *Sample Storage, Preservation and Handling*.

4.0 INTERFERENCES AND POTENTIAL PROBLEMS

There are two primary potential problems associated with soil sampling - cross contamination of samples and improper sample collection. Cross contamination problems can be eliminated or minimized through the use of dedicated sampling equipment. If this is not possible or practical, then decontamination of sampling equipment is necessary. Improper sample collection can involve using contaminated equipment, disturbance of the matrix resulting in compaction of the sample, or inadequate homogenization of the samples where required, resulting in variable, non-representative results.

5.0 EQUIPMENT



U. S. EPA ENVIRONMENTAL RESPONSE TEAM

STANDARD OPERATING PROCEDURES

SOP: 2012
PAGE: 3 of 13
REV: 0.0
DATE: 02/18/00

SOIL SAMPLING

Soil sampling equipment includes the following:

- Maps/plot plan
- Safety equipment, as specified in the site-specific Health and Safety Plan
- Survey equipment or global positioning system (GPS) to locate sampling points
- Tape measure
- Survey stakes or flags
- Camera and film
- Stainless steel, plastic, or other appropriate homogenization bucket, bowl or pan
- Appropriate size sample containers
- Ziplock plastic bags
- Logbook
- Labels
- Chain of Custody records and custody seals
- Field data sheets and sample labels
- Cooler(s)
- Ice
- Vermiculite
- Decontamination supplies/equipment
- Canvas or plastic sheet
- Spade or shovel
- Spatula
- Scoop
- Plastic or stainless steel spoons
- Trowel(s)
- Continuous flight (screw) auger
- Bucket auger
- Post hole auger
- Extension rods
- T-handle
- Sampling trier
- Thin wall tube sampler
- Split spoons
- Vehimeyer soil sampler outfit
 - Tubes
 - Points
 - Drive head
 - Drop hammer
 - Puller jack and grip
- Backhoe



U. S. EPA ENVIRONMENTAL RESPONSE TEAM

STANDARD OPERATING PROCEDURES

SOP: 2012
PAGE: 4 of 13
REV: 0.0
DATE: 02/18/00

SOIL SAMPLING

Reagents are not used for the preservation of soil samples. Decontamination solutions are specified in ERT/REAC SOP #2006 Rev. 0.0 08/11/94, *Sampling Equipment Decontamination*, and the site specific work plan.

7.0 PROCEDURES

7.1 Preparation

1. Determine the extent of the sampling effort, the sampling methods to be employed, and the types and amounts of equipment and supplies required.
2. Obtain necessary sampling and monitoring equipment.
3. Decontaminate or pre-clean equipment, and ensure that it is in working order.
4. Prepare schedules and coordinate with staff, client, and regulatory agencies, if appropriate.
5. Perform a general site survey prior to site entry in accordance with the site specific Health and Safety Plan.
6. Use stakes, flagging, or buoys to identify and mark all sampling locations. Specific site factors, including extent and nature of contaminant, should be considered when selecting sample location. If required, the proposed locations may be adjusted based on site access, property boundaries, and surface obstructions. All staked locations should be utility-cleared by the property owner or the On-Scene-Coordinator (OSC) prior to soil sampling; and utility clearance should always be confirmed before beginning work.

7.2 Sample Collection

7.2.1 Surface Soil Samples

Collection of samples from near-surface soil can be accomplished with tools such as spades, shovels, trowels, and scoops. Surface material is removed to the required depth and a stainless steel or plastic scoop is then used to collect the sample.

This method can be used in most soil types but is limited to sampling at or near the ground surface. Accurate, representative samples can be collected with this procedure depending on the care and precision demonstrated by the sample team member. A flat, pointed mason trowel to cut a block of the desired soil is helpful when undisturbed profiles are required. Tools plated with chrome or other materials should not be used. Plating is particularly common with garden implements such as potting trowels.

The following procedure is used to collect surface soil samples:



U. S. EPA ENVIRONMENTAL RESPONSE TEAM

STANDARD OPERATING PROCEDURES

SOP: 2012
PAGE: 5 of 13
REV: 0.0
DATE: 02/18/00

SOIL SAMPLING

1. Carefully remove the top layer of soil or debris to the desired sample depth with a pre-cleaned spade.
2. Using a pre-cleaned, stainless steel scoop, plastic spoon, or trowel, remove and discard a thin layer of soil from the area which came in contact with the spade.
3. If volatile organic analysis is to be performed, transfer the sample directly into an appropriate, labeled sample container with a stainless steel lab spoon, or equivalent and secure the cap tightly. Place the remainder of the sample into a stainless steel, plastic, or other appropriate homogenization container, and mix thoroughly to obtain a homogenous sample representative of the entire sampling interval. Then, either place the sample into appropriate, labeled containers and secure the caps tightly; or, if composite samples are to be collected, place a sample from another sampling interval or location into the homogenization container and mix thoroughly. When compositing is complete, place the sample into appropriate, labeled containers and secure the caps tightly.

7.2.2 Sampling at Depth with Augers and Thin Wall Tube Samplers

This system consists of an auger, or a thin-wall tube sampler, a series of extensions, and a "T" handle (Figure 1, Appendix A). The auger is used to bore a hole to a desired sampling depth, and is then withdrawn. The sample may be collected directly from the auger. If a core sample is to be collected, the auger tip is then replaced with a thin wall tube sampler. The system is then lowered down the borehole, and driven into the soil to the completion depth. The system is withdrawn and the core is collected from the thin wall tube sampler.

Several types of augers are available; these include: bucket type, continuous flight (screw), and post-hole augers. Bucket type augers are better for direct sample recovery because they provide a large volume of sample in a short time. When continuous flight augers are used, the sample can be collected directly from the flights. The continuous flight augers are satisfactory when a composite of the complete soil column is desired. Post-hole augers have limited utility for sample collection as they are designed to cut through fibrous, rooted, swampy soil and cannot be used below a depth of approximately three feet.

The following procedure is used for collecting soil samples with the auger:

1. Attach the auger bit to a drill rod extension, and attach the "T" handle to the drill rod.



U. S. EPA ENVIRONMENTAL RESPONSE TEAM

STANDARD OPERATING PROCEDURES

SOP: 2012
PAGE: 6 of 13
REV: 0.0
DATE: 02/18/00

SOIL SAMPLING

2. Clear the area to be sampled of any surface debris (e.g., twigs, rocks, litter). It may be advisable to remove the first three to six inches of surface soil for an area approximately six inches in radius around the drilling location.
3. Begin augering, periodically removing and depositing accumulated soils onto a plastic sheet spread near the hole. This prevents accidental brushing of loose material back down the borehole when removing the auger or adding drill rods. It also facilitates refilling the hole, and avoids possible contamination of the surrounding area.
4. After reaching the desired depth, slowly and carefully remove the auger from the hole. When sampling directly from the auger, collect the sample after the auger is removed from the hole and proceed to Step 10.
5. Remove auger tip from the extension rods and replace with a pre-cleaned thin wall tube sampler. Install the proper cutting tip.
6. Carefully lower the tube sampler down the borehole. Gradually force the tube sampler into the soil. Do not scrape the borehole sides. Avoid hammering the rods as the vibrations may cause the boring walls to collapse.
7. Remove the tube sampler, and unscrew the drill rods.
8. Remove the cutting tip and the core from the device.
9. Discard the top of the core (approximately 1 inch), as this possibly represents material collected before penetration of the layer of concern. Place the remaining core into the appropriate labeled sample container. Sample homogenization is not required.
10. If volatile organic analysis is to be performed, transfer the sample into an appropriate, labeled sample container with a stainless steel lab spoon, or equivalent and secure the cap tightly. Place the remainder of the sample into a stainless steel, plastic, or other appropriate homogenization container, and mix thoroughly to obtain a homogenous sample representative of the entire sampling interval. Then, either place the sample into appropriate, labeled containers and secure the caps tightly; or, if composite samples are to be collected, place a sample from another sampling interval into the homogenization container and mix thoroughly.

When compositing is complete, place the sample into appropriate, labeled containers and secure the caps tightly.



U. S. EPA ENVIRONMENTAL RESPONSE TEAM

STANDARD OPERATING PROCEDURES

SOP: 2012
PAGE: 7 of 13
REV: 0.0
DATE: 02/18/00

SOIL SAMPLING

11. If another sample is to be collected in the same hole, but at a greater depth, reattach the auger bit to the drill and assembly, and follow steps 3 through 11, making sure to decontaminate the auger and tube sampler between samples.
12. Abandon the hole according to applicable state regulations. Generally, shallow holes can simply be backfilled with the removed soil material.

7.2.3 Sampling with a Trier

The system consists of a trier, and a "T" handle. The auger is driven into the soil to be sampled and used to extract a core sample from the appropriate depth.

The following procedure is used to collect soil samples with a sampling trier:

1. Insert the trier (Figure 2, Appendix A) into the material to be sampled at a 0° to 45° angle from horizontal. This orientation minimizes the spillage of sample.
2. Rotate the trier once or twice to cut a core of material.
3. Slowly withdraw the trier, making sure that the slot is facing upward.
4. If volatile organic analyses are required, transfer the sample into an appropriate, labeled sample container with a stainless steel lab spoon, or equivalent and secure the cap tightly. Place the remainder of the sample into a stainless steel, plastic, or other appropriate homogenization container, and mix thoroughly to obtain a homogenous sample representative of the entire sampling interval. Then, either place the sample into appropriate, labeled containers and secure the caps tightly; or, if composite samples are to be collected, place a sample from another sampling interval into the homogenization container and mix thoroughly. When compositing is complete, place the sample into appropriate, labeled containers and secure the caps tightly.

7.2.4 Sampling at Depth with a Split Spoon (Barrel) Sampler

Split spoon sampling is generally used to collect undisturbed soil cores of 18 or 24 inches in length. A series of consecutive cores may be extracted with a split spoon sampler to give a complete soil column profile, or an auger may be used to drill down to the desired depth for sampling. The split spoon is then driven to its sampling depth through the bottom of the augured hole and the core extracted.

When split spoon sampling is performed to gain geologic information, all work should



U. S. EPA ENVIRONMENTAL RESPONSE TEAM

STANDARD OPERATING PROCEDURES

SOP: 2012
PAGE: 8 of 13
REV: 0.0
DATE: 02/18/00

SOIL SAMPLING

be performed in accordance with ASTM D1586-98, "Standard Test Method for Penetration Test and Split-Barrel Sampling of Soils".

The following procedures are used for collecting soil samples with a split spoon:

1. Assemble the sampler by aligning both sides of barrel and then screwing the drive shoe on the bottom and the head piece on top.
2. Place the sampler in a perpendicular position on the sample material.
3. Using a well ring, drive the tube. Do not drive past the bottom of the head piece or compression of the sample will result.
4. Record in the site logbook or on field data sheets the length of the tube used to penetrate the material being sampled, and the number of blows required to obtain this depth.
5. Withdraw the sampler, and open by unscrewing the bit and head and splitting the barrel. The amount of recovery and soil type should be recorded on the boring log. If a split sample is desired, a cleaned, stainless steel knife should be used to divide the tube contents in half, longitudinally. This sampler is typically available in 2 and 3 1/2 inch diameters. A larger barrel may be necessary to obtain the required sample volume.
6. Without disturbing the core, transfer it to appropriate labeled sample container(s) and seal tightly.

7.2.5 Test Pit/Trench Excavation

A backhoe can be used to remove sections of soil, when detailed examination of soil characteristics are required. This is probably the most expensive sampling method because of the relatively high cost of backhoe operation.

The following procedures are used for collecting soil samples from test pits or trenches:

1. Prior to any excavation with a backhoe, it is important to ensure that all sampling locations are clear of overhead and buried utilities.
2. Review the site specific Health & Safety plan and ensure that all safety precautions including appropriate monitoring equipment are installed as required.



U. S. EPA ENVIRONMENTAL RESPONSE TEAM

STANDARD OPERATING PROCEDURES

SOP: 2012
PAGE: 9 of 13
REV: 0.0
DATE: 02/18/00

SOIL SAMPLING

3. Using the backhoe, excavate a trench approximately three feet wide and approximately one foot deep below the cleared sampling location. Place excavated soils on plastic sheets. Trenches greater than five feet deep must be sloped or protected by a shoring system, as required by OSHA regulations.
4. A shovel is used to remove a one to two inch layer of soil from the vertical face of the pit where sampling is to be done.
5. Samples are taken using a trowel, scoop, or coring device at the desired intervals. Be sure to scrape the vertical face at the point of sampling to remove any soil that may have fallen from above, and to expose fresh soil for sampling. In many instances, samples can be collected directly from the backhoe bucket.
6. If volatile organic analyses are required, transfer the sample into an appropriate, labeled sample container with a stainless steel lab spoon, or equivalent and secure the cap tightly. Place the remainder of the sample into a stainless steel, plastic, or other appropriate homogenization container, and mix thoroughly to obtain a homogenous sample representative of the entire sampling interval. Then, either place the sample into appropriate, labeled containers and secure the caps tightly; or, if composite samples are to be collected, place a sample from another sampling interval into the homogenization container and mix thoroughly. When compositing is complete, place the sample into appropriate, labeled containers and secure the caps tightly.
7. Abandon the pit or excavation according to applicable state regulations. Generally, shallow excavations can simply be backfilled with the removed soil material.

8.0 CALCULATIONS

This section is not applicable to this SOP.

9.0 QUALITY ASSURANCE/QUALITY CONTROL

There are no specific quality assurance (QA) activities which apply to the implementation of these procedures. However, the following QA procedures apply:

1. All data must be documented on field data sheets or within site logbooks.
2. All instrumentation must be operated in accordance with operating instructions as supplied by the manufacturer, unless otherwise specified in the work plan. Equipment checkout and calibration



U. S. EPA ENVIRONMENTAL RESPONSE TEAM

STANDARD OPERATING PROCEDURES

SOP: 2012
PAGE: 10 of 13
REV: 0.0
DATE: 02/18/00

SOIL SAMPLING

activities must occur prior to sampling/operation, and they must be documented.

10.0 DATA VALIDATION

This section is not applicable to this SOP.

11.0 HEALTH AND SAFETY

When working with potentially hazardous materials, follow U.S. EPA, OSHA and corporate health and safety procedures, in addition to the procedures specified in the site specific Health & Safety Plan..

12.0 REFERENCES

Mason, B.J. 1983. Preparation of Soil Sampling Protocol: Technique and Strategies. EPA-600/4-83-020.

Barth, D.S. and B.J. Mason. 1984. Soil Sampling Quality Assurance User's Guide. EPA-600/4-84-043.

U.S. Environmental Protection Agency. 1984 Characterization of Hazardous Waste Sites - A Methods Manual: Volume II. Available Sampling Methods, Second Edition. EPA-600/4-84-076.

de Vera, E.R., B.P. Simmons, R.D. Stephen, and D.L. Storm. 1980. Samplers and Sampling Procedures for Hazardous Waste Streams. EPA-600/2-80-018.

ASTM D 1586-98, ASTM Committee on Standards, Philadelphia, PA.



U. S. EPA ENVIRONMENTAL RESPONSE TEAM

STANDARD OPERATING PROCEDURES

SOP: 2012
PAGE: 11 of 13
REV: 0.0
DATE: 02/18/00

SOIL SAMPLING

APPENDIX A
Figures
SOP #2012
February 2000



U. S. EPA ENVIRONMENTAL RESPONSE TEAM

STANDARD OPERATING PROCEDURES

SOP: 2012
PAGE: 12 of 13
REV: 0.0
DATE: 02/18/00

SOIL SAMPLING

FIGURE 1. Sampling Augers

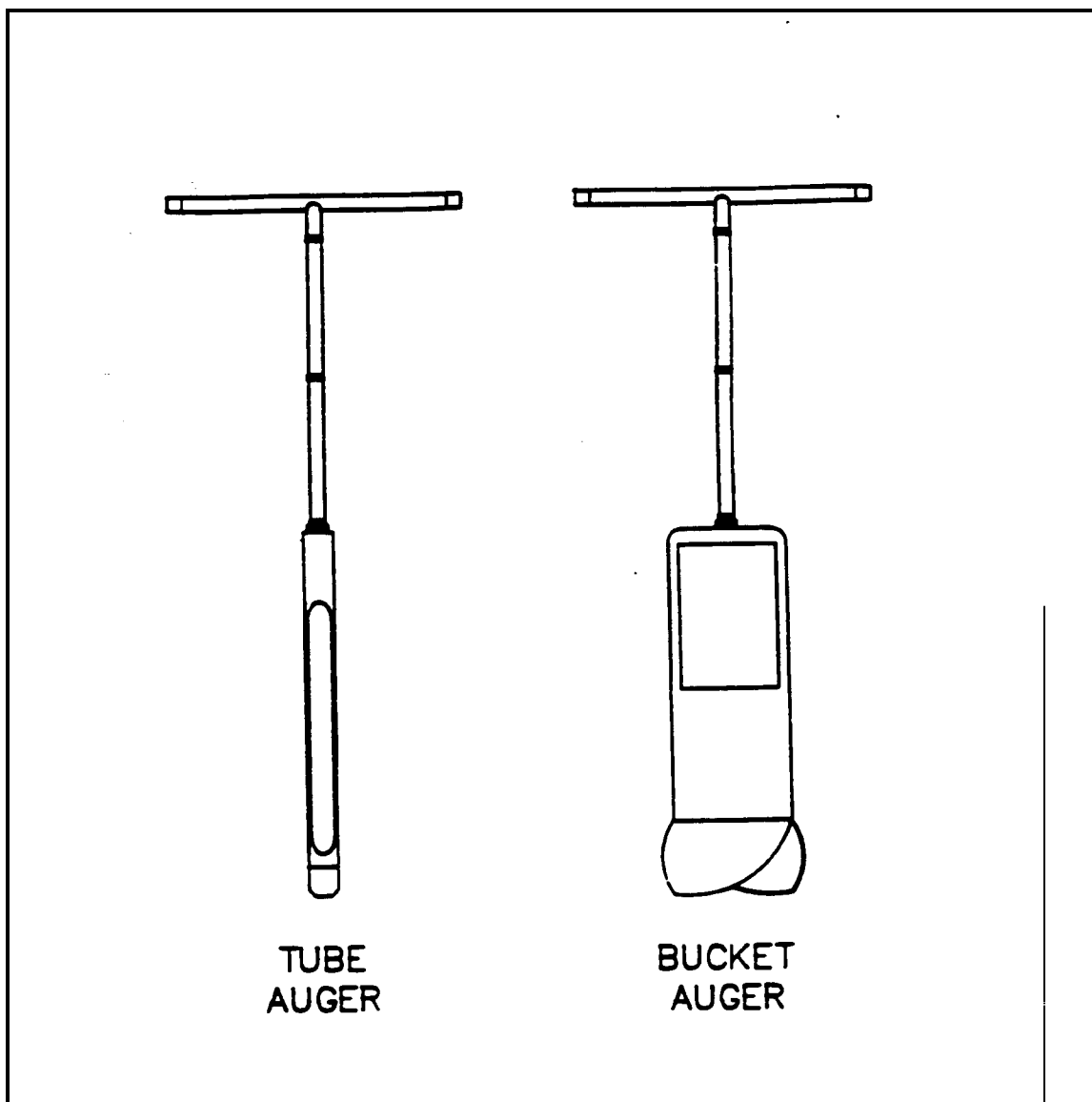



U. S. EPA ENVIRONMENTAL RESPONSE TEAM

STANDARD OPERATING PROCEDURES

SOP: 2012
PAGE: 13 of 13
REV: 0.0
DATE: 02/18/00

SOIL SAMPLING

FIGURE 2. Sampling Trier

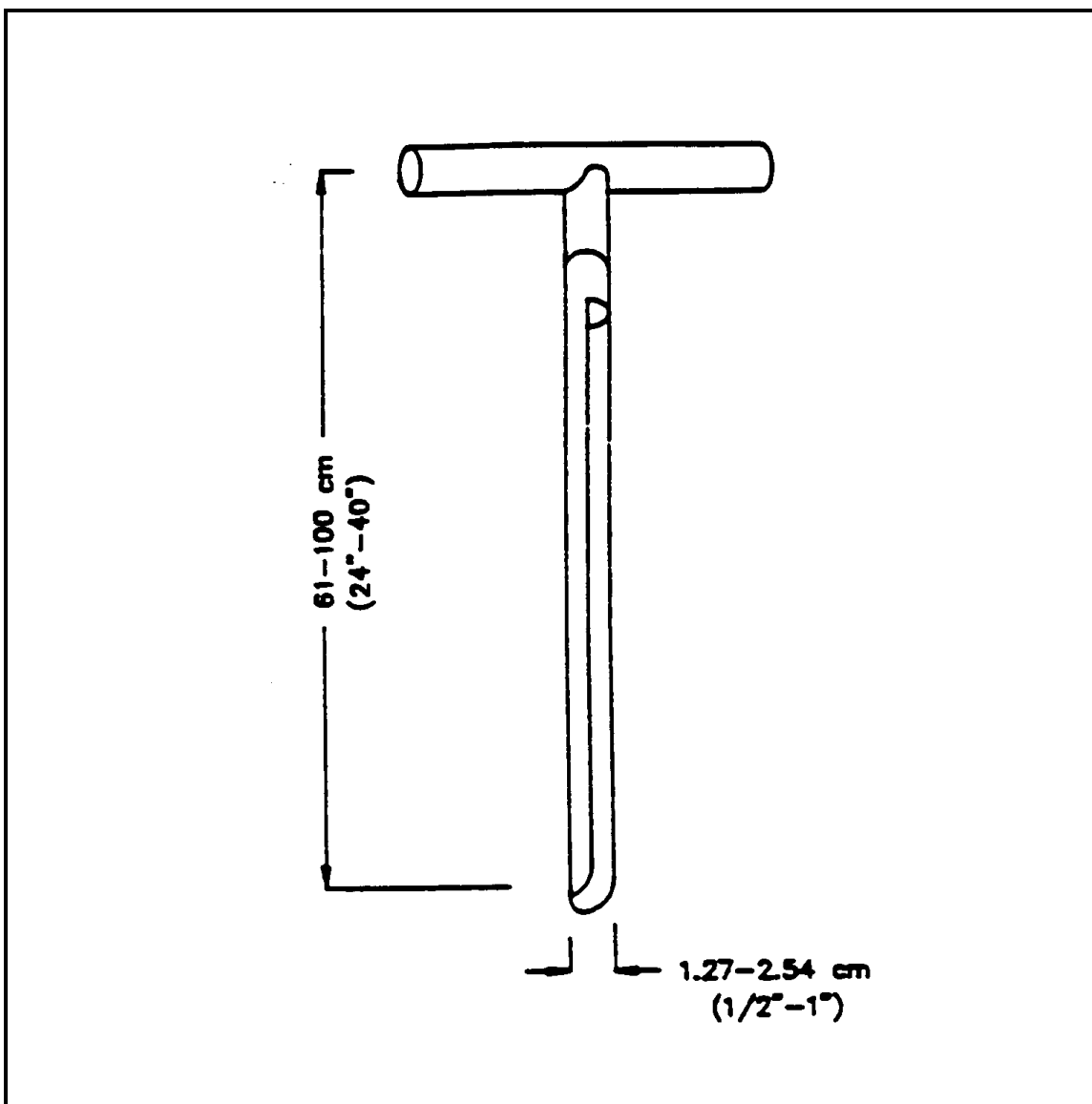

APPENDIX J

Sample Boring Log

Boring Location:	Cook Environmental Services, Inc.		
	1485 Treat Blvd., Ste 203A, Walnut Creek, CA 94597, (925) 478-8390 (925) 787-6869 cell, tcook@cookenvironmental.com, www.cookenvironmental.com		
	PROJECT:	PROJECT NO.	BORING NO:
	DRILLING CONTRACTOR:	START TIME: FINISH TIME:	DATE:
	DRILLING METHOD:	TOTAL DEPTH:	DEPTH TO WATER:
	SAMPLER:	SCREEN INT.:	CASING:
HAMMER WEIGHT::	DROP:	FIELD GEOLOGIST:	

DEPTH (FEET)	SAMPLE No	INTERVAL	BLOWS/ 0.5 FOOT	PID [ppm]	BORING/WELL CONSTRUCTION DETAIL	GRAPHIC LOG	LITHOLOGIC DESCRIPTION
- 2.5 -							
- 5 -							
- 7.5 -							
- 10 -							
- 12.5 -							
- 15 -							
- 17.5 -							
- 20 -							

Checked by: _____