

RECEIVED

By Alameda County Environmental Health 10:59 am, Sep 13, 2016



SITE MITIGATION PLAN

FOR THE SITE LOCATED AT:

2145 35TH AVENUE

OAKLAND, CALIFORNIA 94601

PREPARED FOR:

SALISBURY AVENUE ASSOCIATES LLC

PREPARED BY:

EAGLE ENVIRONMENTAL CONSTRUCTION (EEC)

1485 BAYSHORE BOULEVARD, SUITE 374



SAN FRANCISCO, CA 94124

SEPTEMBER 2016

Certification of this SMP and Perjury Statement

All engineering information, conclusions, and recommendations contained in this site mitigation plan (SMP) have been prepared by a California Professional Engineer.

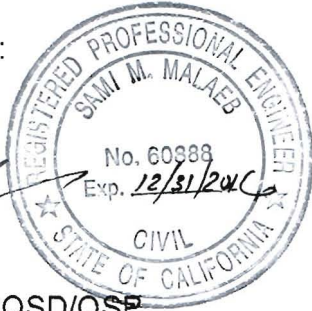
Report Prepared by:



Sami Malaeb, P.E., QSD/QSP
Project Manager

I declare under penalty of perjury, that the information and/or recommendations contained in this report are true and correct to the best of my knowledge.



Salisbury Avenue Associates LLC

Charles Thomas Shurstad

Property Owner

Managing Partner



1485 Bayshore Boulevard, Suite 374, San Francisco, CA 94124

Table of Contents

1.0	INTRODUCTION	1
2.0	BACKGROUND AND PURPOSE.....	1
3.0	PROJECT DESCRIPTION.....	2
4.0	Future Mitigation Plan During Construction.....	2
4.1	Regulatory Framework for Waste Classification.....	2
4.2	Soil Handling and Management Procedures.....	4
4.2.1	Health and Safety Plan	4
4.2.2	Sampling and Analysis of Excavated Soil.....	4
4.2.3	Soil Handling and Management Procedures.....	5
4.2.4	Soil Transporter and Disposal Locations.....	6
4.2.5	Dust Mitigation Compliance	7
4.2.6	Management Procedures for Groudwater/Rainwater	8
5.0	CONTINGENCY PLAN FOR DEALING WITH UNKNOWN CONDITIONS	9
5.1	Contingency Plan for Contaminated Soil or Unexpected Materials	9
5.2	Contingency Plan for Contaminated Water	10
6.0	NOISE CONTROL.....	10
7.0	LIMITATIONS	11
8.0	SMP CERTIFICATION AND PERJURY STATEMENT.....	12

FIGURES

FIGURE 1 SITE LOCATION

FIGURE 2 FUTURE SITE PLAN

TABLE

TABLE 1 GROUNDWATER ANALYTICAL RESULTS FOR PETROLEUM HYDROCARBONS

APPENDIX

APPENDIX A *BUILDING PLANS*

APPENDIX B *HEALTH AND SAFETY PLAN*

1.0 INTRODUCTION

This submittal is a site mitigation plan (SMP) prepared for the property located at 2145 35th Avenue, Oakland, California (the property). Figure 1 depicts the location of the property. This SMP is to be implemented during future construction of the residential units onsite and in specific, during any soil excavation or groundwater purging at the property.

In an email dated February 04, 2016, Alameda County Environmental Health (ACEH) requested a robust SMP to deal with the future soil excavation and possible groundwater purging onsite during construction. A specific workplan for soil excavation and disposal of known impacted soil with combined concentration of Total Petroleum Hydrocarbons as Gasoline (TPH-G) and Total Petroleum Hydrocarbons as Diesel (TPH-D) of 100 mg/kg or higher near boring BH5 was sent to ACEH on September 01, 2016. This SMP is prepared as a separate document for use by the construction contractor to understand the procedures in dealing with any contamination or unknown objects onsite.

2.0 BACKGROUND AND PURPOSE

The onsite soil and groundwater investigation performed through 2012 was documented in a report titled “Phase II Environmental Investigation Report and Supplemental Investigation Workplan” dated August 2012. The 2012 report documented the following:

- Removal of the car maintenance pit;
- Removal of the hydraulic lift;
- Removal of the dispenser island and associated piping;
- Drilling of fifteen soil borings onsite with soil and groundwater sampling and analysis;
- Installation and closing of 4 temporary piezometers; and
- Drilling and sampling of four monitoring wells

The offsite soil and groundwater investigation performed in 2013 was documented in a report titled “Soil and Groundwater Investigation Report”, dated November 12, 2013. The 2013 report documented the drilling and sampling of additional 10 offsite borings.

The latest groundwater monitoring report for the four monitoring wells onsite was dated August 10, 2016. The laboratory results for petroleum hydrocarbons from the monitoring wells onsite are summarized in the attached Table 1.

The soil gas sampling and analysis onsite and at the nearby apartment building property were summarized in the a report titled “Report for Supplemental Data Gap Investigation and Focused Conceptual Site Model Update at 2145 35th Avenue, Oakland, California 94601, date November 2015”.

The lead impacted soil above 80 mg/kg (ESL for residential land use) has been excavated and disposed of offsite at a regulated landfill. The excavation and disposal of known impacted soil with combined concentration of Total Petroleum Hydrocarbons as Gasoline (TPH-G) and Total Petroleum Hydrocarbons as Diesel (TPH-D) of 100 mg/kg or higher near boring BH5 is expected to occur in the near future and before proceeding with the future construction.

Therefore, based on the analytical findings to date, no known significant impact to soil will be left at the time of soil excavation to make room for the foundation slab and footings onsite. Also, no groundwater purging is expected to occur at the property during construction. This SMP is prepared as a contingency for any future unknown contamination in soil and groundwater encountered during future construction activities onsite.

For more information regarding the property refer to the State of California Geotracker site: http://geotracker.waterboards.ca.gov/profile_report?global_id=T0619778840 or the Alameda County Environmental Health ftp site: <https://www.acgov.org/aceh/lop/index.htm>. The documents and regulatory correspondences for the property are uploaded onto these two sites.

3.0 PROJECT DESCRIPTION

The project proposes construction of 5 residential units (Figure 2). No basement is planned for this building. In the process of constructing the building, soil excavation will be necessary for erecting the foundations, utility trenches, and making room for a base concrete slab. The attached appendix A contains the foundation and building plans.

We estimate soil to a maximum depth of approximately 2.5 feet bsg to be excavated. This excavation is needed to allow for the 2-foot base concrete slab to be erected and the foundation footings to be installed. No elevator is planned for this building. The shallow groundwater onsite is approximately 9 to 11 feet bsg. No groundwater is likely to be encountered during the soil excavation.

4.0 Future Mitigation Plan During Construction

4.1 Regulatory Framework for Waste Classification

The below discussion of regulatory framework is presented as a brief background in understanding the soil management and classification that may be encountered during the soil excavation and handling at this site. From the history of the site and analytical findings, it is unlikely to encounter any hazardous soil at the property. However, as a precaution, the below information is presented:

Hazardous waste in California is regulated primarily under the authority of the Federal Resource, Conservation, and Recovery Act (RCRA) and the California Health and Safety Code. Regulatory criteria to classify a waste as RCRA or non-RCRA hazardous waste are included in

the California Code of Regulations (CCR), Title 22, Division 4.5, Chapter 11, Article 3, and Chapter 40 of the Code of Federal Regulations (40 CFR), Chapter 1, Part 261.

Worker's health and safety, and public safety are key issues when dealing with hazardous materials and wastes that may affect human health and the environment. Proper handling and disposal of hazardous materials or wastes is vital if it is disturbed during project construction.

In the course of the project, soil containing petroleum hydrocarbons, metals, and other contaminants may be encountered and need to be properly managed. Such a waste may fall under one of the categories mentioned below:

Non-RCRA Hazardous Wastes: Non-RCRA Hazardous Wastes are:

- Listed (M list)
- Corrosive solid
- Toxic for anything except for federal toxicity (TCLP) [Title 22 CCR §66261.24(a)(1)]
- Excluded under 40 CFR 261.4 and exhibit any of the Article 3 criteria
- Containers are "RCRA empty" but not "California empty"

The category that is likely to be dealt with at petroleum hydrocarbon impacted sites is the toxicity criteria. For a waste containing metals or any of the constituents listed in the pertaining tables in Title 22 CCR §66261.24(a)(1)8, the waste is classified as non-RCRA when: 1) the total metal content exceeds its Total Threshold Limit Concentration (TTLC); or 2) the soluble metal content exceeds its Soluble Threshold Limit Concentration (STLC). In general, soil with a total concentration (TTLC) of 10 times the STLC concentration would trigger the analysis for STLC. In case of lead (Pb), should STLC testing detect 5 mg/l or above of lead, the soil is classified as non-RCRA hazardous waste. It is an unlikely scenario onsite since lead impacted soil has been removed from the property.

RCRA Hazardous Wastes: Wastes that are presumed to be RCRA hazardous wastes, unless otherwise determined are:

- Listed wastes (F,K,P,U lists)
- Ignitable
- Corrosive liquid
- Reactive
- Toxic (using TCLP)
- Has not been delisted or excluded

Again, the category that is likely to be considered from the above bulleted items is the toxicity criteria. A material is classified as RCRA hazardous waste when the soluble metal content exceeds the Federal Regulatory Level based on Toxicity Characteristic Leaching Procedure (TCLP) testing. In case of lead (Pb), should TCLP testing detect 5 mg/l or above of lead, the soil is classified as RCRA hazardous waste.

As for the petroleum hydrocarbons (gasoline, diesel, and motor oil), there is no specific concentration to classify the waste as RCRA or non-RCRA. The waste should be considered on a case by case basis and compared to the applicable landfill requirements.

Class II and Class III Regulated Landfill Wastes: When waste does not fall into the category of RCRA or non-RCRA hazardous waste, the waste may be accepted by a local Class II or III regulated landfill. Each of these landfills has its own requirements and limits for the concentrations of contaminants in the soil.

4.2 Soil Handling and Management Procedures

4.2.1 Health and Safety Plan

Prior to performing any soil excavation, a site specific health and safety plan (H&S Plan) should be prepared and implemented at this site. EEC has prepared a H&S Plan for this job (Appendix A). The H&S Plan was prepared according to the Occupational Safety and Health Administration (OSHA) 29CFR, 1910.120. The contractor working onsite may adopt EEC's H&S Plan or use his own. Safety of contractor employees is primarily the responsibility of the contractor. Contractors are required to follow and operate within their company's health and safety program and policies. Contractors are to designate a company representative as their own Site Safety Officer. This individual shall monitor their employees and ensure safe working procedures are being followed. The contractor shall identify their Site Safety Officer and, if applicable, Assistant Safety Officer to the owner and general contractor onsite.

Contractors shall provide their own safety equipment and personal protective equipment. Contractors shall be ultimately responsible for ensuring their equipment is in proper working order and their employees are trained and medically fit to complete the work assigned to them. Upon request, contractors shall also provide evidence that personnel working at the site have received the necessary training and, if applicable, medical surveillance.

4.2.2 Sampling and Analysis of Excavated Soil

In case unknown soil contamination is encountered during construction (heavy staining, odor of petroleum hydrocarbons), the content of this section is to be applied. Soil profiling for disposal will be needed. The purpose of the soil sampling is to profile the soil for disposal and to find out the content of the soil for the protection of workers and the public. The number of samples to be collected should follow the landfill requirement. Soil sampling should be performed by a qualified professional, complying with the Hazardous Waste Operation (HAZWOPER), OSHA

29CFR1910.120 training, initial 40-hour certification and 8-hour yearly refresher course. Initial OSHA Level D protection, which will include safety boots/shoes, protective gloves, safety glasses, is sufficient for the soil sampling. The number of soil samples to be collected and the analytes should be according to the requirement of the landfill receiving the materials and for the protection of workers and receptors. The soil may be analyzed for the following:

- Title 22, CAM 17 Metals by EPA Method 6010/7471 (that is including lead, cobalt, and arsenic);
- Full range of petroleum hydrocarbons as gasoline (TPH-D), Total Petroleum Hydrocarbons as Diesel (TPH-D); Total Petroleum Hydrocarbons (TPH) as motor oil and hydraulic oil by EPA Method 8015; and benzene, toluene, ethyl benzene, and xylenes (BTEX); and
- any other analysis requested by the landfill.

Samples are recommended to be collected in brass or stainless steel tubes, capped with Teflon liners and plastic caps, to prevent volatiles from escaping. The samples are to be placed on ice in a cooler at approximately 4°Centigrade. The samples to be recorded on a chain of custody and delivered to a California certified lab by an Environmental Laboratory Accreditation Program (ELAP) for analysis.

After excavating the soil near BH5 onsite, mentioned earlier in this workplan, it is unlikely to encounter any major impact with petroleum hydrocarbons at this property. However the above plan is only if hot spot is encountered (stain, odor of petroleum hydrocarbons, or high PID reading).

4.2.3 Soil Handling and Management Procedures

Initial OSHA Level D protection, which will include coveralls, safety boots/shoes, protective gloves, safety glasses, is sufficient for the soil handling, unless the health and safety officer onsite sees higher level of protection is needed. Dust control is covered in the next section of this SMP.

All excavated soil stockpile should be placed on and covered with plastic liner for protection against wind and rain, to prevent cross contamination of other areas, and for the protection of the environment and receptors. Covered metal bins could also be used to store soil. The site should be secured by a fence and locked to prevent vandalism and exposure of public.

The Contractor shall implement, maintain, supervise and be responsible for all soil management practices during the course of the work covered under this SMP. An Environmental Professional shall be present on as needed basis.

4.2.4 Soil Transporter and Disposal Locations

Depending on the waste profile as RCRA hazardous, non-RCRA hazardous, or non-hazardous waste, the waste haulers and landfill will be as follows:

Waste Haulers

For soil classified as non-hazardous waste, the following haulers may be used:

Greg's Trucking Services Inc.
2045 Detroit Drive
San Mateo, CA 94404
(650) 343-5946

Or

S&S Trucking
477 Roland Way
Oakland, CA 94612
(510) 383-3556

Or

Another local licensed hauler will be chosen.

For soil classified as hazardous waste, the following licensed haulers may be used:

DenBeste
810 Den Beste Ct #107
Windsor, CA 95492
(800) 838-1477

Or

Another licensed hauler will be chosen.

Waste Landfills

Non-hazardous waste Class III Landfill:
Ox Mountain Landfill
12310 Highway 92

Half Moon Bay, CA 94019
(650) 7261819

Non-hazardous waste Class III or II Landfill:

Altamont Landfill
10840 Altamont Pass Rd
Livermore, CA 94551
(925) 455-7300

Class I Landfill for hazardous waste (unlikely scenario):

Clean Harbors Button Willow Landfill:
42 Longwater Drive
P.O. Box 9149
Norwell, MA 02061-9149
(781) 792-5000

Or

Through Waste Solutions Group in San Francisco by hauling by trucks to rail to the following destinations:

Non-RCRA hazardous waste:
ECDC Landfill
Near East Carbon City, Utah
(412) 826-5003

RCRA hazardous waste:

US Ecology, Inc.
251 E Front St., Suite 400
Boise, ID 83702
(800) 590-5220

4.2.5 Dust Mitigation Compliance

The purpose for the Dust Mitigation Plan is to minimize the potential of airborne dust and tracking of dirt & debris as a result of the excavation work activities. At a minimum the following procedures should be followed:

(A) Prior to any ground disturbance, sufficient water must be applied to the area to be

disturbed to prevent visible emissions from crossing the property line;

(B) Areas to be graded or excavated must be kept adequately wetted to prevent visible emissions from crossing the property line;

(C) Storage piles must be kept adequately wetted, treated with a chemical dust suppressant, or covered when material is not being added to or removed from the pile;

(D) Equipment must be washed down before moving from the property (work area) onto a paved public road; and

(E) Visible track-out on the paved public road must be cleaned and swept as soon as possible.

Decontamination of Personnel: Personnel exiting the work area during breaks, lunch or at the conclusion of the work shift shall properly decontaminate themselves and practice proper personal hygiene. Soap & water should be used to wash the hands and face. Safety shoes should be cleaned free of any dirt so as not to track on clean areas with dirt & mud. This practice should continue for the duration of the excavation project. The Dust Mitigation Plan should remain in place until such time the disturbance of soil has been eliminated.

4.2.6 Management Procedures for Groudwater/Rainwater

Due to the depth to groundwater 9 to 11 feet bsg at the property, and the planned excavation to a maximum of 2.5 feet bsg, no groundwater is likely to be encountered during the soil excavation activities. However, the procedures below are needed in case such groundwater is encountered or rain water accumulates onsite. These procedures are as follows:

- Contractor should arrange and have onsite a water storage tank (Baker tank), sufficient hoses, and pumps to deal with accumulated water in trenches and excavations onsite. The engineer onsite should calculate the volume of tank needed based on the quantity of water estimated to be encountered.
- No groundwater or rainwater should be disposed of offsite without proper profiling, sampling, and permitting.

Based on the analytical findings of groundwater sampling and analysis, petroleum hydrocarbons were detected in the groundwater. The analytes to include in the groundwater profiling and sampling will be as needed by the treatment, disposal facility receiving the waste water. See the attached Table 1 for a summary of analytical data of groundwater.

5.0 CONTINGENCY PLAN FOR DEALING WITH UNKNOWN CONDITIONS

5.1 Contingency Plan for Contaminated Soil or Unexpected Materials

The health and safety plan, prepared under OSHA 19210.120 should be available onsite and implemented by the Health and Safety officer at all times.

Contamination indicators or hazardous materials that may be accidentally encountered, may include but are not limited to the following:

- Intact or broken drums, piping, and containers, including USTs.
- Unusual odors.
- Discolored or stained water and soils.
- Petroleum hydrocarbon contaminated soil and/or free product.
- Broken containers, sheets, pipes or fragments.
- Object appearing to be historical or archeological in nature

During the excavation work onsite, the environmental professional shall actively monitor for the conditions/materials specified above. In the event that one of these is identified, the contractor should take the following actions:

- Stop all earthworks within an approximately 20 foot-radius of the area where the suspect material/emission/discharge has been recorded.
- Immediately notify the site supervisor and the environmental professional
- Cordon off the area as practicable with a suitable barrier.
- Work shall not resume or commence within the cordoned area unless authorized by the environmental professional.
- Notify ACEH and local Fire Department if needed, that unexpected contamination/objects have been discovered and a contingency action is being implemented.
- Characterize the contamination by collecting samples for chemical laboratory analysis.
- If appropriate, advise the contractor to excavate the suspected contaminated material into a covered bin or to segregate the materials into a separate, covered stockpile, to allow works to continue with minimum delay.
- When the discovered materials have been characterized, advise the site supervisor as to whether the materials may remain on site or whether materials should be directly loaded

into trucks for disposal at a licensed landfill, assuming it can be accepted without prior stabilization.

- Record all details on an incident form.

5.2 Contingency Plan for Contaminated Water

It is unlikely that groundwater be encountered at this site due to the shallow excavation, planned above the level of the shallow water. In case rain or ground water start to accumulate in the excavation area or trenches, the plan mentioned in Section 4.2.6 will be implemented.

6.0 NOISE CONTROL

The Oakland, California Code of Ordinances, Title 8/ Health and Safety/ Chapter 8.18 - Nuisances shall be applicable to the construction activities at this site. Common sense should prevail, including and not limited to:

The following acts, and the causing or permitting thereof, shall be considered disturbing the peace and shall constitute an infraction.

- Loading and Unloading. Loading, unloading, opening, closing, or other handling of boxes, crates, containers, building materials, refuse, or similar objects between the hours of nine p.m. and six a.m. in such a manner as to cause a noise disturbance across a residential property line or at any time to violate the applicable noise provisions of the Oakland Planning Code;
- Power Tools, Machinery. Operating or permitting the operation of any mechanically powered saw, sander, drill, grinder, lawn or garden tool, or similar tool between nine p.m. and six a.m. so as to create a noise disturbance across a real property line or at any time to violate the applicable noise provisions of the Oakland Planning Code;
- Creation of any noise to affect the nearby school so as to interfere with the functions of the school;
- Noise resulting from construction and demolition activities, compressors, and other commercial or industrial noises associated with land use activities, shall be regulated pursuant to standards contained within the noise regulations of the Oakland Planning Code.

- It shall be unlawful for any person to operate any powered construction equipment, regardless of age or date of acquisition, if such equipment emits noise at a level in excess of 80 dBA when measured at a distance of one hundred feet from such equipment, or equivalent sound level at some other convenient distance.

7.0 LIMITATIONS

This SMP was prepared in accordance with generally accepted engineering practices. No warranty, expressed or implied is made to the guidelines in this SMP or their applications. The guidelines in this SMP are based on the analytical findings obtained from those portions of the site that were the subject of investigation and sampling. Soils, other subsurface geological conditions, buried objects may differ outside of the investigation areas. This SMP is valid as of the present time. Legislation or the broadening of knowledge may require other recommendations.

It is the responsibility of the owner or its representative to ensure that the applicable provisions of this SMP are incorporated into the plans and specifications and that the necessary steps are taken to see that the contractors carry out such provisions in the field. Each contractor is responsible for the health and safety of his own employees onsite and complying with the local, state, and federal regulations, applicable to the type of work performed onsite.



8.0 SMP CERTIFICATION AND PERJURY STATEMENT

This SMP is uploaded to the State GeoTracker Database System, in general accordance with State Assembly Bill 2886. Also this SMP is uploaded into the ftp site of ACEH.

Thank you for your cooperation. If you have any questions, please call at (925) 858-9608 or email Sami Malaeb at s.malaeb@comcast.net.

All engineering information, conclusions, and recommendations contained in this SMP have been prepared by a California Professional Engineer.

Report Prepared by:



Sami Malaeb, P.E., QSD/QSP
Project Manager

I declare under penalty of perjury, that the information and/or recommendations contained in this report are true and correct to the best of my knowledge.



Salisbury Avenue Associates LLC

Charles Thomas Shurstad

Property Owner

Managing Partner

FIGURES

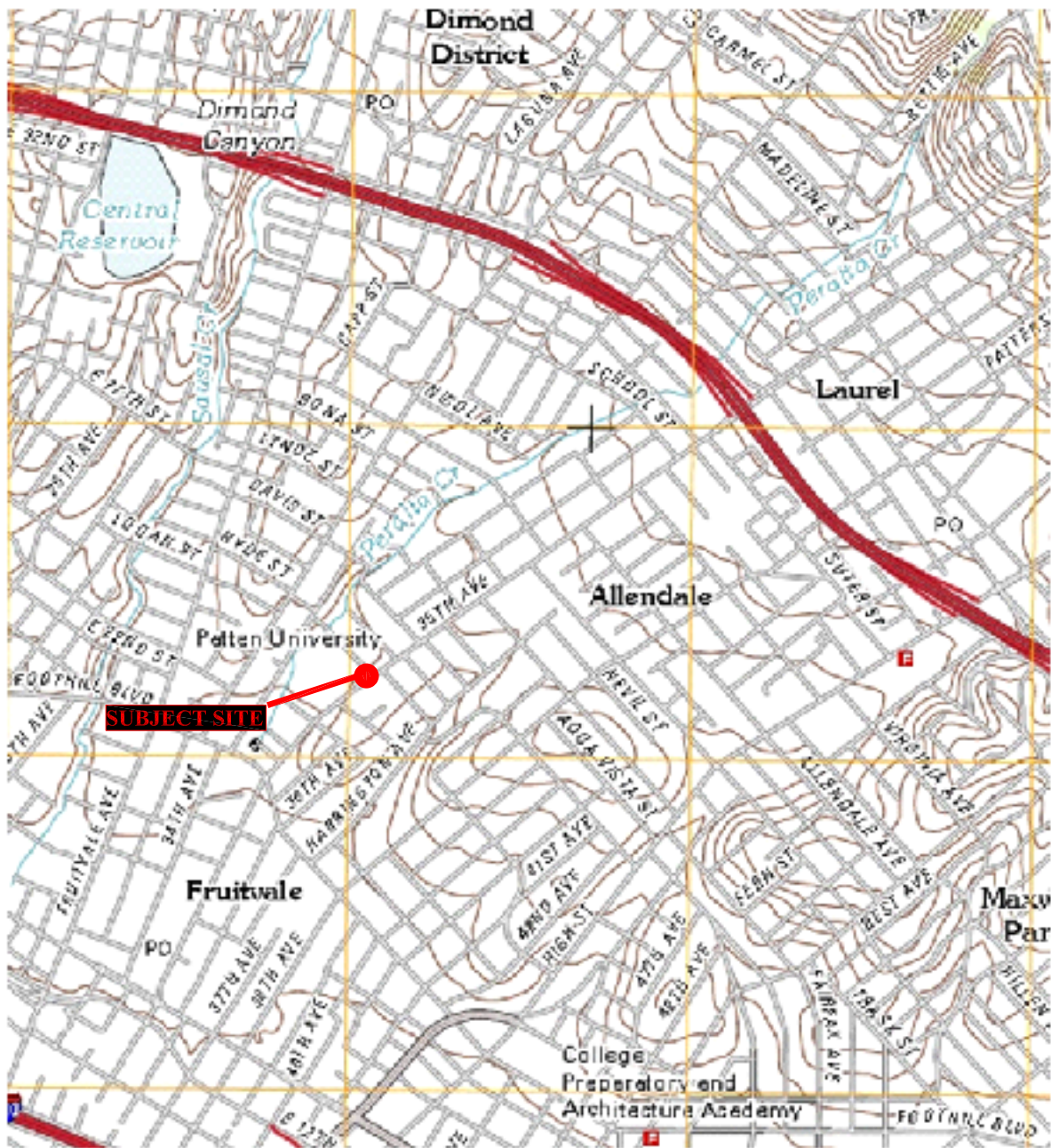

SUBJECT SITE

SCALE 1:24 000

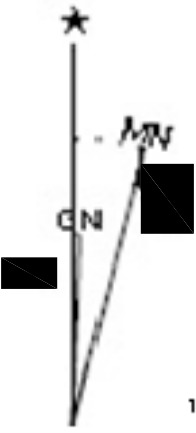
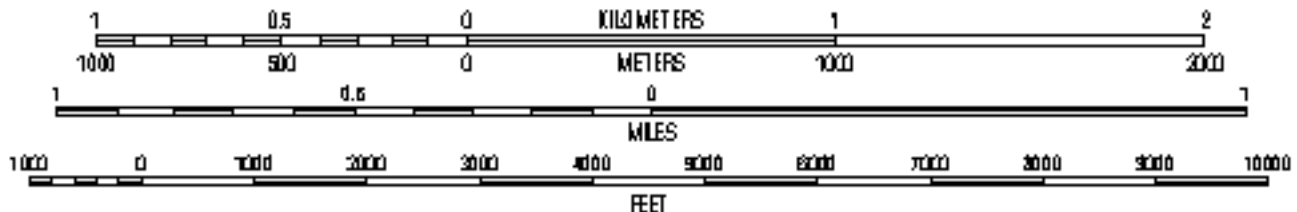

1485 BAYSHORE BOULEVARD, SUITE 374
SAN FRANCISCO, CA 94124

SITE LOCATION
2145 35TH AVENUE
OAKLAND, CA 94601

FIGURE 1

JUNE
2015

RESIDENTIAL
HOUSES

SALISBURY STREET

SIDEWALK

0 FEET 10
APPROXIMATE SCALE

SUBJECT
SITE

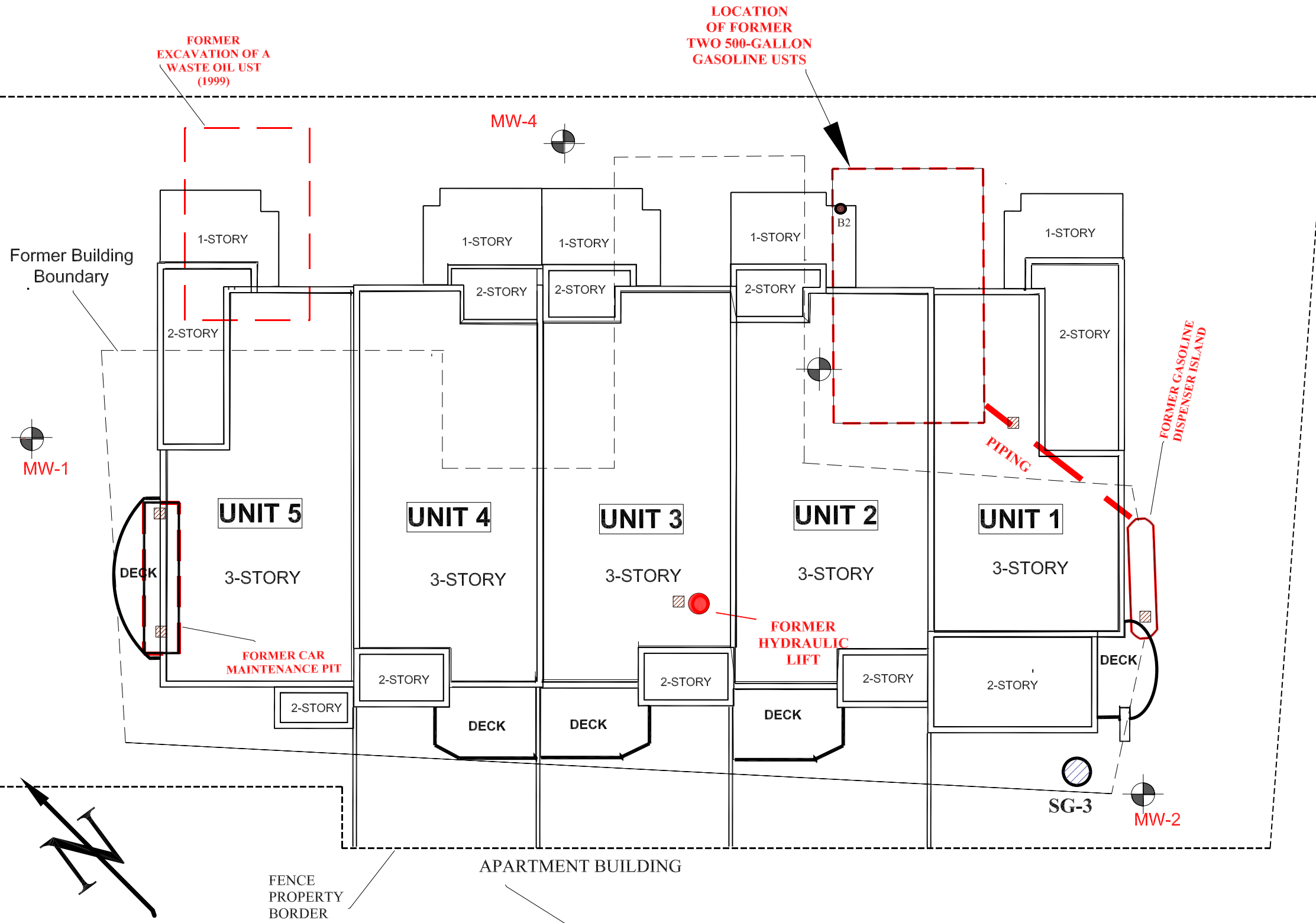

NOTE:
FUTURE BUILDING FOUNDATIONS ARE
ON THE DOUBLE LINES ALONG THE
WALLS OF THE BUILDING

35TH AVENUE

APARTMENT BUILDING



1485 BAYSHORE BOULEVARD, SUITE 374
SAN FRANCISCO, CA 94124

FUTURE SITE PLAN
2145 35TH AVENUE, OAKLAND, CALIFORNIA

FIGURE 2
SEPTEMBER 2016

TABLE 1

TABLE 1
SUMMARY OF CHEMICAL ANALYSES
GROUNWATER SAMPLES COLLECTED FROM THE MONITORING WELLS
PETROLEUM HYDROCARBONS, BTEX, and MTBE
2145 35th Avenue, Oakland, California

Sample ID	Date Sampled	TPH-G ⁽¹⁾ (µg/l) ⁽²⁾	TPH-ss ⁽³⁾ (µg/l)	TPH-D ⁽⁴⁾ (µg/l)	TPH as Motor Oil (µg/l)	TPH as Hydraulic Oil (µg/l)	Benzene (µg/l)	Toluene (µg/l)	Ethyl benzene (µg/l)	Total Xylenes (µg/l)	MTBE ⁽⁵⁾ (µg/l)	Naphthalene (µg/l)
MW-1	07/09/2012	ND<50	ND<50	ND<50	ND<300	ND<300	ND<0.5	ND<0.5	ND<0.5	ND<1.0	ND<0.5	ND<2.0
	12/06/2012	ND<50	ND<50	ND<50	ND<300	ND<300	ND<0.5	ND<0.5	ND<0.5	ND<1.0	ND<0.5	ND<2.0
	03/21/2013	ND<50	ND<50	ND<49	ND<290	ND<290	ND<0.5	ND<0.5	ND<0.5	ND<1.0	ND<0.5	ND<2.0
	06/21/2013	ND<50	ND<50	100 (Y) ⁽⁶⁾	ND<290	ND<290	ND<0.5	ND<0.5	ND<0.5	ND<1.0	ND<0.5	ND<2.0
	12/10/2013	ND<50	ND<50	ND<49	ND<290	ND<290	ND<0.5	ND<0.5	ND<0.5	ND<1.0	ND<0.5	ND<2.0
	12/04/2014	ND<50	ND<50	ND<50	ND<300	ND<300	ND<0.5	ND<0.5	ND<0.5	ND<1.0	ND<0.5	ND<2.0
	08/10/2016	ND<50	ND<50	ND<50	ND<300	ND<300	ND<0.5	ND<0.5	ND<0.5	ND<1.0	ND<0.5	ND<2.0
MW-2	07/09/2012	3,800	3,900 (Y)	1,200 (Y)	ND<300	660 (Y)	82	42	350	189.4	ND<0.5	44
	12/06/2012	5,000	3,300 (Y)	2,300	ND<300	1,500 (Y)	92	42	460	179.6	ND<0.5	62
	03/21/2013	4,500	3,000	1,800 Y	ND<300	1,000(Y)	77	31	230	115.4	ND<1.7	25
	06/21/2013	4,300	2,900	1,700 (Y)	ND<300	1,100 (Y)	50	24	210	96	ND<1.7	21
	12/10/2013	3,300	2,300 (Y)	1,500 (Y)	ND<300	710 (Y)	40	21	140	63	ND<1.7	6.7
	12/04/2014	4,600	3,200 (Y)	3,900	ND<300	1,300 (Y)	53	24	200	75.2	ND<1.7	30
	08/10/2016	3,800	3,100 (Y)	590 (Y)	ND<300	ND<300	61	28	38	31.2	ND<0.5	3.5
MW-3	07/09/2012	85Y	86Y	180 (Y)	ND<300	ND<300	0.8	ND<0.5	ND<0.5	ND<1.0	ND<0.5	ND<2.0
	12/06/2012	1,200	800Y	2,000	ND<300	1,600 (Y)	36	0.8	9.2	1.1	ND<0.5	120
	03/21/2013	130 (Y)	91Y	140 (Y)	ND<300	ND<290	1.8	ND<0.5	ND<0.5	ND<1.0	ND<0.5	ND<2.0
	06/21/2013	ND<50	ND<50	210 (Y)	ND<300	340 (Y)	ND<0.5	ND<0.5	ND<0.5	ND<1.0	ND<0.5	ND<2.0
	12/10/2013	ND<50	ND<50	54 (Y)	ND<300	ND<290	ND<0.5	ND<0.5	ND<0.5	ND<1.0	ND<0.5	ND<2.0
	12/04/2014	54 (Y)	ND<50	ND<50	ND<300	ND<300	ND<0.5	ND<0.5	ND<0.5	ND<1.0	ND<0.5	ND<2.0
	08/10/2016	ND<50	ND<50	ND<50	ND<300	ND<300	ND<0.5	ND<0.5	ND<0.5	ND<1.0	ND<0.5	ND<2.0
MW-4	07/09/2012	ND<50	ND<50	ND<50	ND<300	ND<300	ND<0.5	ND<0.5	ND<0.5	ND<1.0	ND<0.5	ND<2.0
	12/06/2012	ND<50	ND<50	ND<50	ND<300	ND<300	ND<0.5	ND<0.5	ND<0.5	ND<1.0	ND<0.5	ND<2.0
	03/21/2013	ND<50	ND<50	ND<49	ND<290	ND<290	ND<0.5	ND<0.5	ND<0.5	ND<1.0	ND<0.5	ND<2.0
	06/21/2013	ND<50	ND<50	76 (Y)	ND<290	ND<290	ND<0.5	ND<0.5	ND<0.5	ND<1.0	ND<0.5	ND<2.0
	12/10/2013	ND<50	ND<50	ND<51	ND<310	ND<310	ND<0.5	ND<0.5	ND<0.5	ND<1.0	ND<0.5	ND<2.0
	12/04/2014	ND<50	ND<50	ND<50	ND<300	ND<300	ND<0.5	ND<0.5	ND<0.5	ND<1.0	ND<0.5	ND<2.0
	08/10/2016	ND<50	ND<50	ND<50	ND<300	ND<300	ND<0.5	ND<0.5	ND<0.5	ND<1.0	ND<0.5	ND<2.0
Groundwater Screening Levels, Low-Threat Underground Storage Tank Case Closure Policy, Appendix 3, Figure A ⁽⁷⁾		NA ⁽⁷⁾	NA	NA	NA	NA	100	NA	NA	NA	NA	NA

TPH-G ⁽¹⁾ = Total petroleum hydrocarbons as gasoline by EPA Method 8015B
($\mu\text{g/l}$) ⁽²⁾ = Microgram per liter
TPH-ss ⁽³⁾ = Total petroleum hydrocarbons as Stoddard solvent by EPA Method 8015B
TPH-D ⁽⁴⁾ = Total petroleum hydrocarbons as diesel by EPA Method 8015B
MTBE ⁽⁵⁾ = Methyl Tertiary Butyl Ether
(Y) ⁽⁶⁾ = Sample exhibits chromatographic pattern which does not resemble standard;

NA ⁽⁷⁾ = Not Applicable

APPENDIX A BUILDING PLANS

This drawing is the property of the Architect and may not be reproduced or used without his written permission.
 Dan Ionescu Architects & Planners
 © Copyright 2007 DIAP

SALISBURY VILLAGE

LOCATION
 2145 35TH AVENUE
 OAKLAND, CALIFORNIA 94612
 PROJECT PHASE JOB N°
 CONSTRUCTION DOCUMENT 0816

SITE PLAN

SCALE DATE
 1/8"=1'-0" APRIL, 2007

ISSUES / REVISIONS

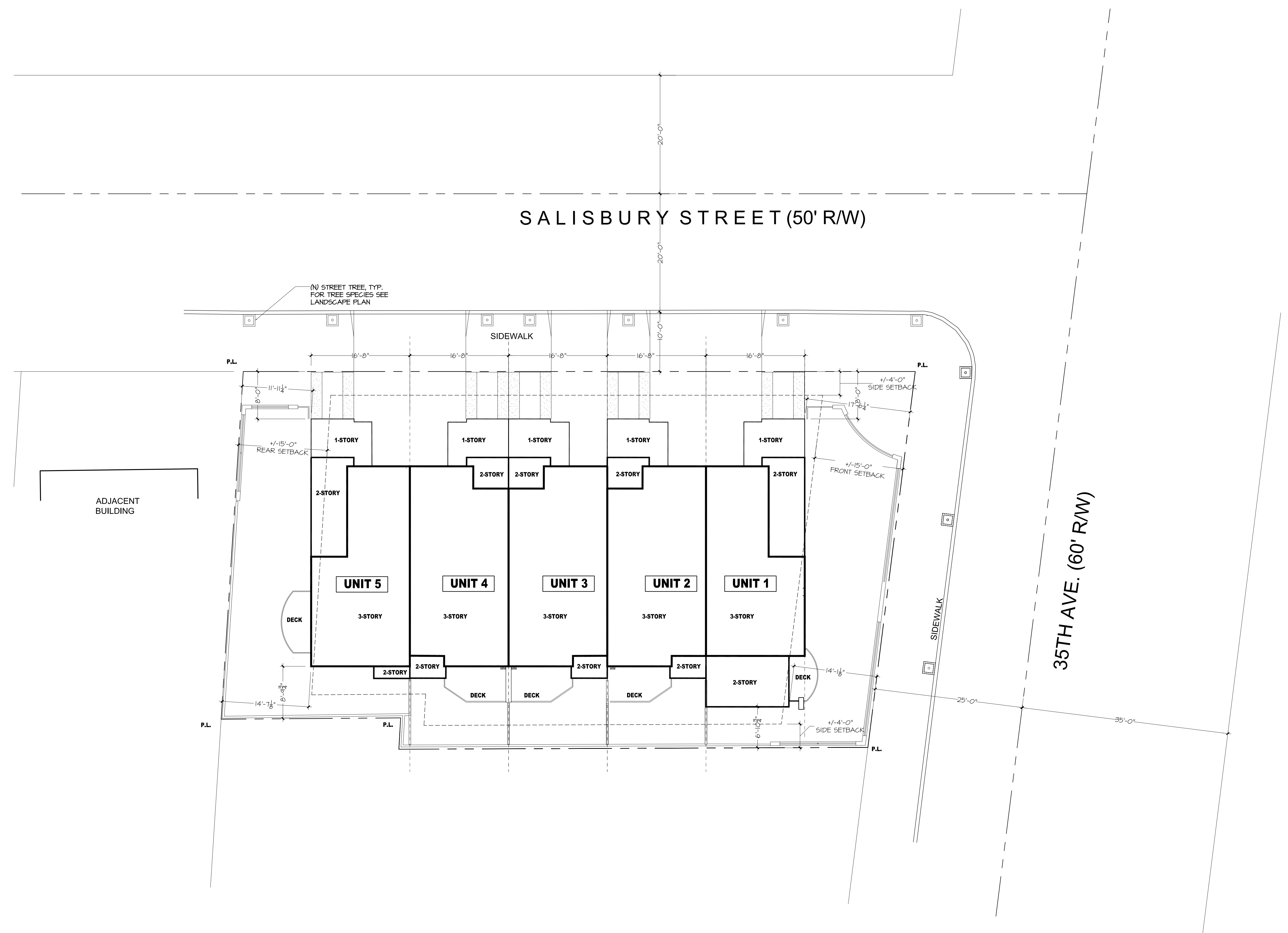

1 SITE PLAN PROJECTS/0616 SALISBURY VILLAGE/4 CONSTRUCTION DOCUMENTS/A1-1 03-2007 [1/96X9]

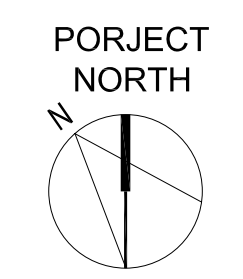

SALISBURY VILLAGE

LOCATION
SALISBURY ST.
OAKLAND, CALIFORNIA
PROJECT PHASE _____ JOB NO. _____
STRUCTURAL _____ JOB NO. 95324

SCALE: AS SHOWN
DATE _____

ISSUES / REVISIONS

S3.1

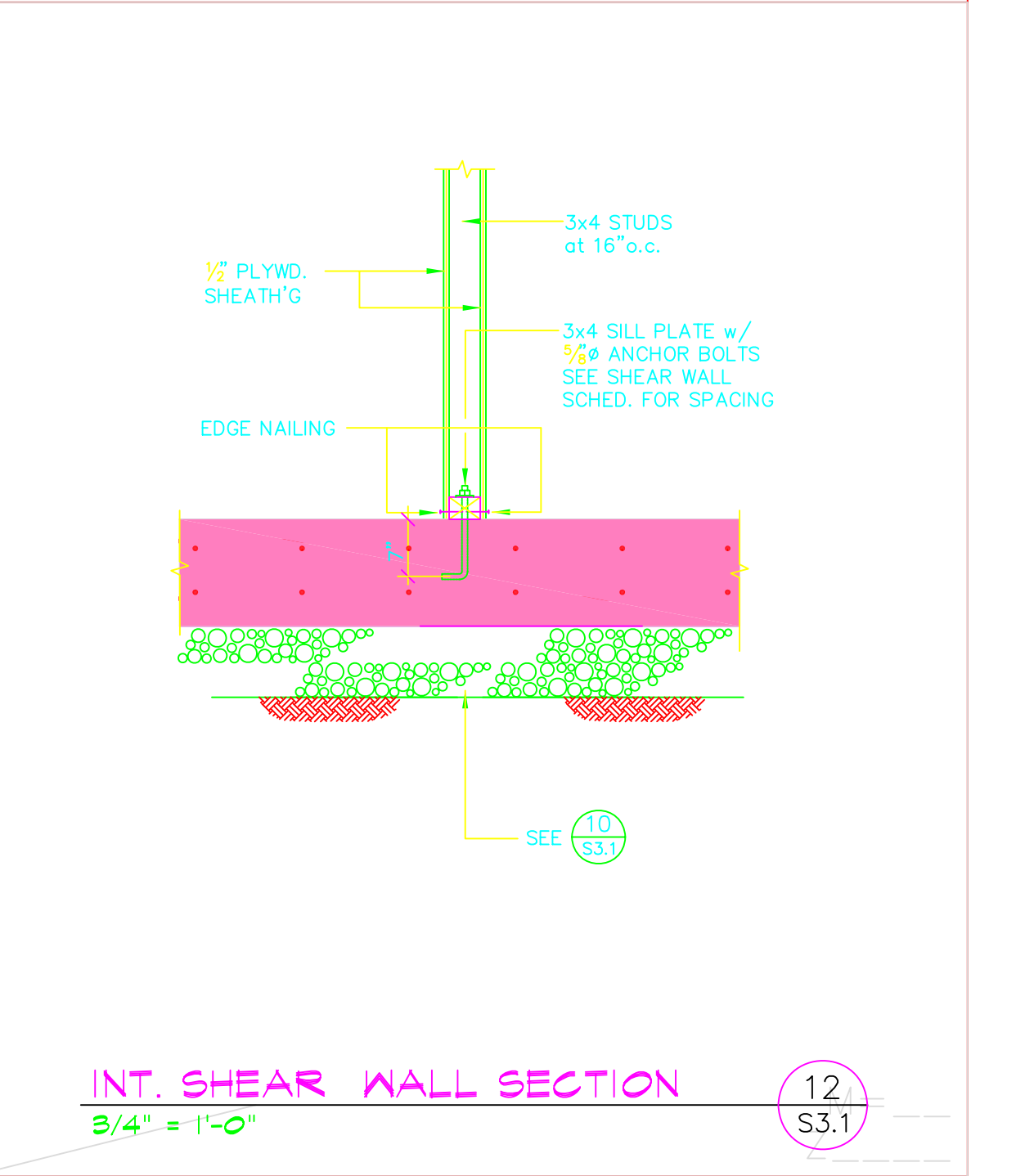
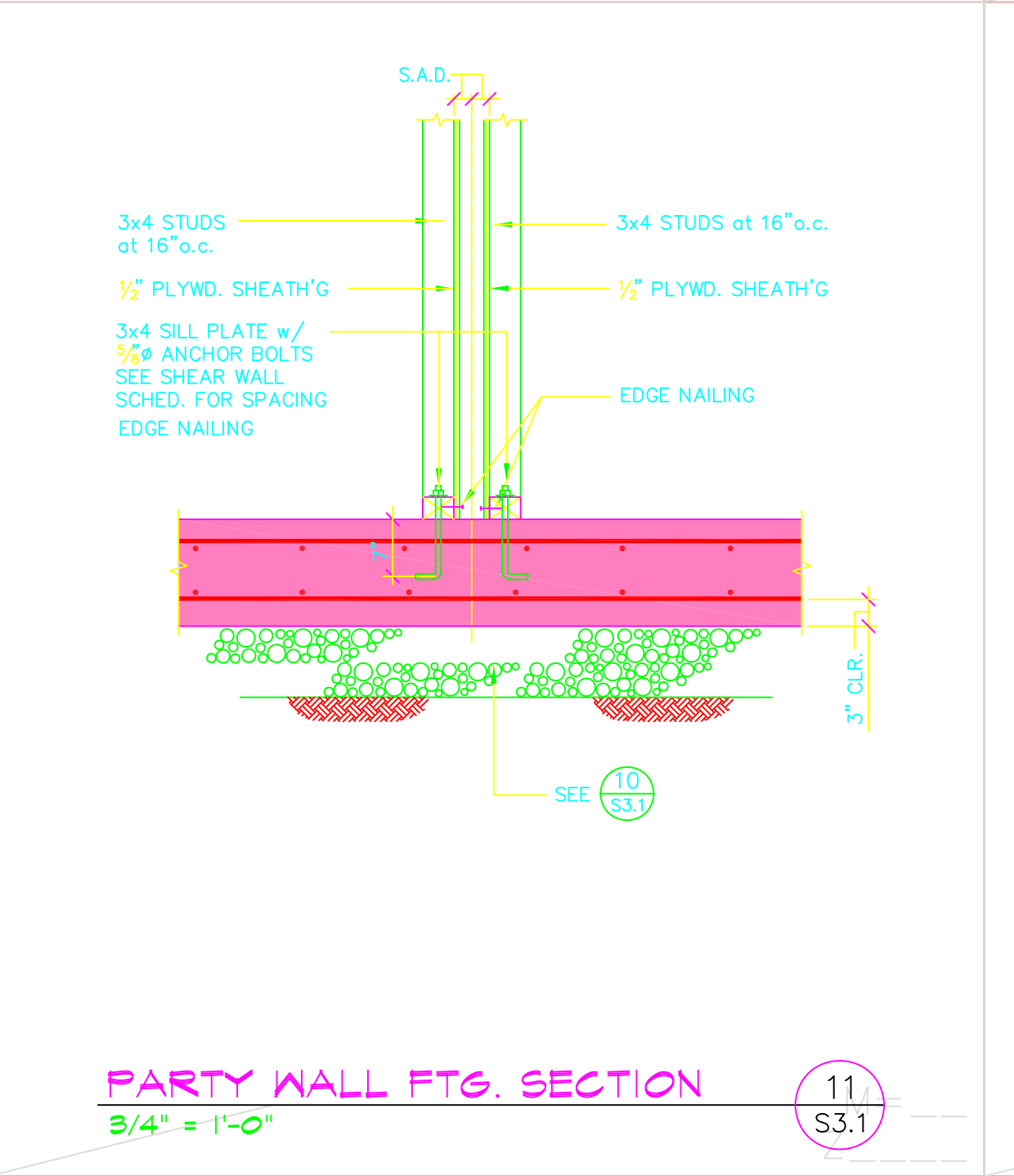
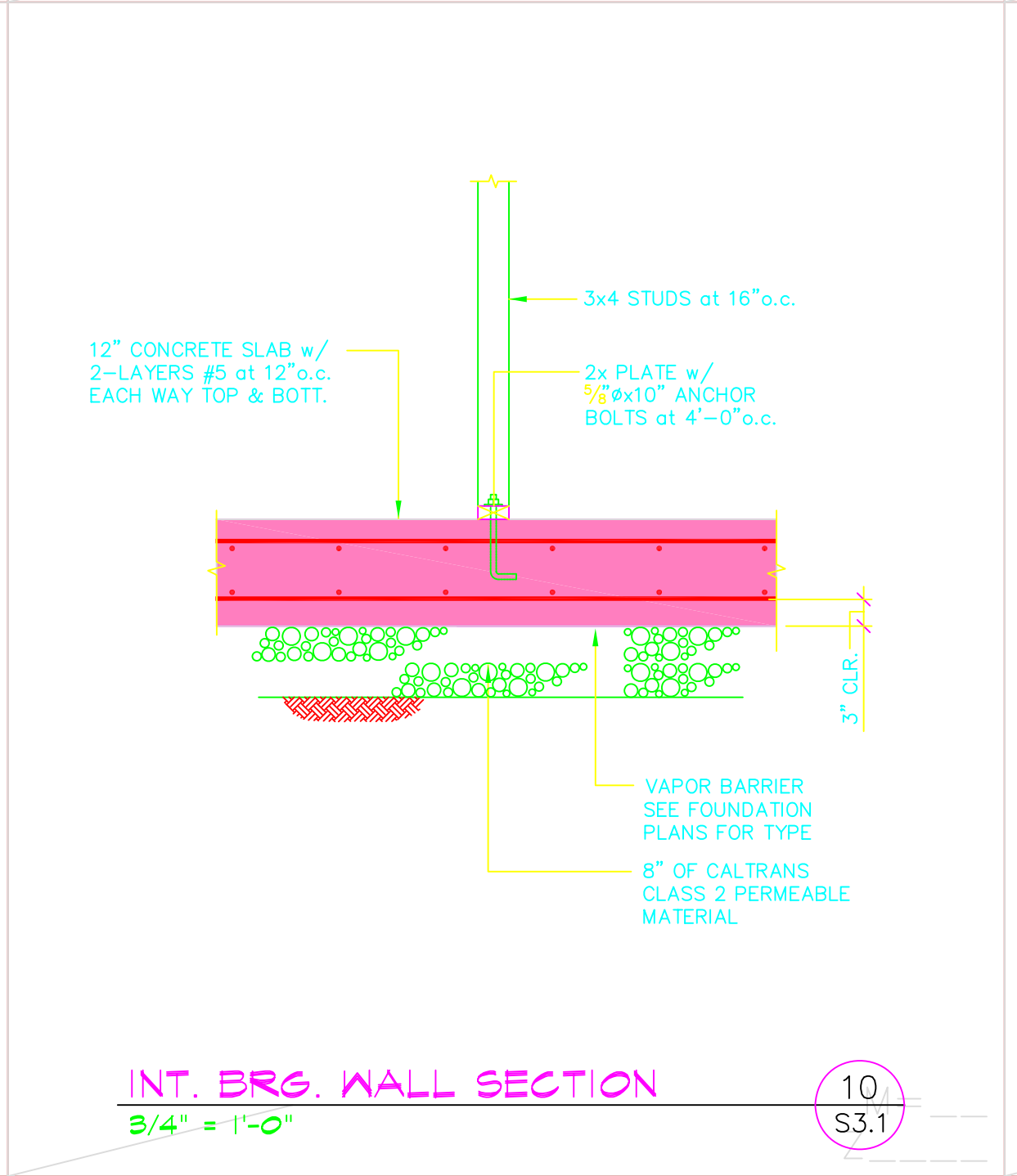
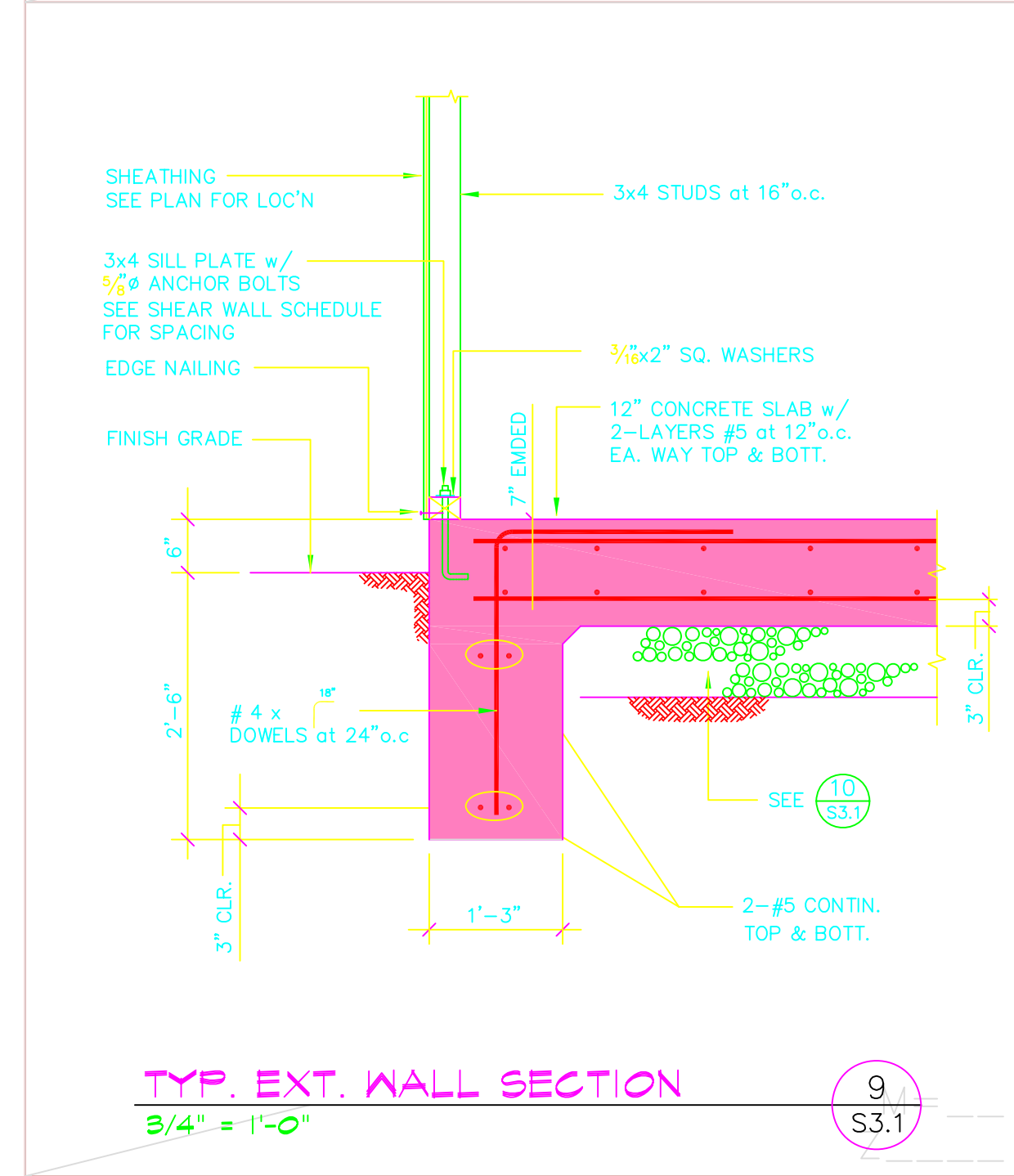
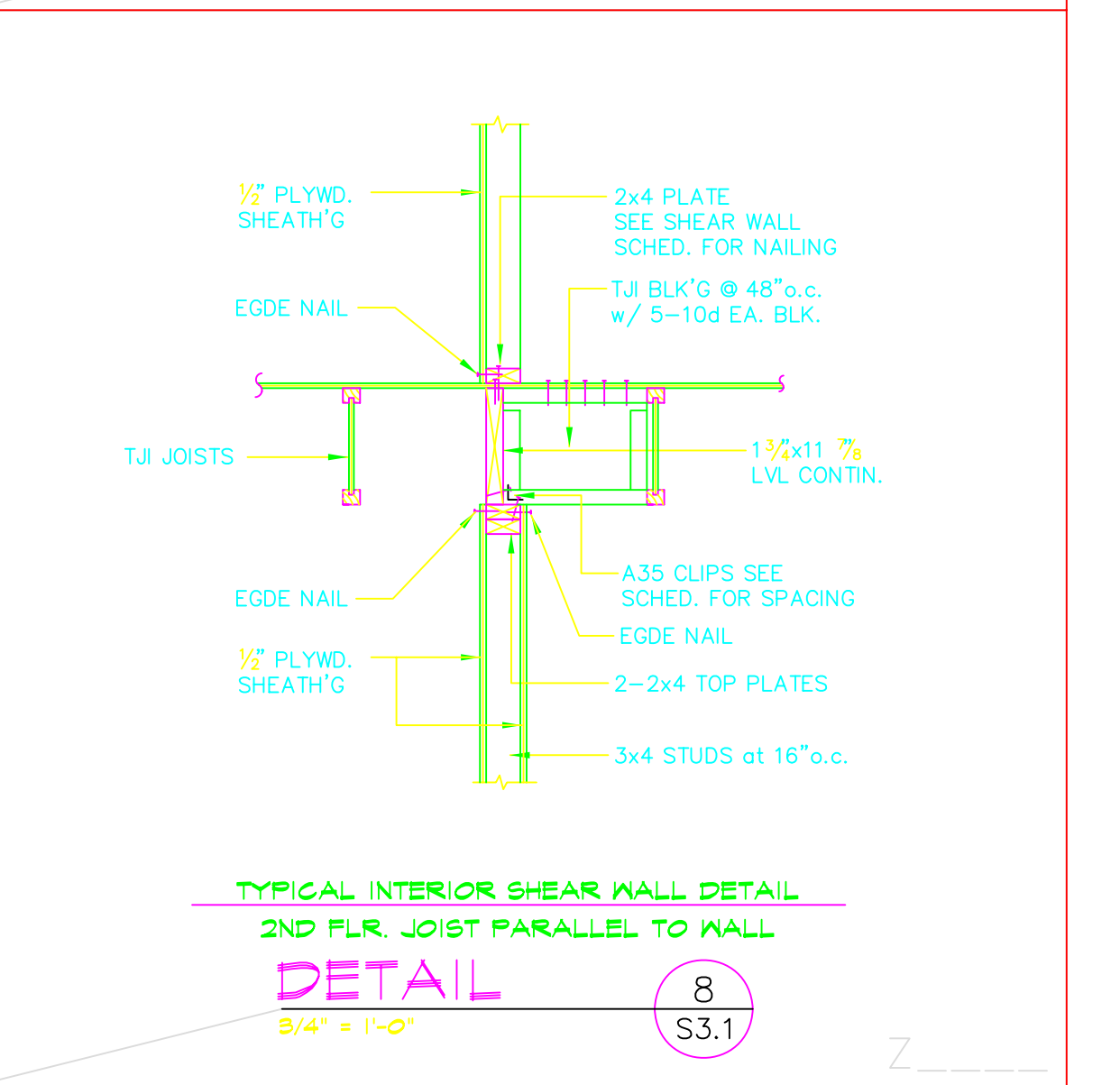
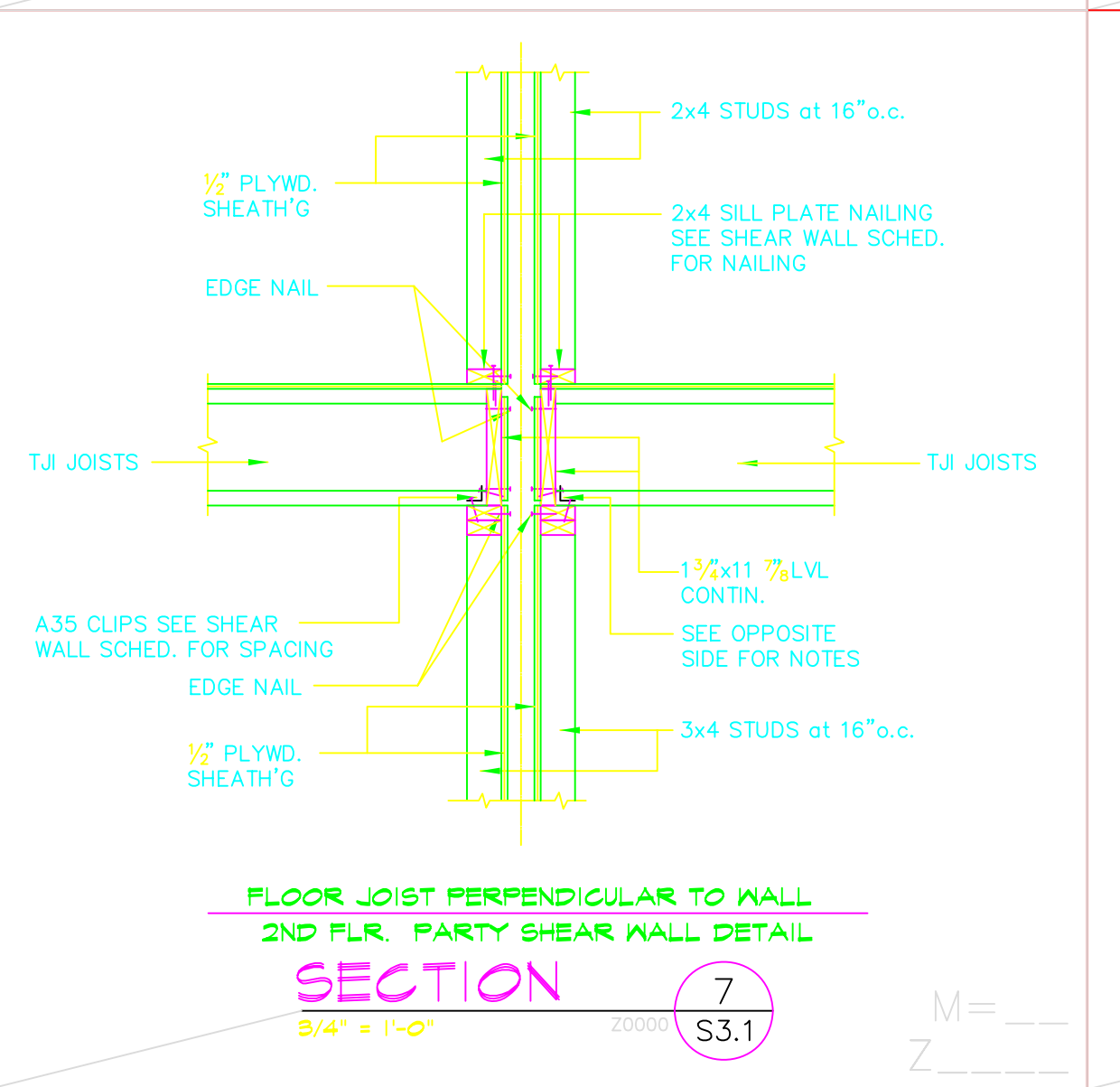
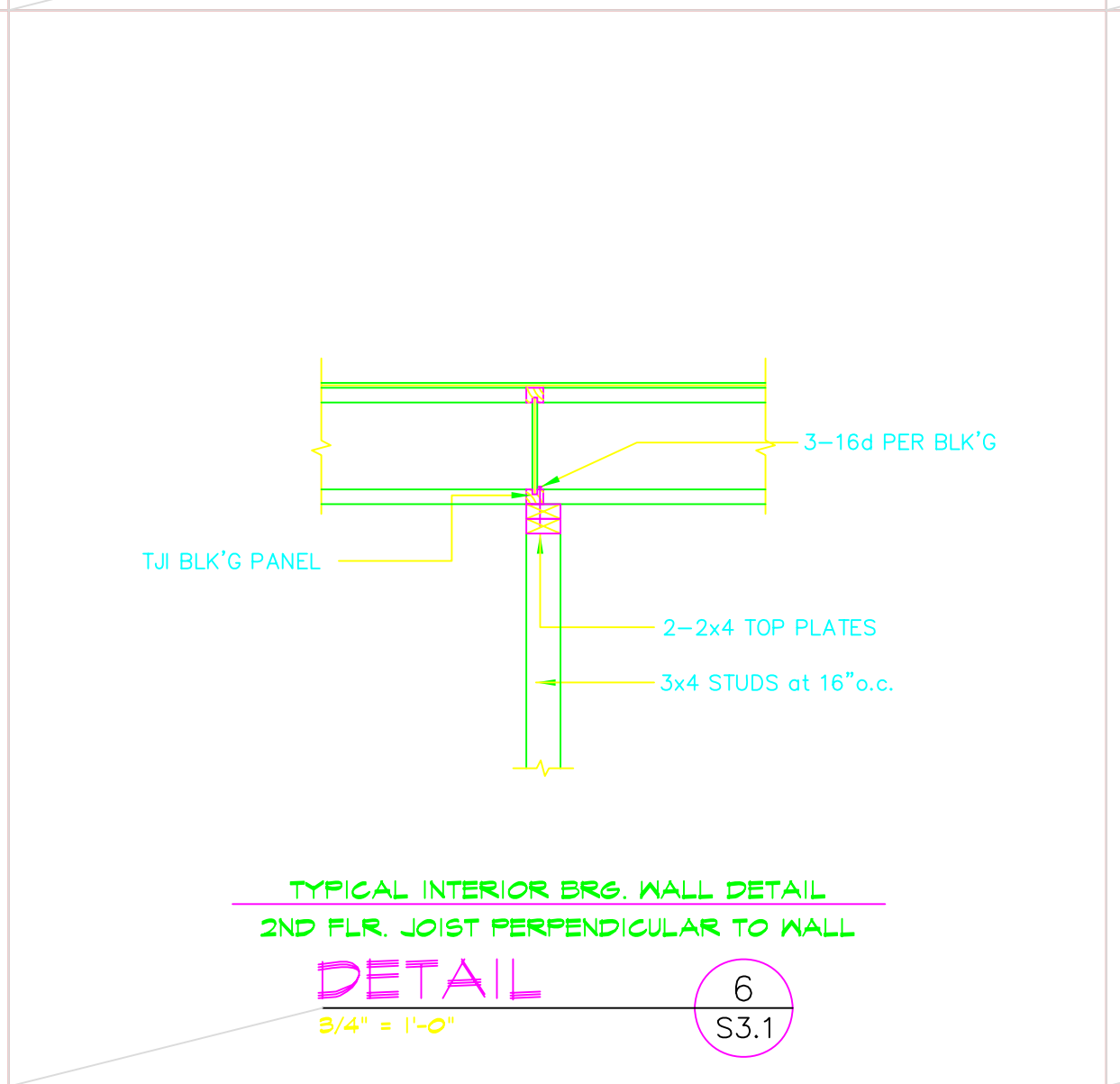
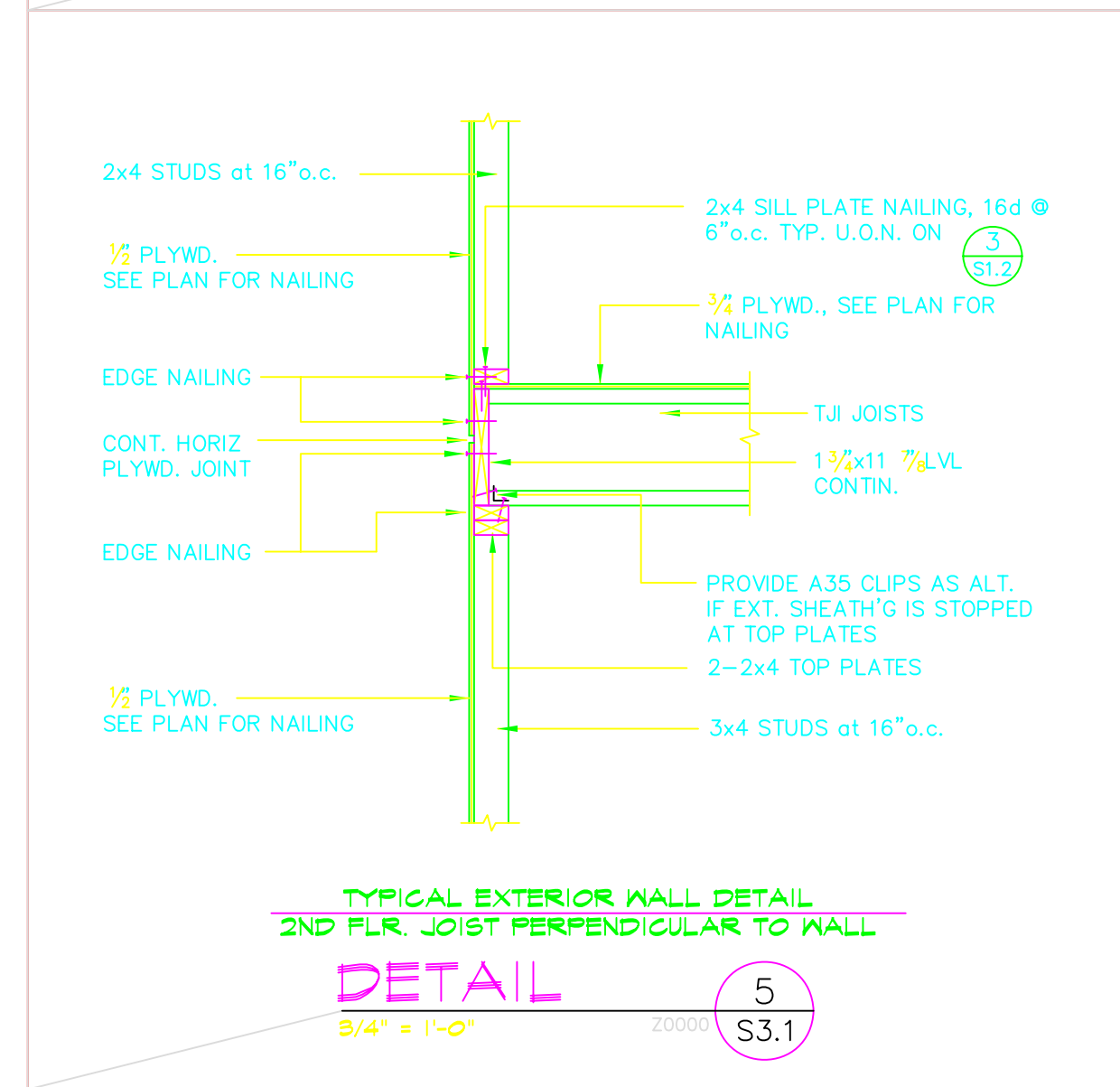
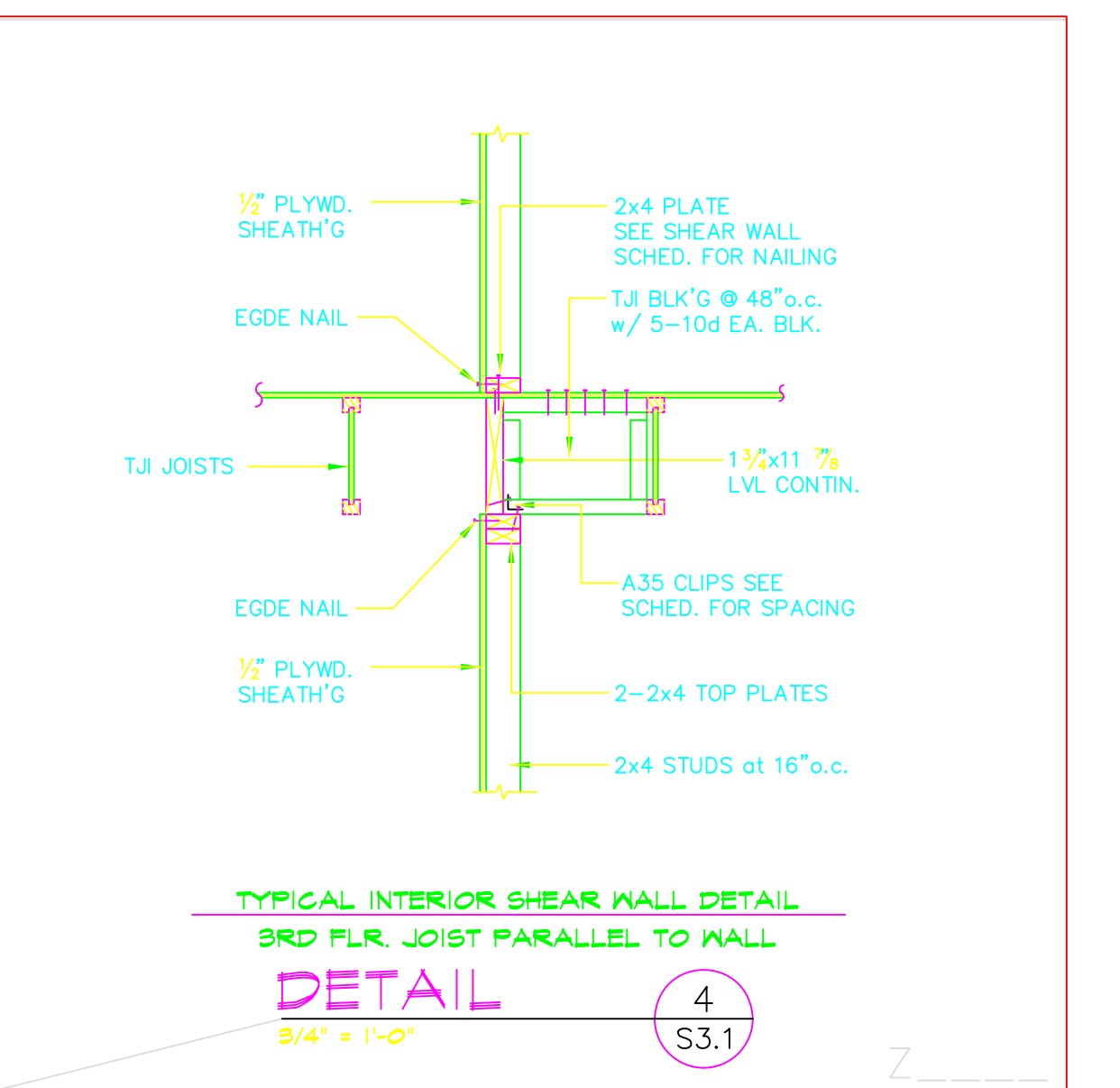
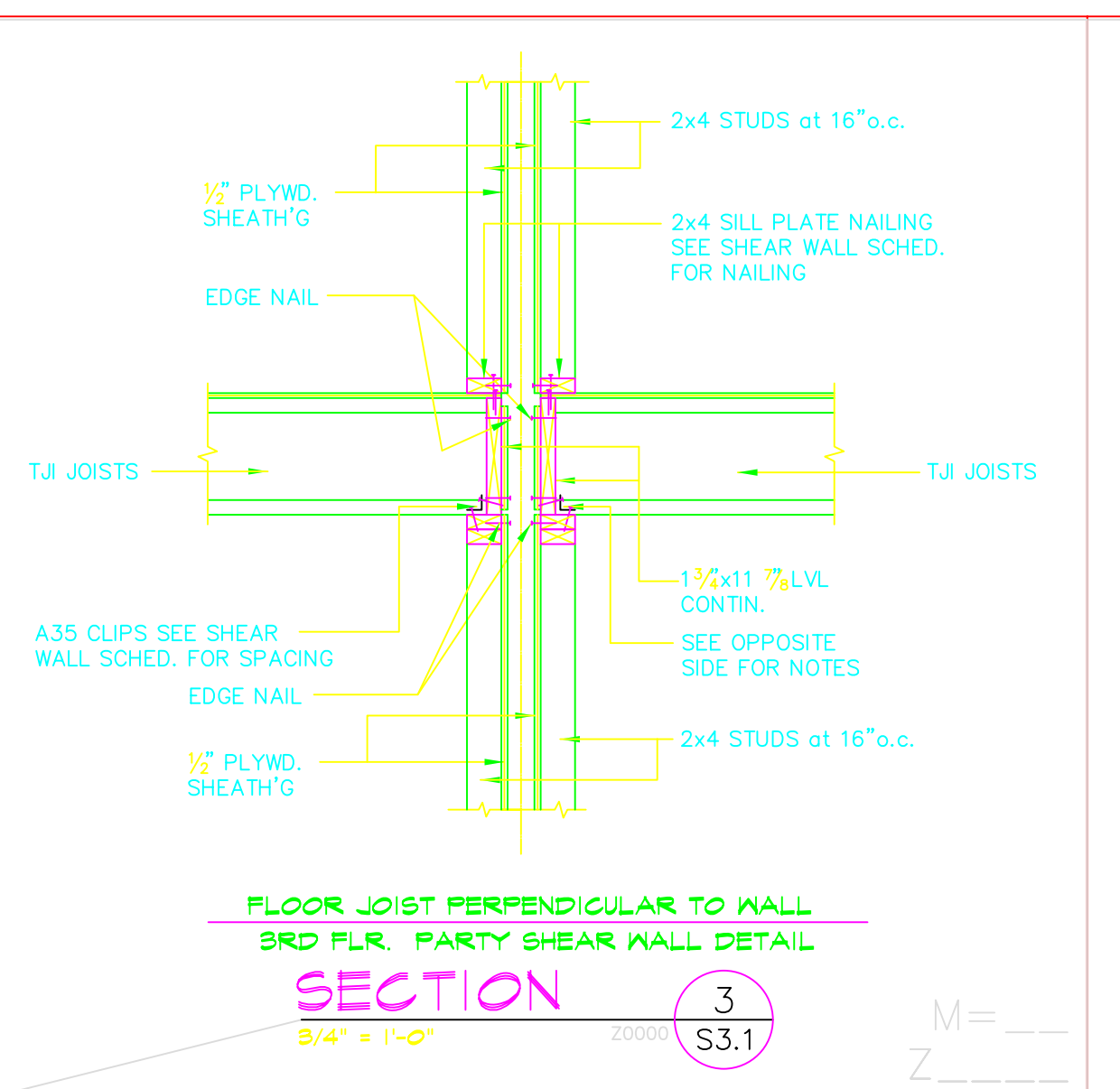
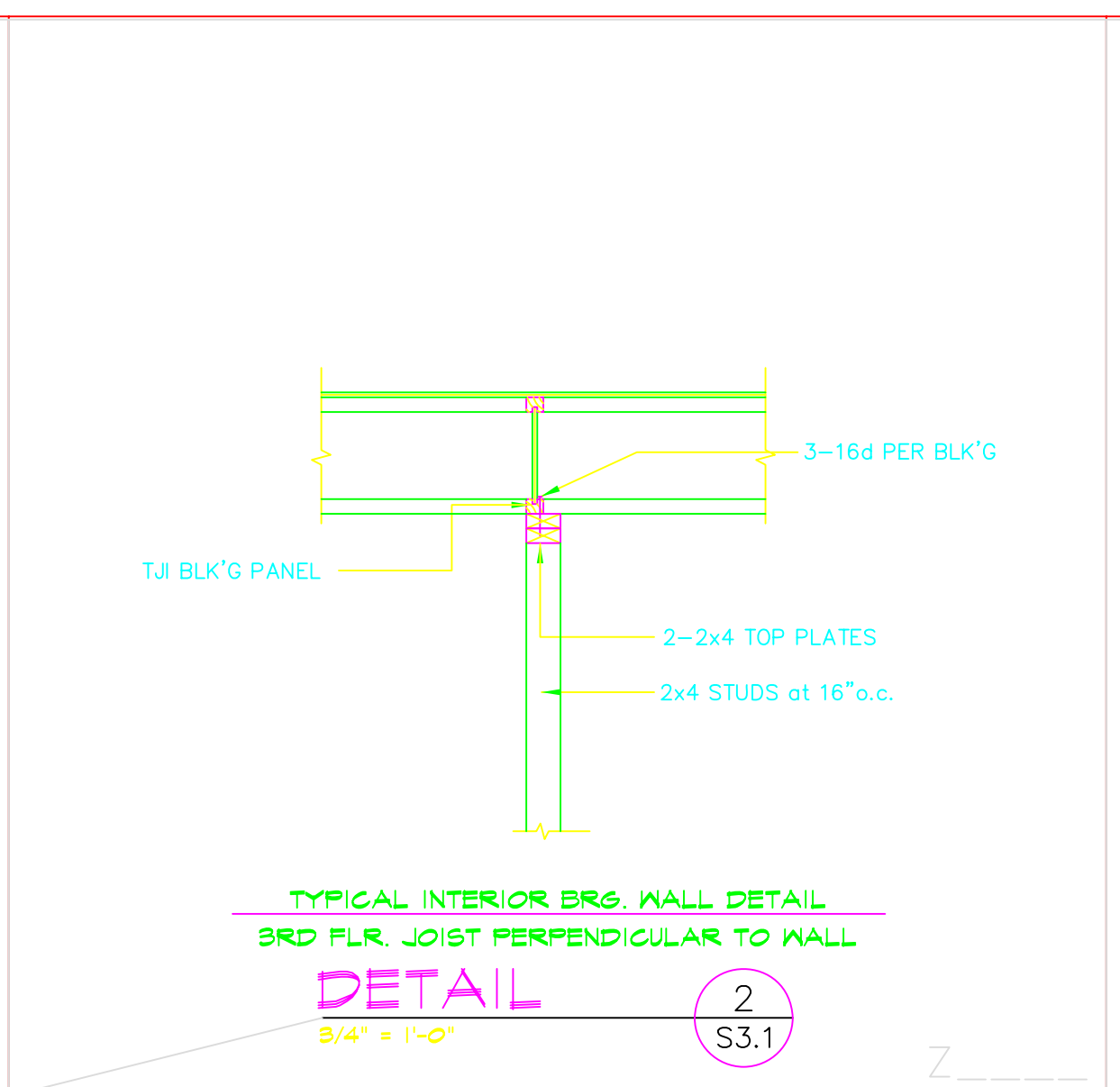
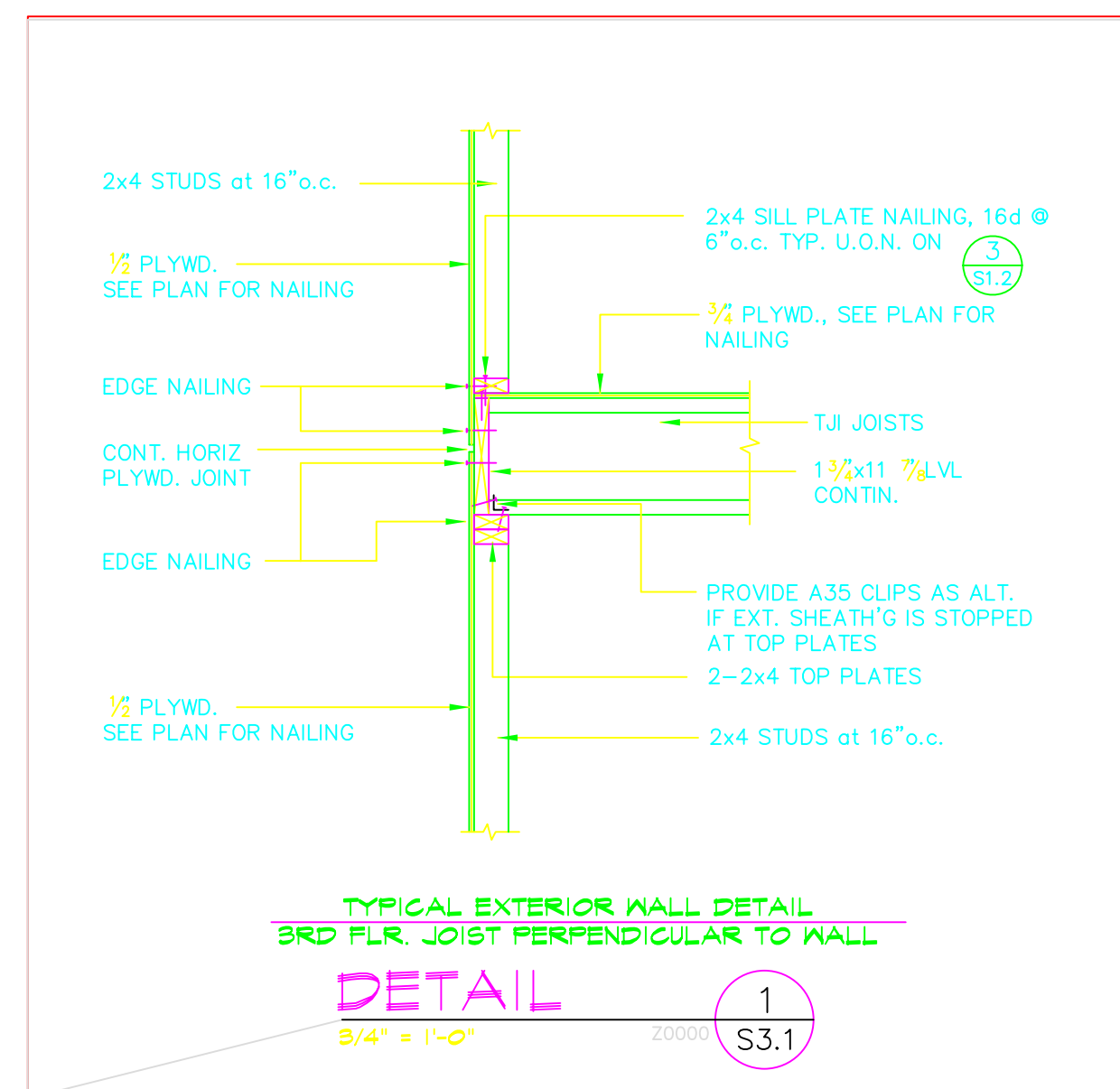

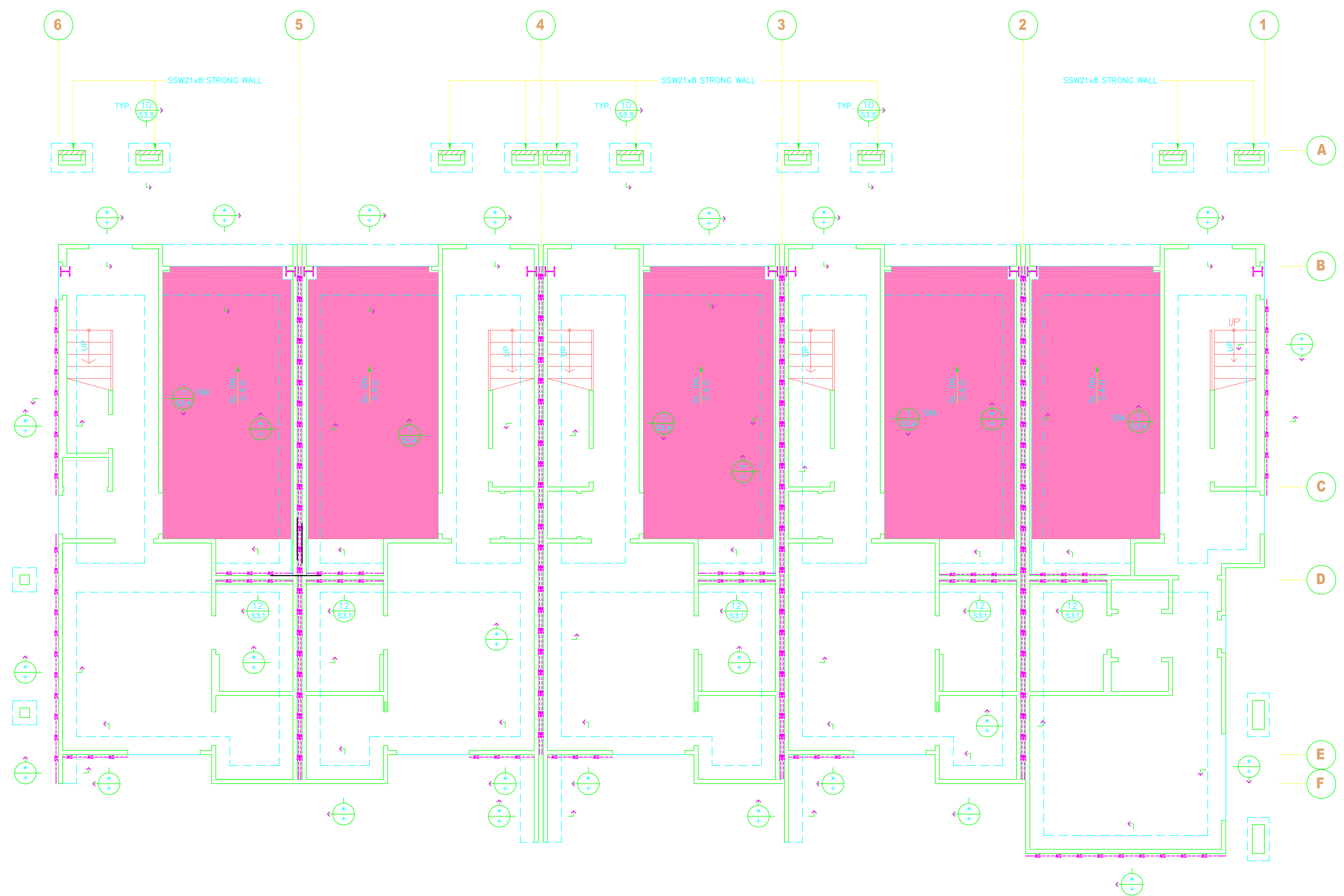

FOUNDATION NOTES:

1. VERIFY ALL DIMENSIONS WITH ARCHITECTURAL DRAWINGS PRIOR TO THE START OF CONSTRUCTION
2. REFER TO ARCH. DWGS. FOR TOP OF SLAB ELEVATION LOCATION & EXTENT OF ALL SLAB DEPRESSIONS, FLOOR DRAINS, SLOPES, ETC.
3. ALL WALLS SHOWN FOR THE FOUNDATION PLAN ARE THE 1ST. FLOOR ARCH. FLOOR PLAN WHICH IS ABOVE THE FOUNDATION
4. THE TIE-DOWNS SHOWN ON PLANS OCCURS AT THE SILL PLATE ABOVE THE SLAB.
5. S.A.D FOR CRICKET CONFIGURATION FOR SLOPES AT PATIO SLAB

LEGEND:

1. DENOTES ~8" SHEATHING WITH 10d EDGE NAILING AT ONE SIDE OF WALL. SEE SHEAR WALL SCHED. (3/ST.2)
2. DENOTES MST48 TIE STRAP FROM SHEAR WALL ABOVE THE REFERENCED LEVEL SEE (6/ST.1)
3. DENOTES HDU8 HOLD-DOWN FROM STRONGWALL ABOVE THE REFERENCED LEVEL
4. DENOTES HDU8 HOLD-DOWN FROM SHEAR WALL ABOVE THE REFERENCED LEVEL. SEE (9/ST.1)
5. DENOTES HHD011 HOLD-DOWN FROM SHEAR WALL ABOVE THE REFERENCED LEVEL SEE (9/ST.1) (1/ST.6)
6. DENOTES 2-HHD014 HOLD-DOWN FROM SHEAR WALL ABOVE THE 2nd FLOOR TO MOMENT FRAME SEE (2/ST.6) (2/ST.6)
7. DENOTES POST UNDER BEAM U.O.N., SEE (8/ST.2) (12/ST.2)
 4x4 POST FOR 4x AND 3~2"x GLU-LAM BEAMS
 4x6 POST FOR 6x AND 5 1/4"x PSL BEAMS
 4x8 POST FOR 6~C"x GLU-LAM BEAMS
 4x10 POST FOR 8~C"x GLU-LAM BEAMS
8. DENOTES TIE STRAPS FOR SHEAR WALLS LESS THAN 4'-6" SEE (1/ST.3)

NOTE: WHERE 2x6 & 2x8 STUD WALLS OCCURS, THE POSTS UNDER BEAMS SHALL BE INCREASED TO THE WIDTH OF THE STUD WALL

SALISBURY VILLAGE

LOCATION
 SALISBURY ST.
 OAKLAND, CALIFORNIA
 PROJECT PHASE: STRUCTURAL JOB NO. 95324

SCALE: AS SHOWN
 DATE: _____
 ISSUES / REVISIONS

FOUNDATION PLAN
 1/4" = 1'-0"

APPENDIX B

HEALTH & SAFETY PLAN

HEALTH AND SAFETY PLAN

AT
2145 35TH AVENUE
OAKLAND, CALIFORNIA 94601

PREPARED FOR:
SALISBURY AVENUE ASSOCIATES LLC PROJECT

SUBMITTED BY



1485 BAYSHORE BOULEVARD, SUITE 374
SAN FRANCISCO, CA 94124

SEPTEMBER 2016

EMERGENCY SERVICES

FACILITY / LOCATION

TELEPHONE

Emergency Situation911

HIGHLAND HOSPITAL AND CLINICS

Driving directions to 1411 E 31st St, Oakland, CA 94602

3D2D



2145 35th Ave
Oakland, CA 94601

- 1. Head **southwest** on **35th Ave** toward **Galindo St** 0.3 mi
- 2. Turn right onto **Foothill Blvd** 0.5 mi
- 3. Slight right onto **E 20th St** 0.4 mi
- 4. Turn right onto **23rd Ave** 0.8 mi
- 5. Turn left onto **E 31st St**
Destination will be on the left 0.4 mi



1411 E 31st St
Oakland, CA 94602

Office of Emergency Services

(800) 852-7550

USA Dig Alert

(800) 227-2600

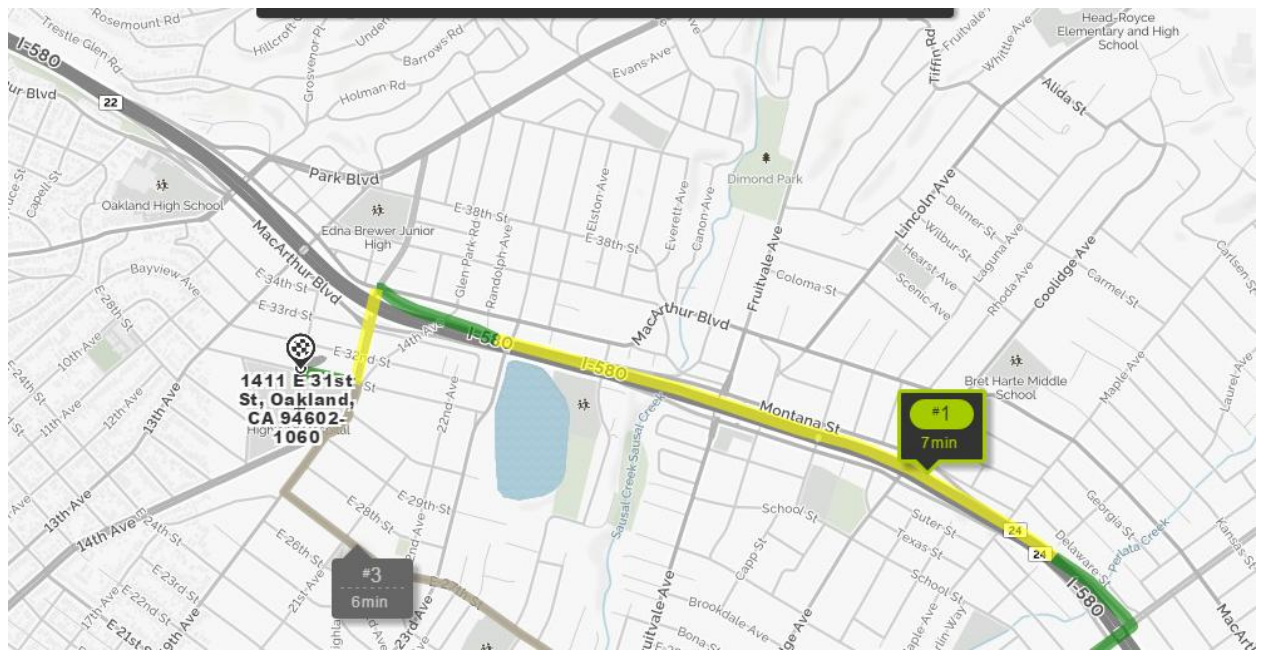

Contents

1.0	PURPOSE OF HEALTH & SAFETY PLAN	1
2.0	SCOPE OF WORK	1
3.0	SITE SAFETY AUTHORITY AND COMMUNICATION OF H&S ISSUES	1
4.0	HAZARD IDENTIFICATION.....	4
5.0	HAZARD REDUCTION.....	4
5.1	General Safety Rules	5
5.2	Heavy Equipment.....	5
5.3	Overhead Lines and Underground Utilities	6
5.4	Drilling	6
5.5	Site Evacuation.....	7
5.6	Spill of Hazardous Materials	7
5.7	Monitoring and Sampling.....	8
5.8	Vehicle Safety & Operation.....	9
5.9	Slipping, Tripping and Falling	9
5.10	Head, Foot, Eye, and Back Injuries.....	9
5.11	Falling Objects.....	10
5.12	Sharp Objects	10
5.13	Electrical Equipment	10
5.14	Noise Exposure.....	10
5.15	Heat Stress	10
5.16	Cold Exposure	11
5.17	Biological Hazards	11
6.0	PERSONAL PROTECTIVE EQUIPMENT	11
7.0	RESPIRATORY PROTECTION	12
8.0	AIR MONITORING.....	13
9.0	SITE SECURITY	14
10.0	SITE CONTROL.....	14
11.0	EMERGENCIES	16
11.1	Emergency Procedures	16
11.2	Evacuation Protocol.....	16

12.0	ACCIDENT REPORTING	17
13.0	PERSONNEL TRAINING	17
14.0	H&S PLAN AUTHORIZATION.....	19

Attachments

- A Safety Compliance Agreement
- B Emergency Services
- C Occupational Health Guidelines and Toxicological Information

1.0 PURPOSE OF HEALTH & SAFETY PLAN

The purpose of this Health & Safety Plan (H&S Plan) is to establish responsibilities, requirements, contingencies and procedures for the protection of personnel while performing excavation, drilling borings and soil and groundwater sampling.

During site work, the use of proper health and safety procedures, in accordance with applicable OSHA regulations shall be required. The procedures presented in this H&S Plan are intended to serve as guidelines. They are not a substitute for sound judgment by site personnel. If a situation arises where the H&S Plan requires revision, the appropriate changes will be made and communicated by the Site Safety Officer (SSO). Except in the case of emergency situations, no deviations from the plan may be implemented without the prior notification and approval of the Site Safety Officer (SSO).

2.0 SCOPE OF WORK

This H&S Plan is intended to address health and safety hazards associated with future soil excavation and disposal during future building construction. Also, this H&S Plan covers:

- 1) *Drilling using hand auger, direct push Geoprobe, or hollow stem auger.*
- 2) *Soil and Groundwater Sampling*

3.0 SITE SAFETY AUTHORITY AND COMMUNICATION OF H&S ISSUES

Contact information and names of authorized personnel are listed below. A description of responsibilities follows.

Role	Name	Contact Information
EEC Personnel		
EEC Project Director	Ronald Batiste President (or alternate)	Cell: 925-413-0188
EEC Project Safety Manager	Sami Malaeb Senior Environmental Engineer (or alternate)	Cell: (925) 858-9608
EEC Site Safety Officer (SSO)	Sami Malaeb Senior Environmental Engineer (or alternate)	Cell: (925) 858-9608
Contractor Personnel		

- Site Safety Officer (SSO)		Office TBD Cell TBD
- Site Safety Officer (SSO)		Office TBD Cell TBD

Project Director

- Responsible for the management and technical direction of all aspects of the project.
- Delegate responsibility for the operational implementation of the H&S Plan to Project Safety Manager and Site Safety Officer.

EEC Project Safety Manager

- Responsible for technical oversight of health and safety procedures and decisions related to work completed on the project.
- Ensures the completion of periodic site inspections.
- Conducts (or coordinates the completion of) incident investigations.
- Delegate responsibility for daily implementation of the H&S Plan and procedures to the Site Safety Officers.

Site Safety Officers (SSO) – Contractor Personnel

- Responsible for the daily implementation of the H&S procedures.
- Ensures H&S Plan is available onsite and that the plan is understood and signed by all personnel entering the site.
- Conducts (or coordinates the completion of) Tailgate Safety Meetings and ensures documentation of these meeting is available for review.
- Reminds site personnel of potential health hazards and appropriate procedures discussed in the H&S Plan, as needed.
- Communicates additional pertinent information whenever other health and safety matters need to be addressed.
- Implements emergency response procedures when necessary.

Assistant Site Safety Officer (Assistant SSO) – EEC & Contractor Personnel

- In the event the SSO is not on site, the Assistant SSO will assume the responsibilities of the SSO.

It is EEC’s intent to have either the SSO or Assistant SSO available onsite during work activities related to soil excavation and disposal.

Employees

- Responsible for understanding and complying with this H&S Plan.
- Are required to participate in briefings prior to commencement of site work (e.g., Tailgate Safety Meetings), as applicable.
- Must acknowledge an understanding of the H&S Plan by signing the “Safety Compliance Agreement” (See Attachment A).

Contractors

Client will hire contractors to apply their technical expertise to specific work tasks, such as excavation, sampling, and heavy equipment operation. Although client has a certain level of knowledge in these areas, the contractor is most knowledgeable of the hazards associated with their particular expertise. Therefore, client will rely heavily on the contractor to apply their technical expertise, safety knowledge and established safe work practices to protect against accidents, injury or illness.

For this reason, safety of contractor employees is primarily the responsibility of the contractor. Contractors are required to follow and operate within their company's health and safety program and policies. Contractors are to designate a company representative as their own Site Safety Officer. This individual shall monitor their employees and ensure safe working procedures are being followed. The contractor shall identify their Site Safety Officer and, if applicable, Assistant Safety Officer to the client in writing.

Contractors shall provide their own safety equipment and personal protective equipment. Contractors shall be ultimately responsible for ensuring their equipment is in proper working order and their employees are trained and medically fit to complete the work assigned to them. Upon request, contractors shall also provide evidence that personnel working at the site have received the necessary training and, if applicable, medical surveillance.

EEC or general contractor onsite has a definite influence over site activities and consequently health & safety issues. As mentioned, EEC expects contractors to apply their expertise, safety knowledge and established safe work practices when completing work tasks at the project site. EEC or general contractor onsite will exercise reasonable care to prevent and detect safety violations on the site. However, direct supervision of contractor employee safety is the responsibility of the contractor.

The requirements stated in this H&S Plan are not intended to replace existing programs and policies rather they are meant to expand upon them. This H&S Plan provides procedures for safety-related matters that may never emerge during site activities. Such matters may include: air monitoring for hazardous atmospheres, the use of respiratory protection, and persons entering hazardous excavations and/or confined spaces, etc. The contractor must inform EEC or general contractor onsite if a particular task exceeds day-to-day safety requirements and necessitates additional safety precautions to protect the employees performing the particular task. In such cases, EEC or general contractor onsite may dictate that additional safety precautions be implemented. In the event a discrepancy arises between contractor safety policies or procedures and those of EEC or general contractor onsite, the more stringent is to be implemented.

A copy of the H&S Plan will be made available to each designated Contractor Site Health and Safety Officer (SSO) prior to coming to the sites. Upon review or briefing of the H&S Plan, each contractor and their personnel working at the site will be required to sign the "Safety Compliance Agreement" (See Appendix A) to verify their understanding of the document.

Visitors

- ❑ All visitors should be encouraged to sign-in each time they enter the project site.
- ❑ At a minimum, authorized visitors will be provided a copy of basic site safety information. Upon request, a copy of this H&S Plan will be made available for review.
- ❑ Visitors should be escorted by an EEC or general contractor onsite, or designated contractor employee and should not be allowed to move about the site alone.

4.0 HAZARD IDENTIFICATION

Although this H&S Plan attempts to identify many of the hazards that may be encountered at the site, it is not intended to address every possible situation that may arise. Therefore, it is essential for all personnel working at the site to take responsibility for their own safety. If a situation or work task seems unsafe, stop work and notify your supervisor of the circumstances so the appropriate precautions can be taken before work begins. Supervisors are then responsible for notifying their SSO of the unsafe situation or condition

The following is a list of potential hazards and tasks associated with the activities planned for this site:

- ❑ Heavy equipment
- ❑ Overhead lines and Underground Utilities
- ❑ Drilling
- ❑ Monitoring and Sampling
- ❑ Excavation and Trenching
- ❑ Vehicle Safety and Operation
- ❑ Slipping, Tripping and Falling
- ❑ Head, Foot, Eye and Back Injuries
- ❑ Falling objects
- ❑ Sharp objects
- ❑ Electrical Equipment
- ❑ Welding Hazards
- ❑ Noise Exposure
- ❑ Heat Stress
- ❑ Cold Stress
- ❑ Biological Hazards

5.0 HAZARD REDUCTION

This section of the H&S Plan will present the general safety rules applicable to all persons working at the project site. The section will also discuss each of the hazards identified and provide guidelines and procedures necessary to avoid injury or illness.

Personnel are required to exercise reasonable caution at all times during work activities. Failure to follow safety protocols and/or continued negligence of health and safety policies will result in expulsion of a worker from the site and may result in termination of employment.

5.1 General Safety Rules

- ❑ Horseplay, fighting, gambling, possession of firearms, alcoholic beverages, illegal drugs, or usage of unauthorized medically prescribed drugs are not permitted.
- ❑ Work shall be well planned and supervised to prevent injuries. Supervisors shall assure that employees observe and obey safety rules and regulations.
- ❑ An employee reporting for work who, in the opinion of his supervisor, is unable to perform his assigned duties in a safe and reasonable manner shall not be allowed on the job.
- ❑ No employee shall be assigned a task without first having been instructed on proper methods, including safety training, of carrying out the task. Any employee who feels they have not received proper instruction shall notify their supervisor prior to carrying out the task.
- ❑ Injuries and accidents shall be reported immediately to the immediate supervisor, who will then report it to the SSO.
- ❑ There shall be no consumption of food or drink in operational areas of the site. Hands should be thoroughly cleansed prior to eating.
- ❑ Smoking is not permitted on the site.
- ❑ When personnel are conducting hazardous operations, there shall be at least one other person (buddy system) on duty in the immediate area as a backup in case of emergency.

5.2 Heavy Equipment

The operation and use of heavy equipment presents the greatest potential for injury to personnel. Heavy equipment utilized at the site may include trucks and drill rigs. Common sense and good judgment must be practiced when working around heavy equipment and machinery. To minimize hazards, designated routes and specific traffic patterns will be established.

Only equipment that is in safe working order will be used. Only qualified personnel will be allowed to operate heavy equipment. Contractors will supply proof of qualifications to operate the equipment, upon request.

Heavy equipment will use spotters for backing. Those crew members directly involved in spotting for the operator will be the only personnel allowed within the operating radius of the heavy equipment. Other personnel will remain at a safe distance from these operations. If personnel need to approach heavy equipment during operation, they will observe the following protocols: make eye contact with the operator, signal the operator to cease heavy equipment activity, and then approach the equipment to inform operator of intentions.

Operators of heavy equipment should abide by the following guidelines:

- ❑ Before starting any heavy equipment, conduct a visual inspection and walk around. Check tires and equipment for any visible malfunctions.
- ❑ Check hand and foot holds before mounting equipment. Mount and dismount in the same manner using handrails and footholds.
- ❑ Fasten seat belts and follow equipment startup procedure.
- ❑ Test brakes, steering and clutches.
- ❑ Use extreme caution around power and water lines. Always check with supervisor about underground utility and gas lines.
- ❑ When using outriggers on a backhoe, make sure they are planted on solid ground to prevent tipping over. Coworkers in the area of the backhoe should stand clear of the radius of the boom and the bucket.
- ❑ In case of a breakdown or an incident, lower all hydraulic systems, set brakes, shut down equipment and notify your supervisor.

5.3 Overhead Lines and Underground Utilities

When operating heavy equipment near overhead power lines, care will be taken to ensure that elevated portions of the equipment maintain a distance of at least 10 feet from high voltage lines of 50,000 volts or less. See article 86, Title 8, High Voltage Electrical Safety Orders for minimum clearance of high voltage lines in excess of 50,000 volts.

If subsurface work (excavations, drilling or potholing) is performed, a USA utility mark-out is required to mark/clear underground utilities prior to work. It is recommended that the first 5 feet of any subsurface operation be excavated using an air-knife or hand auger to ensure clearance of underground utility lines. Special precautions must be made to identify the location of gas lines before excavation or earthmoving operations begin. A private utility locator will be used in most cases as well as USA mark outs.

5.4 Drilling

- ❑ Drilling activities will be monitored by an organic gas meter.
- ❑ Have an active USA ticket.
- ❑ A private locator will be used as well as USA.
- ❑ Drilling of the first five feet below surface will be conducted by a hand auger.
- ❑ Drilling crew should be alert that a drill auger has the potential of spark against a rock or metal causing a fire in the boring. Fires should be extinguished by covering the boring with earth material (preferably using heavy equipment).
- ❑ Fire extinguishers should be on hand during drilling.
- ❑ No smoking shall be permitted within 50 feet of a boring.
- ❑ The number of persons working near a boring should be kept to a minimum. However, there should be sufficient people nearby to summons help if necessary.
- ❑ If boring in or near refuse:

- Be aware of the less stable conditions. Refuse and cover soil are prone to be unstable and may cause the side of the boring to fail at any time.
 - Be aware that there is the potential of encountering hazardous materials such as unknown chemicals, munitions, asbestos, compressed gas cylinders, biomedical wastes and radioactive wastes. If any such materials are encountered - stop work, shut down equipment, leave the area and notify the supervisor and SSO immediately.
- All borings shall be capped at the end of each day.

5.5 Site Evacuation

The SSO will designate evacuation routes and refuge areas to be used in the event of a site emergency.

Site personnel will stay upwind from vapors or smoke and up gradient from spills. If workers are in an Exclusion or Contamination Reduction Zone at the start of an emergency, they should exit through the established decontamination corridors, if possible. If evacuation cannot be done through an established decontamination area, site personnel will go to the nearest safe location and remove chemically-affected clothing there or, if possible, leave it near the Exclusion Zone. Personnel will assemble at the predetermined refuge following evacuation and decontamination. The SSO, or designated representative, will count and identify site personnel to verify that all have been evacuated safely.

5.6 Spill of Hazardous Materials

If a hazardous material spill occurs, site personnel should locate the source of the spill and determine the hazard to the health and safety of site workers and the public. Attempts to stop or reduce the flow should only be performed if it can be done without risk to personnel.

Isolate the spill area and do not allow entry by unauthorized personnel. De-energize sources of ignition within 100 feet of the spill, including vehicle engines. Should a spill be of the nature or extent that it cannot be safely contained, or poses an imminent threat to human health or the environment, an emergency cleanup contractor or trained workers onsite will be called out as soon as possible. Spill containment measures listed below are examples of responses to spills:

- Right or rotate containers to stop the flow of liquids. This step may be accomplished as soon as the spill or leak occurs, providing it is safe to do so;
- Sorbent pads, booms, or absorbent materials may be used to dike or berm materials, subject to flow, and to solidify liquids;
- Sorbent pads, soil, or booms, if used, must be placed in appropriate containers after use, pending profiling and disposal;
- Contaminated tools and equipment shall be collected for subsequent cleaning or disposal.

Employees cleaning up debris and waste in the exclusion zone/ regulated area where respirators are required shall wear respirators which are selected, used, and fitted by a qualified health and safety personnel approved by OSHA.

If the spill or discharge is reportable, and/or human health or the environment is threatened, notify the PM, followed by the National Response Center, Contra Costa County Environmental Health Department, Richmond Police and Fire Department non-emergency line. Spills or leaks, regardless of their quantity will be reported to the PM immediately following discovery. A follow-up written report will be submitted to the PM within seven (7) days after the initial report. The report will include the following:

- A description of the material spilled including identity and quantity. Photographs showing the location and extent of the spill;
- A statement as to whether the amount spilled is EPA/State reportable and when and to whom it was reported;
- Exact time and location of the spill, including a description of the area involved; and
- Containment procedure initiated and a full description of the cleanup measures taken, or to be taken, including disposal location of the spill residue.

5.7 Monitoring and Sampling

Monitoring and sampling tasks consist of an employee collecting samples and/or monitoring conditions with detection instruments and measurement devices at various locations throughout the site. Activities will include reading volatile organic gases by using an organic vapor meter.

Workers who must come in direct contact with known or suspected chemicals (in soil, water, air, gas, etc.) are required to wear protective gloves and other PPE, as needed, to reduce the potential for exposure. Safety glasses will be worn whenever the potential for splashing of chemicals into the eyes exists.

All the same general rules and applicable safety requirements stated in this H&S Plan apply to personnel performing monitoring and sampling activities. The following are typical safety hazards and associated precautions encountered for this work:

- Uneven terrain and steep slopes - Pedestrians and drivers shall exercise greater than normal caution while working in uneven terrain or steep slope areas.
- Look for obstructions and holes on ground surface, and slippery conditions when water exists.
- Workers shall use the appropriate type of vehicle for access to the sampling locations.
- Traffic - Workers involved in sampling activities shall:
 - Be alert for traffic
 - Wear orange vests
- Equipment - Workers shall be thoroughly familiar with the operating and safety procedures for equipment used in sampling activities.

Storm water

The chemical concentrations present in water samples collected after a storm are not anticipated to pose a threat to human health. No special hazard reduction measures are required. Follow the general safety rules, be aware of heavy equipment, follow traffic routes and ensure others are aware of your location at all times.

5.8 Vehicle Safety & Operation

- ❑ Drivers operating vehicles offsite must have a valid California driver's license in their possession. The California vehicle code shall be strictly observed.
- ❑ Heavy construction equipment has the right-of-way over regular vehicles and pedestrians.
- ❑ Before driving the vehicle, conduct a routine check to assure that it is in proper operating condition. Pay special attention to the condition of the brakes, lights (including brake lights and turn signals), steering, windshield wipers, tires, and lugs.
- ❑ Report immediately any deficiencies observed or suspected in the vehicle to your supervisor. No unsafe vehicles shall be operated.
- ❑ Drivers and passengers, in all vehicles, will fasten seat belts before vehicle is set in motion.
- ❑ Any posted onsite speed limits shall be observed; where not posted, the onsite speed limit is 15 miles per hour.
- ❑ Extra caution shall be exercised when backing. If rear vision is obstructed, take time to walk around the vehicle or have someone guide you back. Vehicles or equipment shall not be moved until the driver or operator has walked around the vehicle or equipment.
- ❑ Personnel are not allowed to jump off or onto any moving pickup or truck.
- ❑ Tailgate shall be locked when carrying personnel in the bed of the truck.
- ❑ Vehicles shall be safely parked with hand brake secured when left unattended.

5.9 Slipping, Tripping and Falling

Besides promoting orderliness and cleanliness, good housekeeping practices helps to eliminate accidents and fire hazards. Slips, trips and falls due to poor housekeeping are at the root of many work related accidents. For this reason, work areas are to be kept neat and orderly so as to prevent unnecessary injuries.

Remember to maintain sure footing on all surfaces. The use of a safety harnesses is required for personnel working 6 feet or more above any surface that does not have handrails (e.g., riding on man lifts).

5.10 Head, Foot, Eye, and Back Injuries

Hard hats are required to be worn when in the vicinity of any operating equipment or machinery (including drilling rigs and soil/rock trucks) and when any overhead or lateral

obstruction or hazard exists. Safety boots will be worn during all site operations. Safety glasses are required when there is risk of hazardous substances or flying particles getting into eyes.

To avoid back injuries, personnel are to use proper equipment and lifting techniques for manual material handling. Never carry a load you cannot see over or around. When lifting, caution should be exercised. If the object to be lifted is too heavy, get help. If two or more workers carry a load, designate one worker to give signals. Whenever possible, mechanical equipment shall be used for lifting in preference to lifting by hand.

5.11 Falling Objects

Equipment and material will be lowered to the ground "slowly" using a grapple and/or skip bucket. Personnel shall not work under this equipment; nor shall personnel other than the operator ride on the equipment.

5.12 Sharp Objects

Nails, wires, saws, and cutting equipment pose potential hazards such as cuts and punctures during site work. Only appropriate work tools are to be used. Personnel are required to exercise caution, and should wear leather work gloves and safety glasses when handling or operating cutting tools, saws, and other sharp objects. A consistent housekeeping effort at the site will also help to reduce hazards from sharp objects.

5.13 Electrical Equipment

Only authorized personnel shall perform electrical and instrumentation work.

In order to prevent accidents caused by electric shock, electrical connections will be inspected before use. Equipment found to have frayed wiring or loose connections is to be shut down and locked out until a qualified electrician has affected repairs. Electrical equipment will be de-energized, tested and locked out before any electrical work is started. Equipment will be properly grounded prior to and during work.

In addition, ground fault circuit interrupters (GFCIs) will be installed whenever possible in each circuit between the power source and tool. In the event that generators are used to supply power, they will be equipped with GFCIs.

5.14 Noise Exposure

High-noise areas are where noise levels exceed 85 dbA. If high noise equipment or operations are introduced to the work site, hearing protection (ear plugs or ear muffs) will be required.

5.15 Heat Stress

Heat stress is a potential hazard associated with high ambient temperatures, use of protective clothing, heavy physical labor and/or a combination thereof. This condition can result in heat rash, heat cramps, heat exhaustion, and/or heat stroke. It can impair

worker coordination and judgment and directly impact health and safety. Personnel are to drink plenty of water and take breaks (in shaded rest areas) as needed to help prevent heat stress. As part of the Buddy System, personnel should watch for signs and symptoms of heat stress in coworkers as well as themselves.

5.16 Cold Exposure

To guard against cold injury (frostbite and hypothermia), which is a danger when the temperature and wind-chill factor are low, employees will wear appropriate clothing, have warm shelter readily available, and maintain carefully scheduled work and rest periods.

5.17 Biological Hazards

Care should be taken when walking throughout the site. Look for snakes especially in undisturbed areas or where no construction activity has previously occurred. If bitten by a snake, personnel should notify their supervisor to obtain prompt medical care.

Insects, including bees, wasps and spiders are found at all sites. Care should be taken when working in areas where these insects are prevalent. Be sure to check for the presence of spiders, particularly black widows, when completing work in dark, cool previously undisturbed areas. Notify your supervisor promptly so that first aid and/or medical care can be provided, as necessary. If possible, try to identify the insect that caused the bite.

"Universal Precautions" (e.g., wearing latex gloves) must be taken any time there is potential for exposure to human blood, such as when an employee renders first aid to a coworker.

6.0 PERSONAL PROTECTIVE EQUIPMENT

Personnel are required to wear PPE appropriate for the task and anticipated exposure to known hazards. Selection of PPE will be based on hazard assessment, task performance, and air monitoring. Based on the history of this site, the initial level of protection will be Level D. At a minimum, Level D PPE will consist of the following:

- ❑ Hardhat - when in the vicinity of any operating equipment or machinery (including drilling rigs and soil/rock trucks) and when any overhead or lateral obstruction or hazard exists.
- ❑ Safety shoes/boots with steel toe and shank - at all times in work area
- ❑ Safety glasses, splash goggles or face shield - when there is risk of hazardous substances or flying particles getting into eyes
- ❑ Ear plugs / hearing protection - when high-noise equipment is in operation
- ❑ Gloves: chemical-resistant - when coming into contact with contaminated soil or water.
- ❑ Traffic safety vest

Site personnel also should be prepared with the following items:

- Tyvek coveralls and other suitable protective clothing
- Leather work gloves and back brace/lifting belt
- Respirators (if applicable - see Section 8.0, Respiratory Protection).

7.0 RESPIRATORY PROTECTION

Respiratory protection is mandatory if workers are required to complete tasks within a hazardous atmosphere. According to OSHA, a hazardous atmosphere is defined as:

- When concentration of a known contaminant is greater than the permissible exposure limit (PEL).

Hazardous atmospheres are not anticipated during day-to-day operations at the site. Therefore, most tasks to be completed may not require respiratory protection. However since the possibility of hazardous atmospheres does exist, air monitoring will be required to verify the presence or absence of a hazardous atmosphere. Air monitoring is to be conducted whenever a situation or condition arises that could reasonably result in a hazardous atmosphere. Again, respiratory protection is mandatory if workers are required to complete tasks within a hazardous atmosphere.

Use of Air-Purifying Gas/Vapor Respirators

Air-purifying gas/vapor respirators will be required at the site. However, hydrocarbons or other chemicals present in the subsurface have the potential to result in hazardous atmospheres. Air monitoring will be required to verify the presence or absence of a hazardous gas/vapor atmosphere whenever a situation or condition arises that could reasonably result in a hazardous atmosphere.

Air purifying respirators (APRs) with chemical cartridges will be used for acid gas/organic solvent vapors under the following conditions:

- If the oxygen concentration is between 19.5% and 23.5%.
- If chemical contaminants have been identified.
- The toxic concentrations are known and the respirator cartridges are effective in removing the contaminants.
- The respirator and cartridges are NIOSH/MSHA approved.
- The contaminants have noticeable warning qualities such as odor and visibility characteristics including color.

In the event workers are required to wear air-purifying gas/vapor respirators, the following requirements must be met:

- The SSO must verify that workers are:
 - Medically approved (within one year) to use respiratory protection.
 - Fit-tested for the specific respirator to be used.
 - Trained in the proper use and limitations of the respirator to be used.

- ❑ Contractors must provide proof of the above to the SSO before any air-purifying gas/vapor respirators may be used.
- ❑ If an employee or contractor has not cleared by the SSO to use a respirator, they will not be assigned tasks that may potentially expose them to contaminants.
- ❑ Personnel with interfering facial hair are not permitted to wear respirators and shall not be permitted in areas where respiratory protection is required.

Use of Air-Supplied Respirators

Air-supplied respirators, such as SCBA or airline, full-face respiratory protection, are not anticipated to be required at the site. This level of respiratory protection is utilized in oxygen deficient atmospheres or atmospheres considered to be at or above immediately dangerous to life and health (IDLH) levels. These conditions will only occur in rare, if any, circumstances such as confined space entry or emergency situations. The use of air-supplied respiratory protection is not permitted without approval and guidance from the Project Safety Manager.

8.0 AIR MONITORING

Monitoring will be conducted as needed to characterize airborne contaminant levels. The potential hazards associated with the presence of hydrocarbons include personnel exposure to chemicals (Attachment C).

Air monitoring will be performed to assess airborne contaminant levels onsite and to evaluate the need for respiratory protection. The SSO will check to see that air-monitoring equipment brought onsite is properly calibrated prior to operation and recalibrated during the course of the day, if necessary.

Air monitoring must be conducted whenever drilling activities are being conducted.

Most probable hazards requiring monitoring include volatile organic chemicals or concentrations above the permissible exposure limit (PEL), by using a PID. Any detection by the PID will be noted.

When conducting, air monitoring the following actions should be considered:

- ❑ Be familiar with the proper use and limitations of the air monitoring equipment to be used.
- ❑ Ensure air-monitoring equipment is in working order and has been properly calibrated.
- ❑ Clearly document the results of air monitoring, including:
 - Equipment name / type and calibration data
 - Date, time and site location of air monitoring
 - Indication of what is being measured (LEL, oxygen, or ppm)
 - Results of the air monitoring

- Measurements taken to determine the need for respiratory protection should be taken within the worker's "breathing zone", keeping in mind the worker's closest proximity to the hazard source.

The following levels of PPE will be used if PID/OVA and colorimetric tube concentrations inside the active exclusion zones are measured:

- Less than or equal to background: Level D;
- Greater than background and less than 5 ppm above background: Level C; and
- Greater than 5 ppm: Field activities will be immediately halted, and the location will be vacated until further evaluation.

These action levels in the exclusion zone were selected based on the protection factor (PF) afforded by a half-face APR equipped with combination high efficiency particulate air (HEPA) and organic vapor/acid gas cartridges. The PF for a half-face APR is 10. This means that the respirator can be worn in most cases up to 10 times the Threshold Limit Value (TLV) for the chemical. Since the lowest TLV for most compounds is 1 ppm, a half-face APR could be worn when ambient levels of VOCs are 10 ppm or less [permissible ambient level = PF x TLV = 10 x 1 ppm = 10 ppm]. These action levels are considered to be conservative.

9.0 SITE SECURITY

Appropriate security measures will be established and communicated to site personnel. The objective of these measures is to (1) protect the public from potential exposure to physical/chemical hazards; (2) avoid public interference with personnel and safe work practices; and (3) prevent theft or vandalism of equipment at the site.

10.0 SITE CONTROL

Control of the work site is an important part of maintaining a safe work environment for anyone working on or visiting the site. Supervision and strict control of access to the property is necessary to protect site personnel, visitor and the public.

The primary objective of site control is to minimize the exposure to potentially hazardous substances and/or situations. For the purposes of this H&S plan, site control will be discussed under two circumstances, 1) work not involving direct contact with hazardous substances and 2) work involving direct contact with hazardous substances.

Work not involving direct contact with hazardous substances

Much of the work conducted at the site does not involve direct (or the potential for direct) contact with chemicals at or near hazardous concentrations. Therefore, the establishment of hot/warm/cold work zones may not be necessary. However, the need to control access to the immediate work area and a keen awareness of personnel and visitor safety is essential.

The concept of site control and the establishment of hot/warm/cold work zones are intended for work involving the exposure (or potential exposure) to hazardous chemical concentrations. Under these circumstances, the purpose of work zones is two-fold: 1) minimize the exposure to potentially hazardous substances and 2) minimize the spread of hazardous substances outside the immediate work area through decontamination procedures.

A brief overview of work zones is provided below:

Exclusion Zone (a.k.a. "Hot Zone")

- The area where personnel may be subject to chemical or physical hazards.
- The area where known or suspected contamination exists and may also be where equipment operation and/or environmental sampling will take place.
- The zone is to be clearly identified and should be isolated with cones, barricades, or caution tape.
- The level of personnel protective equipment (PPE) required within the hot zone will vary depending on the work to be performed.

Contamination Reduction Zone (a.k.a "Warm Zone")

- The warm zone is located between the hot and cold zones. It begins at the edge of the hot zone and extends to the cold zone.
- The warm zone should be utilized as a control point or corridor for persons entering or exiting the hot zone.
- Personnel and equipment are decontaminated within the warm zone.

Support Zone (a.k.a. "Cold Zone")

- The cold zone is the area outside the hot zone where administrative and other support functions are located.
- Adverse exposure to contaminants and physical hazards are unlikely in the cold zone.

Due to the expected low levels and types of contaminants at the site, minimum of a hot and cold zone shall be established. It is anticipated that personnel will not need to perform routine decontamination procedures when leaving the hot zone. Should decontamination become necessary to minimize the spread of hazardous contaminants, it will consist of the following:

- Removal of contaminated garments in an "inside out" manner at a designated decontamination station located where personnel enter/exit the hot zone.
- Placement of contaminated garments in designated plastic bags or drums prior to disposal or transfer offsite. Labels in compliance with the hazard communication standard will be affixed to containers of contaminated debris and clothing.

11.0 EMERGENCIES

First Aid & CPR EEC employees and contractors certified in first aid and CPR will be asked to identify themselves at tailgate safety meetings.

Emergency Medical Assistance

An emergency medical assistance network will be established prior to work start-up. The nearest fire department, police, ambulance service, and hospital with an emergency room will be identified. A vehicle shall be available onsite during work activities to transport injured personnel to the identified emergency medical facilities, if necessary. Company vehicles are to be equipped with a fire extinguisher and first aid kit.

See Attachment B for the name, location, and telephone number of emergency response organizations in the vicinity of the project site, and a map to the nearest hospital(s).

11.1 Emergency Procedures

In the event of an accident, injuries, or other emergency, remember to:

- ❑ Stop work and REMAIN CALM.
- ❑ Move all non-injured personnel to a safe location (evacuation plan).
- ❑ Call 911 or notify other emergency facilities, as necessary.
- ❑ Address medical emergencies and apply first aid, as necessary.
 - Move injured or exposed person(s) from immediate area only if it is safe to do so.
 - If serious injury or life-threatening condition exists, call local hospital. Clearly describe the location, injury and conditions to the dispatcher. Designate a person to direct emergency equipment to the injured person.
- ❑ Contain physical hazards. Act only if hazard is minimal and you are trained to deal with the situation. Otherwise evacuate and wait for emergency services to arrive.
- ❑ Notify SSO and initiate accident reporting procedures.
 - See page 2 of this H&S Plan for contact information. In the event the SSO is not available, the order of notification should be 1) Assistant SSO, 2) Project Safety Manager and 3) Project Director.
- ❑ Do not resume work until the SSO has determined is safe to do so.

The nearest telephone will mostly likely be a cellular phone. Call 911 and tell the operator that you need the 911 for your area.

11.2 Evacuation Protocol

Evacuation protocol, routes and meeting point(s) will be established by the SSO, and communicated to personnel during the Tailgate Safety Meeting(s) prior to initiating work. In the event of an evacuation, personnel will meet at a pre-established location and a "head count" will be conducted to see that everyone has left the hazard area.

Primary evacuation meeting point =

Secondary evacuation meeting point =

12.0 ACCIDENT REPORTING

Every injury, accident or near-miss must be reported immediately. All personnel, EEC or contractor, are required to report incidents to their immediate supervisor. The supervisor is responsible for reporting the incident to the SSO. The SSO is responsible to ensure the incident is investigated in accordance with the EEC IIPP and Incident Reporting Policy. The Supervisor's Report of Accident is to be completed and submitted to the SSO and EEC IIPP Coordinator within 24 hours following any accident or injury.

The following information must be collected in order to conduct a proper investigation:

- A description of the event (including date and time) that required notification of offsite personnel (i.e., medical facilities, fire department, police department) and the basis for that decision.
- Date, time, and names of persons/agencies notified, and their response.
- Details regarding personal injury and property damage, if any.
- Resolution of incident and the corrective action involved.

13.0 PERSONNEL TRAINING

This section is applicable only if contamination onsite is encountered. All personnel who will perform field activities shall review this H&S Plan and sign the "Safety Compliance Agreement" before gaining access to the site. The review process may include reading the H&S Plan or participating in a training session that presents the H&S Plan information.

The scope of work to be completed under this H&S Plan is associated with possible soil excavation and disposal. Since work tasks are associated with groundwater remediation operations, a majority of the personnel working at the site do fall under the scope and application of the OSHA Hazardous Waste Operations and Emergency Response (HAZWOPER) Standard [29 CFR 1910.120(a)].

At this time, there is one task that requires HAZWOPER trained individuals:

1. 40-hour training [29 CFR 1910.120(e)(3)(A)] is required for individuals who are engaged in any and all operations that involve excavation, drilling or monitoring.

In the event additional tasks require or result in the requirement of HAZWOPER trained individuals, the SSO will communicate the requirement and verify training before the task is initiated.

Tailgate safety meetings will be conducted periodically, if not at the start of each day. These meetings are intended to review work plans, assign work tasks, discuss potential safety & health hazards, reinforce safety procedures and review emergency response procedures (evacuation meeting points, hospital locations, etc.). Tailgate safety meeting topics and participants will be documented in the supervisor's daily work log and be available for review by the SSO.

As mentioned in Section 8.0, Respiratory Protection, personnel must be medically approved (within one year), fit-tested and trained in the proper use and limitations of the respirator before using an air-purifying gas/vapor respirator. Contractors must provide

proof of the above to the SSO before any air-purifying gas/vapor respirators may be used. The use of air-supplied respiratory protection is not permitted without approval and guidance from the Project Safety Manager.

14.0 H&S PLAN AUTHORIZATION

EEC authorizes the implementation of this H&S Plan and is confident it clearly establishes the responsibilities, requirements, contingencies and procedures for the protection of personnel while performing activities at EEC sites.

Prepared by:

A handwritten signature in black ink, appearing to read 'Sami Malaeb', written in a cursive style.

Sami Malaeb, PE, QSP/ QSD
CE Engineer C60888

ATTACHMENT A
SAFETY COMPLIANCE AGREEMENT

I have reviewed this Site Health and Safety Plan, understand its contents and agree to comply with all safety requirements outlined in the plan.

Signature: _____
Project Director, EEC

Date: _____

Signature: _____
Project Safety Manager, EEC

Date: _____

Signature: _____
Site Safety Officer, EEC

Date: _____

Signature: _____
Assistant Site Safety Officer, EEC

Date: _____

Signature: _____
Print Name: _____

Date: _____
Company: _____

Signature: _____
Print Name: _____

Date: _____
Company: _____

Signature: _____
Print Name: _____

Date: _____
Company: _____

Signature: _____
Print Name: _____

Date: _____
Company: _____

Signature: _____
Print Name: _____

Date: _____
Company: _____

Signature: _____
Print Name: _____

Date: _____
Company: _____

Signature: _____
Print Name: _____

Date: _____
Company: _____

Signature: _____
Print Name: _____

Date: _____
Company: _____

ATTACHMENT A
SAFETY COMPLIANCE AGREEMENT

I have reviewed this Site Health and Safety Plan, understand its contents and agree to comply with all safety requirements outlined in the plan.

Signature: _____
Print Name: _____

Date: _____
Company: _____

Signature: _____
Print Name: _____

Date: _____
Company: _____

Signature: _____
Print Name: _____

Date: _____
Company: _____

Signature: _____
Print Name: _____

Date: _____
Company: _____

Signature: _____
Print Name: _____

Date: _____
Company: _____

Signature: _____
Print Name: _____

Date: _____
Company: _____

Signature: _____
Print Name: _____

Date: _____
Company: _____

Signature: _____
Print Name: _____

Date: _____
Company: _____

Signature: _____
Print Name: _____

Date: _____
Company: _____

Signature: _____
Print Name: _____

Date: _____
Company: _____

Signature: _____
Print Name: _____

Date: _____
Company: _____

Signature: _____
Print Name: _____

Date: _____
Company: _____

ATTACHMENT B

EMERGENCY SERVICES

PHONE NUMBERS, DIRECTIONS, AND LOCAL AREA MAP

EMERGENCY SERVICES

FACILITY / LOCATION

TELEPHONE

Emergency Situation911

HIGHLAND HOSPITAL AND CLINICS

Driving directions to 1411 E 31st St, Oakland, CA 94602

3D2D



2145 35th Ave
Oakland, CA 94601

- 1. Head **southwest** on **35th Ave** toward **Galindo St** 0.3 mi
- 2. Turn right onto **Foothill Blvd** 0.5 mi
- 3. Slight right onto **E 20th St** 0.4 mi
- 4. Turn right onto **23rd Ave** 0.8 mi
- 5. Turn left onto **E 31st St** 0.4 mi
Destination will be on the left



1411 E 31st St
Oakland, CA 94602

Office of Emergency Services

(800) 852-7550

USA Dig Alert of Southern California

(800) 422-4133

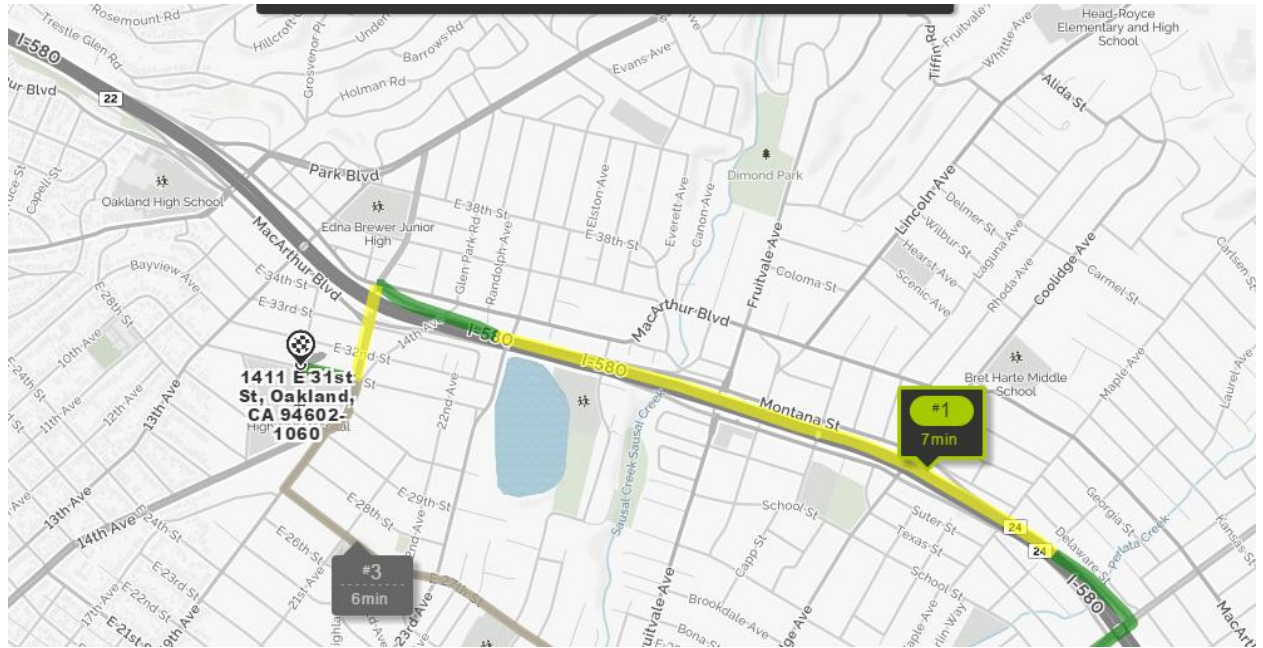

ATTACHMENT C

OCCUPATIONAL HEALTH GUIDELINES
AND TOXICOLOGICAL INFORMATION

TABLE ACTIVITY HAZARD SUMMARY

<u>Type of Hazard</u>	<u>Potential Safety/Health Hazards</u>	<u>Recommended Controls</u>
Physical	Heat Stress	Advise workers to drink 16-ounces of water before beginning fieldwork and continue to drink fluids throughout the work day. Acclimate workers to site work conditions by slowly increasing workloads. Wear loose clothing, appropriate to the weather and field tasks. In hot weather, conduct field activities in the early morning and evening. Allow appropriate rest period (i.e., at least 15 minutes each hour, depending on working and weather conditions). Ensure that adequate shelter is available to protect personnel against heat. See Attachment B.
	Slips, Trips & Falls	Identify and remedy tripping hazards. Follow good housekeeping procedures. Wear proper footwear such as steel-toed leather boots, and walk slowly on slippery surfaces.
	Noise	Wear earplugs or acoustic earmuffs.
	Traffic	Site personnel will wear high-visibility traffic safety vests whenever activities are conducted in areas of heavy traffic. Work vehicles will be arranged to be used as a barrier between site workers and nearby traffic.
Biological	Insects & Snakes	Use insect repellent, where necessary. Wear protective clothing such as leather boots, long pants, and hat and work gloves.
	Vermin	Use caution if working in areas of field crops or other rodent-infested areas. Personal hygiene practices such as frequent hand-washing.

CHEMICAL HEALTH HAZARD INFORMATION

Chemical/ Compound	Cal-OSHA PEL			NIOSH IDLH (ppm)	Target Organs ²	Odor Threshold ³ (ppm)	Routes of Entry ²	Exposure Signs and Symptoms ²
	TWA (ppm)	STEL (ppm)	Ceiling ¹ (ppm)					
Metals								
Lead	Lead	0.05 (mg/M ³)	NE	NE	eyes, gastrointestinal tract, central nervous system, kidneys, blood, gingival tissue	NA	Gastrointestinal tract, CNS, kidneys, blood, gingival tissue	Inhalation, ingestion, skin contact
Polychlorinated biphenyls	0.5 (mg/M ³)	NE	NE	5 (mg/M ³) Ca	Skin, eyes, liver	0.00083	Inhalation, ingestion, skin absorption, skin contact	Irritation of eyes, skin; acne-like dermatitis; potential carcinogen
Petroleum Hydrocarbons								
TPH Gasoline	300	500	NE	NE	CNS, liver, kidneys, respiratory system	0.25	Inhalation, skin absorption, skin contact	Irritation of eyes, skin, mucous membrane; headache, dizziness, lack of coordination; severe exposure anesthesia, coma, respiratory arrest; liver, kidney damage; dermatitis
Benzene	10	NE	NE	500	Eyes, respiratory system, skin, central nervous system, bone marrow	1.5	inhalation, skin absorption, skin and eye contact, ingestion	Irritated eyes, skin, and mucous membranes; dizziness; headache; nausea; staggered gait; anorexia; lassitude (weakness, exhaustion); dermatitis; bone marrow depression
Toluene	100	NE	NE	500	Central nervous system; eyes; liver; kidneys	2.9	inhalation, skin absorption and contact, ingestion	Fatigue, weakness, confusion; euphoria, dizziness, headache; dilated pupils; insomnia; tears, dermatitis; liver, kidney damage

CHEMICAL HEALTH HAZARD INFORMATION

Chemical/ Compound	Cal-OSHA PEL			NIOSH IDLH (ppm)	Target Organs ²	Odor Threshold ³ (ppm)	Routes of Entry ²	Exposure Signs and Symptoms ²
	TWA (ppm)	STEL (ppm)	Ceiling ¹ (ppm)					
Ethylbenzene	100	NE	NE	800	Eyes, upper respiratory system, skin, central nervous system	2.3	inhalation, skin and eye contact, ingestion	irritated eyes, skin, and mucous membranes; headache; dermatitis; sleepiness; narcosis; coma
Xylenes	100	NE	NE	1,000	Central nervous system, eyes; blood; liver, kidneys, Gastro-intestinal tract	1.0	inhalation, skin absorption and contact, ingestion	dizziness, excitement, drowsiness, incoherence, staggering gait; irritated eyes, nose and throat; anorexia; nausea, vomiting, abdominal pain; dermatitis
TPH Diesel	NE	NE	NE	NE	Skin, eyes	NA	Ingestion, skin contact	irritation of eyes, skin, mucous membrane; diarrhea; dermatitis
Motor Oil	5 mg/M ³	NE	NE	NE	Eyes, digestive system, liver, kidneys, CNS	NE	inhalation, ingestion, skin absorption	dermatitis; mildly toxic by ingestion
Volatile Organics (VOCs)								
Tetrachloroethylene (PCE)	PEL = 100 ppm	NE	NE	150	upper respiratory system, eyes, liver, kidneys, CNS	1.0	inhalation, ingestion, skin absorption	abdominal pain, comatose, dizziness, drowsiness, eye irritation, headache, nausea, respiratory system irritation, unconsciousness.
Tetrachloroethylene (PCE)	PEL = 100 ppm	NE	NE	150	upper respiratory system, eyes, liver, kidneys, CNS	1.0	inhalation, ingestion, skin absorption	abdominal pain, comatose, dizziness, drowsiness, eye irritation, headache, nausea, respiratory system irritation, unconsciousness.
1,2-Dichloroethylene (1,2-DCE, including cis- and trans-isomers)	200	NE	NE	1,000	Lungs, kidneys, skin, central nervous system, liver	0.26 (in water) 0.08 (in air)	inhalation, ingestion, skin absorption	irritated skin, central nervous system depression, liver, kidney, and lung damage.

CHEMICAL HEALTH HAZARD INFORMATION

Chemical/ Compound	Cal-OSHA PEL			NIOSH IDLH (ppm)	Target Organs ²	Odor Threshold ³ (ppm)	Routes of Entry ²	Exposure Signs and Symptoms ²
	TWA (ppm)	STEL (ppm)	Ceiling ¹ (ppm)					
Vinyl Chloride (VC)	1.0	NE	NE	NE	liver, central nervous system, blood, respiratory system, lymphatic System	3,000	inhalation, skin and/or eye contact	weakness, abdominal pain, gastrointestinal bleeding, enlarged liver, frostbite, pallor or cyanosis of extremities.

Acronyms:

CNS = central nervous system parts of air
 IDLH = Immediately Dangerous to Life and Limit
 Health concentration cubic meter of air
 NA = not available

NE = not established (not included)
 NIOSH = National Institute of Occupational Safety and Health
 PEL = Permissible Exposure Limit

ppm = parts of substance per million
 STEL = 15-minute Short-Term Exposure
 mg/M³ = milligrams of substance per
 TWA = 8-hour Time-Weighted Average

Notes:

- 1 Ceiling: Instantaneous Exposure Limit
- 2 Reference: NIOSH Pocket Guide to Chemical Hazards, United States Department of Health and Human Services, June 1990.
- 3 Reference: Warning Properties of Industrial Chemicals, Occupational Safety and Health Administration, United States Department of Labor, Grant No. EKF 3D401, and Occupational Health Resource Center, Oregon Lung Association, Portland, Oregon
- 4 Reference: NIOSH International Chemical Safety Cards, October 20, 1999.