



91 NOV - 5 10:43

November 5, 1991

Mr. Paul Smith  
Alameda County Health Care Services Agency  
Hazardous Materials Division  
80 Swan Way, Room 200  
Oakland, California 94621

Re: ACHCSA Letter of 10/7/91 regarding ARCO Station 276 at 10600 MacArthur Boulevard, Oakland, California.

Dear Mr. Smith:

I have received your letter dated October 7, 1991 submitted in response to ARCO's Work Plan for Subsurface Investigation and Remediation and Addendum One to the Work Plan (RESNA, June 27, 1991), Addendum Two to the Work Plan (RESNA, September 23, 1991), and my letter to ACHCSA dated September 6, 1991.

This letter is an attempt to clarify questions raised in your letter concerning existing off site vapor extraction system and the proposed on site vapor extraction system at the subject site. Items you requested clarification on will be addressed in the order listed in your letter.

1. You are requested to provide a map indicating the locations of the existing vapor extraction wells also indicating the locations of the proposed vapor and extraction wells. Please also provide a plumbing schematic indicating the locations of all piping connections into and out of the Remedi-cat treatment system.

Figure 1 is a map showing locations of existing vapor extraction wells and probes. Figure 2 is a map showing locations of proposed vapor extraction wells as depicted in the Addendum One to Work Plan (RESNA, June 27, 1991).

Figure 3 depicts a plan of the offsite vapor treatment system plan and profile.

Figure 4 contains schematic diagrams showing the process diagram, electrical single-line diagram, electric conduit detail, service and joint service trench sections, and plumbing details.

Figure 5 is a set of notes depicting specifications which were used by the contractor during installation of the offsite vapor extraction system.

- 2. Please provide this office with information indicating how the efficacy of the treatment system will be evaluated. Evaluation of the treatment system should include sampling at some specified frequency to evaluate the extraction from each vapor well or series of vapor wells of the same line.**

Appendix A is a copy of the Pacific Environmental Group Inc. (Pacific) report to ARCO dated February 16, 1990. This report details results of vapor extraction performance testing at the site. Results of this testing were used in design of the existing offsite and proposed on site system.

Appendix B is a memorandum from Mr. Dan Landry , Pacific Engineer to Mr. Joel Coffman, RESNA Project Geologist, which details monitoring of the system. As stated in this memorandum, the system is monitored bi-weekly as required in the permit issued by the Bay Area Air Quality Management District. This monitoring includes monthly bag sampling of the influent to the treatment unit and twice a month monitoring of influent and effluent of the treatment unit as well as the influent from the well field with a photoionization detector (PID). In addition, monthly monitoring of individual wells to evaluate efficiency of hydrocarbon removal will commence in November 1991 (Appendix B).

As each vapor well can be individually controlled, each well can be opened up to the system vacuum independent of other wells. The influence/vacuum it induces at other wells can be measured and thus the radius of influence (ROI) can be determined. Similarly, the combined effect of operating all wells/probes at one time will also be measured which allows for calculation of overall ROI. This can be done on a quarterly basis to determine if some wells are clean and should be turned off the system or if some need to be enhanced.

- 3. You are requested to provide this office with some estimation of the anticipated length of time which both the off site and on site system are expected to operate. Please also provide a description of how an effectively site will be determined.**

As part of the proposed on site vapor extraction well installation, laboratory analysis of soil samples collected from the borings drilled for well installation will help delineate the extent of hydrocarbon impacted soils and provide information concerning concentrations of hydrocarbons in the soil. From this information, the approximate volume and specific type of hydrocarbons impacting soil can be calculated. Based on the treatment unit's ability to treat at a flow rate of approximately 250 cubic feet per minute (cfm), the calculated volume of impacted soil, and the estimated concentrations of hydrocarbons in soil in the area, maximum pounds per day (lbs/day) of removed hydrocarbons can be calculated. Much of

this necessary information will not be known until the on site vapor wells are installed. The maximum lbs/day of removed hydrocarbons removed may be limited or adjusted based on permit requirements.

4. You are requested to indicate how the proposed system will prevent further migration of pollutant off site.

Combined with groundwater treatment, further migration will be prevented since hydraulic control will be maintained and faster hydrocarbon removal rates will be achieved by vapor extraction. The proposed groundwater recovery well (Addendum Two to Work Plan, RESNA, September 23, 1991) is scheduled to be installed the week of October 28, 1991 with an aquifer pump and recovery test to be performed in November 1991 for evaluation of aquifer characteristics to facilitate groundwater treatment system design.

5. It is my understanding that the existing system was installed by Pacific Environmental Group, Inc. (PEG) and the proposed system will be installed and operated by RESNA Applied GeoSystems (AG). There is some concern by this office that there will be difficulty in coordinating the efforts of two consultants so that reports which are submitted for Agency review are intelligible. Please specify the measures which will be taken to integrate information from both consultants. The information in question includes: information relating to the details of the proposed treatment system, quarterly progress reporting and the evaluation of both the new and old system during operation and at the completion of the project and also any proposed groundwater treatment proposals and reports.

RESNA and Pacific Environmental Group, Inc. (PEG) have been working in conjunction and in close communication concerning this project for some months. RESNA has been performing quarterly groundwater monitoring and issuing reports accordingly for the on site portion of this project. PEG has been issuing reports concerning the off site system. This set up will continue. The investigations related to on site system installation and groundwater treatment system evaluation and design will be conducted and reported by RESNA. As stated in the memorandum in Appendix B, little difficulty in coordination of this project between the consultants is anticipated.

**The installation of a groundwater recovery well (RW-1) portion of the Work Plan is acceptable. You are required to provide additional information as it becomes available regarding the feasibility of utilizing RW-1 for groundwater treatment in an anticipated future Work Plan proposal for a groundwater treatment system.**

As stated in response to item 4 above, the installation of the recovery well has been scheduled. Following the pump and recovery test, a detailed report of the findings,

ACHCSA Response  
ARCO Station 276, Oakland, California

November 5, 1991

---

interpretations, and conclusions will be issued as stated in the Addendum Two to Work Plan (RESNA, September 23, 1991). This report will be followed by a proposal for a groundwater treatment system to be designed and permitted for installation at the site.

As usual, don't hesitate to call me at (415) 571-2469 if you have any questions.

Sincerely,



Chuck Carmel  
Environmental Engineer

attachments

cc: K.A. Christie, ARCO  
Chris Winsor, ARCO  
Mr. Gil Jensen, Alameda County District Attorney's Office  
Mr. John Meck, ARCO Legal  
Joel Coffman, RESNA  
Dan Landry, Pacific Environmental Group, Inc.

MacARTHUR BOULEVARD

106th STREET

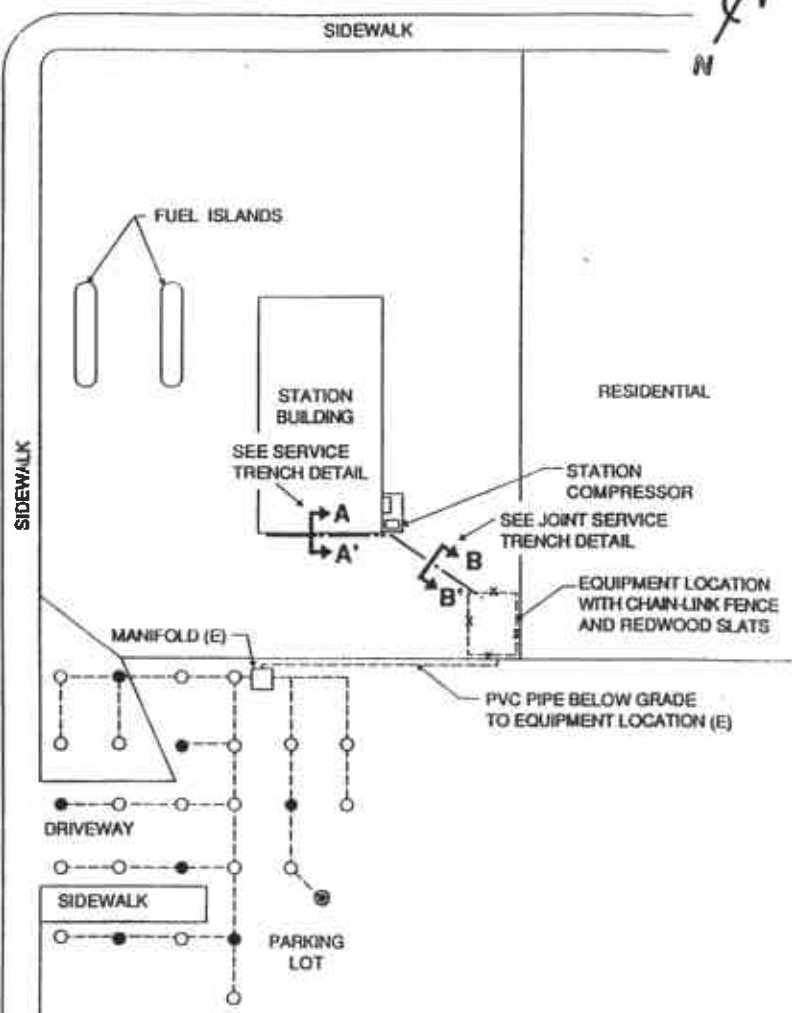

**LEGEND**

- EXISTING MONITORING WELL TO BE USED AS AN EXTRACTION WELL, 22-27' DEPTH
- VACUUM EXTRACTION PROBES, 1/2" SCH 40 STEEL PIPE, 16-21' DEPTH INTERVAL (E)
- VACUUM EXTRACTION PROBES, 1/2" SCH 40 STEEL PIPE, 25-34' DEPTH INTERVAL (E)
- TRENCHING AND PIPING LAYOUT FOR SOIL VENTING SYSTEM
- - - SERVICE TRENCH
- (E) EXISTING



PACIFIC ENVIRONMENTAL GROUP, INC.



ARCO SERVICE STATION #0276  
10600 MacArthur Boulevard at 106th Street  
Oakland, California

SOIL VENT SYSTEM - SITE MAP

FIGURE :  
1  
PROJECT:  
330-40.03

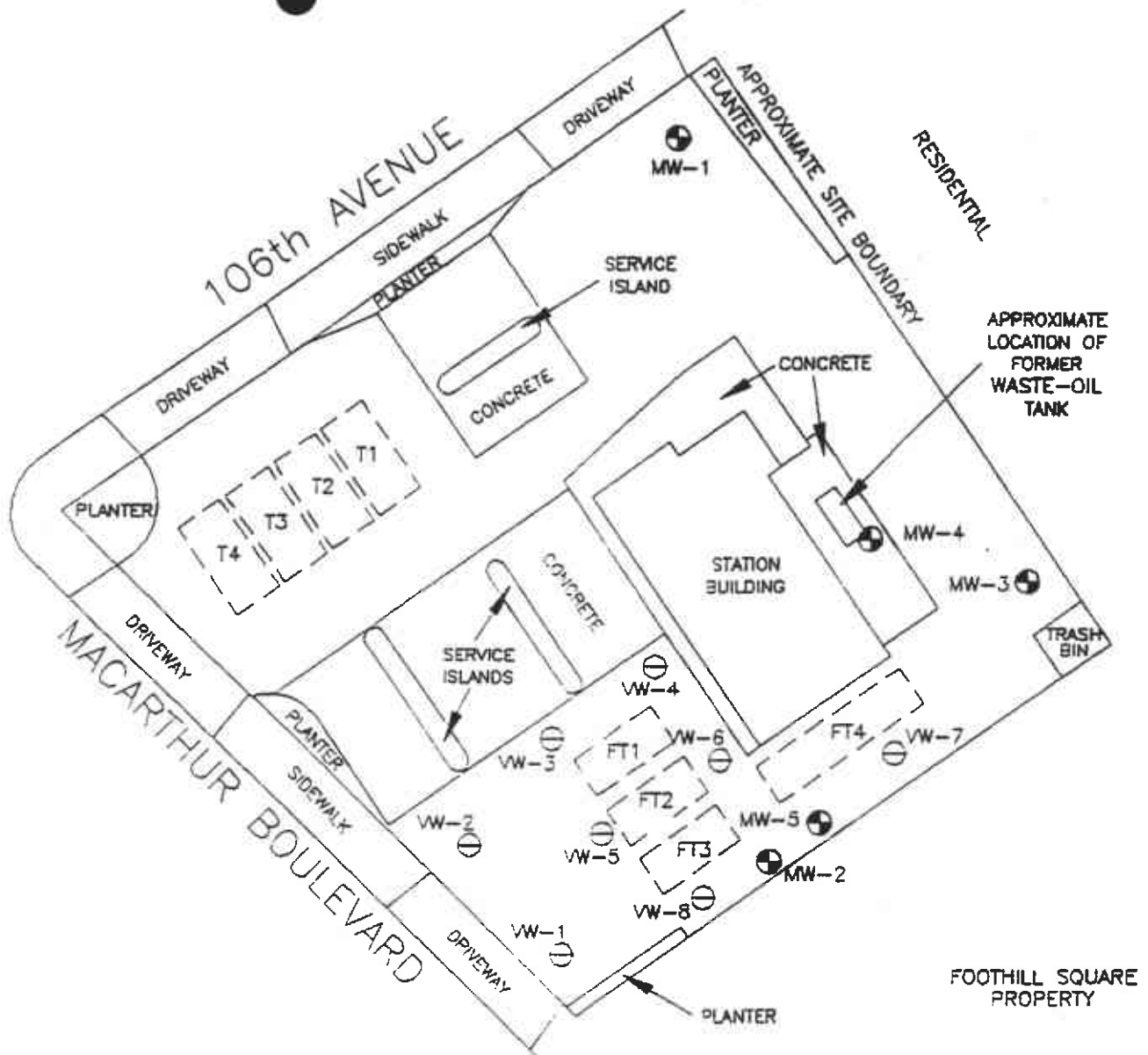

**EXPLANATION**

- VW-8 ⊖ = Proposed vapor extraction well
- MW-5 ⊕ = Approximate location of monitoring well (Applied GeoSystems, 1989)
- T1, T2, T3, T4 = Existing underground storage tanks
- FT1, FT2, FT3, FT4 = Former underground storage tanks

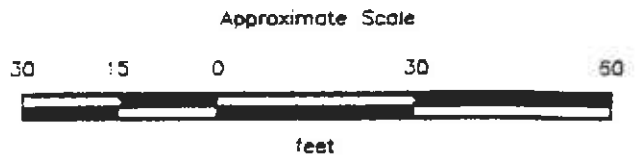

Source: Modified from plan supplied by ARCO and surveyed by Ron Archer, Civil Engineer, Inc.



**PROJECT 60026-4**

**PROPOSED VAPOR  
EXTRACTION WELL LOCATIONS  
ARCO Station 276  
10600 MacArthur Boulevard  
Oakland, California**

**PLATE  
2**

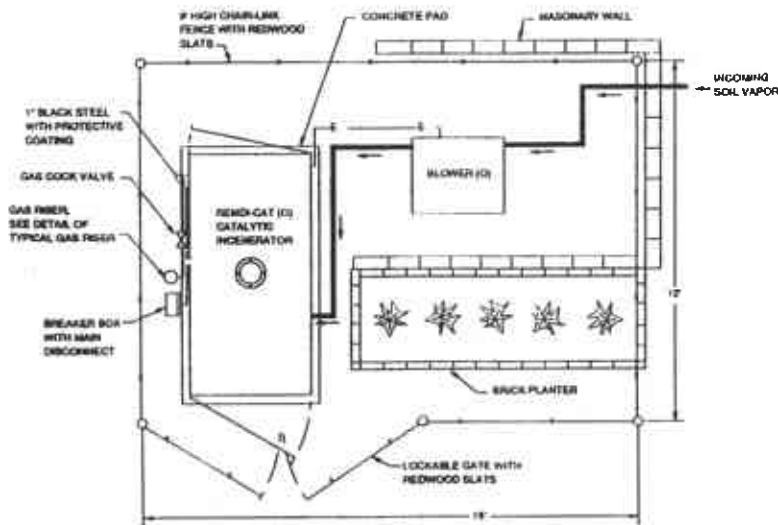

**TREATMENT SYSTEM PLAN**  
NOT TO SCALE

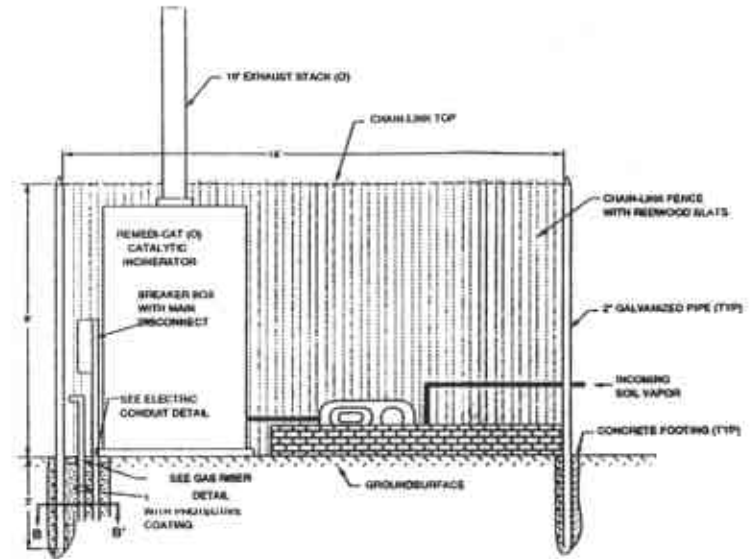

**TREATMENT SYSTEM PROFILE**  
NOT TO SCALE



PACIFIC  
ENVIRONMENTAL  
GROUP, INC.

ARCO SERVICE STATION #0276  
10600 MacArthur Boulevard at 106th Street  
Oakland, California

SOIL VENT SYSTEM - DETAILS

FIGURE:  
**3**  
PROJECT:  
330-40.03

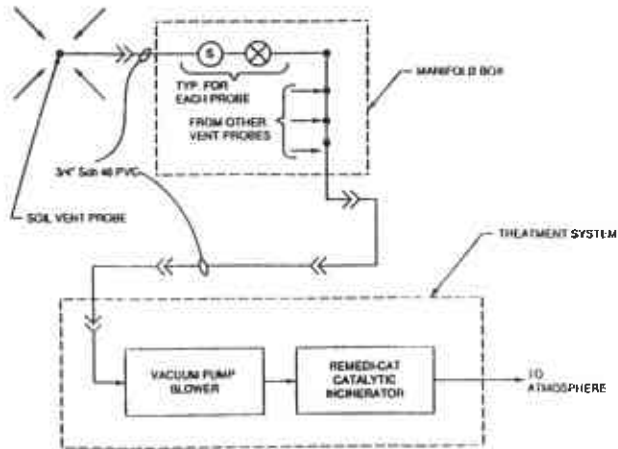

**PROCESS DIAGRAM - SOIL REMEDIATION**  
NO SCALE

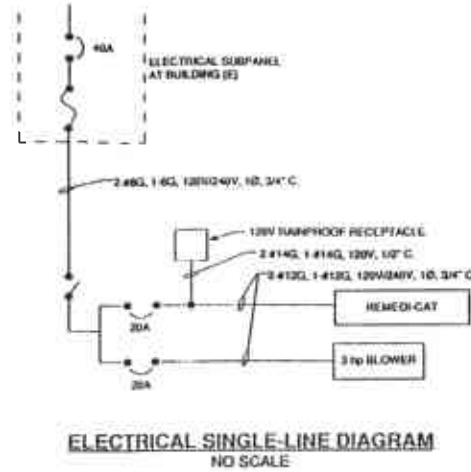

**ELECTRICAL SINGLE-LINE DIAGRAM**  
NO SCALE

LEGEND  
 (S) SAMPLE POINT  
 (X) VALVE

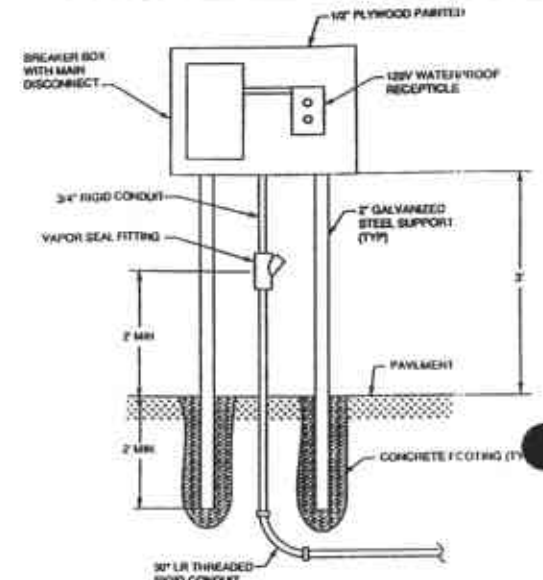

**ELECTRIC CONDUIT DETAIL**  
NO SCALE

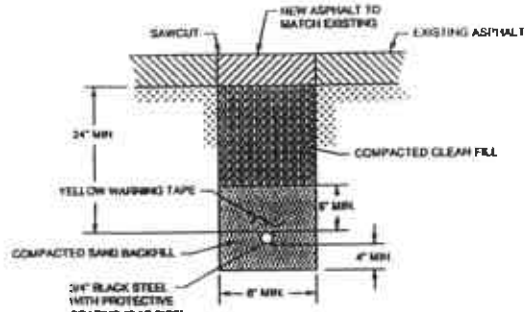

**SERVICE TRENCH**  
**SECTION A-A'**  
NO SCALE

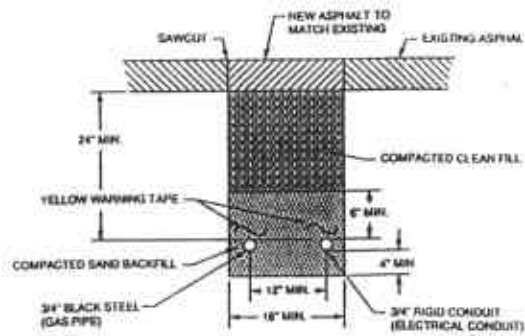

**JOINT SERVICE TRENCH**  
**SECTION B-B'**  
NO SCALE

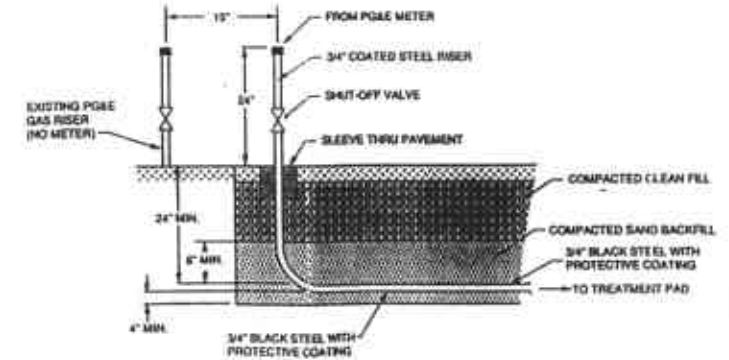

**GAS RISER**  
NO SCALE



PACIFIC ENVIRONMENTAL GROUP INC.

ARCO SERVICE STATION #0276  
10600 MacArthur Boulevard at 106th Street  
Oakland, California

SOIL VENT SYSTEM - DETAILS

FIGURE :  
4  
PROJECT:  
330-40.03



1. All work shall be performed and completed in accordance with all California and City of Oakland building codes.
2. Engineer shall provide building permit. Contractor shall be responsible for obtaining all other permits.
3. Contractor shall be responsible for verifying all field dimensions before beginning work.
4. Contractor shall contact Underground USA to mark all existing utilities at the site and shall be responsible for identifying all conflicting utilities with utility owners before beginning work. Contractor shall repair or replace, at his own cost, utilities that are damaged during construction activities.
5. Contractor shall arrange and schedule all inspections. Contractor shall notify Engineer a minimum of 24 hours prior to all inspections.
6. Existing asphalt surface shall be sawcut along a straight line prior to removal and soil excavation.
7. Service trenches shall be excavated a minimum of 4 inches deeper than the bottom of installed pipes or conduits. All piping shall have a minimum bury of 24 inches.
8. Contractor shall backfill utility trenches as per service trench detail. Backfill shall be clean and placed in accordance with Caltrans Standard Specifications (Caltrans) Section 10-3.025B. Loose thickness of each layer of material before compaction shall not exceed 6 inches. Sand shall have a relative compaction of not less than 95 percent.
9. Asphalt pavement shall be in accordance with Caltrans Section 39 for Type B asphalt concrete. Sawcut edge of existing asphalt pavement shall be cleaned and shall have a coat of liquid asphalt applied prior to construction of new asphalt pavement. Pavement striping shall be restored to existing or better condition.
10. Contractor shall submit record drawings to Owner and Engineer upon 30 days completion of work.
11. 40 amps of existing service on site shall be furnished to treatment location per details. All electric work performed on site shall be performed by a qualified electrician and must conform with local city codes and Pacific Gas and Electric (PG&E) codes.
12. All electrical work within treatment area shall be installed a minimum of 24 inches above grade.
13. All new gas piping shall be pressure tested in accordance with applicable building codes. If any corrections are required, contractor shall make these repairs at his own expense.
14. Gas riser at station building location shall rise 24 inches above ground surface and stem 15 inches to the right of existing PG&E gas riser. Gas riser at treatment location shall have the 24 inch rise requirement only. Both gas risers shall be installed per details.
15. All underground piping and rigid conduit shall have a protective coating applied pending engineers approval.
16. Contractor shall install Fumed Cat, vapor extraction pump (blower), vapor conveyance lines, and miscellaneous appurtenances in accordance with manufacturer's installation requirements.
17. Contractor shall conduct on site work in such a manner as to minimize disruption of the business operation on the site.
18. Contractor shall notify station owner a minimum of 24 hours in advance of any utility shutdowns.
19. All open piping and conduit shall be closed with a removable cap.
20. Contractor shall furnish and install fence and gates with redwood slats in accordance with Caltrans Section 80 for 9 foot high chain link fence. The fence enclosure shall have a chain link top with a 6 inch hole cut out of the top to allow the 10 foot exhaust stack to penetrate the exterior.
21. Any conflicts between these drawing and notes shall be brought to Engineer's attention prior to beginning work.
22. All items required for completion of the job except those noted as owner supplied (O) or existing (E) shall be supplied by the contractor.
23. Contractor shall weatherproof and install Proposition 65 signs on outside of treatment facility fencing. Engineer shall furnish signs.



PACIFIC  
ENVIRONMENTAL  
GROUP, INC.

ARCO SERVICE STATION #0276  
10600 MacArthur Boulevard at 106th Street  
Oakland, California

SOIL VENT SYSTEM - NOTES

FIGURE :  
**5**  
PROJECT:  
330-40.03



PACIFIC  
ENVIRONMENTAL  
GROUP INC.

February 16, 1990  
Project Number 330-40.03

Mr. Kyle Christie  
ARCO Petroleum Products Company  
P.O. Box 5811  
San Mateo, California 94402

Re: ARCO Service Station No. 0276  
10600 MacArthur Boulevard at 106th Street  
Oakland, California

Dear Mr. Christie:

Pacific Environmental Group, Inc. (PACIFIC) is pleased to submit this report concerning ongoing environmental services in an area adjacent to the ARCO station referenced above. At the request of ARCO, PACIFIC has developed a design for the installation and operation of an in-situ soil venting system at this site. The following is a description of the project site and background, the performance testing, and the soil venting system.

#### SITE DESCRIPTION AND BACKGROUND

The project site is a parking lot adjacent to southern boundary of the ARCO station located at 10600 MacArthur Boulevard, Oakland, California (Figure 1). The soil venting system has been designed to remediate an area of approximately 90 feet by 100 feet with soils containing petroleum hydrocarbons. The parking lot is part of a commercial development known as Foothill Square Shopping Center.

The presence of petroleum hydrocarbons in the soil in varying concentrations was previously noted in the Preliminary Report of Environmental Investigation, ARCO Station Number 276, May 12, 1989, prepared by Applied Geosystems, and a soil vapor investigation performed by PACIFIC on June 21 and 22, 1989, and reported to ARCO in PACIFIC's letter report of July 17, 1989.

During the PACIFIC investigation a total of sixteen soil gas probes were installed, both at the ARCO station and in the adjacent parking lot. Probes installed in the parking lot were sampled at two depth intervals: 17 to 19 feet and 22 to 24 feet deep. As previously reported by PACIFIC, total hydrocarbon concentrations in the upper sample elevations ranged from 5 parts per million (ppm) to 31,900 ppm; total petroleum concentrations in the lower sample elevations ranged from 20 ppm to 40,000 ppm.

Remedial efforts at the site are currently focused on off-site soil vapor extraction. On-site remedial activities should be initiated following the ongoing tank replacement project. This should avoid the potential destruction of an on-site soil vapor extraction system during the tank replacement project.

#### PERFORMANCE TESTING

Vapor extraction probes were installed at the site in order to test the feasibility of soil venting as a remedial method, and to provide data for the design of an in-situ soil venting system. Six vapor extraction probes, consisting of one-half inch diameter steel pipe, and an existing three inch diameter monitoring well were used to execute the performance testing.

Three of the probes were driven to depths of 20 feet, with perforations from 15 to 20 feet deep, while the three remaining probes were driven to a depth of thirty feet, with perforations from 24 to 29 feet deep (see Figure 2). The perforated sections allow for the flow of vapors from the soil into the extraction vents.

Results of the performance testing indicated that subsurface soil conditions would support a soil venting system incorporating vapor extraction vents spaced approximately 30 feet on center (see Table 1). The proposed system design actually incorporated a closer vent spacing layout of approximately 15 to 20 feet on center, in an effort to expedite remediation at the request of ARCO.

#### SOIL VENTING SYSTEM

The in-situ soil venting system consists of two major components:

- o Twenty five soil vapor extraction probes (or soil vents), one vadose well, associated piping, and manifold device
- o A mobile extraction and treatment device

The twenty five soil vents, consisting of one-half inch diameter steel pipe, were driven to depths of up to 34 feet with pneumatic equipment (see Figure 3). Seven of the soil vents are perforated from a depth of 16 to 21 feet, while the eighteen remaining soil vents are perforated from 25 to 34 feet. The original design called for the installation of twenty eight soil extraction probes, but subsurface obstructions prevented the installation of three probes. Since the design incorporated a vent spacing more compact than required by subsurface conditions, the elimination of these probes should not impact the effectiveness of the remedial effort.

In addition, an existing three-inch monitoring well is utilized as a vadose well for the remediation of soils containing petroleum hydrocarbons between the depths of approximately 22 and 27 feet. This well is essentially an oversized soil vent which provides a medium for a higher flow rates of vapors from soils in the vicinity of the well.

Both the soil vents and the vadose well have been piped to a below-grade manifold device which will control individual vapor extraction flow rates. The vent piping has been routed across the site in shallow trenches and buried in the trenches at a depth of approximately one foot. The surface of the parking lot in the remediation area was repaired with asphalt paving to match the surrounding surfaces.

A mobile extraction and treatment device shall be used initially to extract and treat soil vapor for petroleum hydrocarbons. The device consists of an extraction pump or blower, and an internal combustion engine powered by propane. This device is capable of extracting soil vapor and oxidizing greater than 98% of the petroleum hydrocarbons. Emissions from the combustion device shall comply with the requirements of air-quality permits issued by the Bay Area Air Quality Management District (BAAQMD). The combustion device has previously been permitted on other sites under the BAAQMD's jurisdiction, and the permit has been transferred to this site.

After hydrocarbon concentrations are reduced to levels which are anticipated to be acceptable for long term ambient venting (LTAV), the mobile extraction and combustion device shall be replaced by an electric vacuum pump and dilution system. The system is tentatively scheduled to begin operation in mid-February 1990, and is projected to continue operating for approximately one year.

A report on the system installation and initial start-up monitoring data will be forthcoming. PACIFIC appreciates this opportunity to be of service. Please call if you have any questions concerning the contents of this report.

Sincerely,

PACIFIC ENVIRONMENTAL GROUP, INC.

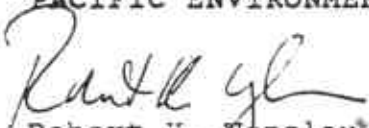
  
Robert K. Wenzlau, P.E.  
Senior Engineer



enclosures

TABLE 1  
 INFLUENCE STUDY PERFORMANCE DATA

Probe/Well ID	Influence Vac ("H2O)	Extraction Note cfm	Perforated Depth	Capture Radius	Extraction Vacuum ("Hg)	Probe/Well Diameter
Extrc >MW3	--	14.0	22.0-27.0'	--	8.0	3.0"
A	.1	--	15.0-20.0'	5.0'	--	1/2"
B	.02	--	15.0-20.0'	15.0'	--	1/2"
C	0	--	15.0-20.0'	20.0'	--	1/2"
F	.17	--	24.0-29.0'	20.0'	--	1/2"
Extrc >MW3	--	12.0	22.0-27.0'	--	8.0	3.0"
A	.1	--	15.0-20.0'	5.0'	--	1/2"
B	.05	--	15.0-20.0'	15.0	--	1/2"
C	0	--	15.0-20.0'	20.0'	--	1/2"
F	>.25	--	24.0-29.0'	20.0'	--	1/2"
Extrc >MW3	--	12.0	22.0-27.0'	--	8.0	3.0"
A	.1	--	15.0-20.0'	5.0'	--	1/2"
B	.04	--	15.0-20.0'	15.0'	--	1/2"
C	0	--	15.0-20.0'	20.0'	--	1/2"
F	>.25	--	24.0-29.0	20.0'	--	1/2"
Extrc >MW3	--	12.0	22.0-27.0'	--	8.0	3.0"
A	.1	--	15.0-20.0'	5.0'	--	1/2"
B	.04	--	15.0-20.0'	15.0'	--	1/2"
C	0	--	15.0-20.0'	20.0'	--	1/2"
F	>.25	--	24.0-29.0'	20.0'	--	1/2"
Extrc >A MW3	--	2.0	15.0-20.0'	--	15.0	1/2"
B	.015	--	22.0-27.0'	5.0'	--	3.0"
C	.01	--	15.0-20.0'	10.0'	--	1/2"
F	0	--	15.0-20.0'	15.0'	--	1/2"
	0	--	25.0-29.0'	15.0'	--	1/2"

TABLE 1  
 (continued)

INFLUENCE STUDY PERFORMANCE DATA

Probe/Well ID	Influence Vac ("H2O)	Extraction Note cfm	Perforated Depth	Capture Radius	Extraction Vacuum ("Hg)	Probe/Well Diameter
Extrc >A MW3 B C F	--	2.0	15.0-20.0'	--	15.0	1/2"
	0	--	22.0-27.0'	5.0'	--	3.0"
	.01	--	15.0-20.0'	10.0'	--	1/2"
	0	--	15.0-20.0'	15.0'	--	1/2"
	0	--	24.0-29.0'	15.0'	--	1/2"
Extrc >A MW3 B C F	--	2.0	15.0-20.0'	--	15.0	1/2"
	0	--	22.0-27.0'	5.0'	--	3.0"
	.01	--	15.0-20.0'	10.0'	--	1/2"
	0	--	15.0-20.0'	15.0'	--	1/2"
	0	--	24.0-29.0'	15.0'	--	1/2"
Extrc >A MW3 B C F	--	2.0	15.0-20.0'	--	15.0	1/2"
	0	--	22.0-27.0'	5.0'	--	3.0"
	.03	--	15.0-20.0'	10.0'	--	1/2"
	0	--	15.0-20.0'	15.0'	--	1/2"
	0	--	24.0-29.0'	15.0'	--	1/2"
Extrc >D MW3 B C F	--	2.5	24.0-29.0'	--	15.0	3.0"
	0	--	22.0-27.0'	5.0'	--	1/2"
	0	--	15.0-20.0'	10.0'	--	1/2"
	0	--	15.0-20.0'	15.0'	--	1/2"
	0	--	24.0-29.0'	15.0'	--	1/2"
Extrc D MW3 B C F	--	2.5	25.0-29.0'	--	15.0'	1/2"
	0	--	22.0-27.0'	5.0'	--	3.0"
	0	--	15.0-20.0'	10.0'	--	1/2"
	0	--	15.0-20.0'	15.0'	--	1/2"
	0	--	24.0-29.0'	15.0'	--	1/2"

TABLE 1  
 (continued)

INFLUENCE STUDY PERFORMANCE DATA

Probe/Well ID	Influence Vac ("H <sub>2</sub> O)	Extraction Note cfm	Perforated Depth	Capture Radius	Extraction Vacuum ("Hg)	Probe/Well Diameter
Extrc >D MW3	--	2.5	24.0-29.0'	--	15.0	1/2"
	0	--	22.0-27.0'	5.0'	--	3.0"
	.01	--	15.0-20.0'	10.0'	--	1/2"
	0	--	15.0-20.0'	15.0'	--	1/2"
	0	--	24.0-29.0'	15.0'	--	1/2"
Extrc >D MW3	--	2.5	24.0-29.0'	--	15.0	1/2"
	0	--	22.0-27.0'	5.0'	--	3.0"
	.01	--	15.0-20.0'	10.0'	--	1/2"
	0	--	15.0-20.0'	15.0'	--	1/2"
	.005	--	24.0-29.0'	15.0'	--	1/2"
Extrc >D MW3	--	2.5	24.0-29.0'	--	15.0	1/2"
	0	--	22.0-27.0'	5.0'	--	3.0"
	0.2	--	15.0-20.0'	10.0'	--	1/2"
	0	--	15.0-20.0'	15.0'	--	1/2"
	0	--	24.0-29.0'	15.0'	--	1/2"
Extrc >MW3	--	14.0	22.0-27.0'	--	11.0	3.0"
	.02	--	15.0-20.0'	15.0'	--	1/2"
	0	--	24.0-29.0'	5.0'	--	1/2"
	.01	--	24.0-29.0'	15.0'	--	1/2"
	0	--	24.0-29.0'	20.0'	--	1/2"
Extrc >MW3	--	13.0	22.0-27.0'	--	12.0	3.0"
	.03	--	15.0-20.0'	15.0'	--	1/2"
	0	--	24.0-29.0'	5.0'	--	1/2"
	.01	--	24.0-29.0'	15.0'	--	1/2"
	0	--	24.0-29.0'	20.0'	--	1/2"

TABLE 1  
 (continued)

INFLUENCE STUDY PERFORMANCE DATA

Probe/Well ID	Influence Vac("H2O)	Extraction Note cfm	Perforated Depth	Capture Radius	Extraction Vacuum ("Hg)	Probe/Well Diameter
Extrc >MW3	--	15.0	22.0-27.0'	--	12.0	3.0"
B	.04	--	15.0-20.0'	15.0'	--	1/2"
D	0	--	24.0-29.0'	5.0'	--	1/2"
E	.01	--	24.0-29.0'	15.0'	--	1/2"
F	0	--	24.0-29.0'	20.0'	--	1/2"
Extrc >MW3	--	15.0	22.0-27.0'	--	12.0	3.0"
B	.04	--	15.0-20.0'	15.0'	--	1/2"
D	.005	--	24.0-29.0'	5.0'	--	1/2"
E	.01	--	24.0-29.0'	15.0'	--	1/2"
F	0	--	24.0-29.0'	20.0'	--	1/2"
Extrc >E	--	20.0	24.0-29.0'	--	16.0	1/2"
A	.005	--	15.0-20.0'	10.0'	--	1/2"
D	0	--	24.0-29.0'	10.0'	--	1/2"
B	0	--	15.0-20.0'	3.0'	--	1/2"
F	.02	--	24.0-29.0'	5.0'	--	1/2"
Extrc >E	--	12.0	24.0-29.0'	--	16.0	1/2"
A	.01	--	15.0-20.0'	10.0'	--	1/2"
D	0	--	24.0-29.0'	10.0'	--	1/2"
B	.005	--	15.0-29.0'	3.0'	--	1/2"
F	.04	--	24.0-29.0'	5.0'	--	1/2"
Extrc >E	--	14.0	24.0-29.0'	--	16.0	1/2"
A	.005	--	15.0-20.0'	10.0'	--	1/2"
D	0	--	24.0-29.0'	10.0'	--	1/2"
B	.005	--	15.0-20.0'	3.0'	--	1/2"
F	.055	--	24.0-29.0'	5.0'	--	1/2"



TABLE 1  
 (continued)

INFLUENCE STUDY PERFORMANCE DATA

Probe/Well ID	Influence Vac ("Hg)	Extraction Note cfm	Perforated Depth	Capture Radius	Extraction Vacuum ("Hg)	Probe/Well Diameter
Extrc >E	--	12.0	24.0-29.0'	--	16.0	1/2"
A	.01	--	15.0-20.0'	10.0'	--	1/2"
D	0	--	24.0-29.0'	10.0'	--	1/2"
B	.005	--	15.0-20.0'	3.0'	--	1/2"
F	.08	--	24.0-29.0'	5.0'	--	1/2"
Extrc >E	--	10.0	22.0-27.0'	--	16.0	1/2"
A	.015	--	15.0-20.0'	10.0'	--	1/2"
D	0	--	24.0-29.0'	10.0'	--	1/2"
B	0	--	15.0-20.0'	3.0'	--	1/2"
F	.1	--	24.0-29.0'	5.0'	--	1/2"
Extrc >C	--	2.5	15.0-29.0.0'	--	16.0	1/2"
A	.01	--	15.0-20.0'	20.0'	--	1/2"
D	0	--	24.0-29.0'	20.0'	--	1/2"
B	0	--	15.0-20.0'	5.0'	--	1/2"
F	0	--	24.0-29.0'	3.0'	--	1/2"
Extrc >C	--	3.0	15.0-20.0'	--	17.0	1/2"
A	.03	--	15.0-20.0'	20.0'	--	1/2"
D	0	--	24.0-29.0'	20.0'	--	1/2"
B	.005	--	15.0-20.0'	5.0'	--	1/2"
F	0	--	24.0-29.0'	3.0'	--	1/2"
Extrc >C	--	3.0	15.0-20.0'	--	17.0	1/2"
A	.02	--	15.0-20.0'	20.0'	--	1/2"
D	0	--	24.0-29.0'	20.0'	--	1/2"
B	.005	--	15.0-2.0'	5.0'	--	1/2"
F	0	--	24.0-29.0'	3.0'	--	1/2"

TABLE 1  
 (continued)

INFLUENCE STUDY PERFORMANCE DATA

Probe/Well ID	Influence Vac ("H <sub>2</sub> O)	Extraction Note cfm	Perforated Depth	Capture Radius	Extraction Vacuum ("Hg)	Probe/Well Diameter
Extrc >C	--	3.0	15.0-20.0'	--	17	1/2"
A	.02	--	15.0-20.0'	20.0'	--	1/2"
D	0	--	24.0-29.0'	20.0'	--	1/2"
B	.005	--	15.0-20.0'	5.0'	--	1/2"
F	0	--	24.0-29.0'	3.0'	--	1/2"
Extrc >C	--	3.2	15.0-20.0'	--	3.2	1/2"
A	.02	--	15.0-20.0'	20.0'	--	1/2"
D	0	--	24.0-29.0'	20.0'	--	1/2"
B	.01	--	15.0-20.0'	5.0'	--	1/2"
F	0	--	24.0-29.0'	3.0'	--	1/2"
Extrc >F	--	3.0	24.0-29.0'	--	17.0	1/2"
A	.02	--	15.0-20.0'	20.0'	--	1/2"
D	0	--	24.0-29.0'	20.0'	--	1/2"
B	0	--	15.0-20.0'	5.0'	--	1/2"
E	.01	--	24.0-29.0'	5.0'	--	1/2"
Extrc >F	--	3.0	24.0-29.0'	--	17.0	1/2"
A	.01	--	15.0-20.0'	20.0'	--	1/2"
D	0	--	24.0-29.0'	20.0'	--	1/2"
B	.005	--	15.0-29.0'	5.0'	--	1/2"
E	.01	--	24.0-29.0'	5.0'	--	1/2"
Extrc >F	--	3.0	24.0-29.0'	--	17.0	1/2"
A	.02	--	15.0-20.0'	20.0'	--	1/2"
D	0	--	24.0-29.0'	20.0'	--	1/2"
B	0	--	15.0-20.0'	5.0'	--	1/2"
E	.02	--	24.0-29.0'	5.0'	--	1/2"

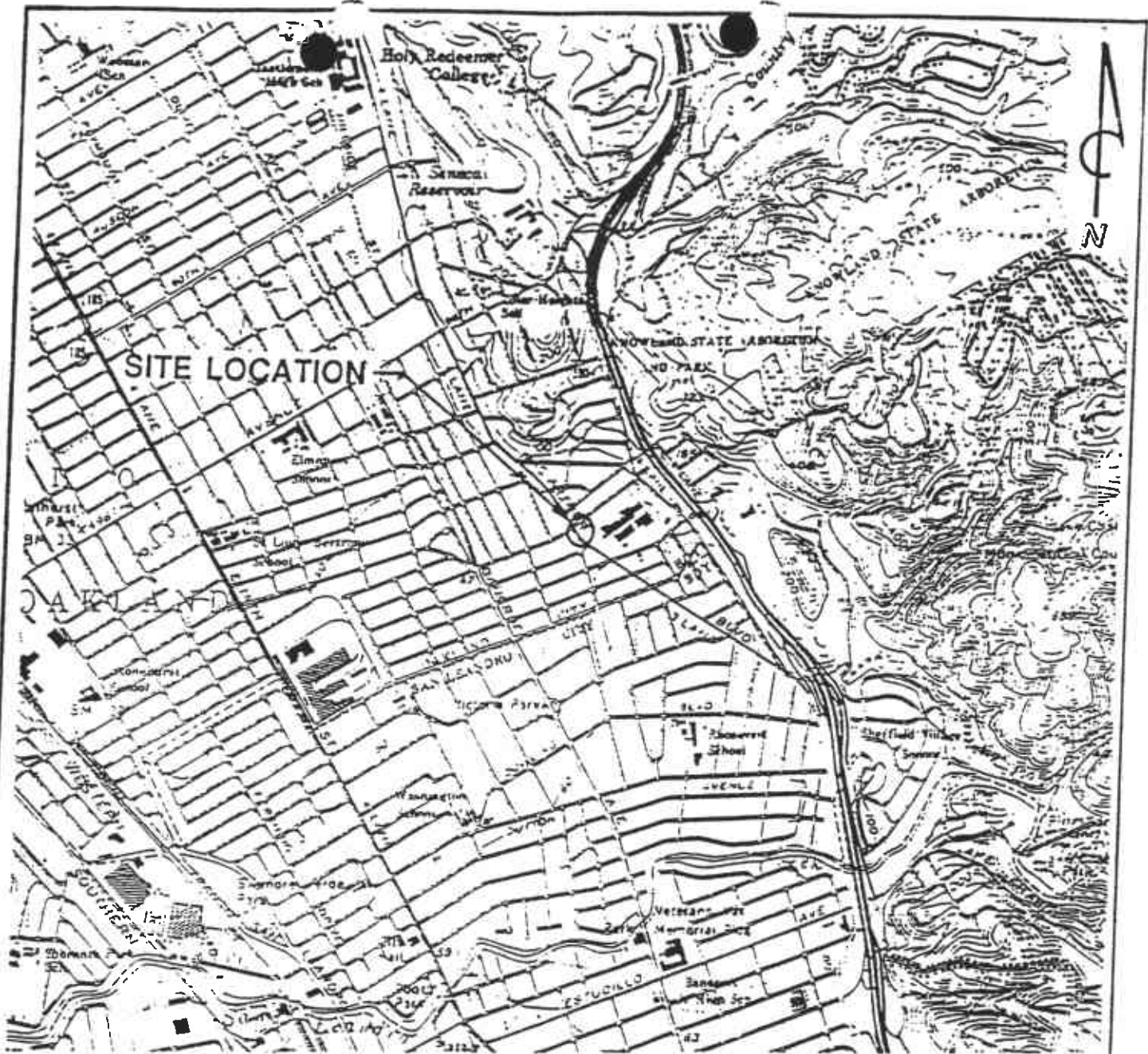

QUADRANGLE  
LOCATION

**REFERENCE:**

USGS 7.5 MIN. TOPOGRAPHIC MAP  
TITLED: OAKLAND EAST, CALIFORNIA  
DATED: 1959 REVISED: 1980  
TITLED: SAN LEANDRO, CALIFORNIA  
DATED: 1959 REVISED: 1980

SCALE



PACIFIC  
ENVIRONMENTAL  
GROUP INC.

ARCO STATION #0276  
10600 MacArthur Boulevard  
Oakland, California

SITE LOCATION MAP

FIGURE:

1

PROJECT:

330-40.03

106th STREET

SIDEWALK



FUEL ISLANDS

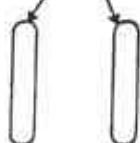

STATION BUILDING

RESIDENTIAL

MACARTHUR BOULEVARD

SIDEWALK

TREE

PLANTER

5' ABOVE STATION LOT GRADE

**LEGEND**

DRIVEWAY

- C ⊕ ⊗ F
- B ⊕ ⊗ E
- A ⊕ ⊗ D

MW-3 ⊙ MONITORING WELL LOCATION AND DESIGNATION

SIDEWALK

A ⊙ PROBE, 3/4" STEEL SCH 40 PIPE 15-20' DEPTH INTERVAL

MW-3 ⊙

TREE PLANTER

D ⊕ PROBE, 3/4" STEEL SCH 40 PIPE 24-29' DEPTH INTERVAL

PLANTER

PARKING LOT

SCALE

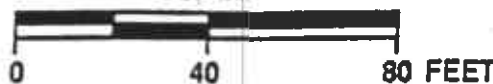

PACIFIC ENVIRONMENTAL GROUP, INC.

ARCO SERVICE STATION #0276  
10600 MacArthur Boulevard  
Oakland, California

PERFORMANCE TESTING LAYOUT

FIGURE:  
2  
PROJECT:  
330-40.03

106th STREET

SIDEWALK



MACARTHUR BOULEVARD

SIDEWALK

FUEL ISLANDS

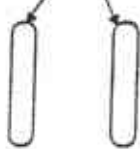

STATION BUILDING



RESIDENTIAL

MANIFOLD

EQUIPMENT LOCATION WITH CHAIN LINK FENCE AND SLATS

PVC PIPE BELOW GRADE TO EQUIPMENT LOCATION

DRIVEWAY

SIDEWALK

PARKING LOT

PLANTER

**LEGEND**

- ⊙ EXISTING MONITORING WELL TO BE USED AS AN EXTRACTION WELL, 22-27' DEPTH
- VACUUM EXTRACTION PROBES, 1/2" SCH 40 STEEL PIPE, 16-21' DEPTH INTERVAL
- VACUUM EXTRACTION PROBES, 1/2" SCH 40 STEEL PIPE, 25-34' DEPTH INTERVAL
- ∅ VACUUM EXTRACTION PROBES ELIMINATED DUE TO OBSTRUCTIONS

----- TRENCHING AND PIPING LAYOUT

SCALE



PACIFIC ENVIRONMENTAL GROUP, INC.

ARCO SERVICE STATION #0276  
10600 MacArthur Boulevard  
Oakland, California

SOIL VENT SYSTEM

FIGURE:  
3  
PROJECT:  
330-40.03

October 23, 1991  
Project

## MEMORANDUM

To: Joel Coffman  
From: Dan Landry  
Subject: Operation and Maintenance

The treatment system is monitored every two weeks per the Bay Area Air Quality Management District's air permit. This monitoring includes monthly bag sampling of the influent to the treatment unit and twice a month monitoring of influent and effluent of the treatment unit as well as the influent from the well field with an FID or PID. The information from the samples is used to evaluate the total pounds of hydrocarbons and benzene removed from the soil and monitor changes in the well field production. Beginning in November monthly monitoring will include FID/PID evaluation of the individual wells. Pacific Environmental Group, Inc. foresees little difficulty in coordinating monitoring of the treatment system with RESNA.