

RECEIVED

By Alameda County Environmental Health 8:32 am, Jun 22, 2016

May 6, 2016

Alameda County Department of
Environmental Health
1131 Harbor Bay Parkway, 2nd Floor
Alameda, CA 94502

Attention: Mark Detterman

Subject: Vapor Mitigation System Design and CQAP
3800 San Pablo Avenue, Emeryville, California
ACDEH Fuel Leak Case: RO00002520; Global ID: T06019788682

Ladies and Gentlemen:

Attached please find a copy of the *Report of Vapor Mitigation System Design and CQAP* prepared by Gribi Associates and Carlin Environmental Consulting. I declare, under penalty of perjury, that the information and/or recommendations contained in the attached document or report is true and correct to the best of my knowledge.

Very truly yours,

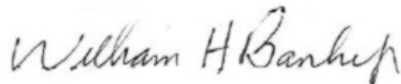

William H. Banker, Jr.
San Pablo Avenue Venture
c/o Banker, Marks & Kirk
1720 Broadway, Suite 202
Oakland, CA 94612



May 6, 2016

Alameda County Department of
Environmental Health
1131 Harbor Bay Parkway, 2nd Floor
Alameda, CA 94502

Attention: Mark Detterman

Subject: Vapor Mitigation System Design and CQAP
3800 San Pablo Avenue, Emeryville, California
ACDEH Fuel Leak Case: RO00002520; Global ID: T06019788682

Ladies and Gentlemen:

In accordance with the December 17, 2015 letter from Alameda County Department of Environmental Health (ACDEH), the following drawings prepared by Carlin Environmental Consulting provide vapor mitigation system design and installation elements for the property located at 3800 San Pablo Avenue in Emeryville, California. The drawings include: (1) A description of the vapor mitigation system (VMS); (2) A description of VMS installation procedures; (3) A construction quality assurance plan (CQAP); (4) An operation and maintenance plan (OMP); and (5) Detailed VMS component drawings. The goal of the VMS will be to provide a long-term measure of safety relative to potential indoor vapor intrusion of subsurface gasoline and methane vapors that resulted from the operation of a gasoline underground storage tank (UST) in the West MacArthur Boulevard sidewalk in the past.

We appreciate this opportunity to provide this letter for your review. Please contact us if there are questions or if additional information is required.

Very truly yours,

A handwritten signature in black ink, appearing to read 'James E. Gribi', written over a light gray circular stamp.

James E. Gribi
Professional Geologist
California No. 5843



JEG:ct
Enclosure

C Mr. Bill Banker, Jr., San Pablo Avenue Venture
Mr. Tom Graf, GrafCon

THE INTERSECTION COMMERCIAL SHELL

3800 SAN PABLO AVENUE
EMERYVILLE, CALIFORNIA

Site Layout:

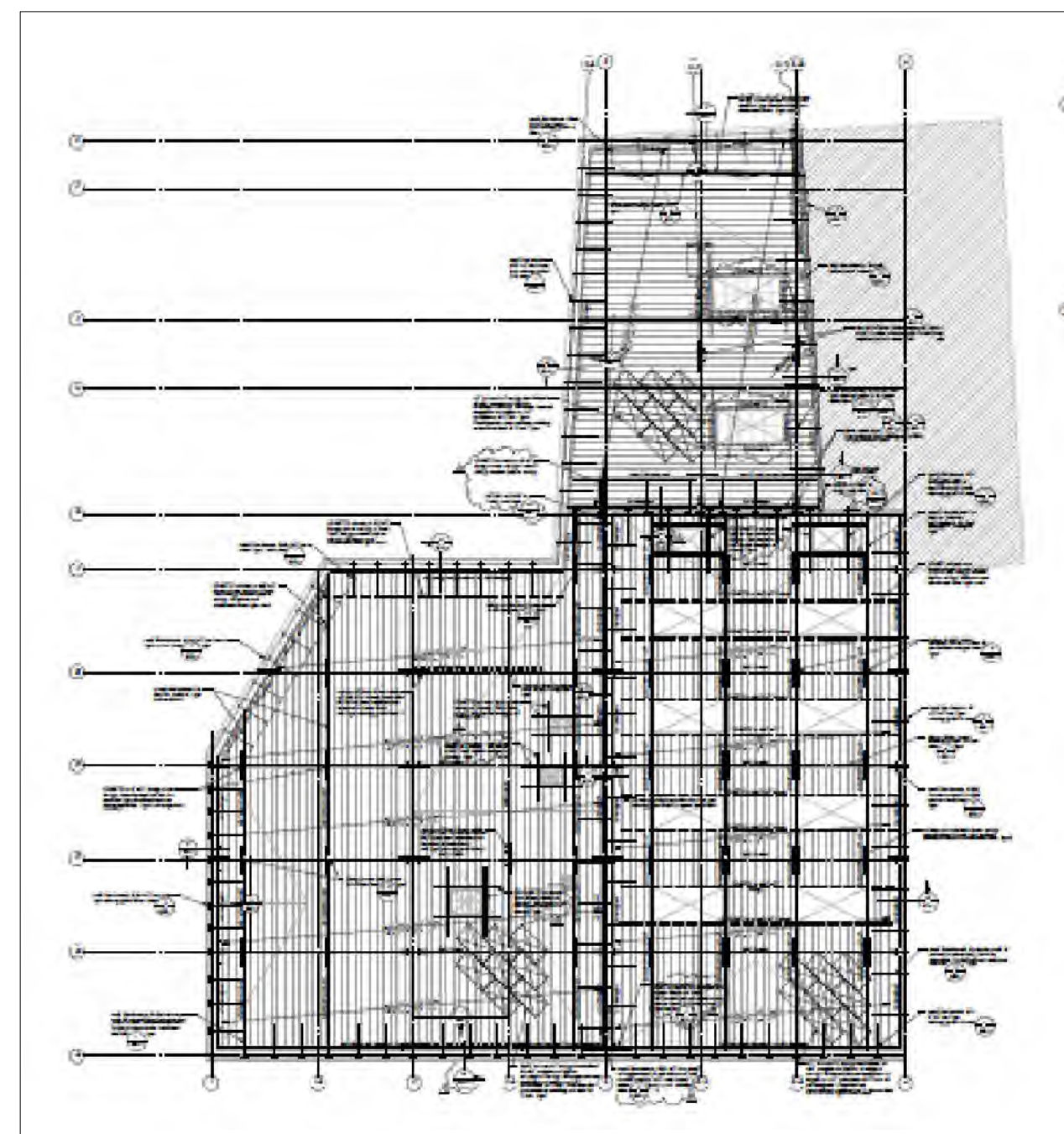

SHEET TITLES	
SHT. 1	COVER SHEET
SHT. 2	SITE LAYOUT
SHT. 3	PIPE DETAILS

CARLIN ENVIRONMENTAL CONSULTING NOTES:

2522 Chambers Road # 100, Tustin, California 92780 Phone: 714-508-1111

To: Holiday Development / 3800 San Pablo LLC

Subject: Summary of Proposed Methane Mitigation System for 3800 San Pablo Avenue, Emeryville, California.

Introduction

Assessment of methane soil vapors in soil gas at the Site is currently being conducted under the oversight of the State Water Resources Control Board (SWRCB) and the Alameda County Environmental Health department (ACEH). The presence of methane in soil, in the form of soil vapor, creates a potential risk of vapor intrusion of methane-affected soil vapor into the existing buildings at the Site.

As reported in a letter on December 17th, 2015, the ACEH staff has determined that the eastern portion of the Site appears to meet the closure criteria specified in the Low Threat Closure Policy. ACEH has determined that the western portion of the site, which is predominately overlain with the existing building, fails the Nuisance General Criteria due to the presence of potentially explosive concentrations of methane in the subsurface. These methane concentrations, as delineated by soil gas tests conducted by Gribi Associates, the consultants for the Site owners, have highlighted the southwestern area of the building to be the area principally associated with elevated methane concentrations, adjacent to a former heating oil underground storage tank (UST). Gribi Associates have conducted numerous testing of soil, soil gas, and groundwater throughout the Site that further support the presence of methane to be concentrated in the southwest corner of the Site.

ACEH has requested that a Vapor Mitigation System (VMS) be designed and implemented into the western portion of the Site to minimize the risk to occupants of accumulating methane gas concentrations. In addition to the VMS design, ACEH has requested a VMS Basis of Design report, including system construction plans and specifications, Construction Quality Assurance Plan (CQAP) for installation of the system, and an Operations and Maintenance Plan.

Carlin Environmental Consulting, Inc. has been contracted by Holiday Development, the project owner to prepare the Methane Gas Mitigation Measures design, the CQAP, and the Operations and Maintenance Plan to meet the requirements of the ACEH. These drawings represent CEC's recommendations to address the issue. It is our opinion that if the methane mitigations measures depicted on these drawings are implemented, future site inhabitants will be properly protected.

VMS Design

The proposed methane gas mitigation system will consist of a single perforated vent pipe placed within an excavated trench in the existing building foundation and a membrane barrier system above the venting pipe. The venting system will provide a route for methane gas in the southwest area of the Site to vent directly to the atmosphere and reduce the possibility of methane concentrations building up in the aboveground structures. The engineered barrier system will provide a positive barrier to the migration of methane gas into the existing buildings. Passive venting rely on thermal and wind effects to draw methane gas from beneath the building to be vented to the atmosphere.

The purpose of the Methane Gas Mitigation System is to redirect and prohibit the intrusion of methane gas from the subsurface into the existing building at the Site at concentrations that may pose a risk to human health. To provide a redundant system, two elements will be included:

- Sub-slab venting system - The venting system includes a permeable layer constructed beneath the building using a gravel bed and will include soil vapor collection pipe(s) that will route soil vapor to the vent riser(s). Vent riser(s) will convey the collected soil vapor to the roof of the new building to allow venting to the atmosphere. A low permeability wrap will be used to encase the contents of the trench (gravel backfill and 4" perforated pipe) to preclude the mixture of native soil into the gravel layer.
- Vapor barrier system - The barrier system includes a very low permeability layer constructed between the venting system and the building floor slabs and foundations and sealing around each penetration. In this case CEC recommends that a double thickness of polyethylene sheeting be placed at the top of the trench just beneath the concrete floor. The intention of the design is to cause any methane pressure accumulation to be collected in the trench and perforated vent piping where it will flow due to pressure differentiation out the vent riser. The sheeting is placed as a resistant, relatively impermeable layer that will cause the gas to migrate into the venting system instead of through the floor of the building.

The design of the vapor mitigation system plans have been prepared by a State of California licensed Professional Engineer with the appropriate experience and knowledge in the design of vapor mitigation systems. The sub-slab venting system will be designed to be passive.

Construction Quality Assurance Plan

The CQAP program will consist of utilizing a contractor that is experienced with materials and methods described on the design plans. Ideally they should have installed similar systems in the past. Inspection of the installation of the designed system should be by qualified personnel whom are familiar with the design plans and construction of similar systems. This includes verifying that the appropriate material are utilized and that they are properly placed and in accordance with the approved design mitigation plans. It is proposed that staff members of CEC inspect the components of the system as they are installed and certifying, in writing, that the measures were installed in strict accordance with the approved drawings. CEC inspectors have been through the City of Los Angeles Deputy Inspector Certification Program and have experience inspecting similar installations. A letter will be prepared at the completion indicating that all components were per the plans and installed per recommendations.

Operations and Maintenance Plan

The Operation and Maintenance Plan (OMP) will consist of maintenance and monitoring of the components of the VMS that was installed. Properly maintaining the sub-slab components of the system does not require any activities other than preventing future cutting and/or penetrations beneath the slab. CEC recommends that this component should be identified and be acknowledged as condition of the certificate of occupancy of the building. The vent pipe will be vented through the roof and exposed to the atmosphere. Therefore, the vents should be annually inspected to be free of any foreign objects that might restrict the flow of methane from the subsurface into the atmosphere. These annual inspections should be properly documented by building occupants, owners, property managers.

Installation

The installation of the VMS system is detailed on the design drawings and briefly summarized below for convenience.

Step-by-Step Instructions:

- Saw cut out a section of the existing slab, approximately 2 feet wide for approximately 70 feet in length from east to west.
- Excavate a trench 3 feet deep by 2 feet wide the length of the excavation.
- Drape geo-fabric (Mirafi 140-N or equivalent) type sheeting along the length of the excavation trench so that it is flush against the bottom of the trench and comes up along each sidewall with 1.5 feet excess for overlap.
- Fill the trench with approximately 1 foot 8 inches to 1 foot 10 inches of gravel the length of the excavation. Leaving approximately 1 foot 2 inches to 1 foot 4 inches of space below the top of the existing slab.
- Place 4 inch perforated pipe the length of the trench. There should be a connection on the west end for a vent riser. Each connection of the pipe should be firmly sealed.
- Place approximately 4 inches to 6 inches of gravel the length of the trench covering the sides and top of the perforated pipe with approximately 2 inches of gravel.
- Wrap the geo-fabric type sheeting to overlap with the opposite side. There should be a minimum of 6 inches of overlap that should be sealed with polyethylene compatible tape the length of the trench.
- Place 2 inches of gravel and level the gravel to leave approximately 6 inches of space below the top of the existing slab.
- Place a double layer of 10-mil thick polyethylene sheeting (barrier) covering the width and length of the trench. Edges of the barrier should be "tucked" into the gravel and underneath the existing slab (minimum 2" under lap).
- The vent riser and double layer of 10-mil polyethylene sheeting intersection should be properly sealed with heavy-duty polyethylene compatible tape.
- Clear the Polyethylene sheeting of any excess gravel or debris for placement of concrete flush to existing slab.

Site Maps:

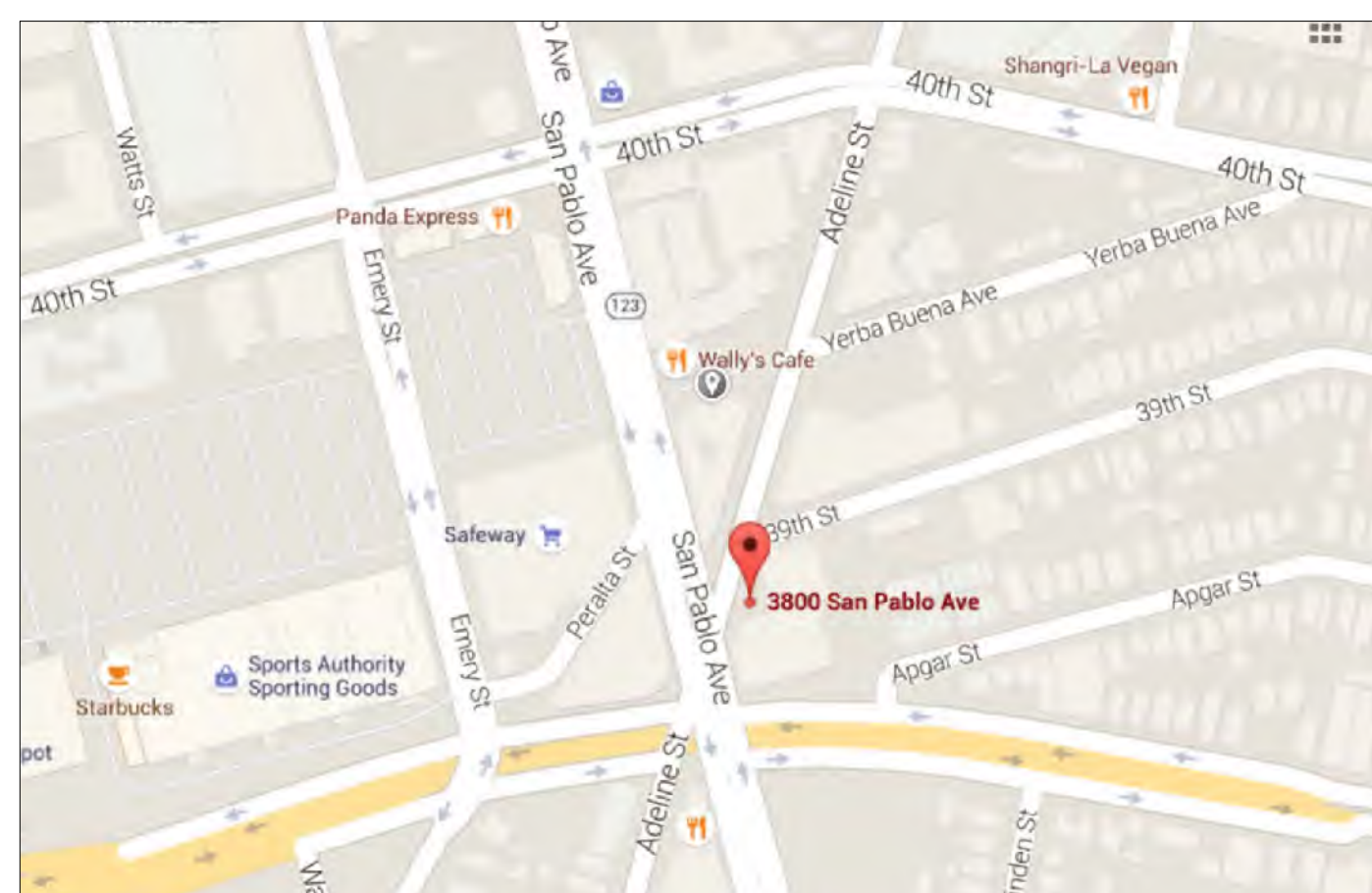

SITE ADDRESS:
3800 SAN PABLO AVENUE
EMERYVILLE, CA
OWNER: HOLIDAY DEVELOPMENT

MEMBRANE MITIGATION PLANS



Rev.: XXX
Date: 01.19.16
Scale: Not to Scale
Drawn: AIR
Job: HOLIDAY
Sheet:

SHT. 1

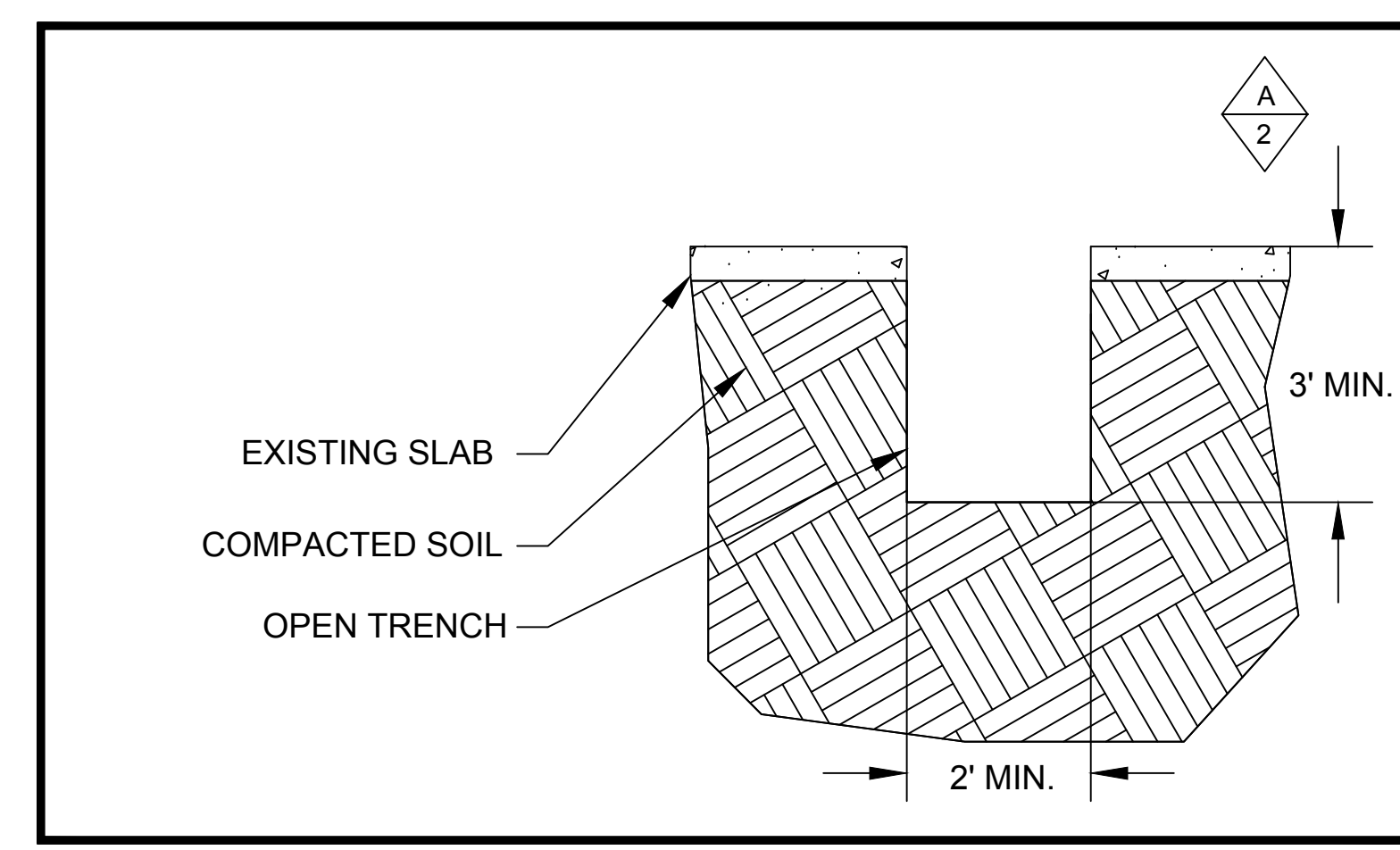
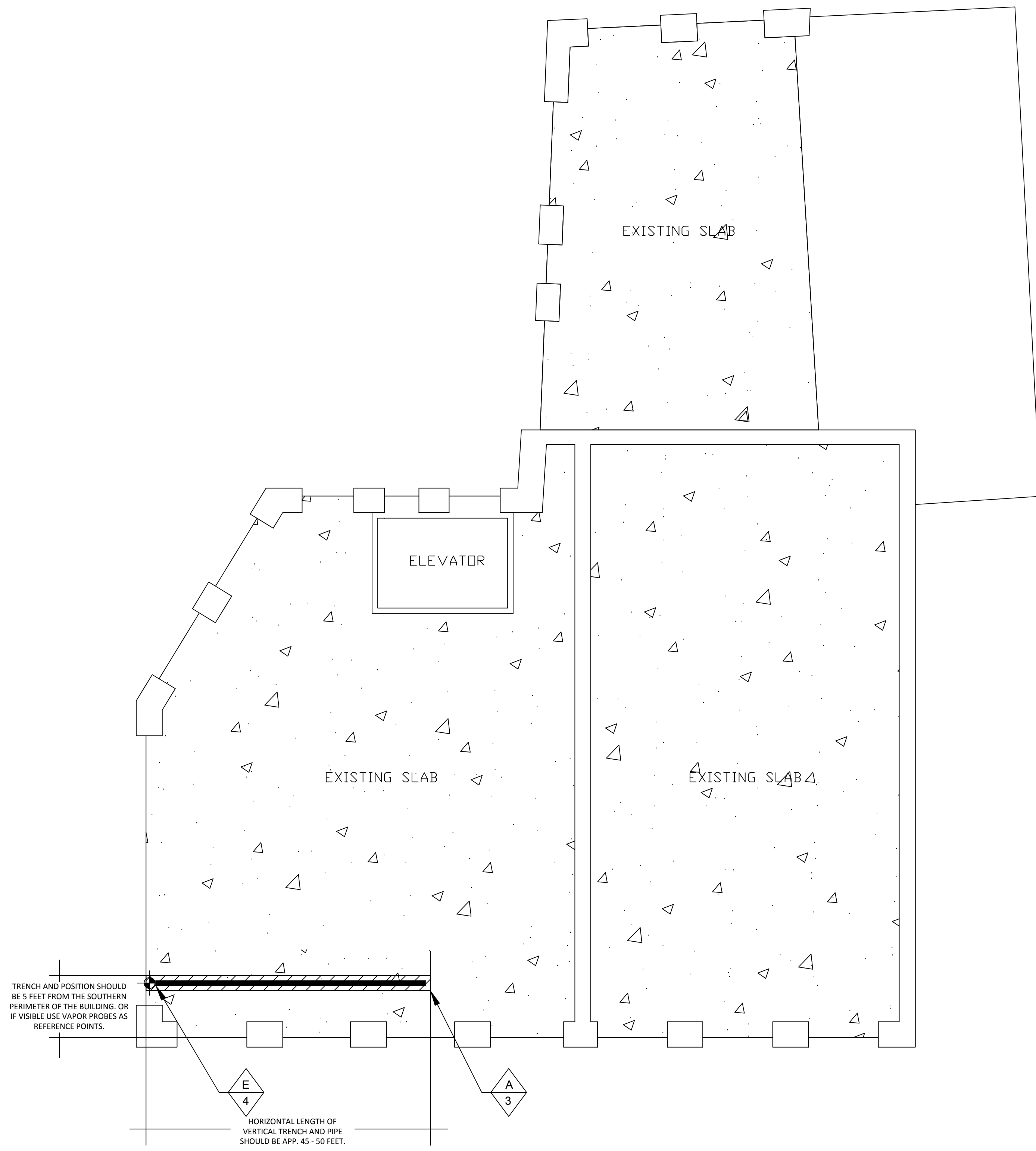

STEP 1 - CUT OUT A STRAIGHT LINE STRIP OF EXISTING SLAB, APPROXIMATELY 2' WIDE FOR APPROXIMATELY 55' EAST TO WEST

STEP 2 - EXCAVATE A TRENCH 3' DEEP BY 2' WIDE THE LENGTH OF THE EXCAVATION

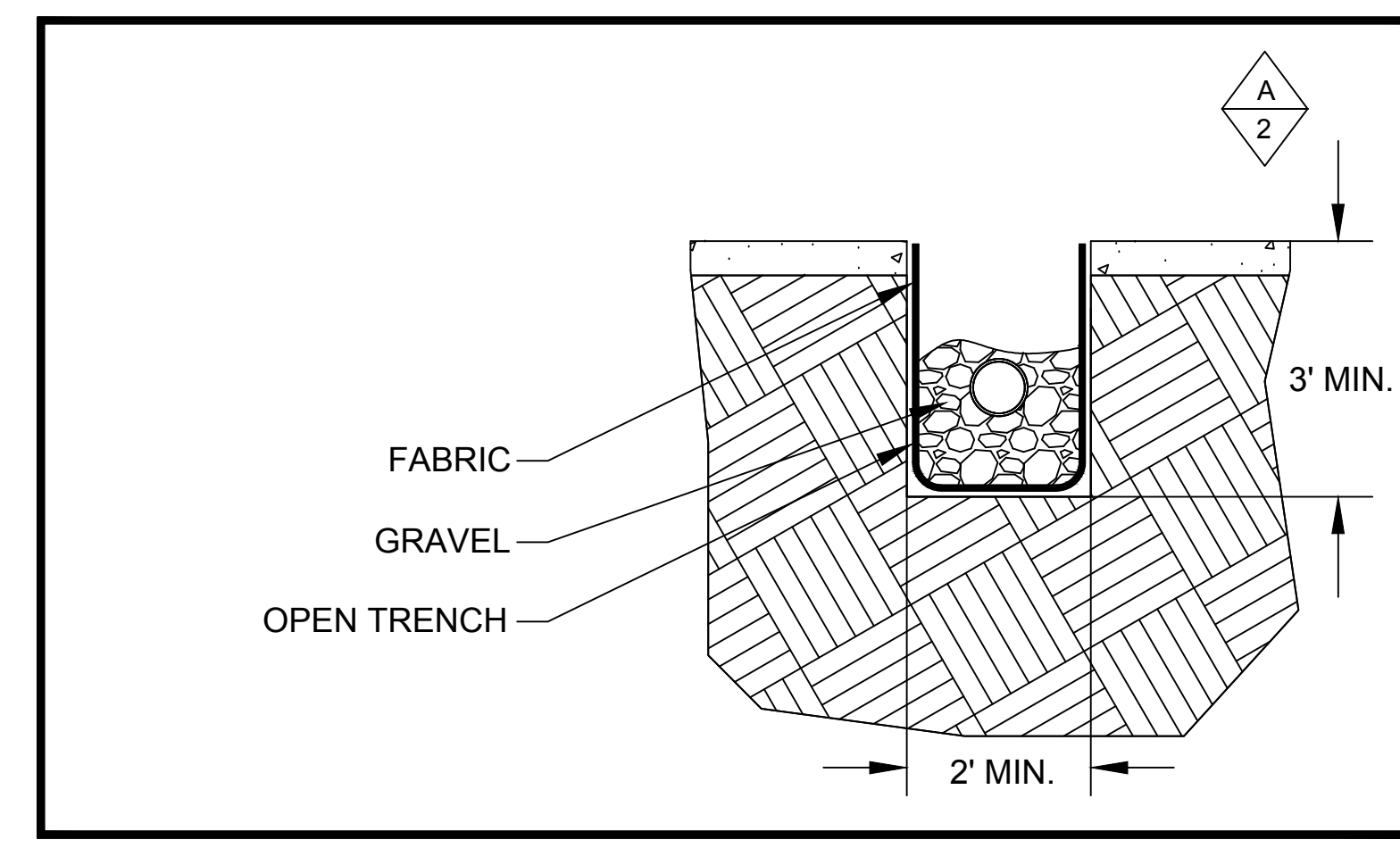

STEP 3 - DRAPE BREATHABLE SHEETING ALONG THE LENGTH OF THE EXCAVATION TRENCH SO THAT IT IS FLUSH AGAINST THE BOTTOM OF THE TRENCH AND COMES UP ALONG EACH SIDE WALL WITH 1.5' EXCESS FOR OVERLAP

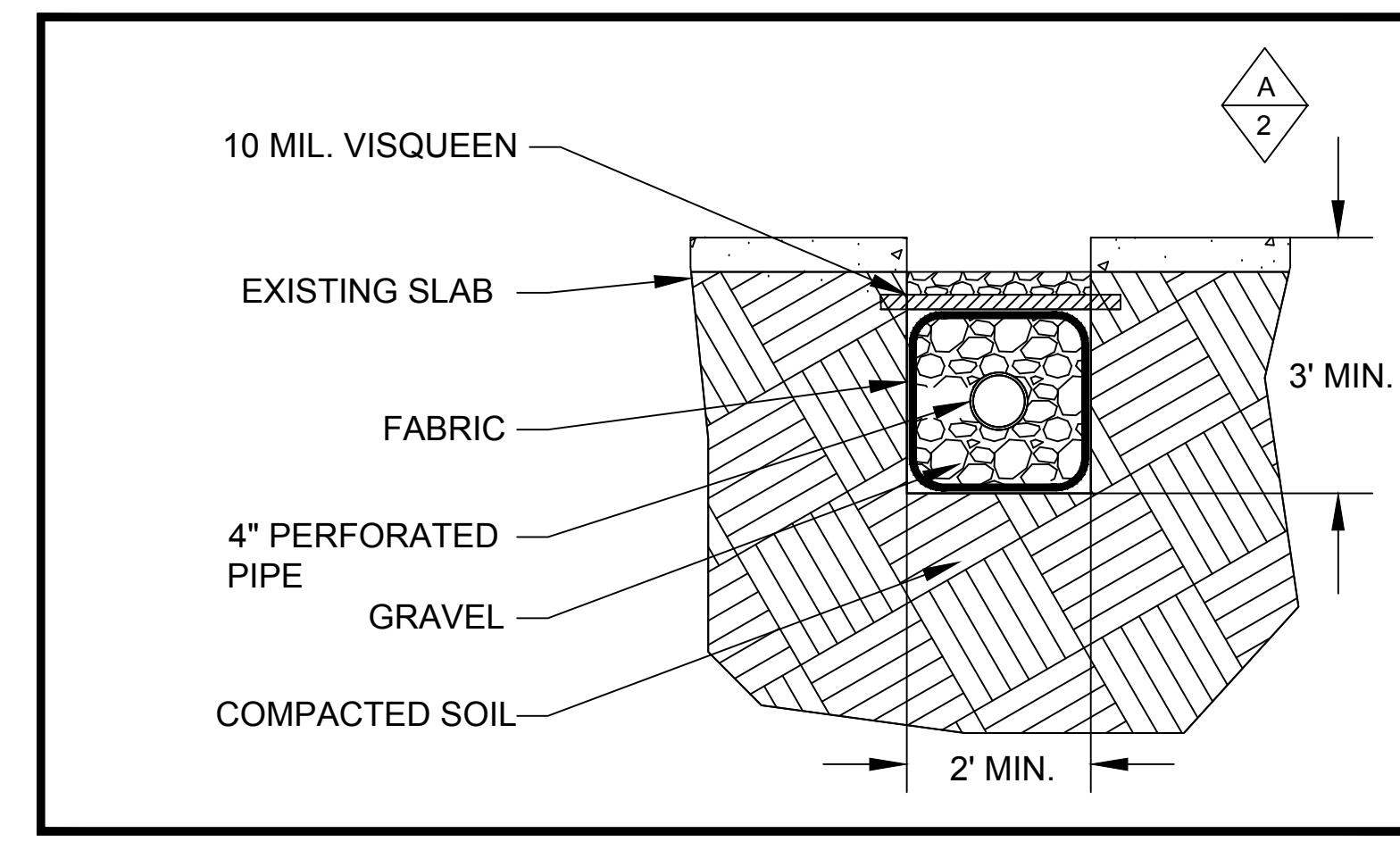

STEP 4 - FILL THE TRENCH WITH APPROXIMATELY 1'8" TO 1'10" GRAVEL THE LENGTH OF THE EXCAVATION. LEAVING APPROXIMATELY 1'2" TO 1'4" OF SPACE FLUSH TO EXISTING SLAB.

STEP 5 - PLACE 4" PERFORATED PIPE THE LENGTH OF THE TRENCH. THERE SHOULD BE A CONNECTION ON THE WEST END FOR A VENT RISER. EACH CONNECTION OF THE PIPE SHOULD BE FIRMLY SEALED.

STEP 6 - PLACE APPROXIMATELY 4" TO 6" OF GRAVEL THE LENGTH OF THE TRENCH COVERING THE SIDES AND TOP OF THE PERFORATED PIPE WITH APPROXIMATELY 2" OF GRAVEL.

STEP 7 - WRAP THE BREATHABLE SHEETING TO OVERLAP WITH THE OPPOSITE SIDE. THERE SHOULD BE A 6" OVERLAP THAT SHOULD BE SEALED WITH ADHESIVE TAPE THE LENGTH OF THE TRENCH.

STEP 8 - PLACE 2" OF GRAVEL AND LEVEL GRAVEL TO LEAVE APPROXIMATELY 6" OF SPACE FLUSH TO EXISTING SLAB.

STEP 9 - PLACE THE 10-MIL VISQUEEN BARRIER COVERING THE WIDTH AND LENGTH OF THE TRENCH. EDGES OF THE BARRIER SHOULD BE "TUCKED" INTO THE GRAVEL AND UNDERNEATH THE EXISTING SLAB.

STEP 10 - THE VENT RISER AND 10-MIL VISQUEEN INTERSECTION SHOULD BE PROPERLY SEALED WITH HEAVY-DUTY ADHESIVE TAPE.

STEP 11 - CLEAR THE VISQUEEN BARRIER OF ANY EXCESS GRAVEL OR DEBRIS FOR PLACEMENT OF CONCRETE FLUSH TO EXISTING SLAB.

Legend:

- VENT RISER LOCATIONS
- PERFORATED PIPE
- SLAB
- AREA OF WORK
- REPAIR DETAIL PER LOCATION
- VENT RISER LOCATION AND DETAIL

NOTE: PERFORATED PIPE TO BE PLACED 5' FROM THE SOUTHERN WALL OF THE BUILDING AT THE DIRECTION OF GRAFCON, THE ENVIRONMENTAL CONSULTANTS OF RECORD

NORTH

APPROXIMATE SCALE

SITE ADDRESS:
3800 SAN PABLO AVENUE
EMERYVILLE, CA
OWNER: HOLIDAY DEVELOPEMENT

MEMBRANE
MITIGATION PLANS



Rev.:	XXX
Date:	05.04.16
Scale:	Not to Scale
Drawn:	AJR
Job:	HOLIDAY
Sheet:	

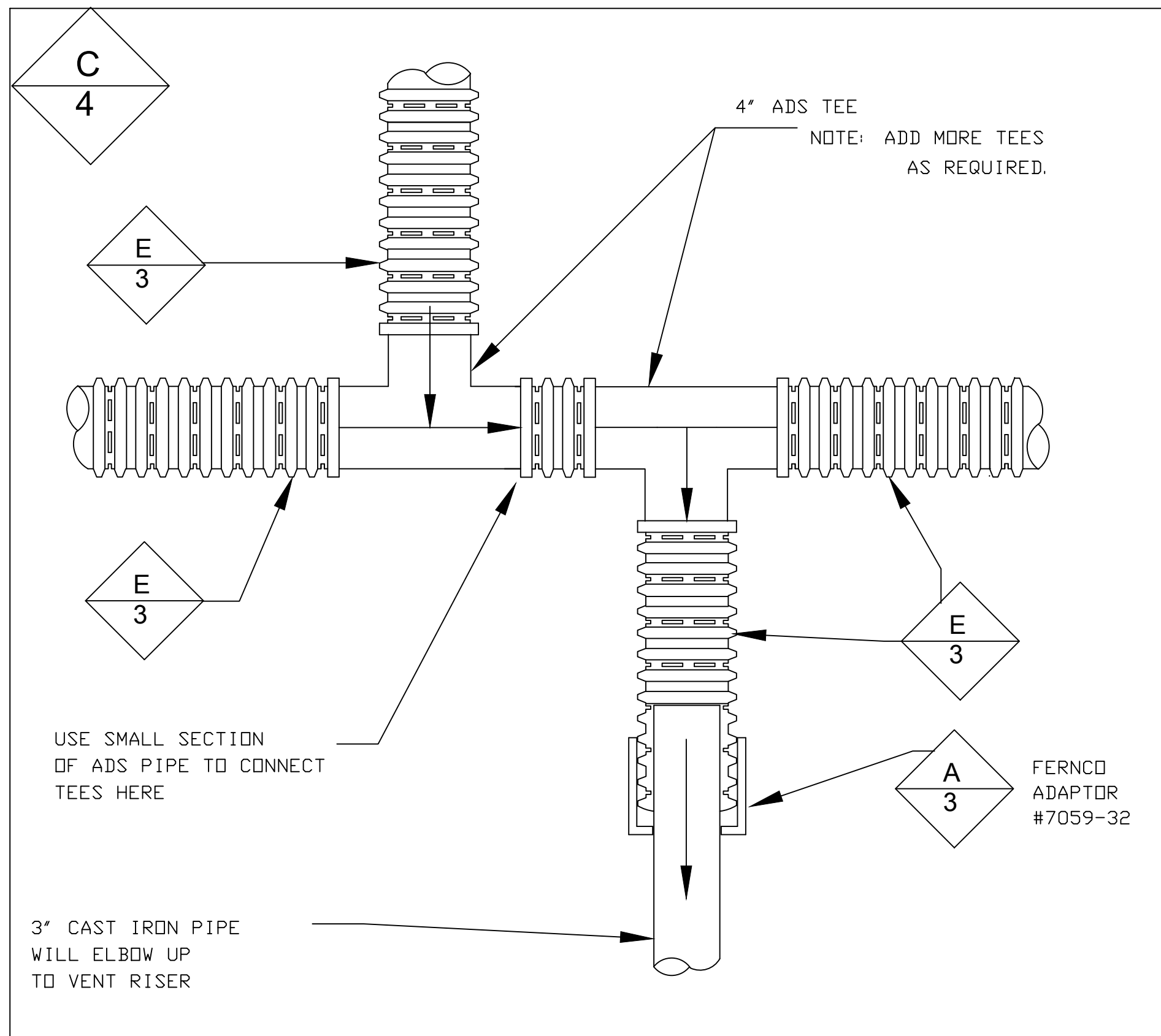

ADS GAS PIPE COLLECTION ASSEMBLY

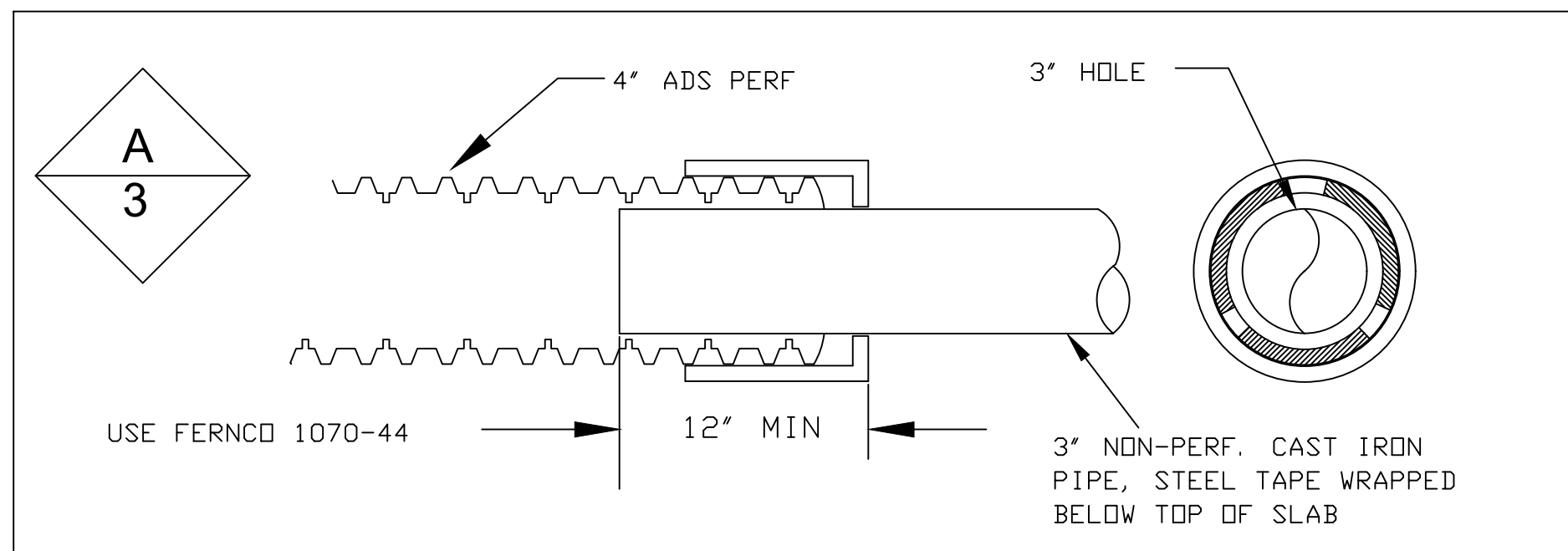

ADS/CAST IRON TRANSITION FITTINGS AT VENT TO ROOF

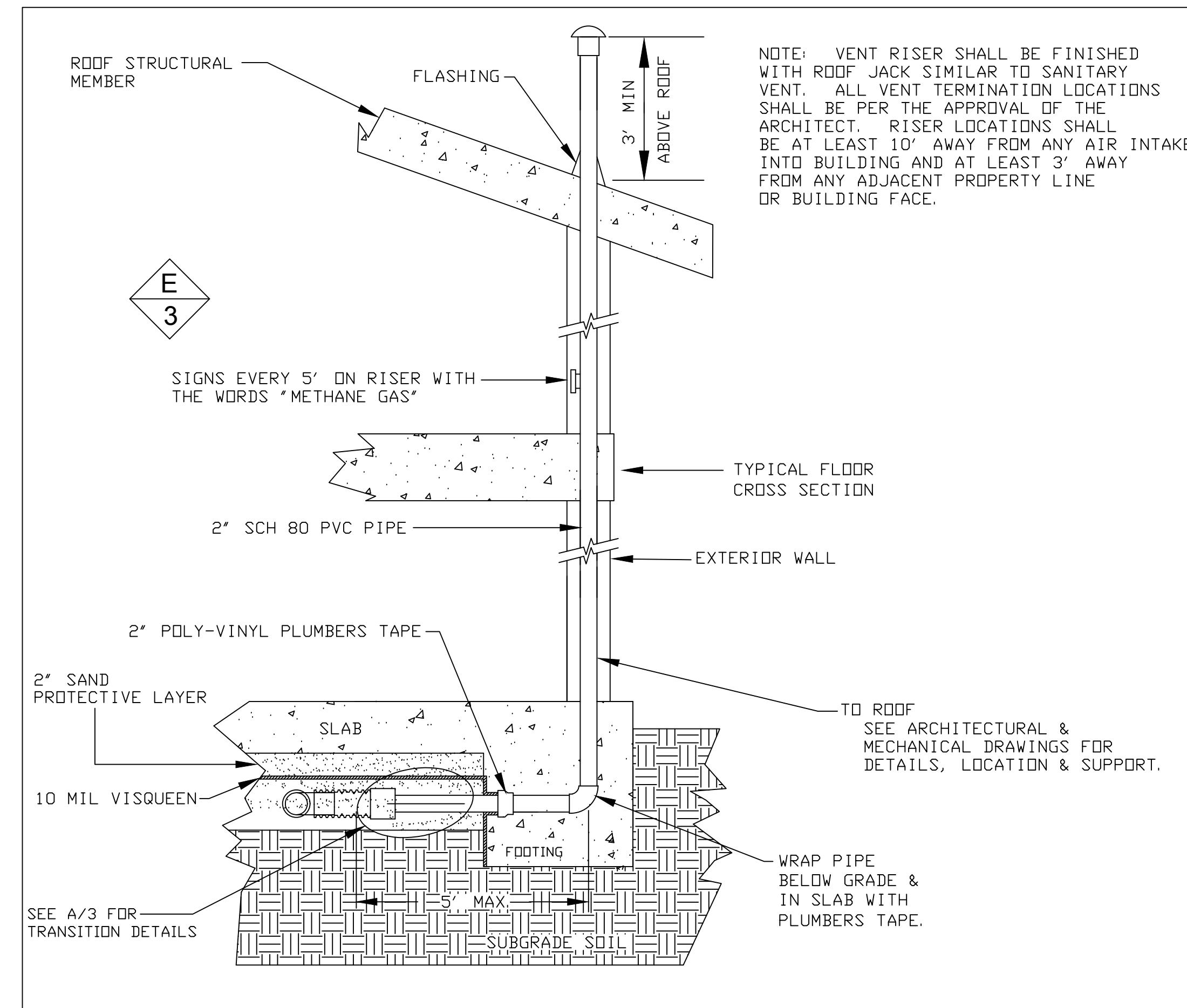

TYPICAL VENT TO ROOF

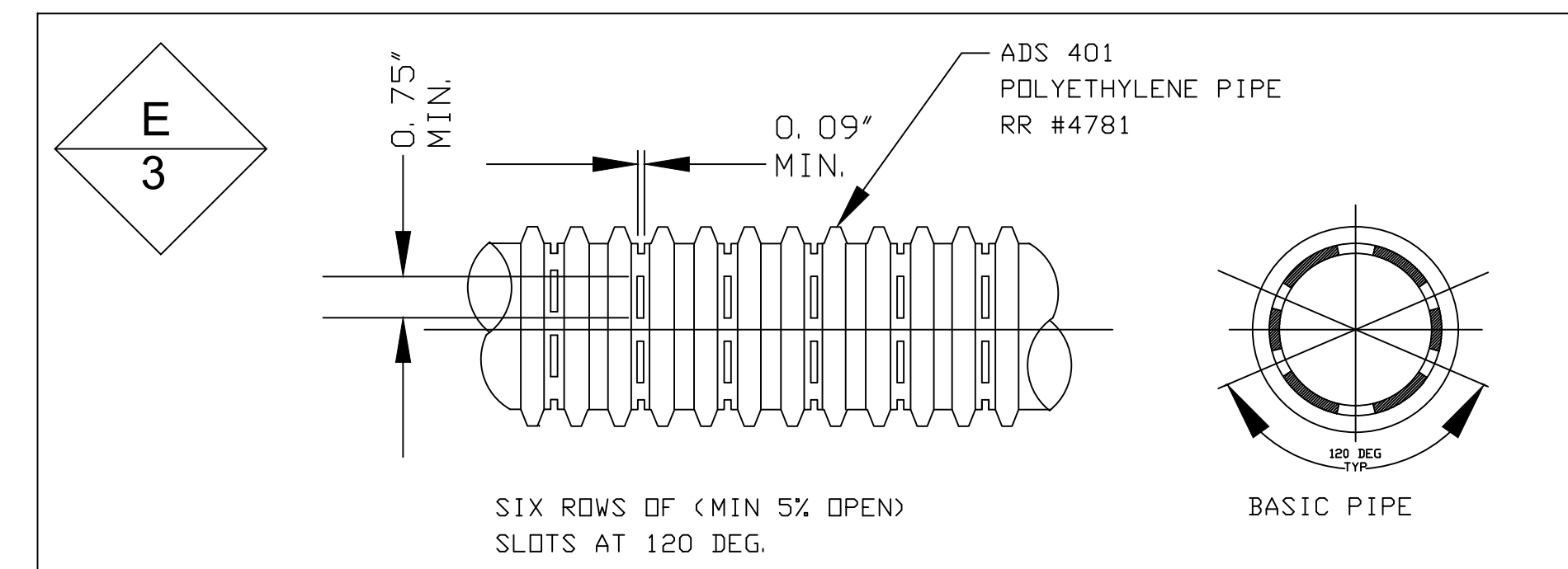

ADS METHANE PIPE DETAIL

SITE ADDRESS:
3800 SAN PABLO AVENUE
EMERYVILLE, CA
OWNER: HOLIDAY DEVELOPMENT

MEMBRANE
MITIGATION PLANS



Rev.: XXX
Date: 01.19.16
Scale: Not to Scale
Drawn: AIR
Job: HOLIDAY
Sheet: