

August 1, 2012

RECEIVED

9:24 am, Aug 06, 2012

Alameda County
Environmental Health

Mr. Jerry Wickham
Senior Hazardous Materials Specialist
Alameda County Environmental Health Services
Environmental Protection, Local Oversight Program
1131 Harbor Bay Parkway, Suite 250
Alameda, CA 94502-6577

**Subject: Letter of Transmittal for Additional Sub-Slab Soil Vapor Investigation
Workplan
Kragen Auto Supply (Former Grand Auto #43)
4240 International Boulevard (East 14th Street)
Oakland, California 94601
ACEH Fuel Leak Case No. RO0002483
GeoTracker Global ID No. T06019705075**

Dear Mr. Wickham:

As required in your letter of June 5, 2012 regarding the above-referenced subject site, we submit this transmittal letter and accompanying work plan to evaluate the potential for soil vapor intrusion, provide additional information regarding the historical removal of underground storage tanks and conveyance piping, and resume biennial groundwater monitoring.

I declare under penalty of perjury, that the information and/or recommendations contained in the attached document or report is true and correct to the best of my knowledge.

Sincerely,

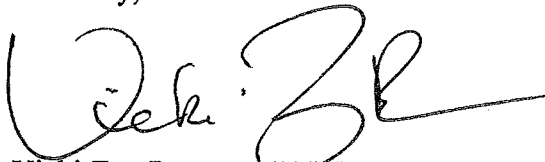

Vicki ZumBrunnen, REM
Environmental Project Supervisor



AllWest Environmental, Inc.

Specialists in Physical Due
Diligence and Remedial Services

530 Howard Street, Suite 300
San Francisco, CA 94105
Tel 415.391.2510
Fax 415.391.2008

ADDITIONAL SUB-SLAB SOIL VAPOR INVESTIGATION

**O'Reilly Auto Parts
(Former Grand Auto #43)
4240 International Boulevard (East 14th Street)
Oakland, California 94601**

**ACHCS Case # RO0002483
Geotracker Global ID # T06019705075**

PREPARED FOR:

PACCAR, Inc.
Corporate Environmental Department
P.O. Box 1518
Bellevue, WA 98009

ALLWEST PROJECT 12088.23
August 1, 2012

PREPARED BY:

Leonard P. Niles, PG, CHG
Senior Project Manager

REVIEWED BY:

Marc D. Cunningham REA
President

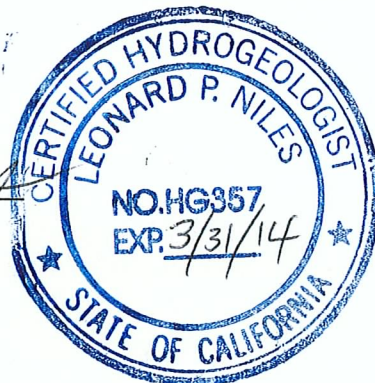



TABLE OF CONTENTS

I.	INTRODUCTION	Page 1
II.	PROJECT BACKGROUND	Page 2
	A. Site Location and Description.....	Page 2
	B. Site Geology and Hydrogeology.....	Page 2
	C. Previous Investigations and Remedial Actions.....	Page 4
III.	PURPOSE AND SCOPE OF WORK.....	Page 10
IV.	INVESTIGATIVE ACTIVITIES	Page 11
	A. Permitting.....	Page 11
	B. Health and Safety Plan.....	Page 11
	C. Underground Utility Inspection and Conduit Survey	Page 11
	D. Sub-Slab Soil Vapor Probe Installation	Page 12
	E. Soil Vapor Sampling.....	Page 13
V.	QUALITY ASSURANCE / QUALITY CONTROL PROGRAM	Page 14
	A. Sample Preservation, Storage and Handling.....	Page 14
	B. Chain-of-Custody Program.....	Page 14
VI.	ANALYTICAL METHODS	Page 14
VII.	REPORT PREPARATION.....	Page 15
VIII.	PROJECT STAFF AND SCHEDULE	Page 15
IX.	LIMITATIONS.....	Page 15
X.	REFERENCES	Page 16

FIGURES

- Figure 1: Site Location Map
- Figure 2: Site Plan with Boring and Well Locations
- Figure 3: Soil Vapor Analytical Summary, January 4, 2012
- Figure 4: Proposed Sub-Slab Soil Vapor Probe Locations

APPENDIX

- Appendix A: ACHCS Letter of June 5, 2012
- Appendix B: Standard Operating Procedure - Installation and Extraction of the Vapor Pin™
- Appendix C: Standard Soil Vapor Sampling Procedures, Schematics and Field Forms
- Appendix D: General Conditions and Authorization for Reliance



AllWest Environmental, Inc.

Specialists in Physical Due
Diligence and Remedial Services

530 Howard Street, Suite 300
San Francisco, CA 94105
Tel 415.391.2510
Fax 415.391.2008

ADDITIONAL SUB-SLAB SOIL VAPOR INVESTIGATION

**O'Reilly Auto Parts
(Former Grand Auto #43)
4240 International Boulevard (East 14th Street)
Oakland, California 94601**

**ACHCS Case # RO0002483
Geotracker Global ID # T06019705075**

I. INTRODUCTION

AllWest Environmental, Inc. (AllWest) has prepared this workplan describing tasks to further characterize sub-slab soil vapor concentrations of volatile organic compounds (VOCs) inside the former Grand Auto # 43 facility (the subject site) referenced above. This proposed work will be performed in response to a request by the Alameda County Health Care Services Agency, Environmental Health Services (ACHCS/ACEH) in their letter of June 5, 2012 to further assess potential indoor soil vapor intrusion issues identified during the previous subsurface investigation conducted by AllWest during January 2012.

The purpose of the proposed work is to further evaluate potential impact by soil vapor intrusion of VOCs to indoor air quality at the subject site in the vicinity of the former car wash sump by installation and sampling of sub-slab soil vapor probes. This work will be completed after approval and with oversight of the ACHCS. The primary goal is to close data gaps and enable case closure as a low risk solvent plume site.

This work plan briefly summarizes the site setting and background including previous investigations conducted at the property.

II. PROJECT BACKGROUND

A. Site Location and Description

The approximately 1.2 acre former Grand Auto retail facility is located at the northwest corner of High Street and International Boulevard (formerly 14th Street) in Oakland, California. The site currently is used as an O'Reilly Auto Parts store.

The site was used as a dance hall in 1903. Site use between 1903 and 1946 is unknown. Circa 1946, an L-shaped building was constructed on the site. This building was used as office space and for auto repair and painting. The date of demolition of this building is not known. In 1960 or 1961, the present building was constructed for use as a Safeway grocery store.

Grand Auto occupied the building in 1971, installed gasoline pump islands and three 10,000-gallon gasoline underground storage tanks (USTs) for retail gasoline sales, and a car wash with an associated drainage sump. The gasoline service station and car wash operated from circa 1972 to 1986. The USTs were removed in August 1986. The car wash drainage sump was removed in August 1992. In October 1993, the remaining fuel conveyance piping associated with the former USTs was excavated and removed from the site.

Between 1992 and 2012, site environmental conditions were characterized via soil borings and groundwater monitoring wells. A site location map and site plan are presented as Figures 1 and 2, respectively.

B. Site Geology and Hydrogeology

The property is located on the East Bay Plain along the eastern slopes of the San Francisco Bay and immediately west of the East Bay Hills. The subject site is located at an elevation of approximately 30 feet above mean sea level (msl). The topographic gradient in the site vicinity is to the south-southwest toward San Francisco Bay.

Data from previous site borings advanced during subsurface investigations conducted during the 1990s and 2012 indicate the property is underlain by an irregularly layered sequence of clayey to silty gravelly sand and sandy to clayey gravel lenses separated by clayey to sandy silt and silty to sandy clay layers to a depth of approximately 35 feet below ground surface (bgs). As much as 20 feet of imported fill material has been reported at some areas of the site. However, the site is not in an area mapped as artificial fill [Hart Crowser, *Preliminary Site Investigation Report*, November 20, 1992 (Hart Crowser, 1992b) and *Supplemental Site Investigation* June 18, 1993 (Hart Crowser, 1993), and AllWest, *Soil Vapor and Subsurface Investigation Report*, March 16, 2012 (AllWest, March 2012b)].

The loose gravelly fine sand encountered in boring GP-2, located within the former UST excavation (Figure 2), to a depth of approximately 6.5 to 10 feet bgs is inconsistent with lithology encountered in other previous borings at the subject site, and appears to be UST excavation backfill, as does the underlying clayey gravel extending to 12 feet bgs. A sharply defined contact at 12 feet bgs between clayey gravel fill material and native sandy clay below probably defines the base of the former UST excavation. The clayey gravel layer was saturated at a depth of approximately 10.4 feet bgs; this water level did not rise after the first encounter, indicating a localized shallow unconfined perched water-bearing zone within the former UST excavation backfill confined by low permeability native clay below. This perched zone appears to be consistent with those encountered in several other previous borings, and does not constitute a continuous groundwater-bearing zone across the subject property (AllWest, March 2012b).

Shallow perched water-bearing zones were encountered at 14.5 feet bgs and 9.5 feet bgs in borings B-1 and B-2, respectively. Very moist to wet zones were encountered during the drilling of borings B-4 at approximately 11.5 to 20 feet bgs, B-5 at approximately 11.5 to 15.5 feet bgs, B-7 (MW-1) at approximately 9.5 to 10.5 feet bgs, and GP-1 at approximately 16.5 to 23.5 feet bgs, although free water was not encountered. These perched water-bearing and moist to wet zones indicate a possible discontinuous zone of perched groundwater. No other wet or perched zones were noted in other borings drilled at the subject property (Hart Crowser, 1992b and 1993).

Below the silt and clay layers, a fairly uniform layer of silty to gravelly sand was encountered in all borings at approximately 31 to 37 feet bgs, and extended to the total explored depth of approximately 46 feet bgs in most borings, except for a lower clay layer encountered from approximately 44 to 46 feet bgs in borings MW-3 and MW-4. Unconfined groundwater was first encountered within this sand layer at approximately 34.5 to 37 feet bgs in borings B-5, B-7 (MW-1), MW-2, MW-3, MW-4 and GP-1. Although first encountered groundwater within this sand layer was unconfined when these borings were drilled near the end of a prolonged drought period in the early 1990s, increased precipitation has since resulted in static water levels rising to approximately 23 to 24 feet bgs; therefore groundwater within this sand layer is now confined. A relatively thick silty to sandy clay or clayey silt confining layer, which overlies the sand layer containing the first encountered groundwater, appears to be present in all of the deeper subject site borings. The static depth of confined groundwater encountered in GP-1 of approximately 20.6 feet bgs during January 2012 was approximately 3 to 4 feet higher than depth to water measured in the onsite monitoring wells during the December 20, 2011 monitoring event (Hart Crowser, 1992b and 1993, and AllWest, March 2012b).

The groundwater gradient in the site area is very flat, thus the determination of the groundwater flow direction is difficult to assess. Groundwater flow direction in the vicinity of the site has historically fluctuated, but was generally calculated to

be to the east, at a very flat gradient, with the exception of the June 2008 monitoring event measurement which was to the west. The regional groundwater flow direction is to the southwest from the Oakland Hills towards San Francisco Bay, concurrent with the topography. The historical fluctuations in gradient direction are not considered significant due to the very small differences in groundwater elevations measured (AllWest, March 2012b).

The depth to groundwater during the last monitoring event in December 2011 ranged between 22.51 feet below ground surface (bgs) and 24.13 feet bgs, an average decrease of 0.4 feet since the previous June 2008 event. The local groundwater flow direction measured during the 2011 monitoring event was generally towards the east at a gradient of approximately 0.001 feet/foot [AllWest, *2011 Groundwater Monitoring Report*, March 16, 2012 (AllWest, March 2012a)].

C. Previous Investigations and Remedial Actions

This workplan briefly summarizes the site background including previous investigations and remediation activity conducted at the property. More detailed descriptions of site conditions and previous investigations from 1992 to 1996 are presented in the Hart Crowser, Inc. (Hart Crowser) reports titled: *Sampling and Analysis Plan, Grand Auto/Super Tire Facilities*, dated July 5, 1992 (Hart Crowser, 1992a), *Preliminary Site Investigation Report*, dated November 20, 1992 (Hart Crowser, 1992b), *Supplemental Site Investigation*, dated June 18, 1993 (Hart Crowser, 1993), *Quarterly Status Report*, dated January 14, 1994 (Hart Crowser, 1994a), *Quarterly Status Report*, dated November 9, 1994 (Hart Crowser, 1994b), *Facility Closure Report*, dated February 16, 1996 (Hart Crowser, 1996a), *Risk Assessment*, dated October 8, 1996 (Hart Crowser, 1996b).

More detailed descriptions of site conditions and previous investigations from 2000 to 2012 are presented in the AllWest reports titled: *Site Closure and Groundwater Monitoring Report*, dated August 15, 2000 (AllWest, 2000), *Annual Groundwater Monitoring and Well Destruction Report*, dated August 27, 2001 (AllWest, 2001), *Biennial Groundwater Monitoring Report*, dated July 28, 2008 (AllWest, 2008), *Soil Vapor Investigation and Groundwater Monitoring Work Plan*, dated April 15, 2011 (AllWest, 2011a), *Soil and Groundwater Investigation Workplan Addendum*, dated July 15, 2011 (AllWest, 2011b), *2011 Groundwater Monitoring Report*, dated March 16, 2012 (AllWest, March 2012a), and *Soil Vapor and Subsurface Investigation Report*, dated March 16, 2012 (AllWest, March 2012b). Historical boring and monitoring well locations are shown on Figure 2.

Underground Tank Removal

Three 10,000-gallon gasoline fuel underground storage tanks (USTs) located northeast of the fuel dispenser islands at the subject site were removed in August

1986 following failure of a leak detection test. AllWest was unable to locate any agency or consultant UST removal reports, or laboratory analytical data of any confirmatory soil or water samples (AllWest, 2011b).

In July 1992, Hart Crowser performed a site investigation including drilling of two borings (B-4 and B-5) in an assumed vicinity of the former location of the USTs incorrectly located southwest of the dispenser islands (Figure 2). Analyses of soil samples from these borings did not indicate significant petroleum hydrocarbon concentrations (Hart Crowser, 1992b).

Drainage Sump Removal and Installation of MW-1

The car wash drainage sump and surrounding soil were removed on August 7, 1992. Analyses of the soil sample collected from beneath the sump indicated the presence of low concentrations of total petroleum hydrocarbons as gasoline and diesel (TPH-g and TPH-d), and VOCs including toluene, ethylbenzene, xylenes, and tetrachloroethene (PCE). A groundwater monitoring well, MW-1 (boring B-7), was installed approximately 10 feet southwest of the sump, in a down to cross gradient direction (Figure 2), (Hart Crowser, 1992b).

Groundwater Well Installations of MW-2 through MW-4 and HC-1

During April 1993, Hart Crowser drilled five soil borings (B-8 through B-12) and converted three of them to underground monitoring wells, MW-2 (B-10), MW-3 (B-11) and MW-4 (B-12) at the subject site. A groundwater monitoring well, HC-1, was also installed at this time at the adjacent, former Super Tire Facility. Two of the soil borings (B-8 and B-9) were completed in the area of the former car wash sump (Figure 2). Soil samples from these two borings indicated that the TPH-g, TPH-d and PCE detected immediately below the sump in were neither laterally nor vertically widespread (Hart Crowser, 1993).

Conveyance Piping Removal

In October 1993, fuel conveyance piping associated with the former underground fuel storage tanks was excavated and removed from the site. Verification soil samples were collected at a depth of 2.5 feet bgs from the base of the excavation at four locations, PGA-1, PGA-2, PGA-3 and PGA-4 (Figure 2). Each sample was analyzed for TPH-g and benzene, toluene, ethylbenzene, and xylenes (BTEX). TPH-g and BTEX were not detected in any of the samples analyzed (Hart Crowser, 1994a).

Facility Closure Report for Grand Auto

Hart Crowser recommended case closure for the site in February 1996 since the environmental issues associated with potential onsite sources of chemicals had been addressed. Halogenated VOCs remained in site groundwater, but these were

unrelated to the onsite sources that have been addressed and likely to be the result of releases at one or more of the numerous offsite potential sources located in the immediate vicinity of the site. Hart Crowser recommended abandonment of the remaining groundwater monitoring wells after closure certification approval by ACHCS and Regional Water Quality Control Board (RWQCB) (Hart Crowser, 1996a).

Hart Crowser 1996 Risk Assessment and ACHCS 1996 Closure Letter for Site Soils

In order to obtain site closure for the soil portion of the site, Hart Crowser completed an ASTM, Tier 1, Risk Based Corrective Action (RBCA) assessment for the subject property in October 1996). The risk assessment was prepared to meet the closure requirements of the ACHCS and the RWQCB. No on-site concentrations were noted above the calculated Risk-Based Screening Levels (RBSLs) in subsurface soil or from vapors in soil from groundwater under either the residential or industrial exposure scenario. Therefore, Hart Crowser concluded that the residual presence of chemicals in subsurface soils does not pose an unacceptable risk to human health under current or potential future use scenarios, and the site satisfied the conditions for regulatory site closure from a human health risk perspective (Hart Crowser 1996b). Based on the Hart Crowser risk assessment (1996b), ACHCS concluded in a December 30, 1996 letter to PACCAR that the soils on-site do not pose a threat to public health.

AllWest 2000 Site Closure and Groundwater Monitoring Report

In 1999 and 2000 AllWest completed the following tasks at the subject property:

- The redevelopment and sampling of the five on-site groundwater wells during the November 1999;
- An update of the previously completed ASTM Tier 1 risk assessment by discounting the groundwater ingestion pathway by the completion of a 1/2 mile radius well survey;
- The comparison of the maximum on-site groundwater contamination concentrations to recently developed, Oakland specific, Tier 1 risk based screening levels (RBSLs) to document that this is a low risk case and candidate for “No Further Action” status by the ACHCS; and
- The destruction of monitoring well MW-3 on May 25, 2000 due to motor oil leakage into the vault box from parked automobiles, and the drilling and installation of replacement monitoring well MW-3A outside of the parking area (Figure 2).

Petroleum hydrocarbons were not considered an unacceptable risk to human health or the environment based on low or nondetectable concentrations of constituents. The chlorinated solvent concentrations were noted to generally decrease from the November 1999 sampling as compared to the previous sampling period event conducted in 1996. AllWest concluded that the likely source of the bulk of the chlorinated solvents is the existing or former dry cleaners located southeast of the subject property.

As part of the 1999/2000 investigation activities, AllWest reviewed and updated the previously completed ASTM, Tier 1 RBCA assessment for the subject property (Hart Crowser 1996b). No groundwater supply wells for industrial, agricultural, municipal or residential uses were identified within 1/2 mile of the subject property. Maximum VOC concentrations reported from the site groundwater were at least one order of magnitude lower than their respective Oakland Tier 1 RBSLs.

AllWest concluded in their *Site Closure and Groundwater Monitoring Report*, dated August 15, 2000 that the results of the November 1999 groundwater sampling event indicated that the shallow groundwater of the subject property is impacted with chlorinated solvents. Although data did not indicate a clear source area, AllWest concluded the likely source of the bulk of the chlorinated solvents was the existing or former dry cleaners located southeast of the subject property. Based on site specific results and current health risk based action levels, AllWest concluded that it is unlikely that the residual contamination in the site groundwater posed an unacceptable risk to human health or the environment. AllWest recommended that ACHCS grant “no further action status” for the residual chlorinated solvents in the groundwater of the subject property and requested approval to abandon the existing five on-site groundwater wells (AllWest, 2000).

ACHCS November 2000 No Further Remediation Letter

ACHCS reviewed AllWest’s August 2000 report and noted that they and the RWQCB do not grant closure for sites with groundwater impacted above MCLs. However, ACHCS did state that active remediation for the residual chlorinated solvents in the soil or groundwater is not required and requested the annual sampling of wells MW-1 through MW-4. ACHCS also added that groundwater well, HC-1, located on the former Super Tire facility may be decommissioned at this time. AllWest abandoned groundwater monitoring well, HC-1 in June 2001 (AllWest 2001).

Groundwater Monitoring 2001 to 2011

AllWest conducted annual groundwater monitoring from 2001 to 2004. The ACHCS in their letter of November 7, 2005 directed groundwater monitoring be conducted on a biennial basis (every two years). AllWest conducted biennial

groundwater monitoring during 2006 and 2008. AllWest requested case closure in the *2008 Biennial Groundwater Monitoring Report*, (AllWest, 2008). The ACHCS responded to the closure request in their letter dated April 15, 2010, stating that closure was being evaluated for commercial use only and that, during the period that the case is under review, groundwater monitoring may be suspended.

The most recent groundwater monitoring event was conducted December 20, 2011 (AllWest, March 2012a). Chlorinated solvents continued to be detected in all wells at the property. PCE was detected in groundwater samples collected from all four monitoring wells, with the highest concentrations in MW-1. Chlorinated solvent concentrations detected in the four wells during the December 2011 monitoring event exceeded RWQCB Environmental Screening Levels (ESLs) as described in *Table F-1a Groundwater Screening Levels (groundwater is a current or potential drinking water resource)* in the *Screening For Environmental Concerns At Sites With Contaminated Soil and Groundwater* (RWQCB, 2008), (AllWest, March 2012b).

Concentrations of chlorinated solvents detected during the December 2011 event generally decreased in MW-1 and MW-3A and increased in MW-2 and MW-4 since the last sampling performed in 2008. The highest concentrations of PCE have historically been detected in MW-1. Slightly lower levels have been detected in MW-3A and MW-4. Significantly lower concentrations of PCE have been detected in MW-2. The PCE breakdown products, trichloroethene (TCE), and cis-1,2-dichloroethene (cis-1,2-DCE) also follow this trend. Based on the spatial distribution of the VOCs detected in site monitoring wells, a single, well defined source for the chlorinated solvents is not apparent (AllWest, 2012a).

Only VOC analysis was performed from the 2001 through 2008 groundwater monitoring events; TPH-g analysis was not performed between the 1999 and 2011 events, and was detected only in a single sample during the 1999 event. TPH-g range compounds were detected in groundwater samples collected from MW-1, MW-3A and MW-4 during the December 2011 sampling event. Since the laboratory chromatograms of the December 2011 (and most of the historical 1993 to 1994) TPH-g detections do not match typical gasoline standards, the detected constituents were probably chlorinated VOCs (mostly PCE) within the TPH-g range (AllWest, 2012a).

Additional Subsurface Investigation 2012

AllWest) conducted a subsurface investigation in January 2012 to characterize current soil and groundwater conditions and potential indoor soil vapor intrusion conditions at the subject site. Six temporary soil vapor probes (SVP-1 through SVP-6) were installed to a depth of 5 feet bgs inside and outside of the building in the vicinity of the former car wash sump (Figure 2). PCE was detected in all six soil vapor samples collected at a maximum concentration of 4,600 micrograms

per cubic meter ($\mu\text{g}/\text{m}^3$) in SVP-2 inside the building adjacent to the former sump. TCE was detected in soil vapor samples collected from SVP-2, SVP-3, SVP-5 and SVP-6 at a maximum concentration of $210 \mu\text{g}/\text{m}^3$ in SVP-3. Low concentrations of other VOCs including BTEX, acetone, 1,3-butadiene, chloroform, dichlorodifluoromethane (Freon 12), ethanol, ethyl acetate, 4-ethyltoluene, isopropyl alcohol (IPA), 4-methyl-2-pentanone (MIBK), naphthalene, propene, 1,2,4-trimethylbenzene and 1,3,5-trimethylbenzene were also detected (AllWest, 2012b). Soil vapor analytical results are summarized in Figure 3.

PCE concentrations in probes SVP-3 and SVP-5 exceeded the corresponding California Regional Water Quality Control Board, San Francisco Bay Region (RWQCB) Environmental Screening Level (ESL) of $1,400 \mu\text{g}/\text{m}^3$ for commercial/industrial land use (RWQCB, *Screening for Environmental Concerns at Sites with Contaminated Soil and Groundwater, Table E*, Interim Final November 2007, revised May 2008), and exceeded the State of California Environmental Protection Agency (CalEPA) California Human Health Screening Level (CHHSL) of $600 \mu\text{g}/\text{m}^3$ for soil vapor at commercial/industrial sites constructed without engineered fill (*Use of California Human Health Screening Levels (CHHSLs) in Evaluation of Contaminated Properties, Table 3*, January 2005, revised September 23, 2010). The PCE concentration in probe SVP-6 exceeded its applicable commercial/industrial CHHSL. None of the other VOCs detected in soil vapor samples exceeded their applicable ESLs or CHHSLs (AllWest, 2012b).

Two soil borings, GP-1 and GP-2, were advanced to total respective depths of 35 and 20 feet bgs using Geoprobe[®] DPT methods on January 5, 2012 in the vicinity of the former USTs in the driveway and parking areas (Figure 2). TPH-d, TPH-mo, VOCs and metals were detected in soil samples at low concentrations not exceeding applicable ESLs, with the exception of nickel slightly exceeding its ESL in one sample. VOCs including PCE, its breakdown product cis-1,2-dichloroethene (cis-1,2-DCE) and carbon disulfide were detected in groundwater samples from GP-1 and GP-2 at concentrations below groundwater ESLs for commercial/industrial land use where groundwater is a potential drinking water resource. TPH-d and TPH-mo were detected in a water sample from GP-2 at concentrations exceeding their respective drinking water ESLs; however, that sample from the isolated shallow perched water-bearing zone within the former UST excavation is not representative of true groundwater at the subject site. Nickel, detected in the groundwater sample from boring GP-1, exceeded the drinking water ESL (AllWest 2012b).

AllWest concluded the highest VOC concentrations detected in soil vapor samples were from the vicinity of the former sump; however, soil vapor intrusion into the building interior is likely not a significant exposure pathway to building occupants, since only one of the three soil vapor samples collected from beneath the building interior floor slab contained PCE at concentrations exceeding the applicable ESL, by less than one order of magnitude. AllWest concluded the

former onsite fuel USTs were not the source of VOCs in the site groundwater, and have not significantly impacted soil or groundwater at the subject property (AllWest, 2012b).

In their letter of June 5, 2012 responding to the AllWest *Soil Vapor and Subsurface Investigation Report* (AllWest, March 2012b), the ACHCS requested additional assessment of potential indoor soil vapor intrusion by sub-slab soil vapor sampling within the subject site building adjacent to the former sump area. The ACHCS required no further investigation in the former UST area.

III. PURPOSE AND SCOPE OF WORK

The purpose of this investigation is to evaluate the extent of VOC-impacted soil vapor and potential for impact by soil vapor intrusion of VOCs to the indoor air quality at the subject site by installing sub-slab soil vapor probes and collecting soil vapor samples within the O'Reilly Auto Parts store near the former car wash sump area, as requested by the ACHCS letter dated June 5, 2012. The scope of work, as proposed, consists of the following tasks:

- 1) Prepare a written workplan to address the technical comments of the ACHCS letter dated June 5, 2012. This will include conducting a sub-slab soil vapor investigation within the subject site building adjacent to the former sump area in response to technical comments 1 and 2. Submit the workplan to the ACHCS for review and concurrence;
- 2) Update site-specific health and safety plan;
- 3) Engage the service of Underground Service Alert (USA) and a private underground utility locator to locate and clear underground utilities within the proposed investigation area so that the potential of accidental damage to underground utilities will be reduced during proposed subsurface investigation. The private utility locator will also attempt to conduct a survey of the suspected sewer line connected to the former sump and other sewer lines within the building. Notify the ACHCS and site tenants, property owners and facility maintenance prior to the start of field work;
- 4) Retain the service of a C-57 licensed drilling contractor for the installation of six semi-permanent sub-slab soil vapor probes within the concrete floor slab of the subject site building in the vicinity of the former sump and sewer line, and in the center of the building. Probe installations will consist of either the Vapor Pin™ type installed within the floor slab, pending ACHCS approval, or sub-slab soil vapor probes to approximately 0.5 to 1 feet bgs in general accordance with CalEPA Department of Toxic Substance Control (DTSC) *Final, Guidance for the Evaluation and Mitigation of Subsurface Vapor Intrusion to Indoor Air (Vapor Intrusion Guidance)*, October 2011;

- 5) Collect six soil vapor samples using SUMMA canisters in general accordance with the DTSC *Advisory – Active Soil Gas Investigations*, April, 2012. Retain one soil vapor sample from each vapor probe, and one ambient leak detection gas sample, for analytical testing. Sub-slab vapor probes will be left in place for future monitoring;
- 6) Maintain soil vapor and ambient leak detect gas samples under chain-of-custody and transport the samples to a Department of Health Services (DHS) certified analytical laboratory (McCampbell Analytical of Pittsburg, California) for chemical analyses. Analyze six soil vapor samples for VOCs using EPA Method TO-15 (mid detection level, full scan) and helium by ASTM D1946, and one leak detection gas sample only helium by ASTM D1946;
- 7) Prepare a written report describing the field activities, summarizing the laboratory data, presenting investigation findings, and providing conclusions and recommendations. Upload the report to the GeoTracker database;
- 8) Collect a second round of six soil vapor samples six months after the first event from the semi-permanent probes per DTSC guidance and submit for chemical analysis as previously described above; and
- 9) Prepare a written report describing the second semi-annual soil vapor monitoring field activities, summarizing the laboratory data, presenting investigation findings, and providing conclusions and recommendations. Upload the report to the GeoTracker database.

IV. INVESTIGATIVE ACTIVITIES

A. Permitting

According to Alameda County Public Works Agency (ACPWA), drilling permits are not required for installation of sub-slab soil vapor probes.

B. Health and Safety Plan

AllWest will update the site specific health and safety plan prior to mobilizing to the site. A tailgate safety meeting will be given prior to commencing work. All site personnel will be required to review the health and safety plan.

C. Underground Utility Inspection and Conduit Survey

To avoid damage to underground utility installations during the course of the subsurface investigation, AllWest will contact Underground Service Alert (USA), an organization for public utility information, on the pending subsurface investigation. USA will then notify public and private entities that maintained

underground utilities within the site vicinity to locate and mark their installations for field identification. A private underground utility locator, Subtronic Corporation (Subtronic) of Concord, California, will also be employed by AllWest to conduct a magnetometer sweep investigation to locate marked and unmarked underground utilities in the vicinity of the proposed boring locations. Subtronic will also attempt to conduct a utility conduit survey of the suspected sewer line in the vicinity of the former sump and other sewer lines within the building, which may be potential conduits for contaminants. An attempt to trace the sewer line to the sump from a nearby floor drain during the previous soil vapor sampling in January 2012 was unsuccessful. Other qualified contractors may be used if necessary.

D. Sub-Slab Soil Vapor Probe Installation

A State of California C-57 licensed drilling contractor (Vironex, Inc. of Concord, California) will core through the approximately 6-inch thick concrete floor slab and approximately 1 to 4 inches into the sub-base using a power-operated coring bit or Roto-Hammer at six locations within the O'Reilly Auto Parts store. Other qualified contractors may be used if necessary. Three borings will be located within the former car wash area (current stockroom) in the vicinity of the former sump area, and the other three borings will be located within the main store area. The borings will be completed as semi-permanent sub-slab soil vapor probes. Proposed vapor probe locations are shown on Figure 4.

Pending ACEH and ACPWA approval of this method, AllWest proposes completion of the soil vapor probes using the Vapor Pin™, consisting of a hollow brass sampling device with barbed nipple fitting and outer silicone sleeve installed within the floor slab. The Vapor Pin™ is driven into a 5/8-inch diameter hole within the slab, set within a 1 1/2-inch diameter countersunk hole for flush mounting below the slab surface. No filter pack, bentonite or cement grout seal is required; since the silicone sleeve seals the probe in the borehole, only about 20 minutes of equilibrium time is required prior to sampling. A flush-mounted plastic cap covers the Vapor Pin™ and a second cap seals the barbed nipple fitting. The Vapor Pin™ standard operating procedure is included in Appendix B.

If ACEH and ACPWA approval of the Vapor Pin™ method is not forthcoming, shallow semi-permanent sub-slab soil vapor probes will be installed in each borehole per the DTSC *Final, Guidance for the Evaluation and Mitigation of Subsurface Vapor Intrusion to Indoor Air (Vapor Intrusion Guidance)*, Appendix G, October 2011. Stainless steel or plastic vapor probes, 1/2-inch diameter by 2-inch long and tipped with porous plastic membranes, will be inserted to the bottom of the boreholes. The probe tips will be attached to approximately 6-inch lengths of 0.25-inch outside diameter (OD) Teflon™ tubing extending to about 1 inch below the top of the floor slab. The top of the Teflon™ tubing in each probe is attached to a brass threaded male Swagelock™ fitting and cap recessed below the concrete floor. A fine sand filter pack approximately 4 inches thick will be

placed in the borehole annulus around the probes. Hydrated granulated bentonite will then be used to fill the annular space above the filter pack to approximately 1 inch above the bottom of the floor slab. Quick-drying cement/bentonite grout will then be used to fill the remaining annular space to the Swagelock fitting approximately ½ to ¾ inch below the top of the slab. At least 2 hours will elapse prior to collecting vapor samples to allow the bentonite and cement grout seal to hydrate and borehole conditions to equalize, per DTSC sub-slab vapor sampling guidelines (DTSC, 2011). Standard soil vapor probe installation procedures and a typical sub-slab probe construction diagram are included in Appendix C.

E. Soil Vapor Sampling

AllWest will collect soil vapor samples from the six new semi-permanent soil vapor probes following a minimum 2-hour period after hydration of the bentonite surface seals. Soil vapor sampling will be performed in general accordance with the DTSC *Advisory – Active Soil Gas Investigations*, April 2012. Soil vapor sampling procedures are included in Appendix C.

AllWest will collect one soil vapor sample from each probe in laboratory prepared 1-liter capacity SUMMA canisters. Prior to vapor purging and sample collection, a vacuum leak test of the flow-controller/gauge manifold assembly is performed for a minimum of 2 minutes. Prior to sample collection, approximately 0.5 liter of soil vapor (minimum of 3 sample system volumes) is purged at a flow rate of approximately 150-200 milliliters per minute (ml/min) from each sub-slab vapor probe using a dedicated 6-liter capacity SUMMA purge canister.

While sampling, a leak detection test is conducted using helium as a leak tracer inside an airtight plastic shroud. The helium concentration within the shroud is monitored with a helium gas detect meter to keep the concentration at approximately 20%. To verify meter accuracy, an ambient air sample is collected inside the leak detection shroud during the sampling of one probe to measure helium concentrations inside the shroud. Depending upon helium availability, other leak detection gases such as isopropyl alcohol (IPA) or difluoroethane may be substituted. A schematic diagram of the soil vapor sampling system and leak detection shroud is included in Appendix C.

Flow rates of approximately 150-200 ml/min are used to fill the sample canisters. The canisters are filled to approximate 80% of capacity (approximately 5 inches of mercury vacuum remaining). All pertinent field observations, pressure, times and readings are recorded. After filling and closing the sample valve, all SUMMA canisters are removed from the manifold, labeled with sampling information, including initial and final vacuum pressures, placed in a dark container and transported under chain-of-custody to the analytical laboratory, McCampbell Analytical, Inc., in Pittsburg, California. A copy of the soil vapor sampling field form is included in Appendix C. The semi-permanent probes will be left in place and sealed with flush-mounted plastic caps for future monitoring.

A second soil vapor monitoring event will be performed six months from the first event in order to evaluate any seasonal variability in sub-slab vapor conditions, as recommended in the *DTSC Vapor Intrusion Guidance* (DTSC, October 2011). The scope of work and sampling methodology will be similar to those described above. Laboratory analyses will be similar to those described below in Section VI.

V. QUALITY ASSURANCE / QUALITY CONTROL PROGRAM

A. Sample Preservation, Storage and Handling

All SUMMA canisters are removed from the manifold, labeled with sampling information, including initial and final vacuum pressures, and placed in a dark container for transport to the analytical laboratory

B. Chain-Of-Custody Program

All samples collected for this project will be transported under chain-of-custody protocol. The chain-of-custody program allows for the tracing of possession and handling of individual samples from the time of field collection through laboratory analysis. The document includes the signature of the collector, date and time of collection, sample number, number and type of sample containers including preservatives, SUMMA canister ID numbers, initial and final SUMMA canister vacuums, parameters requested for analysis, signatures of persons and inclusive dates involved in the chain of possession. Upon delivery to the laboratory the document will also include the name of the person receiving the samples, and date and time samples were received.

VI. ANALYTICAL METHODS

All samples selected for analysis will be analyzed by a State of California certified independent analytical laboratory. McCampbell Analytical, Inc., of Pittsburg, California, will likely perform all soil vapor and leak detection gas sample analyses. However, other qualified laboratories may be utilized dependent on work load and time frame considerations.

The soil vapor samples collected during this investigation will be analyzed for VOCs using EPA Method TO-15 (mid detection level, full scan) and helium by ASTM D1946. The ambient leak detection gas sample will be analyzed for helium by ASTM D1946. Depending upon helium availability, analyses for other leak detection gases such as isopropyl alcohol (IPA) or difluoroethane by EPA Method TO-15 may be substituted instead.

VII. REPORT PREPARATION

A written report will be prepared for this investigation after the completion of all field work and receipt of analytical results. Included in the report will be vapor probe installation details, chain-of-custody documents and copies of the analytical laboratory reports. The report will be reviewed by a California Professional Geologist. Analytical data will be compared to RWQCB soil vapor and groundwater ESLs for commercial use where site groundwater is not a potential drinking water resource to evaluate potential indoor soil vapor intrusion impact, to identify any remaining data gaps, and to evaluate low threat case closure criteria.

The report and associated documents (laboratory analytical reports, boring logs, etc.) will be uploaded to the California State Water Resources Control Board (SWRCB) GeoTracker database, and the ACHCS FTP website. A similar report will be prepared for the second semiannual soil vapor monitoring event to be performed six months after the first.

VIII. PROJECT STAFF AND SCHEDULE

Mr. Leonard P. Niles, P.G., C.H.G., a California Professional Geologist (PG 5774) and Certified Hydrogeologist (CHG 357), will provide technical oversight for this project and act as the project manager and regulatory liaison. Additionally, AllWest's staff of engineers, geologists, and technicians will be employed to perform the various tasks of the project. AllWest will inform the ACHCS at least 72 hours prior to the start of field activities. AllWest will inform the ACHCS of any significant developments during the course of the investigations. A second soil vapor monitoring event will be performed approximately six months after the first, using the previously installed semi-permanent sub-slab soil vapor probes.

IX. LIMITATIONS

AllWest has prepared this remedial investigation and corrective action plan for the exclusive use of PACCAR, Inc. (Client) for this particular project and in accordance with generally accepted practices at the time of the work and with our written proposal. No other warranties, either expressed or implied is made as to the professional advice offered. This plan is not a specification for the proposed work and should not be used to bid out any of the proposed work found within. Reliance on this plan by any party other than the Client is at the user's sole risk.

Background information that AllWest has used in preparing this report, including but not limited to previous field measurements, analytical results, site plans, and other data, has been furnished to AllWest by the Client, its previous consultants, and/or third parties.

AllWest has relied on this information as furnished. AllWest is not responsible for nor has it confirmed the accuracy of this information.

X. REFERENCES

AllWest Environmental, Inc. (AllWest), *Environmental Site Assessment, Grand Auto Store #43, 4240 East 14th Street, Oakland, California 94601*, August 10, 1995.

AllWest, *Workplan for Well Development and Sampling at Grand Auto #43, 4240 East 14th Street, Oakland*, October 29, 1999.

AllWest, *Site Closure and Groundwater Monitoring Report, Grand Auto Store #43, 4240 East 14th Street, Oakland, California*, August 15, 2000.

AllWest, *Annual Groundwater Monitoring and Well Destruction Report, Grand Auto Store #43, 4240 East 14th Street, Oakland, California*, August 27, 2001.

AllWest, *2008 Biennial Groundwater Monitoring Report, Krage Auto Supply (Former Grand Auto #43), 4240 International Boulevard (East 14th Street), Oakland, California*, July 28, 2008.

AllWest, *Soil Vapor Investigation and Groundwater Monitoring Work Plan, Krage Auto Supply (Former Grand Auto #43), 4240 International Boulevard (East 14th Street), Oakland, California 94601*, April 15, 2011.

AllWest, *Soil and Groundwater Investigation Work Plan Addendum, Krage Auto Supply (Former Grand Auto #43), 4240 International Boulevard (East 14th Street), Oakland, California 94601*, July 15, 2011.

AllWest, *2011 Groundwater Monitoring Report, O'Reilly Auto Parts (Former Grand Auto #43), 4240 International Boulevard (East 14th Street), Oakland, California*, March 16, 2012.

AllWest, *Soil Vapor and Subsurface Investigation, O'Reilly Auto Parts (Former Grand Auto #43), 4240 International Boulevard (East 14th Street), Oakland, California 94601*, March 16, 2012.

Hart Crowser, Inc. (Hart Crowser), *Sampling and Analysis Plan, Grand Auto/Super Tire Facilities, 4240/4256 East 14th Street, Oakland, California*, July 13, 1992.

Hart Crowser, *Preliminary Site Investigation Report, Grand Auto/Super Tire Facilities, 4240/4256 East 14th Street, Oakland, California 94621*, November 20, 1992.

Hart Crowser, *Supplemental Site Investigation, Grand Auto Facility, 4240 E. 14th Street, Oakland, California*, June 18, 1993.

Hart Crowser, *Quarterly Status Report, Grand Auto Facility, 4240 E. 14th Street, Oakland, California*, January 14, 1994.

Hart Crowser, *Quarterly Status Report, Grand Auto Facility, 4240 E. 14th Street, Oakland, California*, November 9, 1994.

Hart Crowser, *Facility Closure Report, Grand Auto Supply, 4240 East 14th Street, Oakland, California*, February 16, 1996.

Hart Crowser, *Risk Assessment, Grand Auto Supply, 4240 East 14th Street, Oakland, California*, October 8, 1996.

State of California Department of Toxic Substances Control (DTSC), *Final, Guidance for the Evaluation and Mitigation of Subsurface Vapor Intrusion to Indoor Air (Vapor Intrusion Guidance)*, October 2011.

DTSC, *Vapor Intrusion Mitigation Advisory Final Revision 1*, October 2011.

DTSC and State of California Regional Water Quality Control Board, Los Angeles Region (LARWQCB), *Advisory – Active Soil Gas Investigations*, April 2012.

State of California Environmental Protection Agency (Cal EPA), *Use of California Human Health Screening Levels (CHHSLs) in Evaluation of Contaminated Properties, Table 2- California Human Health Screening Levels for Indoor Air and Soil Gas*, January 2005, updated September 23, 2010.

State of California Regional Water Quality Control Board, San Francisco Bay Region (SFRWQCB), *Screening For Environmental Concerns at Sites with Contaminated Soil and Groundwater*, Interim Final November 2007, Updated March 2008.

FIGURES

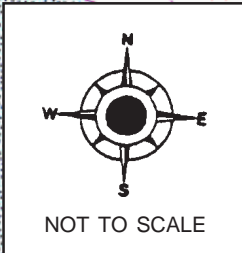
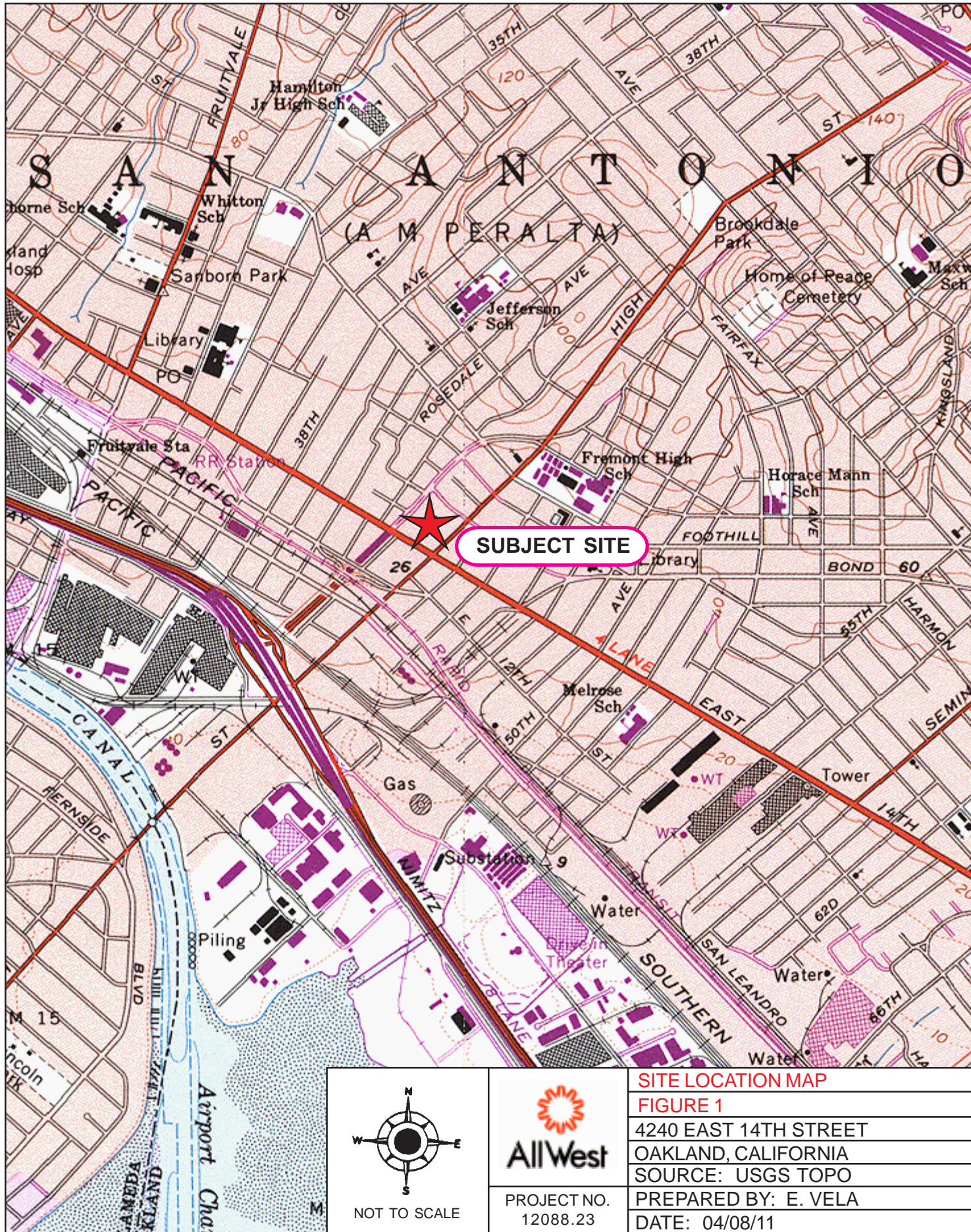





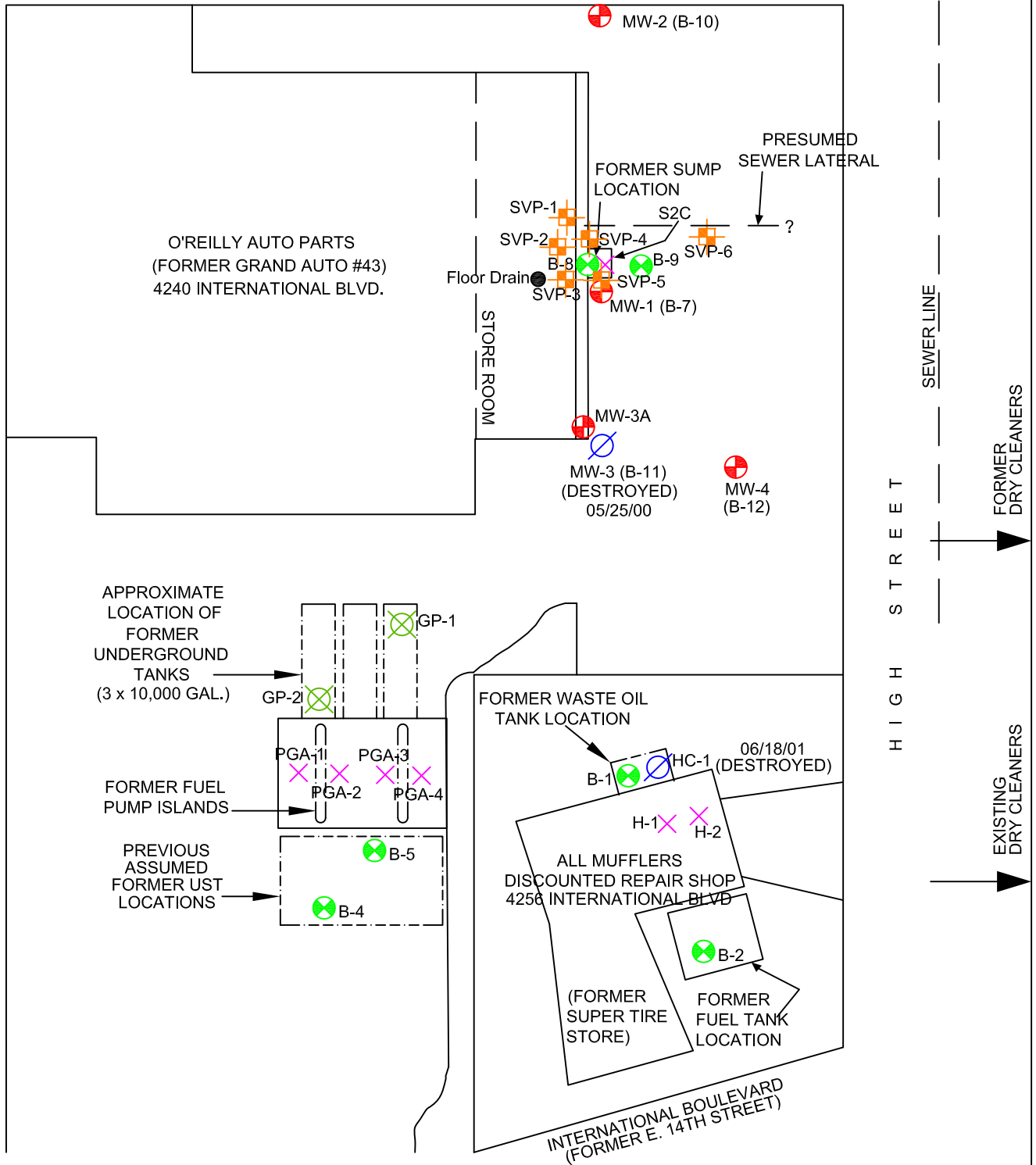

PROJECT NO.
12088.23

SITE LOCATION MAP	
FIGURE 1	
4240 EAST 14TH STREET	
OAKLAND, CALIFORNIA	
SOURCE: USGS TOPO	
PREPARED BY: E. VELA	
DATE: 04/08/11	

MISSION AUTOMOTIVE



LEGEND

- MW-2  Existing Well Location
- MW-3  Former Well Location (destroyed 2000)
- PGA-1  Trench Sample Location (HC, 1993)
- B-1  Boring Location (HC, 1992)
- GP-1  Geoprobe Boring Location (AllWest, 2012)
- SVP-1  Soil Vapor Probe Location (AllWest, 2012)

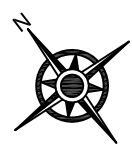

PROJECT NO.
12088.23

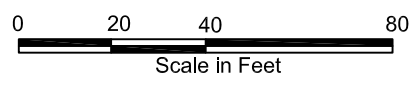

SITE PLAN WITH BORING AND WELL LOCATIONS	
FIGURE 2: O'REILLY AUTO PARTS	
4240 INTERNATIONAL BOULEVARD	
OAKLAND, CALIFORNIA	
SOURCE: ALLWEST	
PREPARED BY: C. RAMELB (02/21/12)	

MISSION AUTOMOTIVE

APPROXIMATE GROUNDWATER FLOW DIRECTION

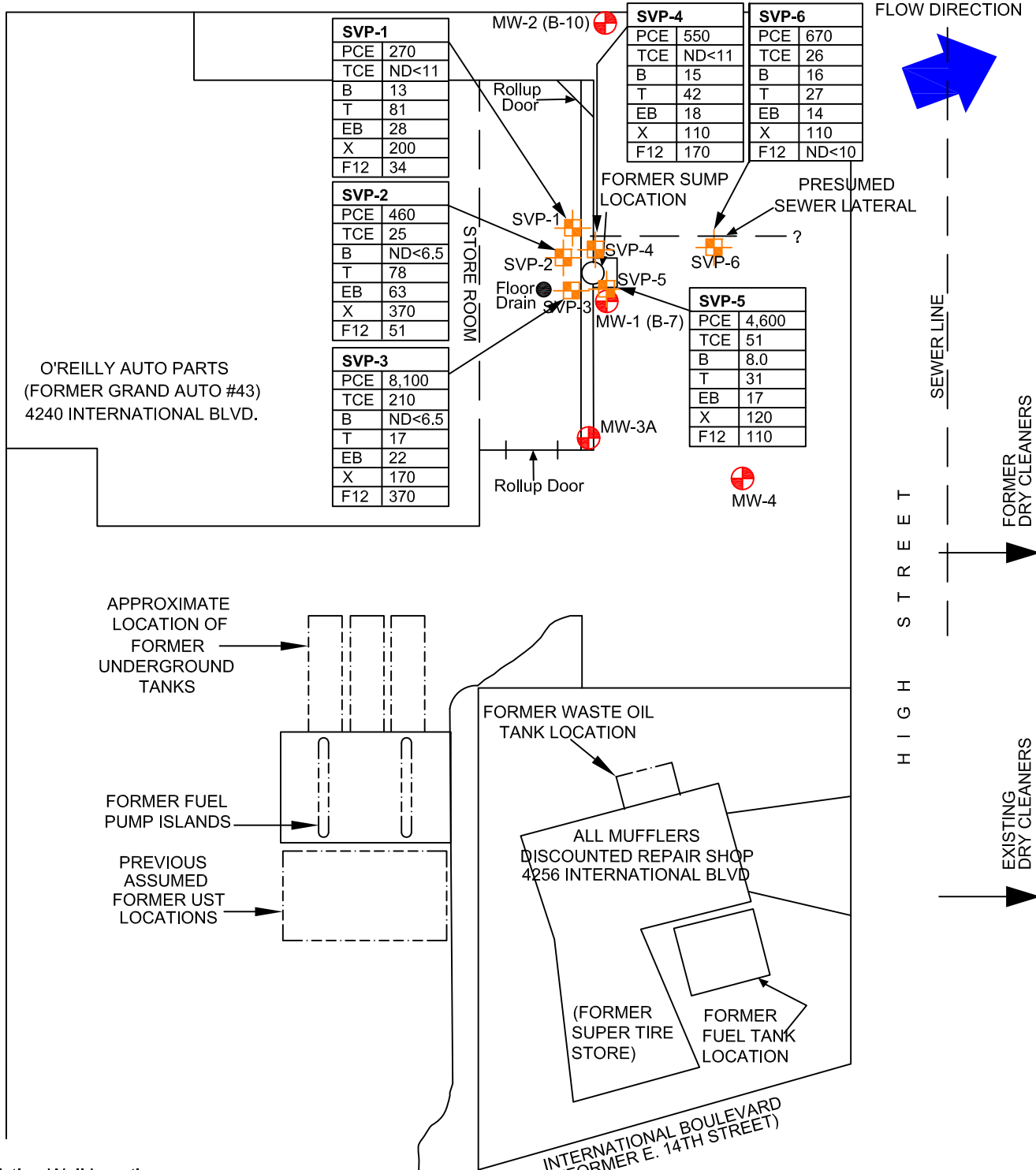

LEGEND

MW-2 Existing Well Location

SVP-1 Soil Vapor Sample Location

Concentrations in micrograms per cubic meter ($\mu\text{g}/\text{m}^3$)

- PCE = tetrachloroethene
- TCE = trichloroethene
- B = benzene
- T = toluene
- EB = ethyl benzene
- X = xylenes (total)
- F12 = Freon 12 (dichloro-difluoromethane)



PROJECT NO.
12088.23

SOIL VAPOR SAMPLE ANALYTICAL SUMMARY, 01/04/12

FIGURE 3: FORMER GRAND AUTO #43

4240 EAST 14TH STREET (INTERNATIONAL BOULEVARD)

OAKLAND, CALIFORNIA

SOURCE: ALLWEST

PREPARED BY: C. RAMELB (02/21/12)

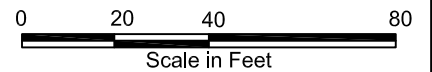

MISSION AUTOMOTIVE

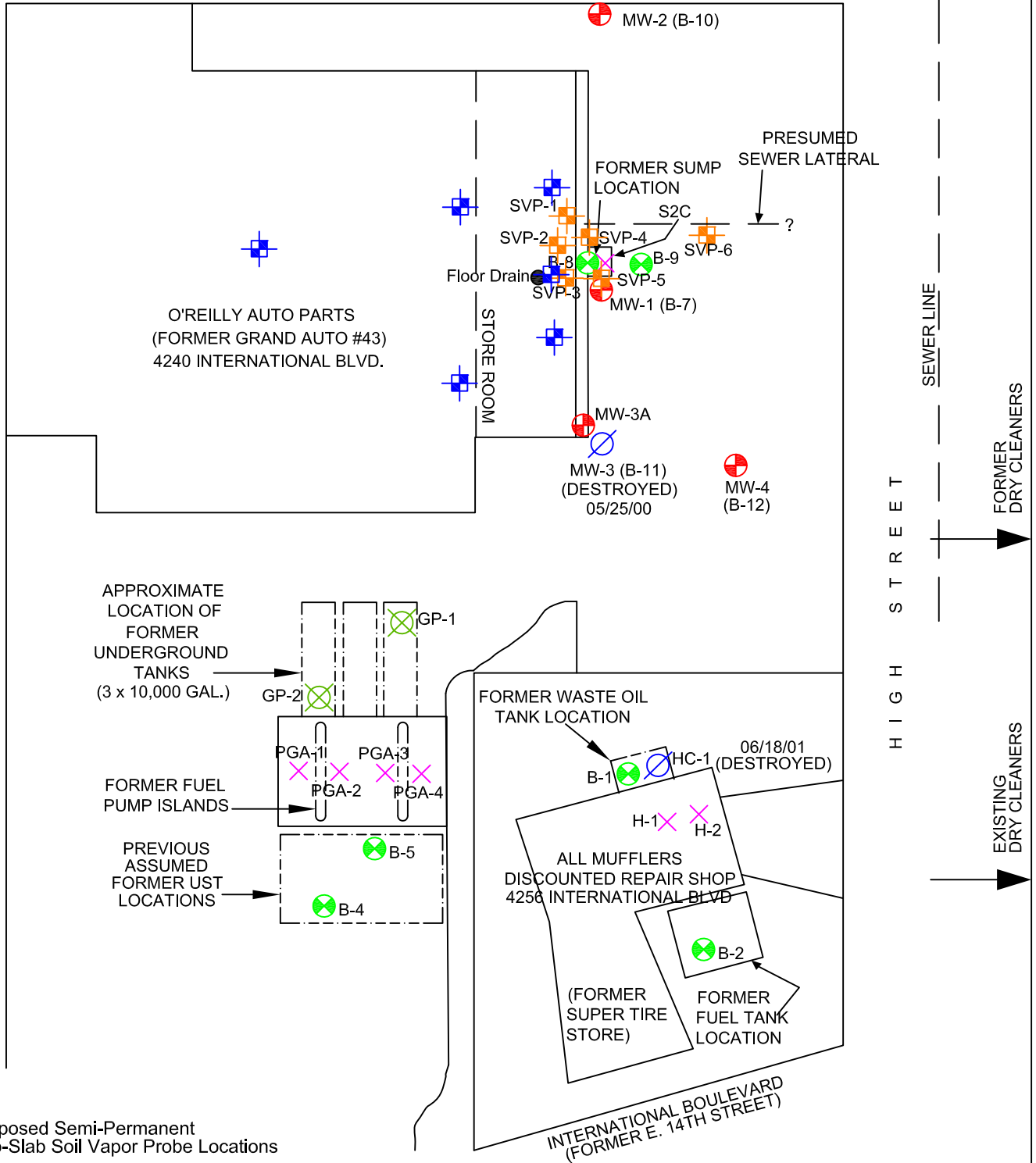

LEGEND

- Proposed Semi-Permanent Sub-Slab Soil Vapor Probe Locations
- MW-2 Existing Well Location
- MW-3 Former Well Location (destroyed 2000)
- PGA-1 Trench Sample Location (HC, 1993)
- B-1 Boring Location (HC, 1992)
- GP-1 Geoprobe Boring Location (AllWest, 2012)
- SVP-1 Soil Vapor Probe Location (AllWest, 2012)

		PROPOSED SOIL VAPOR PROBE LOCATIONS
		FIGURE 4: O'REILLY AUTO PARTS
PROJECT NO. 12088.23		SOURCE: ALLWEST
		PREPARED BY: C. RAMELB (rev. 07/17/12)

Appendix A



ENVIRONMENTAL HEALTH SERVICES
ENVIRONMENTAL PROTECTION
1131 Harbor Bay Parkway, Suite 250
Alameda, CA 94502-6577
(510) 567-6700
FAX (510) 337-9335

June 5, 2012

Ms. Vicki ZumBrunnen (*Sent via E-mail to: Vicki.ZumBrunnen@PACCAR.com*)
PACCAR, Inc.
Corporate Environmental Department
P.O. Box 1518
Bellevue, WA 98009

Hess Properties LLC
c/o Mr. Joseph Hess
2709 Park Avenue
La Verne, CA 91750

Transamerica Title Insurance Company
c/o CSK Auto, Inc.
645 E Missouri Avenue
Phoenix, AZ 85012

Subject: Site Investigation Results for SLIC Case No. RO0002483 and GeoTracker Global ID T06019705075, Grand Auto, 4240 International Boulevard, Oakland, CA 94601

Dear Ms. ZumBrunnen, Mr. Hess, and Transamerica Title Insurance Company:

Alameda County Environmental Health (ACEH) staff has reviewed the Spills, Leaks, Investigations, and Cleanup (SLIC) case file for the subject site including the recently submitted documents entitled, "*Soil Vapor and Subsurface Investigation*," dated March 16, 2012 (Site Investigation Report) and "*2011 Groundwater Monitoring Report*," also dated March 16, 2012 (Monitoring Report). The Site Investigation Report, which was prepared by AllWest Environmental, presents results from soil, soil vapor, and groundwater sampling conducted in two areas of the site.

Tetrachloroethene (PCE) was detected in each of the five soil vapor samples collected in the area of a former sump at concentrations up to 8,100 micrograms per cubic meter ($\mu\text{g}/\text{m}^3$). The maximum concentration of PCE in soil vapor was detected in soil vapor sample SVP-3, which was collected beneath the interior of the building. We request that you submit a Work Plan that addressed the technical comments below.

TECHNICAL COMMENTS

- 1. Soil Vapor Results within the Building.** PCE was detected in each of the three soil vapor samples collected beneath the interior floor of the building. The maximum reported concentration of 8,100 $\mu\text{g}/\text{m}^3$ of PCE exceeds the commercial land use California Human Health Screening Level (CHHSL) for PCE in soil vapor of 603 $\mu\text{g}/\text{m}^3$ by more than an order of magnitude. Although the detection of PCE in soil vapor at concentrations exceeding the CHHSL does not necessarily indicate that adverse impacts to human health are occurring, it does indicate that further assessment is required. Consistent with the approach used in the, California Department of Toxic Substances Control (DTSC) "*Guidance for the Evaluation and Mitigation of Subsurface Vapor Intrusion to Indoor Air*," dated December 15, 2004, a step-wise investigation approach is recommended to evaluate potential vapor intrusion. Since soil vapor results indicate a potential for vapor intrusion to indoor air, sub-slab sampling appears to be necessary for the next step. Therefore, we request that you submit a Work Plan to conduct sub-slab vapor sampling beneath the floor of the building adjacent to the sump area.

2. **Conclusion Regarding Potential for Soil Vapor Intrusion.** The Investigation Report presents a conclusion that vapor intrusion into the building is probably not a significant exposure pathway to building occupants since only one of three soil vapor samples collection from the building interior exceeded the CHHSL. The existing data do not necessarily support this conclusion. DTSC guidance states, "Use the maximum soil gas concentration over an area of the footprint of existing or assumed future buildings to compensate for potentially isolated rooms within a building and the uncertainties in soil gas collection," (page 2-5 of "*Use of California Human Health Screening Levels (CHHSLs) in Evaluation of Contaminated Properties*, DTSC January 2005). As noted in technical comment 1, sub-slab sampling is required to evaluate the potential for vapor intrusion.
3. **Investigation Results for Former UST Area.** Two soil borings were advanced to collect soil and grab groundwater samples from the former UST area. Petroleum hydrocarbons were not detected at concentrations above screening levels in soil and groundwater samples from the two borings. Based on these results and results from the groundwater monitoring, no further investigation is necessary in the area of the former USTs.

TECHNICAL REPORT REQUEST

Please submit technical reports to Alameda County Environmental Health (Attention: Jerry Wickham), according to the following schedule:

- **August 7, 2012** – Work Plan for Sub-slab Vapor Sampling

If you have any questions, please call me at (510) 567-6791 or send me an electronic mail message at jerry.wickham@acgov.org. Online case files are available for review at the following website: <http://www.acgov.org/aceh/index.htm>.

Sincerely,



Digitally signed by Jerry Wickham
DN: cn=Jerry Wickham, o=Environmental Health, ou=Alameda
County, email=jerry.wickham@acgov.org, c=US
Date: 2012.06.05 16:37:22 -07'00'

Jerry Wickham, California PG 3766, CEG 1177, and CHG 297
Senior Hazardous Materials Specialist

Attachment: Responsible Party(ies) Legal Requirements/Obligations

Enclosure: ACEH Electronic Report Upload (ftp) Instructions

cc: Leroy Griffin, Oakland Fire Department, 250 Frank H. Ogawa Plaza, Ste. 3341, Oakland, CA 94612-2032 (Sent via E-mail to: lgriffin@oaklandnet.com)

Responsible Parties
RO0002483
June 5, 2012
Page 3

Leonard Niles, AllWest Environmental, Inc., 530 Howard Street, Suite 300, San Francisco, CA
94105 (*Sent via E-mail to: lniles@allwest1.com*)

Donna Drogos, ACEH (*Sent via E-mail to: donna.drogos@acgov.org*)
Jerry Wickham, ACEH (*Sent via E-mail to: jerry.wickham@acgov.org*)

GeoTracker, eFile

Attachment 1

Responsible Party(ies) Legal Requirements / Obligations

REPORT REQUESTS

These reports are being requested pursuant to California Health and Safety Code Section 25296.10. 23 CCR Sections 2652 through 2654, and 2721 through 2728 outline the responsibilities of a responsible party in response to an unauthorized release from a petroleum UST system, and require your compliance with this request.

ELECTRONIC SUBMITTAL OF REPORTS

ACEH's Environmental Cleanup Oversight Programs (LOP and SLIC) require submission of reports in electronic form. The electronic copy replaces paper copies and is expected to be used for all public information requests, regulatory review, and compliance/enforcement activities. Instructions for submission of electronic documents to the Alameda County Environmental Cleanup Oversight Program FTP site are provided on the attached "Electronic Report Upload Instructions." Submission of reports to the Alameda County FTP site is an addition to existing requirements for electronic submittal of information to the State Water Resources Control Board (SWRCB) GeoTracker website. In September 2004, the SWRCB adopted regulations that require electronic submittal of information for all groundwater cleanup programs. For several years, responsible parties for cleanup of leaks from underground storage tanks (USTs) have been required to submit groundwater analytical data, surveyed locations of monitoring wells, and other data to the GeoTracker database over the Internet. Beginning July 1, 2005, these same reporting requirements were added to Spills, Leaks, Investigations, and Cleanup (SLIC) sites. Beginning July 1, 2005, electronic submittal of a complete copy of all reports for all sites is required in GeoTracker (in PDF format). Please visit the SWRCB website for more information on these requirements (http://www.waterboards.ca.gov/water_issues/programs/ust/electronic_submittal/).

PERJURY STATEMENT

All work plans, technical reports, or technical documents submitted to ACEH must be accompanied by a cover letter from the responsible party that states, at a minimum, the following: "I declare, under penalty of perjury, that the information and/or recommendations contained in the attached document or report is true and correct to the best of my knowledge." This letter must be signed by an officer or legally authorized representative of your company. Please include a cover letter satisfying these requirements with all future reports and technical documents submitted for this fuel leak case.

PROFESSIONAL CERTIFICATION & CONCLUSIONS/RECOMMENDATIONS

The California Business and Professions Code (Sections 6735, 6835, and 7835.1) requires that work plans and technical or implementation reports containing geologic or engineering evaluations and/or judgments be performed under the direction of an appropriately registered or certified professional. For your submittal to be considered a valid technical report, you are to present site specific data, data interpretations, and recommendations prepared by an appropriately licensed professional and include the professional registration stamp, signature, and statement of professional certification. Please ensure all that all technical reports submitted for this fuel leak case meet this requirement.

UNDERGROUND STORAGE TANK CLEANUP FUND

Please note that delays in investigation, later reports, or enforcement actions may result in your becoming ineligible to receive grant money from the state's Underground Storage Tank Cleanup Fund (Senate Bill 2004) to reimburse you for the cost of cleanup.

AGENCY OVERSIGHT

If it appears as though significant delays are occurring or reports are not submitted as requested, we will consider referring your case to the Regional Board or other appropriate agency, including the County District Attorney, for possible enforcement actions. California Health and Safety Code, Section 25299.76 authorizes enforcement including administrative action or monetary penalties of up to \$10,000 per day for each day of violation.

Alameda County Environmental Cleanup Oversight Programs (LOP and SLIC)	REVISION DATE: July 20, 2010
	ISSUE DATE: July 5, 2005
	PREVIOUS REVISIONS: October 31, 2005; December 16, 2005; March 27, 2009; July 8, 2010
SECTION: Miscellaneous Administrative Topics & Procedures	SUBJECT: Electronic Report Upload (ftp) Instructions

The Alameda County Environmental Cleanup Oversight Programs (LOP and SLIC) require submission of all reports in electronic form to the county's ftp site. Paper copies of reports will no longer be accepted. The electronic copy replaces the paper copy and will be used for all public information requests, regulatory review, and compliance/enforcement activities.

REQUIREMENTS

- **Please do not submit reports as attachments to electronic mail.**
- Entire report including cover letter must be submitted to the ftp site as a **single portable document format (PDF) with no password protection.**
- It is **preferable** that reports be converted to PDF format from their original format, (e.g., Microsoft Word) rather than scanned.
- **Signature pages and perjury statements must be included and have either original or electronic signature.**
- **Do not password protect the document.** Once indexed and inserted into the correct electronic case file, the document will be secured in compliance with the County's current security standards and a password. **Documents with password protection will not be accepted.**
- Each page in the PDF document should be rotated in the direction that will make it easiest to read on a computer monitor.
- Reports must be named and saved using the following naming convention:

RO#_Report Name_Year-Month-Date (e.g., RO#5555_WorkPlan_2005-06-14)

Submission Instructions

- 1) Obtain User Name and Password
 - a) Contact the Alameda County Environmental Health Department to obtain a User Name and Password to upload files to the ftp site.
 - i) Send an e-mail to deh.loptoxic@acgov.org
 - b) In the subject line of your request, be sure to include "**ftp PASSWORD REQUEST**" and in the body of your request, include the **Contact Information, Site Addresses, and the Case Numbers (RO# available in Geotracker) you will be posting for.**
- 2) Upload Files to the ftp Site
 - a) Using Internet Explorer (IE4+), go to <ftp://alcoftp1.acgov.org>
 - (i) Note: Netscape, Safari, and Firefox browsers will not open the FTP site as they are NOT being supported at this time.
 - b) Click on Page located on the Command bar on upper right side of window, and then scroll down to Open FTP Site in Windows Explorer.
 - c) Enter your User Name and Password. (Note: Both are Case Sensitive.)
 - d) Open "My Computer" on your computer and navigate to the file(s) you wish to upload to the ftp site.
 - e) With both "My Computer" and the ftp site open in separate windows, drag and drop the file(s) from "My Computer" to the ftp window.
- 3) Send E-mail Notifications to the Environmental Cleanup Oversight Programs
 - a) Send email to deh.loptoxic@acgov.org notify us that you have placed a report on our ftp site.
 - b) Copy your Caseworker on the e-mail. Your Caseworker's e-mail address is the entire first name then a period and entire last name @acgov.org. (e.g., firstname.lastname@acgov.org)
 - c) The subject line of the e-mail must start with the RO# followed by **Report Upload**. (e.g., Subject: RO1234 Report Upload) If site is a new case without an RO#, use the street address instead.
 - d) If your document meets the above requirements and you follow the submission instructions, you will receive a notification by email indicating that your document was successfully uploaded to the ftp site.

Appendix B



STANDARD GEOPROBE® AND SUB-SLAB PROBE SOIL VAPOR SAMPLING PROCEDURES

Geoprobe® PRT Soil Vapor Probe Advancement Sampling

The Geoprobe® Post Run Tubing (PRT) soil vapor sampling process involves driving into the subsurface a disposable Geoprobe® sampling probe with expendable tip and a PRT adapter that are connected to 4-foot sections of Geoprobe® 1.25-inch inside diameter (ID) extension rods. The PRT adapter has a reverse-thread adapter at the upper end to allow the connection of flexible soil vapor sampling tubing with a PRT tubing adaptor after the installation (post-run) of the tip. The entire sampling assembly, the sampling tip, PRT adapter, and the Geoprobe® extension rods, is driven into the subsurface by a truck-mounted hydraulic percussion hammer. The sampler is driven to the desired depth as additional rods are connected. At the desired sampling depth, a sufficient length of disposable flexible polyethylene or Teflon® sample tubing is first lowered through the center of the extension rod and connected to the PRT adapter. The extension rod is then retracted 3 to 4 inches to create a small void around the PRT adapter and the expendable sampling tip for extracting a soil vapor sample from that location. Bentonite chips will be used to fill the annular space between the probe and the subgrade material to the ground surface. The bentonite will then be hydrated with distilled water. The temporary Geoprobe® PRT soil vapor probe will be sampled at least 30 minutes following driving of the probe, to allow vapor conditions to equalize in subsurface materials and the bentonite surface seal to hydrate.

Sub Slab Soil Vapor Probe Installation

Semi-permanent sub-slab soil vapor probes are emplaced as follows: A 1-inch diameter hole is drilled through the concrete floor slab using a portable electric drill. The boreholes are advanced approximately 0.5 feet bgs into the subgrade material beneath the floor slab. Stainless steel vapor probes 2 inches long by 0.5 inches in diameter, tipped with porous plastic membranes, will be inserted to the bottom of each sub-slab borehole. The probe tips will be attached to lengths of 0.25-inch diameter Teflon® tubing extending to the top of the floor slab. A fine sand filter pack will be placed in the borehole annulus around the probe. Bentonite chips will then used to fill the borehole annular space above the filter pack between the probe and the to the floor slab base. The bentonite will then be hydrated with distilled water.

Portland cement will be poured into the borehole annulus in the concrete floor slab to seal the probe. Care will be taken not to over hydrate the bentonite and cement to limit the introduction of excess moisture to the subsurface. Each probe will be constructed with a brass threaded fitting and cap attached to the top of the Teflon® tubing and recessed below the concrete floor. A plastic cap will then be placed flush with the concrete floor to minimize tripping hazards. AllWest will allow a minimum of two days prior to sampling to allow the cement to setup and for subsurface conditions to stabilize.

Soil vapor sampling procedures will be similar for both the semi-permanent and temporary vapor probes, in general accordance with *Interim Final, Guidance for the Evaluation and Mitigation of Subsurface Vapor Intrusion to Indoor Air - DTSC December 15, 2004 (Revised February 7, 2005)*. Soil vapor sampling will not be performed if measurable precipitation has occurred within the previous five days.

Soil Vapor Sampling via Syringe and Mobile Laboratory

The surface end of the flexible tubing is first connected to a vacuum tank with a diaphragm pump to purge the ambient air from the tubing. After a minimum of one minute purging time to remove at least 3



sampling system volumes, the flexible tubing is connected to a syringe collect a vapor sample. The syringe is then immediately transported to an on-site mobile laboratory for analysis.

Soil Vapor Sampling via Summa Canister

AllWest will collect soil vapor samples in laboratory prepared 6-liter capacity SUMMA canisters. Prior to vapor purging and sample collection, a vacuum leak test of the flow-controller/gauge manifold assembly will be performed for a minimum of 5 minutes. Prior to sample collection, approximately 1 liter of soil vapor (or a minimum of 3 sampling system volumes) will be purged at a flow rate of approximately 200 milliliters per minute (ml/min) from each sub-slab vapor probe using a dedicated 6-liter capacity SUMMA purge canister.

During vapor sample collection, a vacuum leak test of the flow-controller/gauge manifold assembly will be performed using isopropyl alcohol (IPA), difluoroethane or helium as a leak tracer inside an airtight shroud. IPA concentrations inside the shroud will be monitored using a photo-ionization detector (PID). An ambient air sample will be collected using a SUMMA canister inside the leak detection shroud during at least one soil vapor probe sampling to measure IPA, difluoroethane or helium concentrations inside the shroud concurrent with PID readings and soil vapor sample analysis. Flow rates of approximately 200 milliliters per minute (ml/min) will be used to fill the canisters. The canisters will be filled to approximately 80% of capacity. All pertinent field observations, pressure, times and readings will be recorded. Sample containers will be labeled, placed in a dark container and transported under chain-of-custody control to the analytical laboratory.

Scope:

This standard operating procedure describes the installation and extraction of the Vapor Pin™¹ for use in sub-slab soil-gas sampling.

Purpose:

The purpose of this procedure is to assure good quality control in field operations and uniformity between field personnel in the use of the Vapor Pin™ for the collection of sub-slab soil-gas samples.

Equipment Needed:

- Assembled Vapor Pin™ [Vapor Pin™ and silicone sleeve (Figure 1)];
- Hammer drill;
- 5/8-inch diameter hammer bit (Hilti™ TE-YX 5/8" x 22" #00206514 or equivalent);
- 1½-inch diameter hammer bit (Hilti™ TE-YX 1½" x 23" #00293032 or equivalent) for flush mount applications;
- ¾-inch diameter bottle brush;
- Wet/dry vacuum with HEPA filter (optional);
- Vapor Pin™ installation/extraction tool;
- Dead blow hammer;
- Vapor Pin™ flush mount cover, as necessary;
- Vapor Pin™ protective cap; and
- VOC-free hole patching material (hydraulic cement) and putty knife or trowel.



Figure 1. Assembled Vapor Pin™.

Installation Procedure:

- 1) Check for buried obstacles (pipes, electrical lines, etc.) prior to proceeding.
- 2) Set up wet/dry vacuum to collect drill cuttings.
- 3) If a flush mount installation is required, drill a 1½-inch diameter hole at least 1¾-inches into the slab.
- 4) Drill a 5/8-inch diameter hole through the slab and approximately 1-inch into the underlying soil to form a void.
- 5) Remove the drill bit, brush the hole with the bottle brush, and remove the loose cuttings with the vacuum.
- 6) Place the lower end of Vapor Pin™ assembly into the drilled hole. Place the small hole located in the handle of the extraction/installation tool over the Vapor Pin™ to protect the barb fitting and cap, and tap the Vapor Pin™ into place using a

¹Cox-Colvin & Associates, Inc., designed and developed the Vapor Pin™; a patent is pending.

dead blow hammer (Figure 2). Make sure the extraction/installation tool is aligned parallel to the Vapor Pin™ to avoid damaging the barb fitting.



Figure 2. Installing the Vapor Pin™.

For flush mount installations, unscrew the threaded coupling from the installation/extraction handle and use the hole in the end of the tool to assist with the installation (Figure 3).



Figure 3. Flush-mount installation.

During installation, the silicone sleeve will form a slight bulge between the slab and the Vapor Pin™ shoulder. Place the protective cap on Vapor Pin™ to prevent vapor loss prior to sampling (Figure 4).



Figure 4. Installed Vapor Pin™.

- 7) For flush mount installations, cover the Vapor Pin™ with a flush mount cover.
- 8) Allow 20 minutes or more (consult applicable guidance for your situation) for the sub-slab soil-gas conditions to equilibrate prior to sampling.
- 9) Remove protective cap and connect sample tubing to the barb fitting of the Vapor Pin™ (Figure 5).

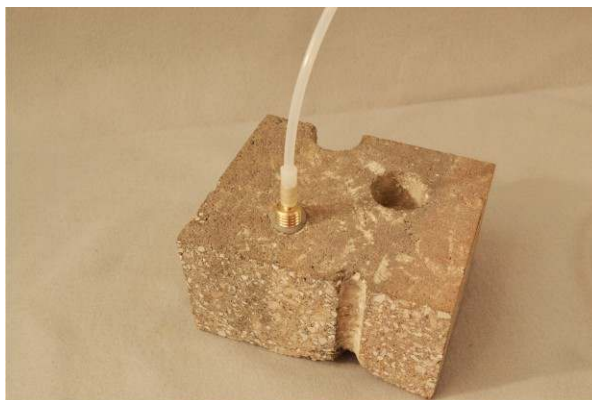

Figure 5. Vapor Pin™ sample connection.

- 10) Conduct leak tests [(e.g., real-time monitoring of oxygen levels on extracted sub-slab soil gas, or placement of a water

dam around the Vapor Pin™) Figure 6]. Consult your local guidance for possible tests.



Figure 6. Water dam used for leak detection.

11) Collect sub-slab soil gas sample. When finished sampling, replace the protective cap and flush mount cover until the next sampling event. If the sampling is complete, extract the Vapor Pin™.

Extraction Procedure:

1) Remove the protective cap, and thread the installation/extraction tool onto the barrel of the Vapor Pin™ (Figure 7). Continue



Figure 7. Removing the Vapor Pin™.

turning the tool to assist in extraction, then pull the Vapor Pin™ from the hole (Figure 8).



Figure 8. Extracted Vapor Pin™.

- 2) Fill the void with hydraulic cement and smooth with the trowel or putty knife.
- 3) Prior to reuse, remove the silicone sleeve and discard. Decontaminate the Vapor Pin™ in a hot water and Alconox® wash, then heat in an oven to a temperature of 130° C.

The Vapor Pin™ is designed to be used repeatedly; however, replacement parts and supplies will be required periodically. These parts are available on-line at www.CoxColvin.com.

Replacement Parts:

- Vapor Pin™ Kit Case - VPC001
- Vapor Pins™ - VPIN0522
- Silicone Sleeves - VPTS077
- Installation/Extraction Tool - VP1E023
- Protective Caps - VPPC010
- Flush Mount Covers - VPFM050
- Water Dam - VPWD004
- Brush - VPB026

General Schematic of Sub-Slab Vapor Probe

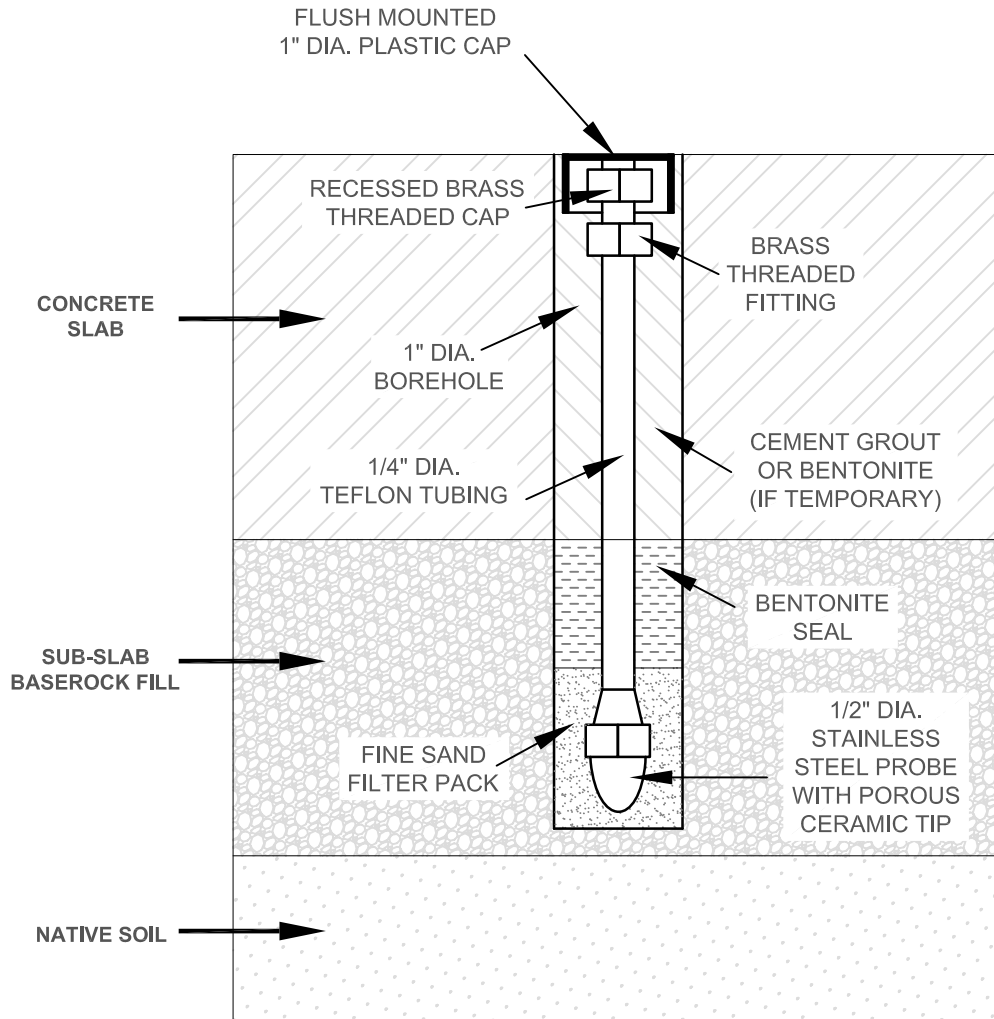

NOT TO SCALE



AllWest

STANDARD OPERATING PROCEDURE

SOIL VAPOR SAMPLING

SUB-SLAB PROBE

SOURCE: ALLWEST

PREPARED BY: C. RAMELB

General Soil Gas Sampling Manifold Schematic with Leak Detection Shroud

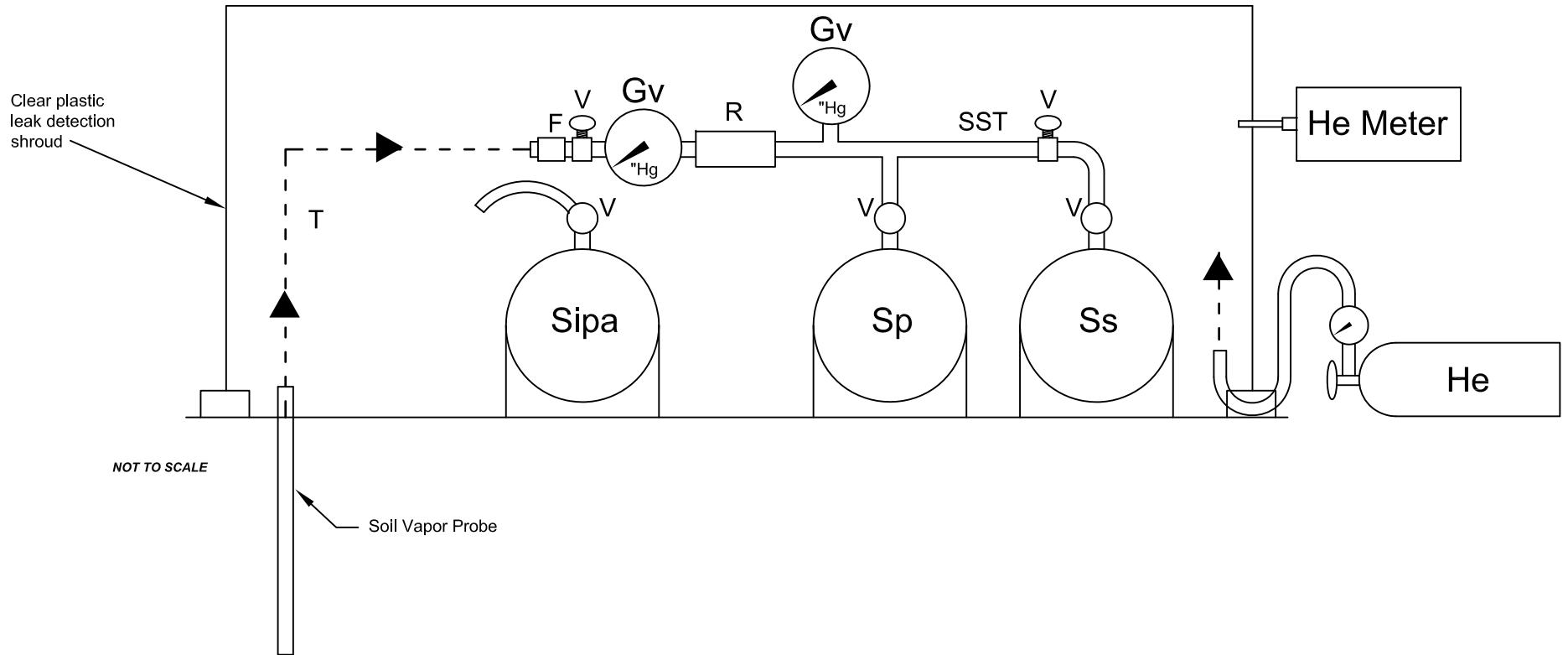

LEGEND

F	=	Filter
V	=	Valve
Gp	=	Pressure Gauge
R	=	Flow Regulator
Gv	=	Vacuum Gauge
Sp	=	Purge Summa Canister
Ss	=	Sample Summa Canister
Sipa	=	Ambient Air Helium Leak Detect Gas Summa Canister
He Meter	=	Helium detector for He concentration readings
T	=	Disposable Teflon or Polyethylene Tubing
SST	=	Stainless Steel Tubing and Fittings
He	=	Helium tank, leak detect gas, regulator and tubing



STANDARD OPERATING PROCEDURE
SOIL VAPOR SAMPLING
HELIUM SHROUD
SOURCE: ALLWEST
PREPARED BY: C. RAMELB

Appendix C



STANDARD GEOPROBE® AND SUB-SLAB PROBE SOIL VAPOR SAMPLING PROCEDURES

Geoprobe® PRT Soil Vapor Probe Advancement Sampling

The Geoprobe® Post Run Tubing (PRT) soil vapor sampling process involves driving into the subsurface a disposable Geoprobe® sampling probe with expendable tip and a PRT adapter that are connected to 4-foot sections of Geoprobe® 1.25-inch inside diameter (ID) extension rods. The PRT adapter has a reverse-thread adapter at the upper end to allow the connection of flexible soil vapor sampling tubing with a PRT tubing adaptor after the installation (post-run) of the tip. The entire sampling assembly, the sampling tip, PRT adapter, and the Geoprobe® extension rods, is driven into the subsurface by a truck-mounted hydraulic percussion hammer. The sampler is driven to the desired depth as additional rods are connected. At the desired sampling depth, a sufficient length of disposable flexible polyethylene or Teflon® sample tubing is first lowered through the center of the extension rod and connected to the PRT adapter. The extension rod is then retracted 3 to 4 inches to create a small void around the PRT adapter and the expendable sampling tip for extracting a soil vapor sample from that location. Bentonite chips will be used to fill the annular space between the probe and the subgrade material to the ground surface. The bentonite will then be hydrated with distilled water. The temporary Geoprobe® PRT soil vapor probe will be sampled at least 30 minutes following driving of the probe, to allow vapor conditions to equalize in subsurface materials and the bentonite surface seal to hydrate.

Sub Slab Soil Vapor Probe Installation

Semi-permanent sub-slab soil vapor probes are emplaced as follows: A 1-inch diameter hole is drilled through the concrete floor slab using a portable electric drill. The boreholes are advanced approximately 0.5 feet bgs into the subgrade material beneath the floor slab. Stainless steel vapor probes 2 inches long by 0.5 inches in diameter, tipped with porous plastic membranes, will be inserted to the bottom of each sub-slab borehole. The probe tips will be attached to lengths of 0.25-inch diameter Teflon® tubing extending to the top of the floor slab. A fine sand filter pack will be placed in the borehole annulus around the probe. Bentonite chips will then used to fill the borehole annular space above the filter pack between the probe and the to the floor slab base. The bentonite will then be hydrated with distilled water.

Portland cement will be poured into the borehole annulus in the concrete floor slab to seal the probe. Care will be taken not to over hydrate the bentonite and cement to limit the introduction of excess moisture to the subsurface. Each probe will be constructed with a brass threaded fitting and cap attached to the top of the Teflon® tubing and recessed below the concrete floor. A plastic cap will then be placed flush with the concrete floor to minimize tripping hazards. AllWest will allow a minimum of two days prior to sampling to allow the cement to setup and for subsurface conditions to stabilize.

Soil vapor sampling procedures will be similar for both the semi-permanent and temporary vapor probes, in general accordance with *Interim Final, Guidance for the Evaluation and Mitigation of Subsurface Vapor Intrusion to Indoor Air - DTSC December 15, 2004 (Revised February 7, 2005)*. Soil vapor sampling will not be performed if measurable precipitation has occurred within the previous five days.

Soil Vapor Sampling via Syringe and Mobile Laboratory

The surface end of the flexible tubing is first connected to a vacuum tank with a diaphragm pump to purge the ambient air from the tubing. After a minimum of one minute purging time to remove at least 3



sampling system volumes, the flexible tubing is connected to a syringe collect a vapor sample. The syringe is then immediately transported to an on-site mobile laboratory for analysis.

Soil Vapor Sampling via Summa Canister

AllWest will collect soil vapor samples in laboratory prepared 6-liter capacity SUMMA canisters. Prior to vapor purging and sample collection, a vacuum leak test of the flow-controller/gauge manifold assembly will be performed for a minimum of 5 minutes. Prior to sample collection, approximately 1 liter of soil vapor (or a minimum of 3 sampling system volumes) will be purged at a flow rate of approximately 200 milliliters per minute (ml/min) from each sub-slab vapor probe using a dedicated 6-liter capacity SUMMA purge canister.

During vapor sample collection, a vacuum leak test of the flow-controller/gauge manifold assembly will be performed using isopropyl alcohol (IPA), difluoroethane or helium as a leak tracer inside an airtight shroud. IPA concentrations inside the shroud will be monitored using a photo-ionization detector (PID). An ambient air sample will be collected using a SUMMA canister inside the leak detection shroud during at least one soil vapor probe sampling to measure IPA, difluoroethane or helium concentrations inside the shroud concurrent with PID readings and soil vapor sample analysis. Flow rates of approximately 200 milliliters per minute (ml/min) will be used to fill the canisters. The canisters will be filled to approximately 80% of capacity. All pertinent field observations, pressure, times and readings will be recorded. Sample containers will be labeled, placed in a dark container and transported under chain-of-custody control to the analytical laboratory.

General Schematic of Sub-Slab Vapor Probe

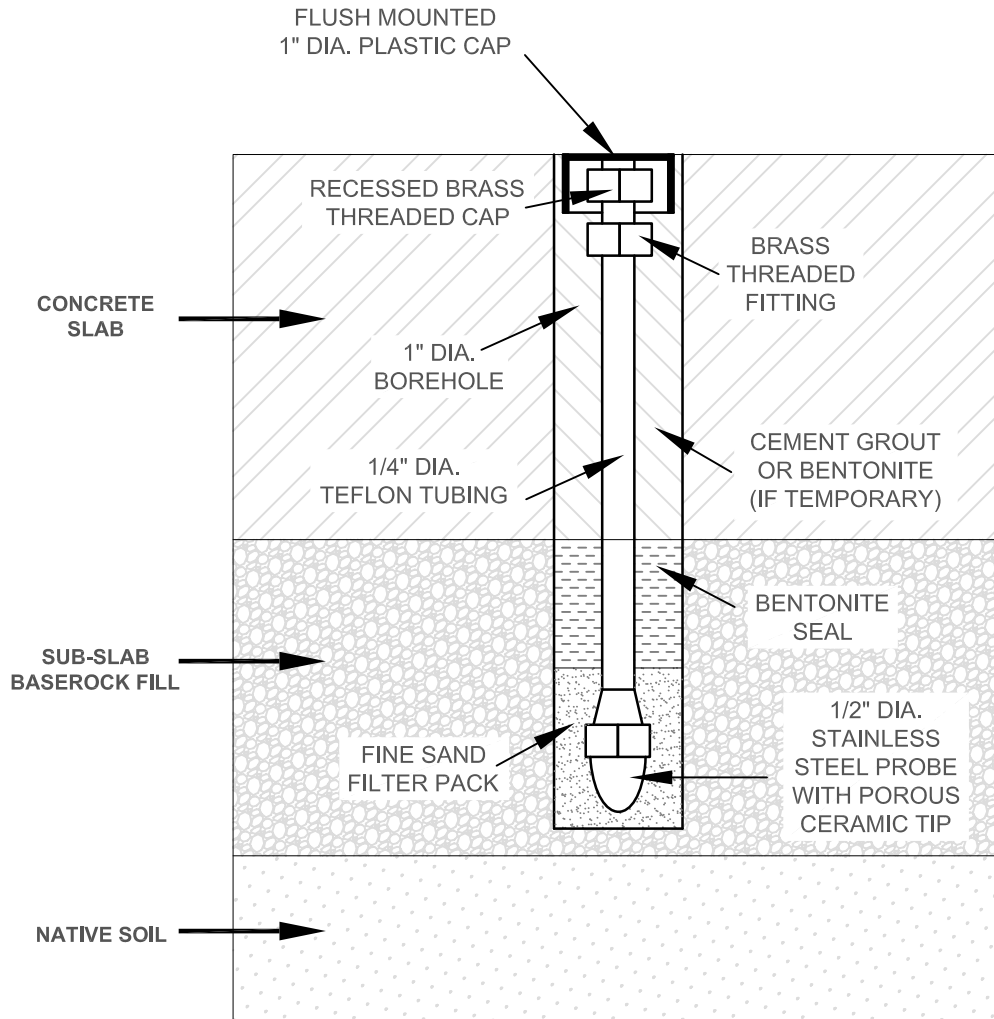

NOT TO SCALE



AllWest

STANDARD OPERATING PROCEDURE

SOIL VAPOR SAMPLING

SUB-SLAB PROBE

SOURCE: ALLWEST

PREPARED BY: C. RAMELB

General Soil Gas Sampling Manifold Schematic with Leak Detection Shroud

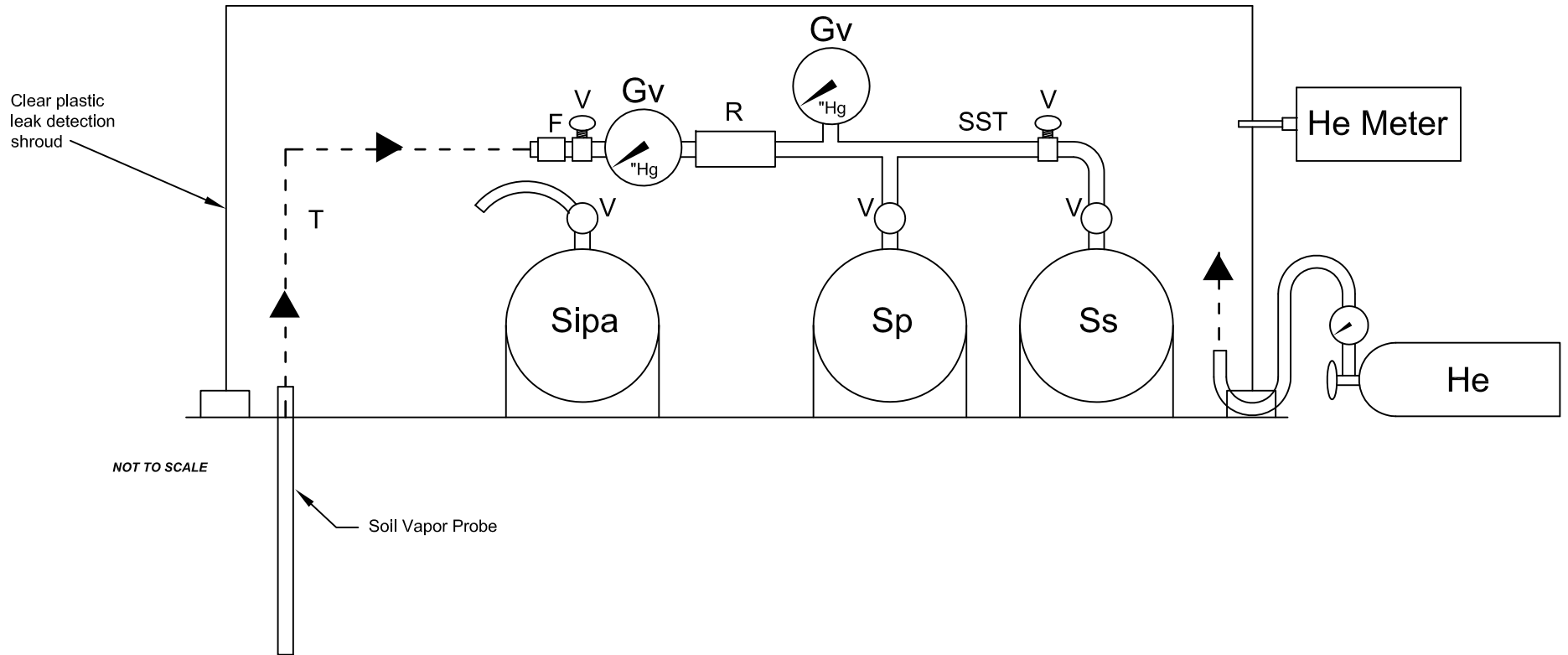

LEGEND

F	=	Filter
V	=	Valve
Gp	=	Pressure Gauge
R	=	Flow Regulator
Gv	=	Vacuum Gauge
Sp	=	Purge Summa Canister
Ss	=	Sample Summa Canister
Sipa	=	Ambient Air Helium Leak Detect Gas Summa Canister
He Meter	=	Helium detector for He concentration readings
T	=	Disposable Teflon or Polyethylene Tubing
SST	=	Stainless Steel Tubing and Fittings
He	=	Helium tank, leak detect gas, regulator and tubing



STANDARD OPERATING PROCEDURE
SOIL VAPOR SAMPLING
HELIUM SHROUD
SOURCE: ALLWEST
PREPARED BY: C. RAMELB

Appendix D



APPLICATION FOR AUTHORIZATION TO USE

REPORT TITLE: ADDITIONAL SUB-SLAB SOIL VAPOR INVESTIGATION
O'REILLY AUTO PARTS (FORMER GRAND AUTO #43)
4240 INTERNATIONAL BOULEVARD (EAST 14TH STREET)
OAKLAND, CALIFORNIA

PROJECT NUMBER: 12088.23

To: AllWest Environmental, Inc.
530 Howard Street, Suite 300
San Francisco, CA 94105

From (Applicant): _____

(Please clearly identify name and address of person/entity applying for permission to use or copy this document)

Ladies and Gentlemen:

Applicant hereby applies for permission to rely upon AllWest=s work product, as described above, for the purpose of: (state here the purpose for which you wish to rely upon the work product)

Applicant only can accept and rely upon AllWest work product under the strict understanding that Applicant is bound by all provisions in the Terms and Conditions attached to the report. Every report, recommendation, finding, or conclusion issued by AllWest shall be subject to the limitations stated in the Agreement and subject report(s). If this is agreeable, please sign below and return one copy of this letter to us along with the applicable fees. Upon receipt and if acceptable, our signed letter will be returned. AllWest may withhold permission at its sole discretion or require additional re-use fees or terms.

FEES: A \$1,250 coordination and reliance fee, payable in advance, will apply. If desired, for an additional \$100 report reproduction fee, we will reissue the report in the name of the Applicant; the report date, however, will remain the same. All checks will be returned if your request for reliance is not approved.

REQUESTED BY

APPROVED BY

Applicant Company

AllWest Environmental, Inc.

Print Name and Title

Print Name and Title

Signature and Date

Signature and Date

GENERAL CONDITIONS TO THE WORK AUTHORIZATION AGREEMENT

It is hereby agreed that the Client retains AllWest to provide services as set forth in the Work Authorization attached hereto (the "Work"). This contract shall be controlled by the following terms and conditions, and these terms and conditions shall also control any further assignments performed pursuant to this Work Authorization. Client's signature on this Work Authorization constitutes Client's agreement to the General Conditions.

Client agrees that AllWest is responsible only for the services set forth within the Scope of Work. In addition to the services to be performed by AllWest as described in the Work Authorization, the following items shall for the purposes of this Agreement be termed "Additional Services": (a) work resulting from changes in scope or magnitude of the Work as described therein, (b) work resulting from changes necessary because of construction cost over-runs, (c) work resulting from implementation of alternative or different designs from that first contemplated by the Parties, (d) work resulting from corrections or revisions required because of errors or omissions in construction by the building contractors, (e) work due to extended design or construction time schedules, (f) layout surveys in review of in-place constructed elements, and (g) services as an expert witness in connection with any public hearing, arbitration or proceedings of a court of record with respect to the Work on the Project. AllWest will be compensated by Client for any Additional Services on a time and materials basis in accordance with rates specified under the Work Authorization with appropriate fee increases for inflation. The Client is solely responsible for making any disclosures or reports to any third party and for the taking of corrective, remedial, or mitigative action.

FEES AND COSTS

1. AllWest shall charge for work performed by its personnel at the rates identified in the Work Authorization. These rates are subject to reasonable increases by AllWest upon giving Client 30 days advance notice. Reimbursable Costs will be charged to the Client in addition to the fees for the basic services under this Agreement and all Additional Services (defined below) under the Agreement. Reimbursable Costs include, but are not limited to, expenses for travel, including transportation, meals, lodging, long distance telephone and other related expenses, as well as the costs of reproduction of all drawings for the Client's use, costs for specifications and type-written reports, permit and approval fees, automobile travel reimbursement, costs and fees of subcontractors, and soil and other materials testing. No overtime is accrued for time spent in travel. All costs incurred which relate to the services or materials provided by a contractor or subcontractor to AllWest shall be invoiced by AllWest on the basis of cost plus twenty percent (20%). Automobile travel reimbursement shall be at the rate of fifty-eight cents (\$0.58) per mile. All other reimbursable costs shall be invoiced and billed by AllWest at the rate of 1.1 times the direct cost to AllWest. Reimbursable costs will be charged to the client only as outlined in the Work Authorization if the scope of work is for Phase I Environmental Site Assessment, Property Condition Assessment, Seismic Assessment or ALTA survey. Invoices for work performed shall be submitted monthly. Payment will be due upon receipt of invoice. Client shall pay interest on the balance of unpaid invoices which are overdue by more than 30 days, at a rate of 18% per annum as well as all attorney fees and costs incurred by AllWest to secure payment of unpaid invoices. AllWest may waive such fees at its sole discretion.

LIMITATION OF LIABILITY

2. AllWest will perform its work in accordance with the existing standard of care of its industry, as of the time of the work being performed in that locale. AllWest makes no warranties, express or implied regarding its work. Client expressly agrees that to the fullest extent permitted by law, AllWest's maximum liability, as well as that of its employees and agents, to Client for any claims arising from AllWest's services, shall be \$50,000 or its fees, whichever is higher. In the event Client makes a written request for a higher limitation of liability, AllWest may increase this limit for a mutually negotiated higher fee commensurate with the increased risk to AllWest, provided however, that such agreed increase in fee and limitation of liability amount is memorialized by separate written agreement which expressly amends the terms of this clause. As used in this paragraph, the term "liability" means liability of any kind, whether in contract (including breach of warranty), in tort (including negligence), in strict liability, or otherwise, for any and all injuries, claims, losses, expenses, or damages whatsoever arising out of or in any way related to AllWest's services or the services of AllWest's subcontractors, consultants, agents, officers, directors, and employees from any cause(s). AllWest shall not be liable for any claims of loss of profits or any other indirect, incidental, or consequential damages of any nature whatsoever.

INDEMNIFICATION

3. Notwithstanding any other provision of this Agreement, Client agrees, to the fullest extent permitted by law, to waive any claim against, release from any liability or responsibility for, and to assume the defense of, indemnify and hold harmless AllWest, its employees, agents and sub-consultants (collectively, Consultant) from and against any and all damages, liabilities, claims, actions or costs of any kind, including reasonable attorney's fees and defense costs, arising or alleged to arise out of or to be in any way connected with the Project or the performance or non-performance of Consultant of any services under this Agreement, excepting only any such liabilities determined by a court or other forum of competent jurisdiction to have been caused by the negligence or willful misconduct of Consultant. This provision shall be in addition to any rights of indemnity that Consultant may have under the law and shall survive and remain in effect following the termination of this Agreement for any reason. Should any part of this provision be determined to be unenforceable, AllWest and Client agree that the rest of the provision shall apply to the maximum extent permitted by law. The Client's duty to defend AllWest shall arise immediately upon tender of any matter potentially covered by the above obligations to indemnify and hold harmless.

MEDIATION & JUDICIAL REFERENCE

4. In an effort to resolve any conflicts or disputes that arise regarding the performance of this agreement, the Client & AllWest agree that all such disputes shall be submitted to non-binding mediation, using a mutually agreed upon mediation service experienced in the resolution of construction disputes. Unless the parties mutually agree otherwise, such mediation shall be a condition precedent to the initiation of any other adjudicative proceedings. It is further agreed that any dispute that is not settled pursuant to such mediation shall be adjudicated by a court appointed referee in accordance with the Judicial Reference procedures as set forth in California Code of Civil Procedure Section 638 et seq. The parties hereby mutually agree to waive any right to a trial by jury regarding any dispute arising out of this agreement.

The parties further agree to include a similar mediation, Judicial Reference & waiver of jury trial provision in their agreements with other independent contractors & consultants retained for the project and require them to similarly agree to these dispute resolution procedures. The cost of said Mediation shall be split equally between the parties. This agreement to mediate shall be specifically enforceable under the prevailing law of the jurisdiction in which this agreement was signed.

HAZARDOUS WASTE

5. Client acknowledges that AllWest and its sub-contractors have played no part in the creation of any hazardous waste, pollution sources, nuisance, or chemical or industrial disposal problem, which may exist, and that AllWest has been retained for the sole purpose of performing the services set out in the scope of work within this Agreement, which may include, but is not necessarily limited to such services as assisting the Client in assessing any problem which may exist and in assisting the Client in formulating a remedial program. Client acknowledges that while necessary for investigations, commonly used exploration methods employed by AllWest may penetrate through contaminated materials and serve as a connecting passageway between the contaminated material and an uncontaminated aquifer or groundwater, possibly inducing cross contamination. While back-filling with grout or other means, according to a state of practice design is intended to provide a seal against such passageway, it is recognized that such a seal may be imperfect and that there is an inherent risk in drilling borings of performing other exploration methods in a hazardous waste site.

AllWest will not sign or execute hazardous waste manifests or other waste tracking documents on behalf of Client unless Client specifically establishes AllWest as an express agent of Client under a written agency agreement approved by AllWest. In addition, Client agrees that AllWest shall not be required to sign any documents, no matter requested by whom, that would have the effect of AllWest providing any form of certification, guarantee, or warranty as to any matter or to opine on conditions for which the existence AllWest cannot ascertain. Client also agrees that it shall never seek or otherwise attempt to have AllWest provide any form of such certification, guarantee or warranty in exchange for resolution of any disputes between Client and AllWest, or as a condition precedent to making payment to AllWest for fees and costs owing under this Agreement.

Client understands and agrees that AllWest is not, and has no responsibility as, a generator, operator, treater, storer, transporter, arranger or disposer of hazardous or toxic substances found or identified at the site, including investigation-derived waste. The Client shall undertake and arrange for the removal, treatment, storage, disposal and/or treatment of hazardous material and investigation derived waste (such as drill cuttings). AllWest's responsibilities shall be limited to recommendations regarding such matters and assistance with appropriate arrangements if authorized by Client.

FORCE MAJUERE

6. Neither party shall be responsible for damages or delays in performance under this Agreement caused by acts of God, strikes, lockouts, accidents or other events or condition (other than financial inability) beyond the other Party's reasonable control.

TERMINATION

7. This Agreement may be terminated by either party upon seven (7) days' written notice should the other party substantially fail to perform in accordance with its duties and responsibilities as set forth in this Agreement and such failure to perform is through no fault of the party initiating the termination. Client agrees that if it chooses to terminate AllWest for convenience, and AllWest has otherwise satisfactorily performed its obligations under this Agreement to that point, AllWest shall be paid no less than eighty percent (80%) of the contract price, provided, however, that if AllWest shall have completed more than eighty percent of the Work at the time of said termination, AllWest shall be compensated as provided in the Work Authorization for all services performed prior to the termination date which fall within the scope of work described in the Work Authorization and may as well, at its sole discretion and in accordance with said Schedule of Fees, charge Client, and Client agrees to pay AllWest's reasonable costs and labor in winding up its files and removing equipment and other materials from the Project.

Upon notice of termination by Client to AllWest, AllWest may issue notice of such termination to other consultants, contractors, subcontractors and to governing agencies having jurisdiction over the Project, and take such other actions as are reasonably necessary in order to give notice that AllWest is no longer associated with the Project and to protect AllWest from claims of liability from the work of others.

DOCUMENTS

8. Any documents prepared by AllWest, including, but not limited to proposals, project specifications, drawings, calculations, plans and maps, and any ideas and designs incorporated therein, as well as any reproduction of the above are instruments of service and shall remain the property of AllWest and AllWest retains copyrights to these instruments of service. AllWest grants to Client a non-exclusive license to use these instruments of service for the purpose of completing and maintaining the Project. The Client shall be permitted to retain a copy of any instruments of service, but Client expressly agrees and acknowledges that the instruments of service may not be used by the Client on other projects, or for any other purpose, except the current one, unless Client first obtains a written agreement expanding the license to such use from AllWest, and with appropriate compensation to AllWest.

Client shall furnish, or cause to be furnished to AllWest all documents and information known to Client that relate to the identity, location, quantity, nature, or characteristics of any asbestos, PCBs, or any other hazardous materials or waste at, on or under the site. In addition, Client will furnish or cause to be furnished such reports, data, studies, plans, specifications, documents and other information on surface or subsurface site conditions, e.g., underground tanks, pipelines and buried utilities, required by AllWest for proper performance of its services. IF Client fails to provide AllWest with all hazardous material subject matter reports including geotechnical assessments in its possession during the period that AllWest is actively providing its services (including up to 30 days after its final invoice), Client shall release AllWest from any and all liability for risks and damages the Client incurs resulting from its reliance on AllWest's professional opinion. AllWest shall be entitled to rely upon Client - provided documents and information in performing the services required in this Agreement; however, AllWest assumes no responsibility or liability for the accuracy or completeness of Client-provided documents. Client-provided documents will remain the property of the Client.

ACCESS TO PROJECT

9. Client grants to AllWest the right of access and entry to the Project at all times necessary for AllWest to perform the Work. If Client is not the owner of the Project, then Client represents that Client has full authority to grant access and right of entry to AllWest for the purpose of AllWest's performance of the Work. This right of access and entry extends fully to any agents, employees, contractors or subcontractors of AllWest upon reasonable proof of association with AllWest. Client's failure to provide such timely access and permission shall constitute a material breach of this Agreement excusing AllWest from performance of its duties under this Agreement.

CONFIDENTIAL INFORMATION

10. Both Client and AllWest understand that in conjunction with AllWest's performance of the Work on the project, both Client and AllWest may receive or be exposed to Proprietary Information of the other. As used herein, the term "Proprietary Information" refers to any and all information of a confidential, proprietary or secret nature which may be either applicable to, or relate in any way to: (a) the personal, financial or other affairs of the business of each of the Parties, or (b) the research and development or investigations of each of the Parties. Proprietary Information includes, for example and without limitation, trade secrets, processes, formulas, data, know-how, improvements, inventions, techniques, software technical data, developments, research projects, plans for future development, marketing plans and strategies. Each of the Parties agrees that all Proprietary Information of the other party is and shall remain exclusively the property of that other party. The parties further acknowledge that the Proprietary Information of the other party is a special, valuable and unique asset of that party, and each of the Parties agrees that at all times during the terms of this Agreement and thereafter to keep in confidence and trust all Proprietary Information of the other party, whether such Proprietary Information was obtained or developed by the other party before, during or after the term of this Agreement. Each of the Parties agrees not to sell, distribute, disclose or use in any other unauthorized manner the Proprietary Information of the other party. AllWest further agrees that it will not sell, distribute or disclose information or the results of any testing obtained by AllWest during the performance of the Work without the prior written approval of Client unless required to do so by federal, state or local statute, ordinance or regulation.

INDEPENDENT CONTRACTOR

11. Both Client and AllWest agree that AllWest will act as an independent contractor in the performance of the Work under this Agreement. All persons or parties employed by AllWest in connection with the Work are the agents, employees or subcontractors of AllWest and not of Client. Accordingly, AllWest shall be responsible for payment of all taxes arising out of AllWest's activities in performing the Work under this Agreement.

ENTIRE AGREEMENT

12. This Agreement contains the entire agreement between the Parties pertaining to the subject matter contained in it and supersedes and replaces in its entirety all prior and contemporaneous proposals, agreements, representations and understandings of the Parties. The Parties have carefully read and understand the contents of this Agreement and sign their names to the same as their own free act.

MODIFICATION / WAIVER / PARTIAL INVALIDITY

13. The terms of this Agreement may be modified only by a writing signed by both Parties. Failure on the part of either party to complain of any act or omission of the other, or to declare the other party in default, shall not constitute a waiver by such party of its rights hereunder. If any provision of this Agreement or its application be unenforceable to any extent, the Parties agree that the remainder of this Agreement shall not be affected and shall be enforced to the greatest extent permitted by law.

INUREMENT / TITLES

14. Subject to any restrictions on transfers, assignments and encumbrances set forth herein, this Agreement shall inure to the benefit of and be binding upon the undersigned Parties and their respective heirs, executors, legal representatives, successors and assigns. Paragraph titles or captions contained in this Agreement are inserted only as a matter of convenience, and for reference only, and in no way limit, define or extend the provisions of any paragraph. , et al., incurred in that action or proceeding, in addition to any other relief to which it or they may be entitled.

INTERPRETATION / ADDITIONAL DOCUMENTS

15. The words "Client" and "AllWest" as used herein shall include the plural as well as the singular. Words used in the neuter gender include the masculine and feminine. Words used in the masculine gender include the feminine and neuter. If there is more than one Client, the obligations hereunder imposed on Client shall be joint and several. The terms of this Agreement were fully negotiated by the Parties and shall not be construed for or against the Client or AllWest but shall be interpreted in accordance with the general meaning of the language in an effort to reach the intended result.

AUTHORITY

16. Each of the persons executing this Agreement on behalf of a corporation does hereby covenant and warrant that the corporation is duly authorized and existing under the laws of its respective state of incorporation, that the corporation has and is qualified to do business in its respective state of incorporation, that the corporation has the full right and authority to enter into this Agreement, and that each person signing on behalf of the corporation is authorized to do so. If the Client is a joint venture, limited liability company or a partnership, the signatories below warrant that said entity is properly and duly organized and existing under the laws of the state of its formation and pursuant to the organizational and operating document of the entity, and the laws of the state of its formation, said signatory has authority act on behalf of and commit the entity to this Agreement.

COUNTERPARTS

17. This Agreement may be signed in counterparts by each of the Parties hereto and, taken together, the signed counterparts shall constitute a single document.

THIRD PARTY BENEFICIARIES / CONTROLLING LAW

18. There are no intended third party beneficiaries of this Agreement. The services, data & opinions expressed by AllWest are for the sole use of the client, are for a particular project and may not be relied upon by anyone other than the client. This Agreement shall be controlled by the laws of the State of California and any action by either party to enforce this Agreement shall be brought in San Francisco County, California.

TIME BAR TO LEGAL ACTION

19. All legal actions by either party against the other related to this Agreement, shall be barred after one year has passed from the time the claimant knew or should have known of its claim, and under no circumstances shall be initiated after two years have passed from the date by which AllWest completes its services.