

ALAMEDA COUNTY  
HEALTH CARE SERVICES

AGENCY

DAVID J. KEARS, Agency Director



7

ENVIRONMENTAL HEALTH SERVICES  
ENVIRONMENTAL PROTECTION  
1131 Harbor Bay Parkway, Suite 250  
Alameda, CA 94502-6577  
(510) 567-6700  
FAX (510) 337-9335

July 13, 2005

Denis Brown  
Shell Oil Products US  
20945 S. Wilmington Ave.  
Carson, CA 90810-1039

Subject: Fuel Leak Case No. [REDACTED] Shell, 9750 Golf Links Road, Oakland, CA

Dear Mr. Brown:

Alameda County Environmental Health (ACEH) staff has reviewed the case file and the reports entitled, "Site Investigation Report," dated May 5, 2005 and "Groundwater Monitoring Report – First Quarter 2005," dated June 7, 2005 prepared for the above referenced site on behalf of Shell by Cambria Environmental Technology, Inc. The "Site Investigation Report" presents soil sampling results from four soil borings and the "Groundwater Monitoring Report – First Quarter 2005," presents results for groundwater samples collected on March 23, 2005. Groundwater monitoring at the site has detected elevated concentrations of methyl tert-butyl ether (MTBE) in groundwater samples collected at the site. Based on staff review of the documents referenced above, we request that you address the following technical comments and send us the reports described below.

**TECHNICAL COMMENTS**

- 1. Proposed Well S-3.** The "Site Investigation Report" indicates that well S-3 could not be installed and that well S-4 was relocated midway between the original locations for wells S-3 and S-4. Only a brief comment is provided in Table 1 regarding attempts to install well S-3. Please provide additional descriptions of the difficulties encountered in installing well S-3. The text of the report refers to "underground lithologic conditions, and/or underground utilities, and pea-gravel," interfering with well installation. In the revised report requested below, please fully describe the encountered conditions and how they affected well installation.
- 2. Locations of Storm Drains and Culvert.** Figure 2 in each of the two above referenced reports shows the approximate location of a 6-foot by 10-foot culvert beneath Golf Links Road. Previous reports and the work plan for this well installation ("Site Investigation Report and Well Installation Work Plan" dated July 19, 2004) have shown the culvert in a significantly different location along the western side of the site. The location of the culvert is a factor in assessing site characterization and groundwater sampling results. Previous reports ("Subsurface Investigation Report" dated June 7, 2000) have observed that fill material near the culvert may act as a conduit to Arroyo Viejo Creek. Please clarify in the revised report requested below, which is the correct location for the culvert and revise the site maps, if necessary.

3. **Surface Water Sampling from Arroyo Viejo Creek.** Collection of surface water samples from Arroyo Viejo Creek was proposed in the document entitled, "Agency Response and Well Installation Work Plan Addendum," dated December 5, 2002; however, no sampling results appear to have been presented in subsequent reports. Please confirm whether surface water samples have been collected from Arroyo Creek. If surface water sampling has not been conducted and future sampling is not planned, present the rationale for not collecting these samples. This information is to be presented in the revised report requested below.
4. **Cross Sections.** The revised report is to include one north-south and one east-west cross section. Each cross section should include the following:
  - Surface topography. The cross sections should be extended off-site where necessary to show significant breaks in slope.
  - Soil descriptions for all borings and wells along the line of section.
  - Screen and filter pack intervals for each monitoring well.
  - Sampling locations and results for soil and grab groundwater samples.
  - Site features such as the tank pit, dispensers, etc.
5. **Groundwater Monitoring.** Quarterly groundwater monitoring is to be implemented for the four groundwater monitoring wells at the site. Groundwater samples are to be analyzed for total petroleum hydrocarbons, benzene, toluene, ethylbenzene, xylenes, MTBE, and fuel oxygenates using EPA Method 8260B. Groundwater monitoring results are to be presented in the reports requested below.

#### **TECHNICAL REPORT REQUEST**

Please submit technical reports to Alameda County Environmental Health (Attention: Mr. Jerry Wickham), according to the following schedule:

- **August 30, 2005** - Quarterly Report for the Second Quarter 2005
- **September 13, 2005** - Revised Site Investigation Report
- **November 30, 2005** - Quarterly Report for the Third Quarter 2005
- **February 28, 2006** - Quarterly Report for the Fourth Quarter 2005

These reports are being requested pursuant to California Health and Safety Code Section 25296.10. 23 CCR Sections 2652 through 2654, and 2721 through 2728 outline the responsibilities of a responsible party in response to an unauthorized release from a petroleum UST system, and require your compliance with this request.

#### **PERJURY STATEMENT**

All work plans, technical reports, or technical documents submitted to ACEH must be accompanied by a cover letter from the responsible party that states, at a minimum, the following: "I declare, under penalty of perjury, that the information and/or recommendations contained in the attached document or report is true and correct to the best of my knowledge." This letter must be signed by an officer or legally authorized representative of your company. Please include a cover

Denis Brown  
July 13, 2005  
Page 3

letter satisfying these requirements with all future reports and technical documents submitted for this fuel leak case.

**PROFESSIONAL CERTIFICATION & CONCLUSIONS/RECOMMENDATIONS**

The California Business and Professions Code (Sections 6735, 6835, and 7835.1) requires that work plans and technical or implementation reports containing geologic or engineering evaluations and/or judgments be performed under the direction of an appropriately registered or certified professional. For your submittal to be considered a valid technical report, you are to present site specific data, data interpretations, and recommendations prepared by an appropriately licensed professional and include the professional registration stamp, signature, and statement of professional certification. Please ensure all that all technical reports submitted for this fuel leak case meet this requirement.

**UNDERGROUND STORAGE TANK CLEANUP FUND**

Please note that delays in investigation, later reports, or enforcement actions may result in your becoming ineligible to receive grant money from the state's Underground Storage Tank Cleanup Fund (Senate Bill 2004) to reimburse you for the cost of cleanup.

**AGENCY OVERSIGHT**

If it appears as though significant delays are occurring or reports are not submitted as requested, we will consider referring your case to the Regional Board or other appropriate agency, including the County District Attorney, for possible enforcement actions. California Health and Safety Code, Section 25299.76 authorizes enforcement including administrative action or monetary penalties of up to \$10,000 per day for each day of violation.

If you have any questions, please call me at (510) 567-6791.

Sincerely,

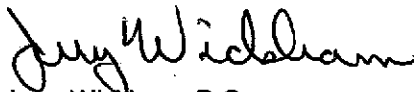

Jerry Wickham, P.G.  
Hazardous Materials Specialist

cc: Ana Friel  
Cambria Environmental Technology, Inc.  
270 Perkins Street  
Sonoma, CA 95406

Donna Drogos, ACEH  
Jerry Wickham, ACEH  
File

R-2441

**Hwang, Don, Env. Health**

---

**From:** Hwang, Don, Env. Health  
**Sent:** Tuesday, June 08, 2004 5:04 PM  
**To:** 'afriel@Cambria-env.com'  
**Subject:** RE: 9750 Golf Links Road, Oakland - Status

Ana, ok Don

-----Original Message-----

**From:** Friel, Ana [mailto:afriel@Cambria-env.com]  
**Sent:** Monday, June 07, 2004 2:49 PM  
**To:** Don Hwang  
**Cc:** Karen Petryna  
**Subject:** 9750 Golf Links Road, Oakland - Status

Don,

In a previous correspondence, we had expected to begin our field work at this site (pilot-hole boring) on April 12, 2004. However, due to facility upgrades/construction work at the station, we had to re-schedule the drilling activities. The pilot-hole boring was initiated this morning (June 7). Because of the adjusted field schedule, we respectfully request an extension for submittal of the Technical Report of these activities to July 20<sup>th</sup>.

Please let me know if there is any problem with this request. We will submit the report and work plan as soon as possible, and no later than July 20<sup>th</sup>.

Regards,

Ana Friel  
Senior Project Geologist  
Cambria Environmental Technology  
707-442-2700

May 18, 2004

Don Hwang  
Hazardous Materials Specialist  
Alameda County Health Care Services Agency  
1131 Harbor Bay Parkway, Suite 250  
Alameda, California 94502-6577

Re: **Request for Extension of Technical Report**  
Shell Service Station  
9750 Golf Links Road  
Oakland, California  
Incident No. 98995744  
**ACHCSA Fuel Leak Case No. RO0002441**



Dear Mr. Hwang:

Cambria Environmental Technology, Inc. (Cambria) prepared this letter on behalf of Equilon Enterprises LLC dba Shell Oil Products US (Shell) to request an extension for the submittal of the technical report that is currently due June 5, 2004. In correspondence dated March 17, 2004, Cambria notified the Alameda County Health Care Services Agency (ACHCSA) of Shell's intent to proceed with the installation of one pilot bore hole at the subject site. The purpose of the pilot boring is to gain information regarding site conditions that would allow us to make appropriate recommendations for site investigation activities. In a letter dated April 5, 2004, the ACHCSA provided written approval of the proposed pilot boring and requested a technical report be submitted by June 5, 2004.

The field work was scheduled to occur on April 12, 2004, but was re-scheduled due to facility upgrade activities occurring at the station. The work was re-scheduled for May 10, 2004; however, the week prior to these activities, we were notified that the facility upgrades were not yet completed due to an increased scope of work. Therefore, Cambria re-scheduled the installation of the pilot boring for June 8, 2004, based on the driller's equipment availability.

Given the new field schedule, we respectfully request an **extension for the technical report to July 20, 2004**. We appreciate your consideration in this matter. Please contact Ana Friel at (707) 442-2700 if you have any questions or comments.

Sincerely,

**Cambria Environmental Technology, Inc.**

Ana Friel, RG  
Senior Project Geologist

**Cambria  
Environmental  
Technology, Inc.**

270 Perkins Street  
P.O. Box 259  
Sonoma, CA 95476  
Tel (707) 935-4850  
Fax (707) 935-6649

cc: Karen Petryna, Shell

ALAMEDA COUNTY  
HEALTH CARE SERVICES

AGENCY  
DAVID J. KEARS, Agency Director



Alameda County

APR 15 2004

Environmental Health

April 5, 2004

Karen Petryna  
Equiva Services LLC  
PO Box 7869  
Burbank, CA 91501-7869

ENVIRONMENTAL HEALTH SERVICES  
ENVIRONMENTAL PROTECTION  
1131 Harbor Bay Parkway, Suite 250  
Alameda, CA 94502-6577  
(510) 567-6700  
FAX (510) 337-9335

Dear Ms. Petryna:

Subject: Fuel Leak Case No. RO0002441, Shell Service Station, 9750 Golf Links Rd.,  
Oakland, CA

Thank you for your "Notice of Intent to Implement Work Plan" dated March 17, 2004. You intend to implement a portion of the scope of work presented in the *Agency Response and Well Installation Work Plan Addendum* dated December 4, 2002, prepared by Cambria Environmental Technology, by installing one pilot boring hole to 100 feet below grade. Then based on the results of the pilot boring, additional work will be proposed. Alameda County Environmental Health staff has reviewed "Agency Response and Well Installation Work Plan Addendum" dated December 4, 2002, prepared by Cambria Environmental Technology. We generally agree with your proposal. We request that you send us the technical report requested below.

TECHNICAL REPORT REQUEST

Please submit technical reports to the Alameda County Environmental Health (Attention: Don Hwang), according to the following schedule:

June 5, 2004 - Soil and Groundwater Investigation

These reports are being requested pursuant to the Regional Water Quality Control Board's (Regional Board) authority under Section 13267 of the California Water Code. If you have any questions, please call me at (510) 567-6746.

Sincerely,

Don Hwang  
Hazardous Materials Specialist

C: Ana Friel, Cambria Environmental Technology, Inc., 270 Perkins St., P.O. Box 259,  
Sonoma, CA 95476  
Donna Drogos  
File

4580



ALAMEDA COUNTY  
HEALTH CARE SERVICES AGENCY  
Environmental Health Services Administration  
1131 Harbor Bay Parkway, Suite 250  
Alameda, CA 94502-6577

Karen Petryna  
Equiva Services LLC  
PO Box 7869  
Burbank, CA

EQUIV69\* 915103065 1C03 47 04/10/04  
NOTIFY SENDER OF NEW ADDRESS  
EQUIVA SERVICES  
20945 S WILMINGTON AVE #S-E  
CARSON CA 90810-1039

94502-6577



C A M B R I A

Alameda County

MAR 22 2004

Environmental Health

March 17, 2004

Don Hwang  
Hazardous Materials Specialist  
Alameda County Health Care Services Agency  
1131 Harbor Bay Parkway, Suite 250  
Alameda, California 94502-6577

Re: **Notice of Intent to Implement Work Plan**  
Shell Service Station  
9750 Golf Links Road  
Oakland, California  
Incident No. 98995744



Dear Mr. Hwang:

Cambria Environmental Technology, Inc. (Cambria) prepared this letter on behalf of Equilon Enterprises LLC dba Shell Oil Products US (Shell) to notify the Alameda County Health Care Services Agency (ACHCSA) of our intent to implement a portion of the scope of work presented in the *Agency Response and Well Installation Work Plan Addendum* dated December 4, 2002.

Since more than 60 days have passed without any comment from the ACHCSA, we assume concurrence with the proposed activities, and hereby provide notification of our intent to initiate these activities by installing one pilot boring hole to 100 feet below grade beginning April 12, 2004. Based on the results of the pilot boring, a more defined scope of work for site assessment or monitoring well installation can be presented.

Please call Ana Friel at (707) 442-2700 if you have any questions or comments.

Sincerely,

**Cambria Environmental Technology, Inc.**

Ana Friel, RG  
Senior Project Geologist

cc: Karen Petryna, Shell

Cambria  
Environmental  
Technology, Inc.

270 Perkins Street  
P.O. Box 259  
Sonoma, CA 95476  
Tel (707) 935-4850  
Fax (707) 935-6649



ALAMEDA COUNTY  
HEALTH CARE SERVICES

AGENCY  
DAVID J. KEARS, Agency Director



ENVIRONMENTAL HEALTH SERVICES  
ENVIRONMENTAL PROTECTION  
1131 Harbor Bay Parkway, Suite 250  
Alameda, CA 94502-6577  
(510) 567-6700  
FAX (510) 337-9335

October 9, 2002

Karen Petryna  
Equiva Services LLC  
PO Box 7869  
Burbank, CA 91501-7869

Dear Ms. Petryna:

Subject: Fuel Leak Case No. RO0002441, Shell Service Station, 9750 Golf Links Rd.,  
Oakland, CA

Alameda County Environmental Health staff has reviewed "Well Installation Work Plan" dated May 17, 2002, prepared by Cambria Environmental Technology, and generally concur with the work proposed. We request that you address the following technical comments and send us the technical reports requested below.

TECHNICAL COMMENTS

1. **Monitoring Well Depths** – The only groundwater samples yielded thus far were from soil borings SB-2 at 12 feet below grade (fbg) and SB-3 at 20 fbg. Both were attributed to a perched water zone. The depths for onsite wells ranged from 16 to 48 fbg. In 2000, a sensitive receptor survey found only one well within a 1/4-mile survey radius. This was a cathodic protection well located approximately 1,150 feet north-northwest of the site with a depth of 120 fbg. No depth to groundwater was available. Include your proposal for determining monitoring well depths in the revised workplan requested below.
2. **Monitoring Well Locations** - We do not concur with one of the locations proposed, south of the former fuel tanks. We feel that this location may miss downgradient flow from the former fuel tanks although we do want a well within 10 feet of the former fuel tanks and another one within 10 feet of the former dispensers in the downgradient direction. Include your proposal to meet these requirements in the revised workplan requested below.
3. **Arroyo Viejo Creek Sampling** – Include a map showing your proposed sample locations in the revised workplan requested below.
4. **Soil and Groundwater Analyses** – Please analyze all soil and groundwater samples for Total Petroleum Hydrocarbons-Gasoline (TPH-G), Benzene, Toluene, Ethyl Benzene, Xylene (BTEX), and MTBE. Additionally, for groundwater samples, analyses for the fuel oxygenates MTBE, Tertiary Amyl Methyl Ether (TAME), Ethyl Tertiary Butyl Ether

8260, is required. After the initial round of sampling, sample for any of these contaminants found in subsequent quarters. Include these analyses in the revised workplan requested below.

5. B1 Boring – Missing log. Submit.
6. Legitimacy Statement – All technical reports shall be accompanied by a letter signed by an officer or legally authorized representative of the responsible party that states, at a minimum: "I declare, under penalty of perjury, that the information and/or recommendations contained in the attached proposal or report is true and correct to the best of my knowledge."
7. Vicinity hydrogeologic setting - Include in the revised workplan requested below.

#### TECHNICAL REPORT REQUEST

Please submit technical reports to the Alameda County Environmental Health (Attention: Don Hwang), according to the following schedule:

December 9, 2002 - Revised Workplan.

These reports are being requested pursuant to the Regional Water Quality Control Board's (Regional Board) authority under Section 13267 of the California Water Code. If you have any questions, please call me at (510) 567-6746.

Sincerely,

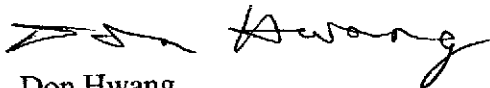

Don Hwang  
Hazardous Materials Specialist  
Local Oversight Program

C: Jacquelyn Jones, Cambria Environmental Technology, Inc., 1144-65<sup>th</sup> St., Suite B,  
Oakland, CA 94608

√ File

ALAMEDA COUNTY  
HEALTH CARE SERVICES

AGENCY  
DAVID J. KEARS, Agency Director



ENVIRONMENTAL HEALTH SERVICES  
ENVIRONMENTAL PROTECTION  
1131 Harbor Bay Parkway, Suite 250  
Alameda, CA 94502-6577  
(510) 567-6700  
FAX (510) 337-9335

March 29, 2002

Karen Petryna  
Equiva Services LLC  
PO Box 7869  
Burbank, CA 91501-7869

Dear Ms. Petryna:

Subject: Fuel Leak Case No. RO0002441, Shell Service Station, 9750 Golf Links Rd.,  
Oakland, CA

Alameda County Environmental Health staff has reviewed "Subsurface Investigation Report" dated June 7, 2000, prepared by Cambria Environmental Technology. We request that you address the following technical comments, perform the proposed work, and send us the technical reports requested below.

TECHNICAL COMMENTS

1. Groundwater Monitoring – The extent of groundwater contamination at your site is undefined. There are no groundwater monitoring wells onsite. Five borings, SB-1b, SB-2, SB-3, SB-4, and SB-5 were installed on August 25, 1999. Groundwater samples were collected from two borings, SB-2 and SB-3, at 12 feet below grade (fbg) and 20 fbg, respectively, with up to 11,800 u/g of Methyl Tertiary Butyl Ether (MTBE) detected. Groundwater was not found in borings, SB-1b, SB-4, and SB-5, drilled to a maximum depth of 30 feet below ground surface. Characterization of groundwater contamination is required at your site. Please include your proposal for completing this work in the workplan requested below.
2. Arroyo Viejo Creek - Arroyo Viejo Creek is located approximately 650 feet southeast in the apparent downgradient direction of your site. Due to the presence of significant levels of MTBE, a compound that is more mobile in soil and groundwater than the typical petroleum hydrocarbon compounds at your site, we request that you collect and analyze water samples from the creek. Please include your proposal for creek sampling in the workplan requested below.

Ms. Petryna  
March 29, 2002  
Page 2 of 2

3. Soil and Groundwater Analyses – Please analyze all soil and groundwater samples for Total Petroleum Hydrocarbons-Gasoline (TPH-G), Benzene, Toluene, Ethyl Benzene, Xylene (BTEX), and MTBE. . Additionally, for groundwater samples, analyses for the fuel oxygenates MTBE, Tertiary Amyl Methyl Ether (TAME), Ethyl Tertiary Butyl Ether (ETBE), Di-Isopropyl Ether (DIPE), and Tertiary Butyl Alcohol (TBA), by EPA Method 8260, is required.

#### TECHNICAL REPORT REQUEST

Please submit technical reports to the Alameda County Environmental Health (Attention: Don Hwang), according to the following schedule:

May 29, 2002 - Workplan.

These reports are being requested pursuant to the Regional Water Quality Control Board's (Regional Board) authority under Section 13267 of the California Water Code. If you have any questions, please call me at (510) 567-6746.

Sincerely,

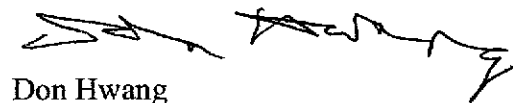

Don Hwang  
Hazardous Materials Specialist

C: Stephan Bork, Cambria Environmental Technology, Inc., 1144-65<sup>th</sup> St., Suite B,  
Oakland, CA 94608

✓ File



# State Water Resources Control Board



Gray Davis  
Governor

Winston H. Hickox  
Secretary for  
Environmental  
Protection

Division of Clean Water Programs  
1001 I Street • Sacramento, California 95814 • (916) 341-5714  
Mailing Address: P.O. Box 944212 • Sacramento, California • 94244-2120  
FAX (916) 341-5806 • Internet Address: <http://www.swrcb.ca.gov/cwphome/ustcf>

JAN 22 2001

Deborah Pryor % Equiva Services LLC  
Shell Oil Company  
P O Box 7869  
Burbank, CA 91510-7869

UNDERGROUND STORAGE TANK CLEANUP FUND PROGRAM, NOTICE OF ELIGIBILITY DETERMINATION: CLAIM NUMBER 016120; FOR SITE ADDRESS: 9750 GOLF LINKS RD, OAKLAND

Your claim has been accepted for placement on the Priority List in Priority Class "D" with a deductible of \$10,000.

We have completed our initial review. The next step in the claim review process is to conduct a compliance review.

Compliance Review: Staff reviews, verifies, and processes claims based on the priority and rank within a priority class. After the Board adopts the Priority List, your claim will remain on the Priority List until your Priority Class and rank are reached. At that time, staff will conduct an extensive Compliance Review at the local regulatory agency or Regional Water Quality Control Board. During this Compliance Review, staff may request additional information needed to verify eligibility. Once the Compliance Review is completed, staff will determine if the claim is valid or must be rejected. If the claim is valid, a Letter of Commitment will be issued obligating funds toward the cleanup. If staff determine that you have not complied with regulations governing site cleanup, you have not supplied necessary information or documentation, or your claim application contains a material error, the claim will be rejected. In such event, you will be issued a Notice of Intended Removal from the Priority List, informed of the basis for the proposed removal of your claim, and provided an opportunity to correct the condition that is the basis for the proposed removal. Your claim will be barred from further participation in the Fund, if the claim application contains a material error resulting from fraud or intentional or negligent misrepresentation.

Record keeping: During your cleanup project you should keep complete and well organized records of all corrective action activity and payment transactions. If you are eventually issued a Letter of Commitment, you will be required to submit: (1) copies of detailed invoices for all corrective action activity performed (including subcontractor invoices), (2) copies of canceled checks used to pay for work shown on the invoices, (3) copies of technical documents (bids, narrative work description, reports), and (4) evidence that the claimant paid for the work performed (not paid by another party). These documents are necessary for reimbursement and failure to submit them could impact the amount of reimbursement made by the Fund. *It is not necessary to submit these documents at this time; however, they will definitely be required prior to reimbursement.*

Compliance with Corrective Action Requirements: In order to be reimbursed for your eligible costs of cleanup incurred after December 2, 1991, you must have complied with corrective action requirements of Article 11, Chapter 16, Division 3, Title 23, California Code of Regulations. Article 11 categorized the corrective action process into *phases*. In addition, Article 11 requires the responsible party to submit an

California Environmental Protection Agency

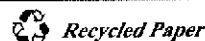

ENVIRONMENTAL PROTECTION  
00 JAN 24 PM 2: 59

**investigative workplan/Corrective Action Plan (CAP)** before performing any work. This phasing process and the workplan/CAP requirements were intended to:

1. help the responsible party undertake the necessary corrective action in a cost-effective, efficient and timely manner;
2. enable the regulatory agency to review and approve the proposed cost-effective corrective action alternative before any corrective action work was performed; and
3. ensure the Fund will only reimburse the most cost-effective corrective action alternative required by the regulatory agency to achieve the minimum cleanup necessary to protect human health, safety and the environment.

In some limited situations **interim cleanup** will be necessary to mitigate a demonstrated immediate hazard to public health, or the environment. Program regulations allow the responsible party to undertake interim remedial action after: (1) notifying the regulatory agency of the proposed action, and; (2) complying with any requirements that the regulatory agency may set. Interim remedial action should only be proposed when necessary to mitigate an immediate demonstrated hazard. **Implementing interim remedial action does not eliminate the requirement for a CAP and an evaluation of the most cost-effective corrective action alternative.**

**Three bids and Cost Preapproval:** Only corrective action costs required by the regulatory agency to protect human health, safety and the environment can be claimed for reimbursement. You must comply with all regulatory agency time schedules and requirements and you must obtain three bids for any required corrective action. Unless waived in writing, you are required to obtain preapproval of costs for all future corrective action work. **If you do not obtain three bids and cost preapproval, reimbursement is not assured and costs may be rejected as ineligible.**

If you have any questions, please contact me at (916) 341-5714.

Sincerely,

## ORIGINAL SIGNED BY

Shari Knieriem  
Claims Review Unit  
Underground Storage Tank Cleanup Fund

cc: Mr. Steve Morse  
RWQCB, Region 2  
1515 Clay Street, Ste. 1400  
Oakland, CA 94612

Mr. Thomas Peacock ST ID#  
Alameda County EHD 3672  
1131 Harbor Bay Pkway, 2nd Fl.  
Alameda, CA 94502-6577

LOP - RECORD CHANGE REQUEST FORM

printed:  
06/21/2000

Mark Out What Needs Changing and Hand to LOP Data Entry  
(Name/Address changes go to Annual Programs Data Entry)

Insp: DH

AGENCY # : 10000      SOURCE OF FUNDS: F      SUBSTANCE: 8006619  
 StID : 3672      LOC: -0-  
 SITE NAME: Shell Oil Co.      DATE REPORTED : 02/20/1998  
 ADDRESS : 9750 -0 Golf Links Rd      DATE CONFIRMED: 02/19/1998  
 CITY/ZIP : Oakland      94605      MULTIPLE RPs. : N

SITE STATUS

CASE TYPE: O CONTRACT STATUS: 4      PRIOR CODE: 2A4      EMERGENCY RESP: -0-  
 RP SEARCH: S      DATE COMPLETED: 02/20/1998  
 PRELIMINARY ASMNT: u      DATE UNDERWAY: 02/04/1998      DATE COMPLETED: -0-  
 REM INVESTIGATION: u      DATE UNDERWAY: -0-      DATE COMPLETED: -0-  
 REMEDIAL ACTION: -      DATE UNDERWAY: -0-      DATE COMPLETED: -0-  
 POST REMED ACT MON: -      DATE UNDERWAY: -0-      DATE COMPLETED: -0-

ENFORCEMENT ACTION TYPE: 1      DATE ENFORCEMENT ACTION TAKEN: 04/10/1998  
 LUFT FIELD MANUAL CONSID: -0-  
 CASE CLOSED: -      DATE CASE CLOSED: -0-  
 DATE EXCAVATION STARTED : -0-      REMEDIAL ACTIONS TAKEN: -0-

RESPONSIBLE PARTY INFORMATION

RP#1-CONTACT NAME: Karen Petryna  
 COMPANY NAME: Equiva Services Llc  
 ADDRESS: P. O. Box 7869  
 CITY/STATE: Burbank, C A 91501-7869

INSPECTOR VERIFICATION:

NAME _____	SIGNATURE _____	DATE _____
------------	-----------------	------------

DATA ENTRY INPUT:

Name/Address Changes Only

Case Progress Changes

ANPPGMS _____	LOP _____	DATE _____
---------------	-----------	------------

LOP _____	DATE _____
-----------	------------

C A M B R I A

ENVIRONMENTAL  
PROTECTION

May 22, 2000

00 MAY 31 AM 10: 05

Mr. Scott Seery  
Alameda County Health Care Services Agency  
1131 Harbor Bay Parkway, 2nd Floor  
Alameda, California 94502

Re: **Quarterly Status Report - First Quarter 2000**  
Shell-branded Service Station  
9750 Golf Links Road  
Oakland, CA  
Incident No. 98995744

Dear Mr. Seery:

On behalf of Equiva Services LLC, Cambria Environmental Technology, Inc. is submitting this letter in accordance with the reporting requirements of 23 CCR 2652d.

### Current Quarter's Activities

No activities were required or performed at this site during the first quarter of 2000.

### Proposed Activities

A subsurface investigation was performed in August 1999 to evaluate the extent of petroleum hydrocarbons and MTBE in soil and groundwater at the site. Results of this investigation suggest that subsurface contaminants may be transported to the nearby creek via an underground utility conduit. Cambria proposed that four quarters of creek sampling be performed.

We appreciate the opportunity to work with you on this project. Please call us if you have any questions.

Sincerely,

**Cambria Environmental Technology, Inc.**

*Stephan Bork*  
Stephan Bork, R.G., C.E.G.  
Senior Project Geologist



Oakland, CA  
San Ramon, CA  
Sonoma, CA  
Portland, OR

**Cambria  
Environmental  
Technology, Inc.**

1144 65th Street  
Suite B  
Oakland, CA 94608  
Tel (510) 420-0700  
Fax (510) 420-9170

cc: Karen Petryna, Equiva Services LLC, P.O. Box 7869, Burbank California 91510-7869



November 23, 1999

Mr. Scott Seery  
Alameda County Health Care Services Agency  
1131 Harbor Bay Parkway, 2nd Floor  
Alameda, California 94502

**RE: Relocation of Equiva Services LLC West Coast Administrative Center**

Dear Mr. Seery:

Effective December 1, 1999, Equiva Services LLC will relocate its West Coast Administrative Center from Carson, California to Burbank, California. Please send future correspondence that would formerly have gone to the Carson address to the following address:

Karen Petryna  
Equiva Services LLC  
P.O. Box 7869  
Burbank, California 91501-7869

Thank you in advance for your assistance with this address change. Please do not hesitate to contact me if you have any questions.

Sincerely,



Karen Petryna P.E.  
Civil Engineer  
Equiva Services LLC  
Science & Engineering, West Coast  
(559) 645-9306  
(559) 645-5643 fax  
(510) 719-7182 mobile  
Email: kepetryna@equiva.com

3719	6039 College	Oak
<del>3672</del>	<del>9750 Golf Links</del>	"
1107	27 Wildwood	Pied
1646	4226 1st St.	Pleas
5807	5251 Hopyard	"
1673	3290 "	"
768	1784 150th	S. Coast
1507	15275 Washington	"

99 DEC -1 PM 2:43  
ENVIRONMENTAL  
PROTECTION

# C A M B R I A

November 23, 1999

Mr. Scott Seery  
Alameda County Health Care Services Agency  
1131 Harbor Bay Parkway, 2nd Floor  
Alameda, California 94502

**Re: Certified List of Record Fee Title Owners for:**  
Shell-branded Service Station  
9750 Golf Links Rd.  
Oakland, CA  
Incident No. 98995744

Dear Mr. Seery:

In accordance with section 25297.15(a) of Chapter 6.7 of the Health Safety Code and on behalf of Equiva Services LLC, we certify that the following is a complete list of current record fee title owners and their mailing addresses for the above site.

Equilon Enterprises LLC c/o Stewart Title Guaranty Company, 1980 Post Oak Blvd.,  
Suite 110, Houston, TX 77056

Sincerely,



Ailsa S. Le May, R.G.  
Senior Geologist

cc: Karen Petryna, Equiva Services LLC, P.O. Box 6249, Carson, California, 90749-6249

Oakland, CA  
Sonoma, CA  
Portland, OR  
Seattle, WA

**Cambria  
Environmental  
Technology, Inc.**

1144 65th Street  
Suite B  
Oakland, CA 94608  
Tel (510) 420-0700  
Fax (510) 420-9170

99 NOV 29 PM 4: 47  
ENVIRONMENTAL  
PROTECTION

ALAMEDA COUNTY  
HEALTH CARE SERVICES

AGENCY  
DAVID J. KEARS, Agency Director



July 6, 1999

ENVIRONMENTAL HEALTH SERVICES

1131 Harbor Bay Parkway, Suite 250  
Alameda, CA 94502-6577  
(510) 567-6700  
(510) 337-9335 (FAX)

STID 3672

Ms. Karen Petryna  
Equiva Services LLC  
P.O. Box 6249  
Carson, CA 90749-6249

RE: Shell Station, 9750 Golf Links Road, Oakland – Soil and Water Investigation

Dear Ms. Petryna:

I have reviewed the June 29, 1999 Cambria Environmental Technology, Inc. (Cambria) *Additional Investigation Work Plan* for the continuing assessment of this site. The cited Cambria work plan was prompted by the initial discovery of elevated fuel compound concentrations in soil sampled during dispenser upgrade work that occurred in early 1998, and a subsequent limited assessment performed during July 1998.

The cited Cambria work plan has been accepted as submitted.

I expect that this work plan will be implemented within 45 days of the date of this letter.

Please contact me at (510) 567-6783 should you have any questions and to inform me when field activities will begin.

Sincerely,



Scott O. Seery, CHMM  
Hazardous Materials Specialist

c: Chuck Headlee, RWQCB  
Leroy Griffin, Oakland Fire Department  
Darryk Ataide, Cambria Environmental Technology, Inc.  
1144 65<sup>th</sup> Street, Ste. B, Oakland, CA 94608

ALAMEDA COUNTY  
HEALTH CARE SERVICES

AGENCY  
DAVID J. KEARS, Agency Director



ENVIRONMENTAL HEALTH SERVICES  
ENVIRONMENTAL PROTECTION (LOP)  
1131 Harbor Bay Parkway, Suite 250  
Alameda, CA 94502-6577  
(510) 567-6700  
FAX (510) 337-9335

May 5, 1999

STID 3672

Ms. Karen Petryna  
Equiva Services LLC  
Science & Engineering, West Coast  
P.O. Box 6249  
Carson, CA 90749-6249

RE: Shell Service Station, 9750 Golf Links Road, Oakland

LANDOWNER NOTIFICATION AND PARTICIPATION REQUIREMENTS

Dear Ms. Petryna:

This letter is to inform you of new legislative requirements pertaining to cleanup and closure of sites where an unauthorized release of hazardous substance, including petroleum, has occurred from an underground storage tank (UST). Section 25297.15(a) of Ch. 6.7 of the Health & Safety Code requires the primary or active responsible party to notify all current record owners of fee title to the site of: 1) a site cleanup proposal, 2) a site closure proposal, 3) a local agency intention to make a determination that no further action is required, and 4) a local agency intention to issue a closure letter. Section 25297.15(b) requires the local agency to take all reasonable steps to accommodate responsible landowners' participation in the cleanup or site closure process and to consider their input and recommendations.

For purposes of implementing these sections, you have been identified as the primary or active responsible party. Please provide to this agency, within twenty (20) calendar days of receipt of this notice, a complete mailing list of all current record owners of fee title to the site. You may use the enclosed "list of landowners" form (sample letter 2) as a template to comply with this requirement. If the list of current record owners of fee title to the site changes, you must notify the local agency of the change within 20 calendar days from when you are notified of the change.

If you are the sole landowner, please indicate that on the landowner list form. The following notice requirements do not apply to responsible parties who are the sole landowner for the site.

LANDOWNER NOTIFICATION  
Re: 9750 Golf Links Road, Oakland  
May 5, 1999  
Page 2 of 2

In accordance with Section 25297.15(a) of Ch. 6.7 of the Health & Safety Code, you must certify to the local agency that all current record owners of fee title to the site have been informed of the proposed action before the local agency may do any of the following:

- 1) consider a cleanup proposal (corrective action plan)
- 2) consider a site closure proposal
- 3) make a determination that no further action is required
- 4) issue a closure letter

You may use the enclosed "notice of proposed action" form (sample letter 3) as a template to comply with this requirement. Before approving a cleanup proposal or site closure proposal, determining that no further action is required, or issuing a closure letter, the local agency will take all reasonable steps necessary to accommodate responsible landowner participation in the cleanup and site closure process and will consider all input and recommendations from any responsible landowner.

Please call me at (510) 567-6783 should you have any questions about the content of this letter.

Sincerely,

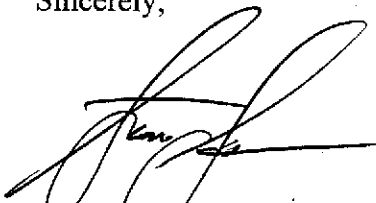

Scott O. Seery, CHMM  
Hazardous Materials Specialist

Attachments

cc: Chuck Headlee, RWQCB  
Leroy Griffin, Oakland Fire Department

SAMPLE LETTER (2): LIST OF LANDOWNERS FORM

---

Name of local agency  
Street address  
City

SUBJECT: CERTIFIED LIST OF RECORD FEE TITLE OWNERS FOR (*Site Name and Address*)

(Note: Fill out item 1 if there are multiple site landowners. If you are the sole site landowner, skip item 1 and fill out item 2.)

1. In accordance with section 25297.15(a) of Chapter 6.7 of the Health & Safety Code, I, (*name of primary responsible party*), certify that the following is a complete list of current record fee title owners and their mailing addresses for the above site:
  
2. In accordance with section 25297.15(a) of Chapter 6.7 of the Health & Safety Code, I, (*name of primary responsible party*), certify that I am the sole landowner for the above site.

Sincerely,

Signature of primary responsible party

Name of primary responsible party

SAMPLE LETTER 3: NOTICE OF PROPOSED ACTION SUBMITTED TO LOCAL AGENCY

---

Name of local agency  
Street address  
City

SUBJECT: NOTICE OF PROPOSED ACTION SUBMITTED TO LOCAL AGENCY  
FOR *(Site Name and Address)*

In accordance with section 25297,15(a) of Chapter 6.7 of the Health & Safety Code, I, *(name of primary responsible party)*, certify that I have notified all responsible landowners of the enclosed proposed action. Check space for applicable proposed action(s):

- cleanup proposal (corrective action plan)
- site closure proposal
- local agency intention to make a determination that no further action is required
- local agency intention to issue a closure letter

Sincerely,

Signature of primary responsible party

Name of primary responsible party

cc: Names and addresses of all record fee title owners

ALAMEDA COUNTY  
HEALTH CARE SERVICES

AGENCY

DAVID J. KEARS, Agency Director



December 3, 1998

STID 3672

Ms. Karen Petryna  
Equiva Services LLC  
P.O. Box 6249  
Carson, CA 90749-6249

ENVIRONMENTAL HEALTH SERVICES

1131 Harbor Bay Parkway, Suite 250  
Alameda, CA 94502-6577  
(510) 567-6700  
(510) 337-9335 (FAX)

RE: Shell Station, 9750 Golf Links Road, Oakland

Dear Ms. Petryna:

I have reviewed the November 24, 1998 Cambria Environmental Technology, Inc. (Cambria) *Subsurface Investigation Report* for the limited assessment of an area adjacent to the northeastern-most dispenser at this site. This work was prompted by the elevated concentrations of fuel compounds detected in soil sampled during upgrade work performed on or adjacent to this dispenser.

The cited Cambria report presents the results of intrusive work performed in the area of the subject dispenser during July 1998. A single boring was advanced in two efforts to a reported depth of 30' below grade (BG). Up to 14,000 parts per million (ppm) total petroleum hydrocarbons as gasoline (TPH-G) and 100 ppm benzene were detected in soil at the 13' depth. This depth appears consistent with a silty sand layer reported between 12 and 15' BG. "Perched" water was reportedly encountered within this silty sand layer.

The extent and severity of this release has not yet been determined. Therefore, additional assessment work is required before consideration for case closure may be given.

At this time, and consistent with provisions of Article 11, Title 23, California Code of Regulations, please have your consultant submit a Soil and Water Investigation (SWI) work plan for the continued assessment of the fuel release at this site. The SWI work plan is due for submittal within 45 days of the date of this letter.

Please contact me at (510) 567-6783 should you have any questions.

Sincerely,

Scott O. Seery, CHMM  
Hazardous Materials Specialist

c: Mee Ling Tung, Director, Environmental Health  
Chuck Headlee, RWQCB  
Leroy Griffin, Oakland Fire Department



## FACSIMILE

To: Scott Seery  
Organization: Alameda County  
Environmental Health Services  
Fax #: 510-337-9335  
Re: Shell-branded Service Station  
9750 Golf Links Road, Oakland  
Hollow Stem Auger Boring  
Date: July 28, 1998  
Pages: 1, including this cover sheet.

Mr. Seery:

I am sending this facsimile to confirm our telephone conversation this morning. On July 6, 1998, Cambria advanced one Geoprobe soil boring (SB-1) at the site referenced above. The objective of this investigation was to define the vertical extent of hydrocarbons in soil. However, the Geoprobe encountered refusal before we were able to achieve vertical penetration. This is soil return to the surface. This refusal was due to limited access hollow-stem auger drill rig in order to complete boring SB-1.

We appreciate your continued assistance with this project. Please call me at (510) 420-3319 if you have any questions.

Thank You,

Maureen Feineman

cc: Karen Petryna, Equilon Enterprises LLC, (510) 237-7821

From the desk of...

Maureen D. Feineman  
Geologist  
Cambria Environmental Technology, Inc.  
1144 65th Street, Suite C  
Oakland, CA 94608

(510) 420-0700  
Fax: (510) 420-9170

ALAMEDA COUNTY  
HEALTH CARE SERVICES

AGENCY  
DAVID J. KEARS, Agency Director



ENVIRONMENTAL HEALTH SERVICES

1131 Harbor Bay Parkway, Suite 250  
Alameda, CA 94502-6577  
(510) 567-6700  
(510) 337-9335 (FAX)

July 2, 1998

STID 3672

Mr. Alex Perez  
Shell Oil Company  
P.O. Box 8080  
Martinez, CA 94553

RE: Shell Service Station, 9750 Golf Links Road, Oakland

Dear Mr. Perez:

I have taken over current management of this case from Pamela Evans of this office.

I recently completed review of the May 14, 1998 Cambria Environmental Technology, Inc. (Cambria) work plan entitled "*Investigation Work Plan*," and map revisions dated May 28 and July 2, 1998. This work plan and revisions are intended to corroborate the results of soil samples collected during the February 1998 dispenser upgrade activities.

The cited Cambria work plan is accepted as revised. I understand fieldwork is slated to begin July 6.

Please call me at (510) 567-6783 should you have any questions.

Sincerely,

Scott O. Seery, CHMM  
Hazardous Materials Specialist

cc: Mee Ling Tung, Director, Environmental Health  
Chuck Headlee, RWQCB  
Leroy Griffin, Oakland Fire Department  
Maureen Feineman, Cambria Environmental Technology, Inc.

# Alameda County Environmental Health

1131 Harbor Bay Pkwy., #250  
Alameda CA 94502-6577  
Telephone (510) 567-6700 FAX (510) 337-9335

## FACSIMILE COVER SHEET

TO: Maureen Feineman 420-9170

FROM: Scott SEERY

ACDEN

DATE: 6-5-98

Total number of pages including cover sheet 2

-NOTES- I went the site today. UST configuration /  
orientation are different than depicted on the  
location map. Will this, or should this, result  
in revision to the proposed boring location?  
Please call me (510/567-6783)  
Thanks!



Shell  
9750 Golf Links  
Oakland

6-5-98

ALAMEDA COUNTY  
HEALTH CARE SERVICES



AGENCY  
DAVID J. KEARS, Agency Director

April 10, 1998

Jeff Granberry  
Shell Oil Company  
P.O. Box 4023  
Concord CA 94520

ENVIRONMENTAL HEALTH SERVICES  
ENVIRONMENTAL PROTECTION  
1131 Harbor Bay Parkway, Suite 250  
Alameda, CA 94502-6577  
(510) 567-6700  
FAX (510) 337-9335

RE: **Fuel Contamination of Soil at Shell Station**  
**9750 Golf Links Road, Oakland CA 94605** (our site # 3672)

Dear Mr. Granberry:

In February 1998, soil samples were taken in the course of a tank system upgrade at the above referenced Shell station. Total petroleum hydrocarbons as gasoline were present at levels up to 7,800 ppm and benzene was present at up to 37 ppm in soil. These benzene levels exceed human health protective levels given in the Tier 1 Table of the ASTM Risk-Based Corrective Action Guidelines (E 1739-95).

At this time, additional investigation is required to define the extent and severity of the release. The investigation shall be in the form of a Soil and Water Investigation, or SWI. The information gathered through the SWI will be used to choose an appropriate course of action to remediate the site, if deemed necessary. The SWI must be done in accordance with the Regional Water Quality Control Board (RWQCB) Staff Recommendations for the Initial Evaluation and Investigation of Underground Tanks, and Article 11 of Title 23, California Code of Regulations. The major elements of the SWI are summarized in the enclosed Appendix A.

The SWI proposal is due **within 45 days** of the date of this letter (**by May 25, 1998**). Once the proposal is approved, field work should commence within 60 days. A report must be submitted within 45 days after the completion of this phase of work at the site. Subsequent reports are to be submitted quarterly until this site qualifies for RWQCB "sign off." All reports and proposals must be submitted under seal of a California Registered Geologist, Certified Engineering Geologist, or Registered Civil Engineer. **Please be advised that this is a formal request for technical reports pursuant to Title 23, CCR, Section 2722(c). Any extensions of the stated deadlines, or modifications of the required tasks, must be requested in writing and agreed to by this agency.**

Please contact me at (510) 567-6770 with any questions.

Sincerely,

Pamela J. Evans  
Senior Hazardous Materials Specialist

Enclosure  
Appendix A

c: **Dick Pantages, Alameda County Environmental Health Services** /files  
Alex Perez, Shell Oil Co.

Site re-opened

ALAMEDA COUNTY ENVIRONMENTAL HEALTH

# Transfer of Eligible Local Oversight Case

STID 3642 Date transferred NA 4/3/98

Date: 4-2-98 From: Pamela Evans

Site Name: Shell Service Station

Address: 9750 Golf Links Rd City: Oakland Zip: 94605

To be eligible for LOP, case must meet 3 qualifications:

1. Y  N Tanks Removed? # of removed? \_\_\_\_\_ Date removed: \_\_\_\_\_
2.  N Samples received? Contamination level: 7800 ppm  
Type of test TPH + 37 ppm benzene  
Contamination should be over 100 ppm TPH to qualify for LOP
3.  N Petroleum? Circle Type(s): • Avgas • leaded • unleaded • fuel oil • jet  
• diesel • waste oil • kerosene • solvents

Procedure to follow should your site meet all the above qualifications:

1.
  - a.  Close the deposit refund case. None
  - b.  Account for ALL time you have spent on the case.
  - c.  Turn in account sheet to Leslie Adams  
If there are funds still remaining it is still better to transfer the case to LOP as the rate for LOP allows more overhead. **DO NOT** attempt to continue to oversee the site simply because there are funds remaining!  
Remaining DepRef \$'s: \_\_\_\_\_  
DepRef Case Closed with Candyce/Leslie? Y N (If no, explain why below.)
2. Submit the completed A and B permit application forms to **NORMA**.  
None - this was associated with a pipe upgrade overseen by City of Oakland
3. Give the entire case to the proper LOP staff.

Ro# 2441 DH

File Alco

UNDERGROUND STORAGE TANK UNAUTHORIZED RELEASE (LEAK) / CONTAMINATION SITE REPORT			
EMERGENCY <input type="checkbox"/> YES <input checked="" type="checkbox"/> NO		HAS STATE OFFICE OF EMERGENCY SERVICES REPORT BEEN FILED? <input type="checkbox"/> YES <input checked="" type="checkbox"/> NO	
REPORT DATE 01/21/2009		CASE #	
FOR LOCAL AGENCY USE ONLY I HEREBY CERTIFY THAT I HAVE DISTRIBUTED THIS INFORMATION ACCORDING TO THE DISTRIBUTION SHOWN ON THE INSTRUCTION SHEET ON THE BACK PAGE OF THIS FORM. <i>Alameda County</i>			
REPORTED BY	NAME OF INDIVIDUAL FILING REPORT Hector E. Perez		PHONE (510) 335-5027
	SIGNATURE <i>Hector E. Perez</i>		DATE
	REPRESENTING <input type="checkbox"/> LOCAL AGENCY <input checked="" type="checkbox"/> OWNER/OPERATOR <input type="checkbox"/> REGIONAL BOARD <input type="checkbox"/> OTHER		
COMPANY OR AGENCY NAME Shell Oil Products Company			
ADDRESS PO Box 8080 Martinez CA 94553			
RESPONSIBLE PARTY	NAME Shell Oil Products Company		PHONE (510) 335-5027
	CONTACT PERSON Alex Perez		ADDRESS PO Box 8080 Martinez CA 94553
SITE LOCATION	FACILITY NAME (IF APPLICABLE) Shell Service Station		OPERATOR
	ADDRESS 9750 Golf Links Road Oakland Alameda 94605		PHONE (510) 562-5616
	CROSS STREET Mountain Boulevard		
IMPLEMENTING AGENCIES	LOCAL AGENCY AGENCY NAME Alameda County Dept. of Env. Health		CONTACT PERSON Thomas Peacock
	REGIONAL BOARD San Francisco Bay		PHONE (510) 567-6782
SUBSTANCES INVOLVED	(1) NAME Petroleum Fuel		QUANTITY LOST (GALLONS) 7 <input checked="" type="checkbox"/> UNKNOWN
	(2)		<input type="checkbox"/> UNKNOWN
DISCOVERY/ABATEMENT	DATE DISCOVERED 01/21/09		HOW DISCOVERED <input type="checkbox"/> INVENTORY CONTROL <input type="checkbox"/> SUBSURFACE MONITORING <input type="checkbox"/> NUISANCE CONDITIONS <input type="checkbox"/> TANK TEST <input type="checkbox"/> TANK REMOVAL <input checked="" type="checkbox"/> OTHER <i>Dispenser Upgrade</i>
	DATE DISCHARGE BEGAN <input checked="" type="checkbox"/> UNKNOWN		METHOD USED TO STOP DISCHARGE (CHECK ALL THAT APPLY) <input type="checkbox"/> REMOVE CONTENTS <input type="checkbox"/> CLOSE TANK & REMOVE <input type="checkbox"/> REPAIR PIPING <input type="checkbox"/> REPAIR TANK <input type="checkbox"/> CLOSE TANK & FILL IN PLACE <input type="checkbox"/> CHANGE PROCEDURE <input type="checkbox"/> REPLACE TANK <input checked="" type="checkbox"/> OTHER <i>Dispenser Upgrade</i>
	HAS DISCHARGE BEEN STOPPED? <input checked="" type="checkbox"/> YES <input type="checkbox"/> NO IF YES, DATE 01/20/09		
SOURCE/CAUSE	SOURCE OF DISCHARGE <input type="checkbox"/> TANK LEAK <input type="checkbox"/> UNKNOWN <input type="checkbox"/> OVERFILL <input type="checkbox"/> RUPTURE/FAILURE <input type="checkbox"/> SPILL <input type="checkbox"/> PIPING LEAK <input checked="" type="checkbox"/> OTHER <i>Dispenser</i> <input type="checkbox"/> CORROSION <input checked="" type="checkbox"/> UNKNOWN <input type="checkbox"/> OTHER		CAUSE(S)
	CHECK ONE ONLY <input checked="" type="checkbox"/> UNDETERMINED <input type="checkbox"/> SOIL ONLY <input type="checkbox"/> GROUNDWATER <input type="checkbox"/> DRINKING WATER - (CHECK ONLY IF WATER WELLS HAVE ACTUALLY BEEN AFFECTED)		
CURRENT STATUS	CHECK ONE ONLY <input checked="" type="checkbox"/> NO ACTION TAKEN <input type="checkbox"/> PRELIMINARY SITE ASSESSMENT WORKPLAN SUBMITTED <input type="checkbox"/> POLLUTION CHARACTERIZATION <input type="checkbox"/> LEAK BEING CONFIRMED <input type="checkbox"/> PRELIMINARY SITE ASSESSMENT UNDERWAY <input type="checkbox"/> POST CLEANUP MONITORING IN PROGRESS <input type="checkbox"/> REMEDIATION PLAN <input type="checkbox"/> CASE CLOSED (CLEANUP COMPLETED OR UNNECESSARY) <input type="checkbox"/> CLEANUP UNDERWAY		
	REMEDIAL ACTION CHECK APPROPRIATE ACTION(S) (SEE BACK FOR DETAILS) <input type="checkbox"/> EXCAVATE & DISPOSE (ED) <input type="checkbox"/> REMOVE FREE PRODUCT (FP) <input type="checkbox"/> ENHANCED BIO DEGRADATION (IT) <input type="checkbox"/> CAP SITE (CD) <input type="checkbox"/> EXCAVATE & TREAT (ET) <input type="checkbox"/> PUMP & TREAT GROUNDWATER (GT) <input type="checkbox"/> REPLACE SUPPLY (RS) <input type="checkbox"/> CONTAINMENT BARRIER (CB) <input checked="" type="checkbox"/> NO ACTION REQUIRED (NA) <input type="checkbox"/> TREATMENT AT HOOKUP (HU) <input type="checkbox"/> VENT SOIL (VS) <input type="checkbox"/> VACUUM EXTRACT (VE) <input type="checkbox"/> OTHER (OT)		
COMMENTS			

# UNDERGROUND STORAGE TANK UNAUTHORIZED RELEASE (LEAK) / CONTAMINATION SITE REPORT

EMERGENCY <input type="checkbox"/> YES <input checked="" type="checkbox"/> NO		HAS STATE OFFICE OF EMERGENCY SERVICES REPORT BEEN FILED? <input type="checkbox"/> YES <input checked="" type="checkbox"/> NO		FOR LOCAL AGENCY USE ONLY I HEREBY CERTIFY THAT I HAVE DISTRIBUTED THIS INFORMATION ACCORDING TO THE DISTRIBUTION SHOWN ON THE INSTRUCTION SHEET ON THE BACK PAGE OF THIS FORM.	
REPORT DATE 01/22/2009		CASE #		SIGNED: <i>Patricia Stevens</i> DATE:	
REPORTED BY	NAME OF INDIVIDUAL FILING REPORT Alejandro E. Perez		PHONE (510) 335-5027		SIGNATURE <i>Alejandro Perez</i>
	REPRESENTING <input type="checkbox"/> LOCAL AGENCY <input checked="" type="checkbox"/> OWNER/OPERATOR <input type="checkbox"/> REGIONAL BOARD <input type="checkbox"/> OTHER		COMPANY OR AGENCY NAME Shell Oil Products Company		
	ADDRESS PO Box 8080 Martinez CA 94553				
RESPONSIBLE PARTY	NAME Shell Oil Products Company		CONTACT PERSON Alex Perez		PHONE (510) 335-5027
	ADDRESS PO Box 8080 Martinez CA 94553				
SITE LOCATION	FACILITY NAME (IF APPLICABLE) Shell Service Station		OPERATOR		PHONE (510) 562-5616
	ADDRESS 9750 Golf Links Road		Oakland		Alameda 94605
	CROSS STREET Mountain Boulevard				
IMPLEMENTING AGENCIES	LOCAL AGENCY Alameda County Dept. of Env. Health		CONTACT PERSON Thomas Peacock		PHONE (510) 567-6782
	REGIONAL BOARD San Francisco Bay		Steven Hill		PHONE (510) 286-1255
SUBSTANCES INVOLVED	(1) NAME Petroleum Fuel			QUANTITY LOST (GALLONS) <input checked="" type="checkbox"/> UNKNOWN	
	(2) _____ <input type="checkbox"/> UNKNOWN				
DISCOVERY/ABATEMENT	DATE DISCOVERED 01/21/2009		HOW DISCOVERED <input type="checkbox"/> INVENTORY CONTROL <input type="checkbox"/> SUBSURFACE MONITORING <input type="checkbox"/> NUISANCE CONDITIONS <input type="checkbox"/> TANK TEST <input type="checkbox"/> TANK REMOVAL <input checked="" type="checkbox"/> OTHER <i>Dispenser Upgrade</i>		
	DATE DISCHARGE BEGAN <input checked="" type="checkbox"/> UNKNOWN		METHOD USED TO STOP DISCHARGE (CHECK ALL THAT APPLY) <input type="checkbox"/> REMOVE CONTENTS <input type="checkbox"/> CLOSE TANK & REMOVE <input type="checkbox"/> REPAIR PIPING <input type="checkbox"/> REPAIR TANK <input type="checkbox"/> CLOSE TANK & FILL IN PLACE <input type="checkbox"/> CHANGE PROCEDURE <input type="checkbox"/> REPLACE TANK <input checked="" type="checkbox"/> OTHER <i>Dispenser Upgrade</i>		
	HAS DISCHARGE BEEN STOPPED? <input checked="" type="checkbox"/> YES <input type="checkbox"/> NO IF YES, DATE 01/20/09				
SOURCE/CAUSE	SOURCE OF DISCHARGE <input type="checkbox"/> TANK LEAK <input type="checkbox"/> UNKNOWN <input type="checkbox"/> OVERFILL <input type="checkbox"/> RUPTURE/FAILURE <input type="checkbox"/> SPILL <input type="checkbox"/> PIPING LEAK <input checked="" type="checkbox"/> OTHER <i>Dispenser</i> <input type="checkbox"/> CORROSION <input checked="" type="checkbox"/> UNKNOWN <input type="checkbox"/> OTHER		CAUSE(S)		
	CHECK ONE ONLY <input checked="" type="checkbox"/> UNDETERMINED <input type="checkbox"/> SOIL ONLY <input type="checkbox"/> GROUNDWATER <input type="checkbox"/> DRINKING WATER - (CHECK ONLY IF WATER WELLS HAVE ACTUALLY BEEN AFFECTED)				
CURRENT STATUS	CHECK ONE ONLY <input checked="" type="checkbox"/> NO ACTION TAKEN <input type="checkbox"/> PRELIMINARY SITE ASSESSMENT WORKPLAN SUBMITTED <input type="checkbox"/> POLLUTION CHARACTERIZATION <input type="checkbox"/> LEAK BEING CONFIRMED <input type="checkbox"/> PRELIMINARY SITE ASSESSMENT UNDERWAY <input type="checkbox"/> POST CLEANUP MONITORING IN PROGRESS <input type="checkbox"/> REMEDIATION PLAN <input type="checkbox"/> CASE CLOSED (CLEANUP COMPLETED OR UNNECESSARY) <input type="checkbox"/> CLEANUP UNDERWAY				
	CHECK APPROPRIATE ACTION(S) (SEE BACK FOR DETAILS) <input type="checkbox"/> EXCAVATE & DISPOSE (ED) <input type="checkbox"/> REMOVE FREE PRODUCT (FP) <input type="checkbox"/> ENHANCED BIO DEGRADATION (IT) <input type="checkbox"/> CAP SITE (CD) <input type="checkbox"/> EXCAVATE & TREAT (ET) <input type="checkbox"/> PUMP & TREAT GROUNDWATER (GT) <input type="checkbox"/> REPLACE SUPPLY (RS) <input type="checkbox"/> CONTAINMENT BARRIER (CB) <input checked="" type="checkbox"/> NO ACTION REQUIRED (NA) <input type="checkbox"/> TREATMENT AT HOOKUP (HU) <input type="checkbox"/> VENT SOIL (VS) <input type="checkbox"/> VACUUM EXTRACT (VE) <input type="checkbox"/> OTHER (OT)				
COMMENTS	98 FEB 26 PM 2:55				



ALAMEDA COUNTY  
HEALTH CARE SERVICES

AGENCY

DAVID J. KEARS, Agency Director



RAFAT A. SHAHID, DIRECTOR

October 31, 1995

Mr. Dan Kirk  
Shell Oil Company  
P.O. Box 4023  
Concord, CA 94520

DEPARTMENT OF ENVIRONMENTAL HEALTH  
1131 Harbor Bay Parkway  
Alameda, CA 94502-6577  
(510) 567-8777

STID 3672

Re: Subsurface Investigation Workplan Addendum for Shell  
Service Station WIC #204-5508-2808, located at 9750 Golf  
Links Road, Oakland, California

Dear Mr. Kirk,

This office has reviewed over Weiss Associates' Subsurface Investigation Workplan Addendum, dated October 24, 1995, for the above site. To iterate the meaning of Section 66261.24 (a)(2)(A), Chapter 11, Division 4.5, Title 22 California Code of Regulations, if the TCLP analysis result is less than 5 mg/l and the STLC result is less than 560 mg/l, the concentrations of chromium in soil would not be considered a threat to groundwater. However, if you have STLC results exceeding 560 mg/l, the chromium concentrations would be considered non-RCRA hazardous waste (i.e., California hazardous waste).

If elevated contaminant levels are identified in the soil or groundwater in the proposed phase of work, additional investigations may be required.

Field work shall commence within 45 days after the date of this letter. A report documenting the work shall be submitted to this office within 45 days after completing field activities.

If you have any questions or comments, please contact me at (510) 567-6763.

Sincerely,

  
Juliet Shin  
Senior Hazardous Materials Specialist

cc: Tim R. Utterback  
Weiss Associates  
5500 Shellmound St.  
Emeryville, CA 94608-2411

Acting Chief-File

ALAMEDA COUNTY  
HEALTH CARE SERVICES

AGENCY

DAVID J. KEARS, Agency Director



RAFAT A. SHAHID, DIRECTOR

September 28, 1995

Mr. Dan Kirk  
Shell Oil Company  
P.O. Box 4023  
Concord, CA 94520

DEPARTMENT OF ENVIRONMENTAL HEALTH

1131 Harbor Bay Parkway  
Alameda, CA 94502-6577  
(510) 567-6777

STID 3672

Re: Work plan for investigations at Shell Service Station WIC #204-5508-2808, located at 9750 Golf Links Road, Oakland, California

Dear Mr. Kirk,

This office has reviewed Weiss Associates' Subsurface Investigation and Site Closure Workplan, dated September 18, 1995, for the above site. This work plan is acceptable to this office with the following additional requirements:

- o The work plan states that no further analysis for chromium needs to be conducted, based on Section 66261.24(a)(2)(A), Chapter 11, Division 4.5, Title 22, California Code of Regulations. However, in order for this Section of Title 22 to apply to this site, both a TCLP and WET (STLC) analysis needs to be conducted for chromium, which have not yet been conducted at the site. If a TCLP analysis is not conducted, than the California default value to be utilized would be the 5 mg/l value listed in Table II, Section 66261.24(a)(2)(A). Based on the fact that a TCLP analysis for chromium has not yet been conducted at the site, and the level of chromium in the site soil has exceeded ten times the STLC of 5 mg/l, this office is requesting that the future groundwater sample(s) be analyzed for dissolved chromium, as well as Oil & Grease, TPHg, TPHd, and BTEX.
- o What references were used to obtain the "assumed" groundwater gradient direction? Please provide this office with the references or more explanation as to why the groundwater is most likely flowing to the west.

Please submit an addendum to the work plan, addressing the above concerns, within 30 days of the date of this letter.

If you have any questions or comments, please contact me at (510) 567-6763.

Mr. Dan Kirk  
Re: 9750 Golf Links Rd.  
September 28, 1995  
Page 2 of 2

Sincerely,

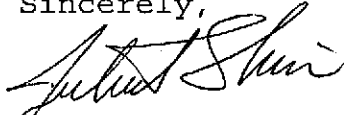

Juliet Shin  
Senior Hazardous Materials Specialist

cc: Tim R. Utterback  
Weiss Associates  
5500 Shellmound St.  
Emeryville, CA 94608-2411

Peter McKereghan  
Weiss Associates  
5500 Shellmound St.  
Emeryville, CA 94608-2411

Acting Chief-File

ALAMEDA COUNTY  
HEALTH CARE SERVICES



AGENCY

DAVID J. KEARS, Agency Director

RAFAT A. SHAHID, Assistant Agency Director

August 8, 1995

Mr. Dan Kirk  
Shell Oil Company  
P.O. Box 4023  
Concord, CA 94520

Alameda County  
Environmental Protection Division  
1131 Harbor Bay Parkway, Room 250  
Alameda CA 94502-6577

CC4586

Re: Investigations at Shell Service Station WIC #204-5508-2808,  
located at 9750 Golf Links Road, Oakland, California

Dear Mr. Kirk,

This office has reviewed Weiss Associate's (Weiss) Tank Removal Closure Report, dated July 6, 1995, for the above site. Per the report, a 550-gallon waste oil tank was removed from the site on March 7, 1995. Per Alameda County's inspection report, several holes, up to 1/2-inch in diameter, were noted on the sides, bottom, and top of the tank. Additionally, stained soils and strong odors were noted down to at least 9-feet below ground surface (bgs) in the tank pit. The results of the initial soil sample, collected from beneath the tank at 7-feet bgs, identified up to 12,000 parts per million (ppm) Oil & Grease, 3,900 ppm TPH as diesel, 190 ppm TPH as gasoline, and 0.43 ppm toluene. After overexcavation down to 11-feet bgs, upto 62 ppm Oil & Grease and 0.083 ppm toluene were identified in a confirmatory soil sample.

Based on the above information, you are required to conduct investigations at the site to confirm that groundwater has not been impacted. You will be required to analyze future samples for Oil & Grease, TPH as gasoline and diesel, BTEX, and PCBs. Additionally, based on the fact that soil samples collected from the former tank pit identified levels of chromium exceeding ten times the STLC, you will be required to analyze future samples for heavy metals.

Although the report states that a total of 75 cubic yards of soil was hauled off site, this office has not yet received copies of the manifests that document this disposal. Please submit these manifests within 30 days of the date of this letter.

A work plan addressing groundwater investigations at the site shall be submitted to this office within 45 days of the date of this letter.

If you have any questions or comments, please contact me at (510) 567-6763.

Mr. Dan Kirk  
Re: 9750 Golf Links Rd.  
August 8, 1995  
Page 2 of 2

Sincerely,

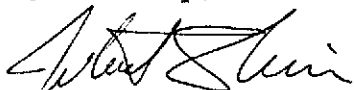

Juliet Shin  
Senior Hazardous Materials Specialist

cc: Tim R. Utterback  
Weiss Associates  
5500 Shellmound St.  
Emeryville, CA 94608-2411

Acting Chief-File



July 31, 1995

Eva Chu  
Alameda County Health Agency  
Department of Environmental Health  
1131 Harbor Bay Parkway, Second Floor  
Alameda, California 94502

**Re: Second Quarter 1995  
Shell Service Station  
WIC #204-5508-2808  
9570 Golf Links Road  
Oakland, California  
WA Job #81-1055-105**

Dear Self-Directed Case Advisor:

On behalf of Shell Oil Products Company, Weiss Associates (WA) has prepared this status report to satisfy the quarterly reporting requirements prescribed by California Administrative Code Title 23 Waters, Division 3, Chapter 16, Article 5, Section 2652.d. No characterization or abatement was conducted or requested for this site this quarter. WA will continue to submit quarterly updates to your agency. I trust this submittal meets your needs. Please call me if you have any questions.

Sincerely,  
Weiss Associates

Tim Utterback  
Staff Engineer

cc: Dan Kirk, Shell Oil Products Company, PO Box 4023, Concord, California 94524

TRU/:tru  
J:\SHELL\OPTICALWATER.DOC

# DISPOSAL CONFIRMATION

Consultant: WEISS ASSOCIATES  
 Contact: FAITH DAVERIN  
 Phone/Fax: (510) 547-5420/FAX (510) 547-5043  
 Client: SHELL  
 Station #/Wic #: WIC #204-5508-2808  
 Site Address: 9570 GOLF LINKS ROAD  
 City/State: OAKLAND, CA  
 Estimated YD/Ton: 25 YARDS  
 Actual YD/Ton: 42.89 TONS → 60 yds.  
 Disposal Facility: FORWARD, INC.  
 Disposal Date: ~~12/02/94~~ 5/19/95  
 Contact: MARK HAYES  
 Phone #: (415) 892-2851  
 Hauler: MANLEY & SONS TRUCKING, INC.  
 Contact: TIM A. MANLEY  
 Phone #: (916) 381-6864  
 Fax #: (916) 381-1573

Date & Time Faxed

5/31/95

8:00am

DATE:

TO : Local Oversight Program

FROM:

SUBJ: Transfer of Eligible Oversight Case

Site name: M and S SHELL

Address: 9750 Golf Links Rd city Oak zip 94605

Closure plan attached?  Y  N DepRef remaining \$ 239.50

DepRef Project # 468 STID #(if any) 3672

Number of Tanks: \_\_\_\_\_ removed?  Y  N Date of removal \_\_\_\_\_

Leak Report filed?  Y  N Date of Discovery \_\_\_\_\_

Samples received?  Y  N Contamination: \_\_\_\_\_

Petroleum  Y  N Types: Avgas Jet leaded unleaded Diesel  
fuel oil waste oil kerosene solvents

Monitoring wells on site \_\_\_\_\_ Monitoring schedule?  Y  N

LUFT category 1 2 3 \* H S C A R W G O

Briefly describe the following:

Preliminary Assessment \_\_\_\_\_

Remedial Action \_\_\_\_\_

Post Remedial Action Monitoring \_\_\_\_\_

Enforcement Action \_\_\_\_\_

*Any work done on it? Any tanks removed?*



# UNDERGROUND STORAGE TANK UNAUTHORIZED RELEASE (LEAK) / CONTAMINATION SITE REPORT

EMERGENCY <input type="checkbox"/> YES <input checked="" type="checkbox"/> NO		HAS STATE OFFICE OF EMERGENCY SERVICES REPORT BEEN FILED? <input type="checkbox"/> YES <input checked="" type="checkbox"/> NO		FOR LOCAL AGENCY USE ONLY I HEREBY CERTIFY THAT I HAVE DISTRIBUTED THIS INFORMATION ACCORDING TO THE DISTRIBUTION SHOWN ON THE INSTRUCTION SHEET ON THE BACK PAGE OF THIS FORM.	
REPORT DATE 03/23/95		CASE #		SIGNED: <i>[Signature]</i> DATE: 3/28/95	
REPORTED BY	NAME OF INDIVIDUAL FILING REPORT Karen D. Clark HS&E Analyst		PHONE (510) 675-6114	SIGNATURE <i>[Signature]</i>	
	REPRESENTING <input checked="" type="checkbox"/> OWNER/OPERATOR <input type="checkbox"/> REGIONAL BOARD <input type="checkbox"/> LOCAL AGENCY <input type="checkbox"/> OTHER		COMPANY OR AGENCY NAME Shell Oil Company		
	ADDRESS 1390 WILLOW PASSRD., STE 900 CONCORD CA 94521				
RESPONSIBLE PARTY	NAME SHELL OIL COMPANY <input type="checkbox"/> UNKNOWN		CONTACT PERSON JEFF BYRAM	PHONE (510) 675-6146	
	ADDRESS 1390 WILLOW PASS RD., STE 900 Concord CA 94521				
SITE LOCATION	FACILITY NAME (IF APPLICABLE) M&S Shell		OPERATOR Mohammad Kamal Mashhoon	PHONE (510) 562-5616	
	ADDRESS 9750 Golf Links Rd Oakland Alameda 94605				
	CROSS STREET I-580 West Freeway				
IMPLEMENTING AGENCIES	LOCAL AGENCY AGENCY NAME Alameda Co., Health Care Agency		CONTACT PERSON Eva Chu	PHONE 510 567-6762	
	REGIONAL BOARD San Francisco Bay		CONTACT PERSON Kevin Graves	PHONE 510 286-1755	
SUBSTANCES INVOLVED	(1) NAME Waste Oil		QUANTITY LOST (GALLONS) <input checked="" type="checkbox"/> UNKNOWN		
	(2)		<input type="checkbox"/> UNKNOWN		
DISCOVERY/ABATEMENT	DATE DISCOVERED 03/23/95		HOW DISCOVERED <input type="checkbox"/> INVENTORY CONTROL <input type="checkbox"/> SUBSURFACE MONITORING <input type="checkbox"/> NUISANCE CONDITIONS <input type="checkbox"/> TANK TEST <input checked="" type="checkbox"/> TANK REMOVAL <input type="checkbox"/> OTHER		
	DATE DISCHARGE BEGAN <input checked="" type="checkbox"/> UNKNOWN		METHOD USED TO STOP DISCHARGE (CHECK ALL THAT APPLY) <input type="checkbox"/> REMOVE CONTENTS <input checked="" type="checkbox"/> CLOSE TANK & REMOVE <input type="checkbox"/> REPAIR PIPING <input type="checkbox"/> REPAIR TANK <input type="checkbox"/> CLOSE TANK & FILL IN PLACE <input type="checkbox"/> CHANGE PROCEDURE <input type="checkbox"/> REPLACE TANK <input type="checkbox"/> OTHER		
	HAS DISCHARGE BEEN STOPPED? <input checked="" type="checkbox"/> YES <input type="checkbox"/> NO IF YES, DATE				
SOURCE/ CAUSE	SOURCE OF DISCHARGE <input type="checkbox"/> TANK LEAK <input checked="" type="checkbox"/> UNKNOWN <input type="checkbox"/> PIPING LEAK <input type="checkbox"/> OTHER		CAUSE(S) <input type="checkbox"/> OVERFILL <input type="checkbox"/> RUPTURE/FAILURE <input type="checkbox"/> SPILL <input type="checkbox"/> CORROSION <input type="checkbox"/> UNKNOWN <input type="checkbox"/> OTHER		
	CASE TYPE CHECK ONE ONLY <input type="checkbox"/> UNDETERMINED <input checked="" type="checkbox"/> SOIL ONLY <input type="checkbox"/> GROUNDWATER <input type="checkbox"/> DRINKING WATER - (CHECK ONLY IF WATER WELLS HAVE ACTUALLY BEEN AFFECTED)				
CURRENT STATUS	CHECK ONE ONLY <input type="checkbox"/> NO ACTION TAKEN <input type="checkbox"/> PRELIMINARY SITE ASSESSMENT WORKPLAN SUBMITTED <input type="checkbox"/> POLLUTION CHARACTERIZATION <input type="checkbox"/> LEAK BEING CONFIRMED <input type="checkbox"/> PRELIMINARY SITE ASSESSMENT UNDERWAY <input type="checkbox"/> POST CLEANUP MONITORING IN PROGRESS <input type="checkbox"/> REMEDIATION PLAN <input checked="" type="checkbox"/> CASE CLOSED (CLEANUP COMPLETED OR UNNECESSARY) <input type="checkbox"/> CLEANUP UNDERWAY				
	REMEDIAL ACTION CHECK APPROPRIATE ACTION(S) (SEE BACK FOR DETAILS) <input checked="" type="checkbox"/> EXCAVATE & DISPOSE (ED) <input type="checkbox"/> REMOVE FREE PRODUCT (FP) <input type="checkbox"/> ENHANCED BIO DEGRADATION (IT) <input type="checkbox"/> CAP SITE (CD) <input type="checkbox"/> EXCAVATE & TREAT (ET) <input type="checkbox"/> PUMP & TREAT GROUNDWATER (GT) <input type="checkbox"/> REPLACE SUPPLY (RS) <input type="checkbox"/> CONTAINMENT BARRIER (CB) <input type="checkbox"/> NO ACTION REQUIRED (NA) <input type="checkbox"/> TREATMENT AT HOOKUP (HU) <input type="checkbox"/> VENT SOIL (VS) <input type="checkbox"/> VACUUM EXTRACT (VE) <input type="checkbox"/> OTHER (OT)				
COMMENTS	Release confirmed by <del>soil</del> <del>soil</del> samples <del>indicated</del> test results. Tank removed				
	all impacted soil was excavated by Weiss Associates, Shell's Consultants.				

ENVIRONMENTAL PROTECTION Shell Oil Company



95 MAR 28 PM 1:17

P O Box 4023  
Concord CA 94524

East Bay Retail Marketing District

1390 Willow Pass Road  
Suite 900  
Concord CA 94520

March 27, 1995

CERTIFIED  
RETURN RECEIPT REQUESTED

Eva Chu, Haz Mat'l Inspector  
Alameda Co., Health Care Services  
1131 Harbor Bay Pkwy Room 250  
Alameda, CA 94502-6577

SUBJECT: INCIDENT ON 03/23/95 FOR SHELL STATION AT 9750 GOLF LINK RD  
OAKLAND, CA 94605

Dear Eva:

Enclosed please find an Underground Storage Tank Unauthorized Release Contamination Site Report for the above location. Also, enclosed is Shell's UGST Financial Responsibility Document. *→ filed w/ Generator File*

Source of discharge was discovered on 3/21/95 per soil samples test results. Waste Oil tank and all impacted soil was excavated and disposed by Shell's Consultant, Weiss Associates.

For our records, please sign the Acknowledgement of Receipt below. Send a copy of the signed letter and future information to my attention at the above address.

If you have any questions, please contact Jeff Byram at 510 675-146.

Very truly yours,

Karen D. Clark  
HS&E Analyst Admin Support

Enclosure(s)

cc: w/o encls: HS&E Repr. - J. B. Koch

ACKNOWLEDGEMENT OF RECEIPT

*[Signature]*  
SIGNATURE  
*Haz Mat Specialist*  
TITLE  
*3/28/95*  
DATE

FORM5

Note: Future correspondence should be to  
Ms. Juliet Shin, Sr. Haz Mat Specialist

white -env. health  
yellow -facility  
pink -files

ALAMEDA COUNTY, DEPARTMENT OF ENVIRONMENTAL HEALTH  
Hazardous Materials Inspection Form

1131 Harbor Bay Pkwy  
Alameda CA 94502  
510/567-6700

II, III

Site ID # \_\_\_\_\_ Site Name Shell Oil Today's Date 3/7/95  
Site Address 9750 Golf Links Rd  
City Oakland Zip 94605 Phone \_\_\_\_\_

\_\_\_\_ MAX AMT stored > 500 lbs, 55 gal., 200 cft.?  
**Inspection Categories:**  
\_\_\_\_ I. Haz. Mat/Waste GENERATOR/TRANSPORTER  
\_\_\_\_ II. Hazardous Materials Business Plan, Acutely Hazardous Materials  
 III. Under ground Storage Tanks w.o. JST Removal

\* Calif. Administration Code (CAC) or the Health & Safety Code (HS&C)

**Comments:**

0 % HCL                      20 % O<sub>2</sub>  
~ 250 gal oil + water pumped by overgreen

500 gal w.o. tank  
Severe pitting and Rust - several through holes - up to 1/2" diameter holes on sides, bottom + top of tank

ⓐ Soil sample collected a ~ 7.0' depth blue green stained w/ <sup>sandy clay</sup> strong odor

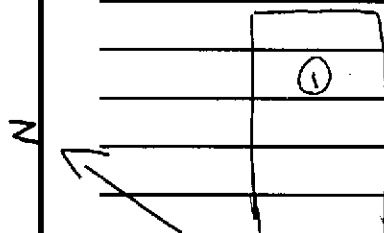

Analyze for TPH-G, TPH-D, BTEX, TOG, metals (Cd, Cr, Pb, Ni, Zn), Cl-HCs, and semi volatiles

At 8' - still stained sandy clay w/ mod. odor  
At 9' - still stained, but more sand content still mod - strong odor

Also analyze for semi volatile compounds (8270)

Contact \_\_\_\_\_  
Title \_\_\_\_\_  
Signature [Signature]

Inspector Eva CHW  
Signature [Signature]

II, III

white - env. health  
yellow - facility  
pink - files

# ALAMEDA COUNTY, DEPARTMENT OF ENVIRONMENTAL HEALTH

1131 Harbor Bay Pkwy  
Alameda CA 94502  
510/567-6700

## Hazardous Materials Inspection Form

II, III

Site ID # \_\_\_\_\_ Site Name Shell Oil Today's Date 2/7/95  
Site Address 9750 Golf Links Rd  
City Oakland Zip 94605 Phone \_\_\_\_\_

\_\_\_\_ MAX AMT stored > 500 lbs, 55 gal., 200 cft.?  
**Inspection Categories:**  
\_\_\_\_ I. Haz. Mat/Waste GENERATOR/TRANSPORTER  
\_\_\_\_ II. Hazardous Materials Business Plan, Acutely Hazardous Materials  
 III. Under ground Storage Tanks was not removed

\* Calif. Administration Code (CAC) or the Health & Safety Code (HS&C)

**Comments:**  
Oil spill 20 9 0.  
~ 250 gal oil + water pumped by our crew  
in 500 gal w.d. tank  
some getting out Rust - several through tubes - up to 2"  
diameter holes in sides, bottom + top of tank  
Ⓢ Soil sample collected at ~ 7.0' depth blue green sludge w/ sandy clay  
sh, adax

①  
Analysis for Toluene, Toluene-D, BTEX, Toluene, naphthalene (Cd, Cr, Pb, Ni, Zn), CHLOR, and heavy metals  
At 8' - still sludgy sandy clay w/ sand  
At 9' - still sludgy but more sand content still mud - sandy clay  
Also analyze for semi-volatile compounds (270)

II, III

Contact \_\_\_\_\_  
Title \_\_\_\_\_  
Signature [Signature]

Inspector [Signature]  
Signature \_\_\_\_\_

*Subject Shell 2/22/95*  
*Subject Shell*  
 Please comply w/ additional comments in red ink. Please notify this office at least 48 hours prior to tank removal activity.

400  
 RECEIVED  
 SEP 15 10 14 27

ALAMEDA COUNTY HEALTH CARE SERVICES AGENCY  
 DEPARTMENT OF ENVIRONMENTAL HEALTH  
 HAZARDOUS MATERIALS DIVISION  
 1131 HARBOR BAY PARKWAY, STE 250  
 ALAMEDA, CA. 94502-6577  
 PHONE NO. 510/567-6700  
 FAX 510 337-9335

**ACCEPTED**  
 DEPARTMENT OF ENVIRONMENTAL HEALTH  
 470 - 27th Street, Third Floor  
 Oakland, CA 94612  
 Telephone: (415) 874-2417

These plans have been reviewed and found to be acceptable and essentially meet the requirements of State and local health laws. Changes to your plans indicated by the Department are to assure compliance with State and local laws. The project described herein is now released for release of any required building permits or construction.

One copy of these accepted plans must be on the job site available to all contractors and craftsmen involved with the removal.

As a change or alteration of these plans or specifications must be submitted to the Department and to the Fire and Building Inspection Department to determine if such changes meet the requirements of State and local laws. Notify Risk Reduction at least 48 hours prior to the following required notification:

- \_\_\_\_\_ Removal of Tank and Piping
- \_\_\_\_\_ Sampling
- \_\_\_\_\_ Final Inspection

Receipt of a permit to operate is dependent on compliance with accepted plans and all applicable laws and regulations.

**UNDERGROUND TANK CLOSURE PLAN**

\* \* \* Complete according to attached instructions \* \* \*

1. Business Name SHELL OIL COMPANY  
 Business Owner SHELL OIL COMPANY
  2. Site Address 9750 GOLF LINKS ROAD  
 City OAKLAND Zip 94605 Phone 510/562-5616
  3. Mailing Address P.O. BOX 4023  
 City CONCORD Zip 94520 Phone 510/675-6145
  4. Land Owner SHELL OIL COMPANY  
 Address P.O. BOX 4023 City, State CA. Zip 94520
  5. Generator name under which tank will be manifested \_\_\_\_\_  
SHELL OIL COMPANY
- EPA I.D. No. under which tank will be manifested CAD981403108

# PARADISO MECHANICAL, INC.

## GENERAL & PETROLEUM CONTRACTORS and ENVIRONMENTAL SERVICES

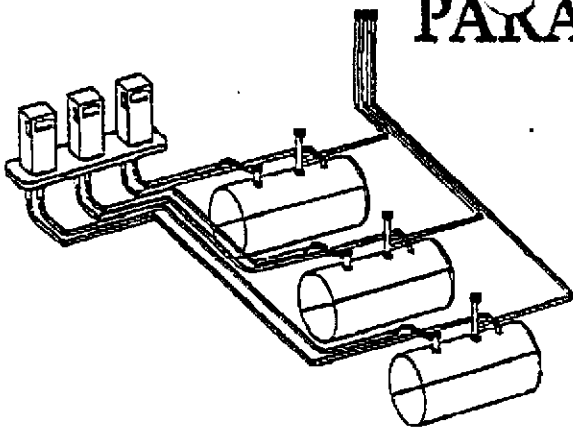

P.O. BOX 1836  
2800 WILLIAMS STREET  
SAN LEANDRO, CA 94577

LICENSE NO. 677909  
PHONE (510) 614-8390  
FAX (510) 614-8396

### FAX COVER SHEET

PARADISO FAX NUMBER 510-614-8396

DATE: 2/27/95

NUMBER OF PAGES INCLUDING COVER SHEET: 2

TO: Ala Co. Health ATTENTION: J. Shinn

FAX NUMBER: 510 337-9335

FROM: Linda Martin

SUBJECT: 9750 Golf Link Rd.

REMARK: Revised page <sup>3</sup> 2 for permit application.

\* I neglected to update this info when Shell  
changed consultant.

PLEASE CALL OUR OFFICE IF YOU DO NOT RECEIVE ALL PAGES OF THIS FAX.  
510-614-8390

THANK YOU.

c) Tank and Piping Transporter

Name CROSEY & OVERTON EPA I.D. No. CAD982524480

Hauler License No. 2136 License Exp. Date 9-30-95

Address 8430 AMAELIA STREET

City OAKLAND State CA Zip 94621

d) Tank and Piping Disposal Site

Name ERICKSON EPA I.D. No. CAD009466392

Address 255 PARR BLVD.

City RICHMOND State CA Zip 94801

11. Experienced Sample Collector

Name TOM FOGET

Company WEISS AND ASSOCIATES

Address 5500 SHELLMOUND

City EMERYVILLE State CA Zip 94608 Phone 510 450-6120

12. Laboratory

Name SEQUOIA ANALYTICAL LABORATORY

Address 2549 MIDDLEFIELD RD.

City REDWOOD CITY State CA Zip 94063

State Certification No. 1271

13. Have tanks or pipes leaked in the past? Yes [ ] No [X]

If yes, describe. \_\_\_\_\_  
\_\_\_\_\_  
\_\_\_\_\_

# PARADISO MECHANICAL, INC.

## GENERAL & PETROLEUM CONTRACTORS and ENVIRONMENTAL SERVICES

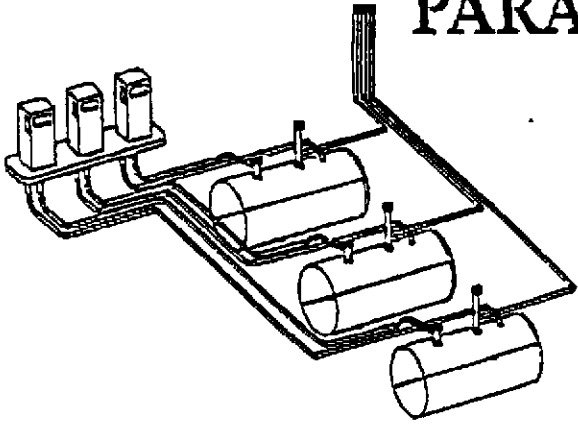

P.O. BOX 1838  
2600 WILLIAMS STREET  
SAN LEANDRO, CA 94577

LICENSE NO. 677909  
PHONE (510) 614-8390  
FAX (510) 614-8396

### FAX COVER SHEET

PARADISO FAX NUMBER 510-614-8396

DATE: 2/22/95

NUMBER OF PAGES INCLUDING COVER SHEET: 2

TO: Ala Co. Health ATTENTION: J. Shinn

FAX NUMBER: 510 337-9335

FROM: Linda Martin

SUBJECT: 9750 Golf Link Rd.

REMARK: Revised page 2 for permit application.

PLEASE CALL OUR OFFICE IF YOU DO NOT RECEIVE ALL PAGES OF THIS FAX.  
510-614-8390

THANK YOU.



6. Contractor PARADISCO MECHANICAL, INC.

Address 2600 WILLIAMS STREET

City SAN LEANDRO Phone 510/614-8390

License Type B,C8,C10,C61/D23 ID# 677909

\*Effective January 1, 1992, Business and Professional Code Section 7058.7 requires prime contractors to also hold Hazardous Waste Certification issued by the State Contractors License Board. Indicate that the certificate has been received, in addition, to holding the appropriate contractors license type.

7. Consultant WEISS AND ASSOCIATES

Address 5500 SHELLMOUND

City EMERYVILLE, CA. Phone 510 450-6120

8. Contact Person for Investigation

Name TOM FOGET Title \_\_\_\_\_

Phone 510 450-6120

9. Number of tanks being closed under this plan ONE

Length of piping being removed under this plan N/A

Total number of tanks at facility FIVE

10. State Registered Hazardous Waste Transporters/Facilities (see instructions).

\*\* Underground tanks are hazardous waste and must be handled \*\*  
as hazardous waste

a) Product/Residual Sludge/Rinsate Transporter

Name CROSBY & OVERTON EPA I.D. No. CAD982524480

Hauler License No. 2136 License Exp. Date 9-30-95

Address 8430 AMELIA STREET

City OAKLAND State CA Zip 94621

b) Product/Residual Sludge/Rinsate Disposal Site

Name ROMIC ENVIRONMENTAL EPA I.D. No. CAD009452657

Address 2081 BAY ROAD

City EAST PALO ALTO State CA Zip 94303

6. Contractor PARADISO MECHANICAL, INC.  
 Address 2600 WILLIAMS STREET  
 City SAN LEANDRO Phone 510/614-8390  
 License Type B,C8,C10,C61/D23 ID# 677909  
 \*Effective January 1, 1992, Business and Professional Code Section 7058.7 requires prime contractors to also hold Hazardous Waste Certification issued by the State Contractors License Board. Indicate that the certificate has been received, in addition, to holding the appropriate contractors license type.

7. Consultant WEISS AND ASSOCIATES  
 Address 5500 SHELLMOUND  
 City EMERYVILLE, CA. Phone 510 450-6120

8. Contact Person for Investigation  
 Name TOM FOGET Title \_\_\_\_\_  
 Phone 510 450-6120

9. Number of tanks being closed under this plan ONE  
 Length of piping being removed under this plan N/A  
 Total number of tanks at facility FIVE

10. State Registered Hazardous Waste Transporters/Facilities (see instructions).

\*\* Underground tanks are hazardous waste and must be handled \*\*  
 as hazardous waste

Used oil will a) Product/Residual Sludge/Rinsate Transporter  
 be pumped & hauled  
 to Evergreen Oil  
 6880 Smith Ave  
 Newark 94560  
 1-800-972-5284

Name CROSBY & OVERTON EPA I.D. No. CAD982524480  
 Hauler License No. 2135 License Exp. Date 9-30-95  
 Address 8430 AMELIA STREET  
 City OAKLAND State CA Zip 94621

b) Product/Residual Sludge/Rinsate Disposal Site  
 Name ROMIC ENVIRONMENTAL EPA I.D. No. CAD009452657  
 Address 2081 BAY ROAD  
 City EAST PALO ALTO State CA Zip 94303

c) Tank and Piping Transporter

Name CROSBY & OVERTON EPA I.D. No. CAD982524480  
Hauler License No. 2136 License Exp. Date 9-30-95  
Address 8430 AMAELIA STREET  
City OAKLAND State CA Zip 94621

\ d) Tank and Piping Disposal Site

Name ERICKSON EPA I.D. No. CAD009466392  
Address 255 PARR BLVD.  
City RICHMOND State CA Zip 94801

\ 11. Experienced Sample Collector

Name CRAIG ROBERTSON  
Company FUGRO WEST, INC.  
Address 1050 MELODY LANE #160  
City ROSEVILLE, State CA Zip \_\_\_\_\_ Phone 916 782-2110

\ 12. Laboratory

Name SEQUOIA ANALYTICAL LABORATORY  
Address 819 STRIKER AVENUE, SUITE #8  
City SACRAMENTO State CA Zip 95834  
State Certification No. 1271

13. Have tanks or pipes leaked in the past? Yes [ ] No [X]

If yes, describe. \_\_\_\_\_  
\_\_\_\_\_  
\_\_\_\_\_

14. Describe methods to be used for rendering tank inert

TRIPLE RINSE AND VACUUM OUT. Put dry ice into tank.

50lbs per 1,000-gallons

Before tanks are pumped out and inerted, all associated piping must be flushed out into the tanks. All accessible associated piping must then be removed. Inaccessible piping must be plugged.

The Bay Area Air Quality Management District (415-771-6000), along with local Fire and Building Departments, must also be contacted for tank removal permits. Fire departments typically require the use of explosion proof combustible gas meters to verify tank inertness. It is the contractor's responsibility to bring a working combustible gas meter on site to verify tank inertness.

15. Tank History and Sampling Information

Tank		Material to be sampled (tank contents, soil, ground water, etc.)	Location and Depth of Samples
Capacity	Use History (see instructions)		
500 GALLON	Waste Oil Tank	SOIL AROUND TANK; GROUND WATER IF ANY EXISTS.	<i>One A minimum of one soil sample from beneath tank. If groundwater present, one soil sample from each end of the tank at soil/water interface, + one groundwater sample required. The tank pit may be purged and allowed to refill before sampling.</i>

One soil sample must be collected for every 20 feet of piping that is removed. A ground water sample must be collected should any ground water be present in the excavation.

**Excavated/Stockpiled Soil**

<p align="center"><b>Stockpiled Soil Volume</b> (Estimated)</p>	<p align="center"><b>Sampling Plan</b></p> <p><i>One discreet soil sample per every 20 yd<sup>3</sup> of soil required if plans to reuse soil on site.</i></p> <p><i>One composite soil sample per every 50 yd<sup>3</sup> of soil required if plans to dispose of off site.</i></p>
---	--

Stockpiled soil must be placed on bermed plastic and must be completely covered by plastic sheeting.

16. Chemical methods and associated detection limits to be used for analyzing samples.

The Tri-Regional Board recommended minimum verification analyses and practical quantitation reporting limits should be followed. See attached Table 2.

Containment Sought	EPA, DHS, or Other Sample Preparation Method Number	EPA, DHS, or Other Analysis Method Number	Method Detection Limit
TPH G	5030		50 ppb (H <sub>2</sub> O); 1 ppm (soil)
TPH D	3550		" "
<del>TPH &amp; BTX&amp;E</del>	<del>8260</del> (redundant)		
O & G	5520 D & F		0.005 to 0.5 ppm soil
BTX&E	8240		6.5 ppb H <sub>2</sub> O
CL HC	8240		5,000 ppb (H <sub>2</sub> O)
METALS Cd, Cr, Pb, Zn, Ni	AA		50 ppm (soil)
Semi Volatiles	8270		

- 18. Submit Worker's Compensation Certificate copy  
Name of Insurer REPUBLIC INDEMNITY CO. OF AMERICA
- 19. Submit Plot Plan (See Instructions)
- 20. Enclose Deposit (See Instructions)
- 21. Report any leaks or contamination to this office within 5 days of discovery. The report shall be made on an Underground Storage Tank Unauthorized Leak/Contamination Site Report form. (See Instructions)
- 22. Submit a closure report to this office within 60 days of the tank removal. This report must contain all the information listed in item 22 of the instructions.

I declare that to the best of my knowledge and belief the statements and information provided above are correct and true.

I understand that information in addition to that provided above may be needed in order to obtain an approval from the Department of Environmental Health and that no work is to begin on this project until this plan is approved.

I understand that any changes in design, materials or equipment will void this plan if prior approval is not obtained.

I understand that all work performed during this project will be done in compliance with all applicable OSHA (Occupational Safety and Health Administration) requirements concerning personnel health and safety. I understand that site and worker safety are solely the responsibility of the property owner or his agent and that this responsibility is not shared nor assumed by the County of Alameda.

Once I have received my stamped, accepted closure plan, I will contact the project Hazardous Materials Specialist at least three working days in advance of site work to schedule the required inspections.

Signature of Contractor

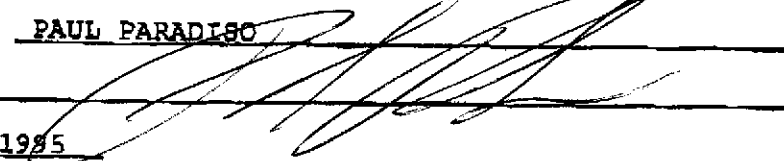
Name (please type) PAUL PARADISO  
 Signature   
 Date FEBRUARY 6, 1995

Signature of Site Owner or Operator

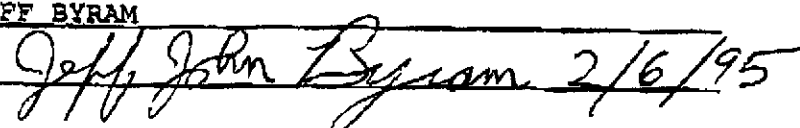
Name (please type) JEFF BYRAM  
 Signature  2/6/95  
 Date FEBRUARY 6, 1995

JAN 16 '95 20:07

P.1/1

→ Berkeley

I-580

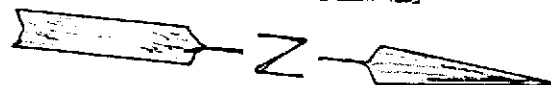

Golf links Rd

Canopy

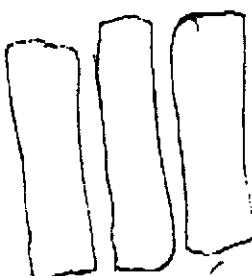
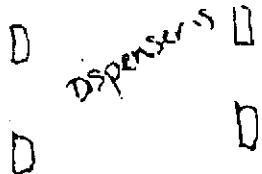

Fuel tanks

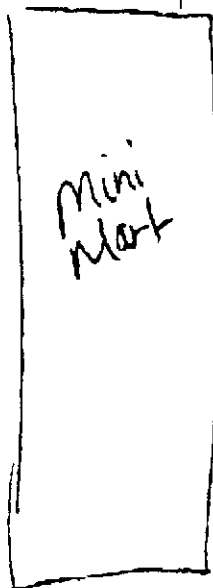

Gate



Waste oil tank

Gate

**ALAMEDA COUNTY HAZARDOUS MATERIALS DIVISION**  
**Declaration of Site Account Refund Recipient**  
 SITE OWNER FILLS OUT PER SITE  
 -- OPTIONAL --

The property owner will use this form to designate someone other than him- or her- self to receive any refund due at the completion of all deposit/refund projects at the site listed below. In the absence of this form, the property owner will receive any refund. Only one person at any one time may be designated to receive any refund.

SITE NUMBER/ADDRESS:

PROPERTY OWNER

\_\_\_\_\_  
 Site Number  
Shell Oil Company  
 Company Name

\_\_\_\_\_  
 Shell Oil Company  
 Owner's Name

9750 Golf Links Road  
 Street Address

1390 Willow Pass Road, Ste.900  
 Owner's Address

Oakland, Ca. 95605  
 City Zip Code

Concord, Ca. 94520  
 Owner's City State Zip

I designate the following person to receive any refund due at the completion of all deposit/refund projects:

Paul Paradiso  
 Name

2600 Williams St.,  
 Street Address

San Leandro, Ca. 94577  
 City / Zip

Jeff John Byram  
 Property Owner Signature

2-6-95  
 Date

JeffByram for Shell Oil Company  
 Property Owner Name

RETURN FORM TO: Alameda County, Hazardous Materials Div.  
 1131 Harbor Bay Parkway, Ste 250  
 Alameda, CA 94502-6577  
 Phone: (510) 567-6700



**PARADISO MECHANICAL, INC.**  
**GENERAL & PETROLEUM CONTRACTORS**

**LETTER OF TRANSMITTAL**

2600 WILLIAMS ST. P.O. BOX 1836  
 SAN LEANDRO, CA 94577  
 (510)614-8390 FAX (510)614-8396  
 CONTRACTORS LICENSE #677909

DATE <b>2/7/95</b>	JOB NO. <b>288</b>
ATTENTION <b>BARNEY CHAN</b>	
RE: <b>SHELL OIL CO.</b>	
<b>9750 GOLF LINKS ROAD</b>	
<b>OAKLAND</b>	

TO ALAMEDA COUNTY HEALTH CARE SERVICES  
DEPT. OF ENVIRONMENTAL HEALTH  
HAZARDOUS MATERIALS DIVISION  
1131 HARBOR BAY PARKWAY, STE 250  
ALAMEDA, CA. 94502-6700

WE ARE SENDING YOU  Attached  Under Separate Cover via U.S.MAIL the following items:

- Shop drawings       Prints       Plans       Samples       Specifications  
 Copy of Letter       Change Order  \_\_\_\_\_

COPIES	DATE	NO.	DESCRIPTION
3	2-6-95		UNDERGROUND TANK CLOSURE PLAN
3	2-1-95		STATE FORM A
3	2-1-95		STATE FORM B
3			CERTIFICATE OF INSURANCE
			CHECK FOR UNDERGROUND STORAGE FEE-\$603.
			COPIES OF CONTRACTOR LICENSES

THESE ARE TRANSMITTED as checked below:

- For approval       Approved as submitted       Resubmit \_\_\_\_\_ copies for approval  
 For your use       Approved as noted       Submit \_\_\_\_\_ copies for distribution  
 As requested       Returned for corrections       Return \_\_\_\_\_ corrected prints  
 For review and comment  \_\_\_\_\_  
 FOR BIDS DUE \_\_\_\_\_, 19\_\_\_\_       PRINTS RETURNED AFTER LOAN TO US

REMARKS ANY FURTHER INFORMATION NEEDED, PLEASE LET ME KNOW.  
 \_\_\_\_\_  
 \_\_\_\_\_  
 \_\_\_\_\_  
 \_\_\_\_\_  
 \_\_\_\_\_

COPY TO file \_\_\_\_\_  
 SIGNED: Linda Martin  
 LINDA MARTIN

# PARADISO MECHANICAL, INC.

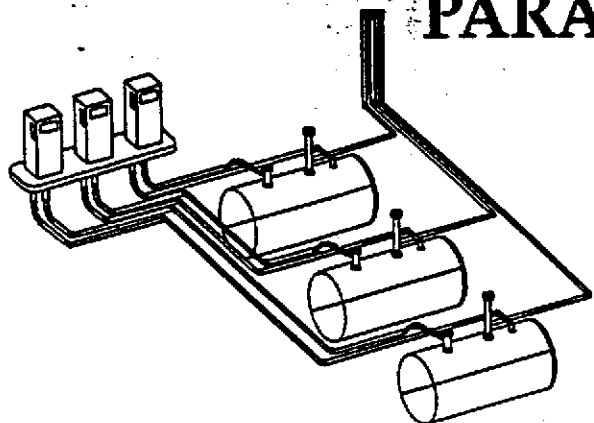

GENERAL & PETROLEUM CONTRACTORS  
and ENVIRONMENTAL SERVICES

P.O. BOX 1836  
2800 WILLIAMS STREET  
SAN LEANDRO, CA 94577

LICENSE NO. 677909  
PHONE (510) 614-8390  
FAX (510) 614-8396

S I T E   H E A L T H  
&  
S A F E T Y   P L A N

SHELL OIL  
9750 GOLF LINKS ROAD  
OAKLAND, CA

PARADISO PROJECT #95-288

JANUARY, 1995

EMERGENCY INFORMATION

IN CASE OF AN EMERGENCY, USE THIS SHEET

EMERGENCY PHONE NO:

911

SITE ADDRESS:

9750 GOLF LINKS ROAD  
OAKLAND, CA

NEAREST INTERSECTION:

KNOWLAND PARK

SITE LOCATION

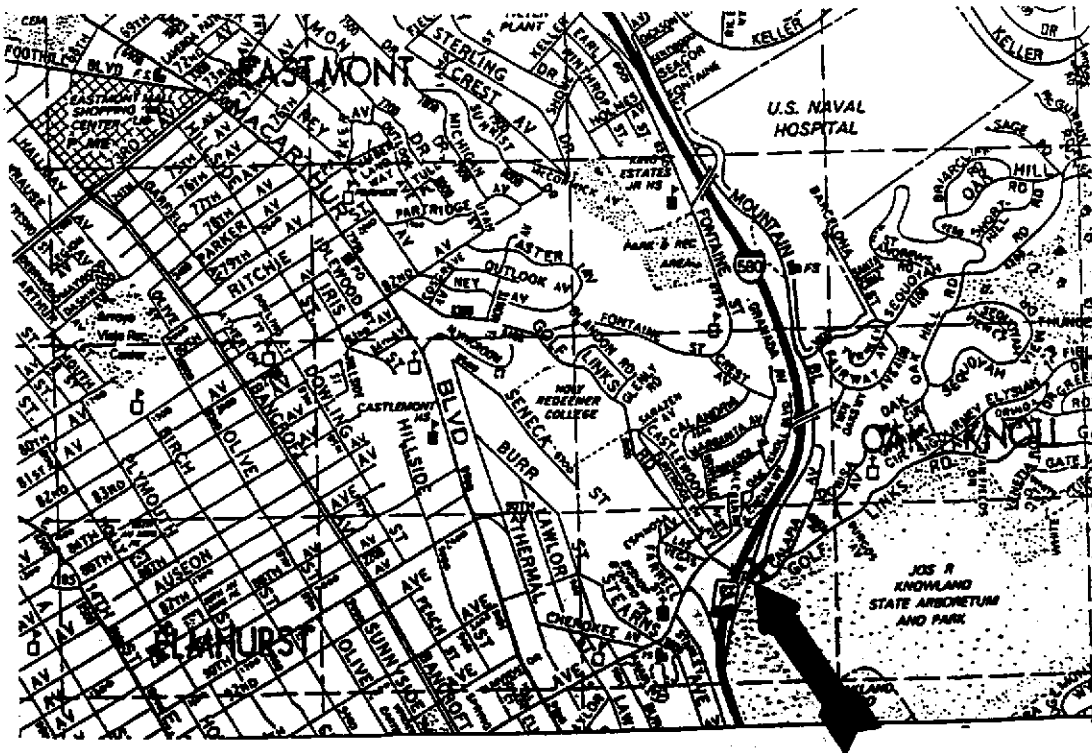

# C O N T E N T S

<u>SECTION</u>	<u>PAGE</u>
1.0 INTRODUCTION.....	4
2.0 WORK ACTIVITIES.....	4
2.1 SITE SECURITY.....	4
3.0 ONSITE ORGANIZATION.....	4
3.1 PROJECT CONTACTS.....	5
3.2 HEALTH AND SAFETY HAZARDS.....	6
3.3 HAZARD ANALYSIS.....	6
3.4 EXPOSURE PREVENTION & SAFETY REQUIREMENTS..	6
3.4.1 HAZARD EXPOSURE GUIDELINES.....	6
3.4.2 DIESEL & GASOLINE FUEL HAZARDS.....	7
3.4.3 TRAFFIC HAZARDS.....	8
3.4.4 OPEN EXCAVATION PIT HAZARDS.....	8
3.4.5 UNDERGROUND POWER LINE HAZARDS.....	8
3.4.6 PERSONAL SAFETY EQUIPMENT.....	9
3.4.7 GENERAL SAFETY EQUIPMENT.....	10
4.0 TRAINING.....	10
5.0 PROJECT-SPECIFIC TRAINING.....	10
6.0 LEVELS OF PROTECTION FOR EACH WORK ZONE.....	11
6.0.1 ASBESTOS.....	11
7.0 WASTE HANDLING AND DISPOSAL.....	12
8.0 PERSONAL INJURY.....	12
9.0 EMERGENCY PHONE NUMBERS.....	13
9.1 HOSPITAL/SITE MAP (FIGURE 1).....	14
10.0 OSHA STANDARD 29CFR1910.120 TRAINING INFO.....	15
11.0 SIGN IN SHEET.....	16
12.0 TRUCK ROUTE MAP.....	17

## 1.0 INTRODUCTION

Paradiso Mechanical will furnish labor and equipment to remove waste oil tank; backfill and compact; pave and off haul any excess asphalt or concrete.

This Health & Safety Plan is based on the work plan activities and the requirements of Title 29 of the Code of Federal Regulations, Section 1910.120 (29 CFR 1910.120).

## 2.0 WORK ACTIVITIES

The following subsections provide a description of the various work performed at the site, as well as health and safety hazards associated with each task.

### 2.1 SITE SECURITY

Access during all on-site activities will be restricted to authorized personnel. All personnel and authorized visitors must contact the Site Foreman/Safety Coordinator prior to entering and exiting the site.

## 3.0 ON-SITE ORGANIZATION

Each person shall be responsible for following the Health and Safety Plan's guidelines at the site. The Safety Officer is the appointed Foreman and his duties are as follows:

- Ensure that the Health and Safety Plan is implemented;
- Conduct "tailgate" meetings on a weekly basis and document items discussed;
- Conditions may change on site. Determine extent and conduct "tailgate" meetings on a basis that relates to conditions on site. Document items discussed.
- Stop work if the health and safety of workers is in question;
- Observe workers for signs and symptoms of exposure or heat stress;
- Evaluate the effectiveness of the personal protective equipment program on an ongoing basis and upgrade the program as needed;
- Inform the Field Supervisor of any deficiencies or

changes in health and safety practices;

- Perform daily review of the work practices and compliances with this Health and Safety Plan;
- Determine exclusion zones and assign personnel duties at each zone in case of an emergency;
- Prevent unauthorized personnel or equipment from entering the exclusion zones;

All essential and nonessential personnel entering or exiting any of the exclusion zones must comply with health and safety practices and procedures described in this Health and Safety Plan.

### 3.1 PROJECT CONTACTS

Unanticipated occurrences at the site must be reported to the following personnel as soon as possible:

- ERIC V. MONTESANO, Safety Coordinator 510-614-8390  
Paradiso Mechanical, Inc.  
San Leandro, CA 94577
- PAUL PARADISO, Project Manager 510-614-8390  
Paradiso Mechanical, Inc.  
San Leandro, CA 94577
- JEFF BYRAM, Engineer 510 675-6146  
Shell Oil Company  
Concord, Ca. 94520

3.2

HEALTH AND SAFETY HAZARDS

Health and safety concerns on site may consist of:

- Chemical hazards:
  - Diesel, Gasoline, Benzene, Toluene, Ethyl Benzene and Xylenes.
- Physical hazards:
  - Operation of heavy equipment;
  - Semi-Trucks/Automobiles and other vehicle traffic;
  - Excavation pits/trenches;
  - Underground electrical, water and sewer lines.

3.3

HAZARD ANALYSIS

To the best of our knowledge, the property previously operated gasoline, diesel, and waste oil tanks. Historic data and evaluation of subsurface data indicates the presence of elevated levels of petroleum hydrocarbons.

3.4

EXPOSURE PREVENTION AND SAFETY REQUIREMENTS

This section describes the hazard and danger of exposure to chemicals and physical hazards present at the site. Possible contingency plans and safety requirements are also presented on this section.

3.4.1

HAZARD EXPOSURE GUIDELINES

Substances	CAL OSHA PEL	1990-91 ZSVHOJ/ TLV
Benzene	1 ppm (TWA) 25 ppm (Ceiling)	1 ppm (TWA)
Toluene	100 ppm (TWA) 150 ppm (STEL)	100 ppm (TWA) 150 ppm (STEL)
Ethylbenzene	100 ppm (TWA) 125 ppm (STEL)	100 ppm (TWA) 125 ppm (STEL)
Xylene	100 ppm (TWA) 150 ppm (STEL)	100 ppm (TWA) 150 ppm (STEL)
Gasoline	300 ppm (TWA) 500 ppm (STEL)	300 ppm (TWA) 500 ppm (STEL)

Oil Mist	5 mg/m3 (TWA) 10 mg/m3 (STEL)	5 mg/m3 (TWA) 10 mg/m3 (STEL)
Petroleum Distillates	400 ppm (TWA)	400 ppm (TWA)

### 3.4.2 DIESEL & GASOLINE FUEL HAZARDS

A. Eye and skin exposure hazards: irritant

In case of exposure:

- Remove contaminated clothing and shoes;
- Flush affected areas with plenty of water for a minimum of 15 minutes;
- IF IN EYE, hold eyelids open and flush with plenty of water for a minimum of 15 minutes;
- If irritation or discomfort continues, seek medical aid immediately.

B. Internal exposure hazards: Harmful if swallowed.

In case of exposure:

- Seek medical attention;
- If victim is CONSCIOUS have victim drink water or milk;
- DO NOT INDUCE VOMITING.

C. Fire hazards: Combustible

Since flammable or combustible vapors are likely to be present, all potential sources of ignition must be eliminated. Caution must be taken to prevent the discharge of static electricity and to prevent accumulations of vapor at ground level. A combustible gas indicator should be used continuously to check hazardous vapor concentrations, lower explosive limit (LEL). Alarm of the combustible gas indicator should be set at 20% of LEL. Under alarm conditions, all work activities will cease and the area will be evacuated until the combustible vapor concentration can be controlled below 20% of the LEL. All open flame or spark-producing equipment in the area should be shut down and any electrical equipment used must be explosion proof.



In case of fire:

- Extinguish with dry chemical, foam or carbon dioxide.
- If fire cannot be extinguished within 30 seconds, call Fire Department immediately.
- Water may be ineffective on fire.

### 3.4.3 TRAFFIC HAZARDS

Stay at least 10 feet away from moving equipment. If closer than 10 feet:

- 1) Keep equipment in sight at all times;
- 2) Inform the operator of your location at all times.

The working area will be closed to traffic with barricades, caution tape, cones and other traffic control equipment. If the area cannot be barricaded, a flagperson will be assigned to direct traffic.

No unauthorized or unessential vehicles will be allowed to enter the barricaded area.

### 3.4.4 OPEN EXCAVATION PIT HAZARDS

Open excavation pits shall be clearly marked and barricaded. No confined space entry will be allowed. If a person falls into an open pit:

- DO NOT ENTER THE EXCAVATION PIT.
- If the person is conscious and can move, lower a ladder into the pit so that the person can climb out.
- If the person is unconscious, call the Fire Department.

### 3.4.5 UNDERGROUND POWER LINE HAZARDS

Call U.S. Alert at least 3 days before commencing excavation work. The owner will identify aboveground structures and utilities and will provide as-built blueprints for contractor use prior to start of project. If the location of underground utilities such as water, sewer or electrical lines is still unclear, the contractor will obtain the service of a utility location company before beginning any excavation. An area for excavated soil stockpile will be provided adjacent to the excavation.

If a power line is discovered or damaged during the work:

- Stop all activities.
- Stop all engines, mechanical and electrical equipment.
- Call Utility Company/U.S. Alert immediately.  
(U.S. Alert - 1-800-642-2444)

In case of electrical injury:

- Shut off the source of electrical power before attempting rescue or treatment.
- Seek professional electrical personnel (Fire Department) to assist in rescue.
- Beware of, and expect, live electrical currents.

#### 3.4.6 PERSONNEL SAFETY EQUIPMENT

The following personal protective equipment will be required AT ALL TIMES:

- Hard Hat
- Steel-toed shoes
- Safety glasses
- Nitrile gloves (required for personnel who will come in contact with soil or groundwater).

The following personal protective equipment will be optional or required as the need arises:

- Hearing protection equipment
- Coveralls - disposable (Tyvek), or fabric (any chemical protective needs).
- Gloves

Additional protection requirements are described in Section 6.0.

### 3.4.7 GENERAL SAFETY EQUIPMENT

The following equipment must be available and easily accessible for use:

- First Aid Kit
- Fire extinguishers (Foam, dry chemical or carbon dioxide)

Each company vehicle is equipped with the following items:

- First Aid Kit
- Fire Extinguisher
- "Stop/Slow" traffic signs
- Warning Triangle/Flair Kit

### 4.0 TRAINING

All personnel who may be exposed to onsite contaminants must provide documentation of the following:

- Current certification of 40 hours of (OSHA) classroom instruction/hands-on training to include:
  - Three days of field experience under the supervision of an experienced supervisor.
  - Eight hours of annual classroom refresher training.
- Eight hours of supervisory training if a team member is a designated supervisor.
- Hazard communications training.

### 5.0 PROJECT-SPECIFIC TRAINING

Project-specific training and information will be provided either before traveling to the site or at the site before entry into the exclusion zone. The information and training will be documented and will include the following:

- The contents of this Health and Safety Plan
- A discussion of the health and safety hazards; protective measures and work practices for handling contaminated soil, water or equipment.

## 6.0

### LEVELS OF PROTECTION FOR EACH WORK ZONE

Protective equipment has been selected for use in each work zone based on anticipated hazards. Specific protective equipment requirements are as follows:

- Exclusion zone - Level D protection will be required within the exclusion zone for any workers engaged in sample collection or other activities on site. Level D protection will include a hard hat, steel-toed boots, safety glasses, hearing protection, and Nitrile gloves. Coveralls are optional but recommended.
- Level C protection will be required if PID readings exceeding 100 ppm total volatile organics over background concentration are recorded in the workers breathing zone. Level C protection will consist of disposable Tyvek coveralls, steel-toed boots, chemical resistant boot covers, splash goggles, chemical resistant disposable gloves (inner) and chemical resistant outer gloves. MSHA/NIOSH approved half-face or full face air-purifying respirator with dual organic vapor cartridges.
- Support Zone - No specific requirements.

#### 6.0.1

##### ASBESTOS

Protective Clothing: Whenever there is a need for removing material containing asbestos, Contractor shall provide the following protective clothing or equipment and respirators.

- Full body disposable coveralls;
- Disposable shoe covers & hood;
- Impermeable gloves;
- Approved half mask or full face respirator with HEPA filter cartridge as a minimum;
- All protective clothing shall be handled and disposed in accordance with the applicable laws.

Asbestos Caution signs shall be displayed at all entrances to the work area in accordance with applicable laws.

**7.0****WASTE HANDLING AND DISPOSAL**

The waste handling procedures discussed in the work plan will be followed. Waste generated by implementation of this Health and Safety program may include spent protective clothing such as Tyvek suits, gloves and wash and rinse solutions. Protective clothing will be collected in a lined container. Liquid wastes will be collected and pumped or poured into holding tanks with equipment decontamination rinsate.

**8.0****PERSONAL INJURY**

In case of a minor personal injury, general first aid procedures should be implemented. A first aid kit will be available at the site at all times. More serious injuries may require assistance from paramedics. The Field Foreman or another designated person will contact the appropriate emergency personnel by dialing 911. Field Foreman or another designated person will contact the Safety Coordinator immediately following contact of medical personnel.

9.0

EMERGENCY PHONE NUMBERS

HOSPITAL LOCATIONS ON NEXT PAGE

Highland Hospital  
1411 E. 31st/14th Ave.  
Oakland, Ca. 94602  
510 534-8055

ReadiCare Medical Center  
7817 Oakport St./Roland Way  
Oakland, Calif. 94621  
510-638-0701

AMBULANCE

CALL 911

FIRE DEPARTMENT

CALL 911

POLICE DEPARTMENT

CALL 911

AGENCY TELEPHONE NUMBERS:

National Response Center  
800-424-8802

California Department of Health Services  
415-540-2043

Regional Water Quality Control Board  
415-464-1255

Bay Area Air Quality Management District  
415-771-6000

Environmental Protection Agency  
415-974-8076

Chemtrec  
800-424-9300

Department of Transportation  
415-876-9085

U.S. Alert Services  
800-642-2444

9750 Golf Links Rd./Knowland Park  
Oakland

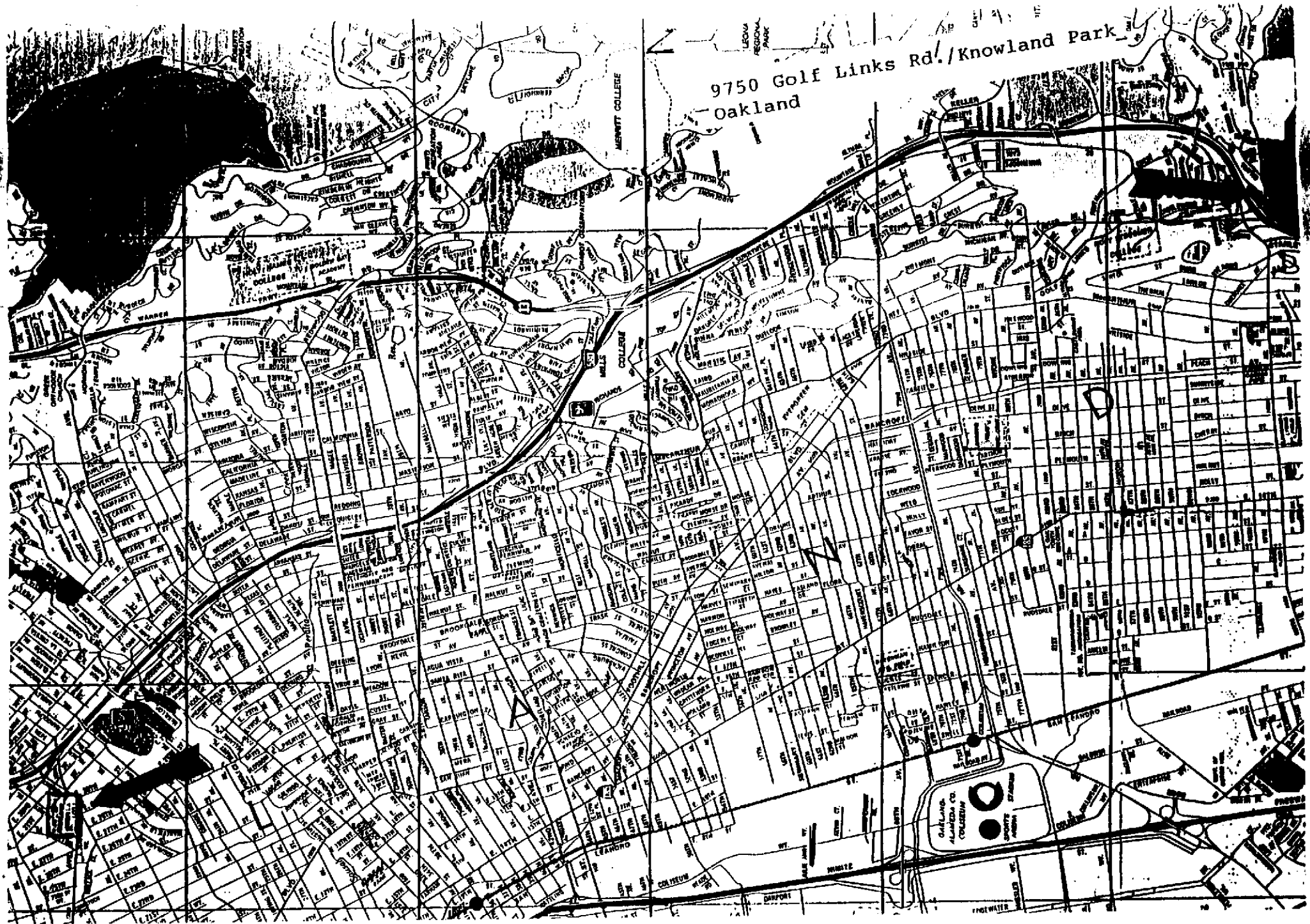

TO WHOM IT MAY CONCERN:

PARADISO MECHANICAL, INC. FIELD EMPLOYEES HAVE RECEIVED THE 40 HOUR TRAINING REQUIREMENT UNDER OSHA STANDARD 29CFR1910.120 HAZARDOUS WASTE OPERATIONS AND EMERGENCY RESPONSE TRAINING. ALL FIELD EMPLOYEES COMPLETED SUCH TRAINING FROM THE OCCUPATIONAL HEALTH AND SAFETY GROUP, INC., SANTA CLARA, CALIFORNIA, AND RECEIVED CERTIFICATES FOR COMPLETION OF SUCH TRAINING. CERTIFICATES ARE LOCATED AT THE HEAD OFFICE. FIELD EMPLOYEES HAVE IN THEIR POSSESSION AT ALL TIMES THE 40 HOUR OSHA TRAINING WALLET CARD.

MAY 1991





INSERT TRUCK ROUTE MAP



State of California  
**Contractors State License Board**

Pursuant to Chapter 9 of Division 3 of the Business and Professions Code  
and the Rules and Regulations of the Contractors State License Board,  
the Registrar of Contractors does hereby issue this license to:

**PARADISO MECHANICAL INC**



to engage in the business or act in the capacity of a contractor  
in the following classification(s):

- B - GENERAL BUILDING CONTRACTOR
- C-8 - CONCRETE
- C10 - ELECTRICAL (GENERAL)
- D23 - MEDICAL GAS SYSTEMS, PROCESS PIPING, BEVERAGE

Witness my hand and seal this day,  
November 5, 1993

Issued September 27, 1993

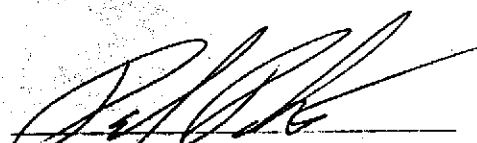
  
\_\_\_\_\_  
Signature of Licensee

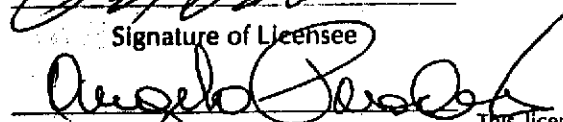
  
\_\_\_\_\_  
Signature of License Qualifier

This license is the property of the Registrar of Contractors, is not  
transferrable, and shall be returned to the Registrar upon demand  
when suspended, revoked, or invalidated for any reason. It becomes  
void if not renewed.



State of  
California  
Department of  
**Consumer  
Affairs**

  
\_\_\_\_\_  
Registrar of Contractors

677909

\_\_\_\_\_  
License Number

*Also licensed for A-General Engineering*

STATE OF CALIFORNIA

STATE AND CONSUMER SERVICES AGENCY CONTRACTORS STATE LICENSE BOARD



*Building Quality*



## HAZARDOUS SUBSTANCES REMOVAL AND REMEDIAL ACTIONS CERTIFICATION

Pursuant to the provisions of Section 7058.7 of the Business and Professions Code, the Registrar of Contractors does hereby certify that the following qualifying person has successfully completed the hazardous substances removal and remedial actions examination.

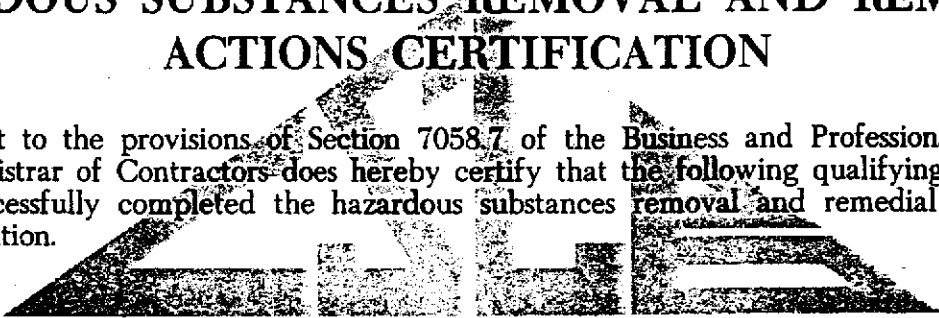

Qualifier: Paul Anthony Paradiso

License No.: 677909

Business Name: Paradiso Mechanical, Inc.



WITNESS my hand and official seal this  
4th day of November, 1993

*David R. Phillips*  
Registrar of Contractors

13L-36 (12/91)

This certification is the property of the Registrar of Contractors, is not transferable, and shall be returned to the Registrar upon demand when suspended, revoked, or invalidated for any reason.

A 5933

# AGORD. CERTIFICATE OF INSURANCE

DATE (MM/DD/YY)  
2/6/95

**PRODUCER**  
**MEIER COMMERCIAL INSURANCE**  
 11 EMBARCADERO WEST, STE. 133  
 OAKLAND, CALIFORNIA 94607  
 (510) 893-1222

THIS CERTIFICATE IS ISSUED AS A MATTER OF INFORMATION ONLY AND CONFERS NO RIGHTS UPON THE CERTIFICATE HOLDER. THIS CERTIFICATE DOES NOT AMEND, EXTEND OR ALTER THE COVERAGE AFFORDED BY THE POLICIES BELOW.

**COMPANIES AFFORDING COVERAGE**

**INSURED**  
 PARADISO MECHANICAL INC  
 PARADISO CONSTRUCTION CO  
 P.O. BOX 1836  
 SAN LEANDRO CA 94577

- COMPANY A
- COMPANY B
- COMPANY C
- COMPANY D REPUBLIC INDEMNITY CO OF AMERICA

THIS IS TO CERTIFY THAT THE POLICIES OF INSURANCE LISTED BELOW HAVE BEEN ISSUED TO THE INSURED NAMED ABOVE FOR THE POLICY PERIOD INDICATED, NOTWITHSTANDING ANY REQUIREMENT, TERM OR CONDITION OF ANY CONTRACT OR OTHER DOCUMENT WITH RESPECT TO WHICH THIS CERTIFICATE MAY BE ISSUED OR MAY PERTAIN, THE INSURANCE AFFORDED BY THE POLICIES DESCRIBED HEREIN IS SUBJECT TO ALL THE TERMS, EXCLUSIONS AND CONDITIONS OF SUCH POLICIES, LIMITS SHOWN MAY HAVE BEEN REDUCED BY PAID CLAIMS.

CO LTR	TYPE OF INSURANCE	POLICY NUMBER	POLICY EFFECTIVE DATE (MM/DD/YY)	POLICY EXPIRATION DATE (MM/DD/YY)	LIMITS
	<b>GENERAL LIABILITY</b> <input type="checkbox"/> COMMERCIAL GENERAL LIABILITY <input type="checkbox"/> CLAIMS MADE <input type="checkbox"/> OCCUR <input type="checkbox"/> OWNER'S & CONTRACTOR'S PROT				GENERAL AGGREGATE \$ PRODUCTS - COMPROP AGG \$ PERSONAL & ADV INJURY \$ EACH OCCURRENCE \$ FIRE DAMAGE (Any one fire) \$ MED EXP (Any one person) \$
	<b>AUTOMOBILE LIABILITY</b> <input type="checkbox"/> ANY AUTO <input type="checkbox"/> ALL OWNED AUTOS <input type="checkbox"/> SCHEDULED AUTOS <input type="checkbox"/> HIRED AUTOS <input type="checkbox"/> NON-OWNED AUTOS				COMBINED SINGLE LIMIT \$ BODILY INJURY (Per person) \$ BODILY INJURY (Per accident) \$ PROPERTY DAMAGE \$
	<b>GARAGE LIABILITY</b> <input type="checkbox"/> ANY AUTO				AUTO ONLY - EA ACCIDENT \$ OTHER THAN AUTO ONLY: EACH ACCIDENT \$ AGGREGATE \$
	<b>EXCESS LIABILITY</b> <input type="checkbox"/> UMBRELLA FORM <input type="checkbox"/> OTHER THAN UMBRELLA FORM				EACH OCCURRENCE \$ AGGREGATE \$
D	<b>WORKER'S COMPENSATION AND EMPLOYERS' LIABILITY</b> THE PROPRIETOR/PARTNERS/EXECUTIVE OFFICERS ARE: <input type="checkbox"/> INCL <input type="checkbox"/> EXCL	PC 945188	4/01/94	4/01/95	<input checked="" type="checkbox"/> STATUTORY LIMITS EACH ACCIDENT \$ 1,000,000 DISEASE - POLICY LIMIT \$ 1,000,000 DISEASE - EACH EMPLOYEE \$ 1,000,000
	OTHER				

**DESCRIPTION OF OPERATIONS/LOCATIONS/VEHICLES/SPECIAL ITEMS**

RE: SHELL OIL STATION  
 9750 GOLF LINK ROAD  
 OAKLAND, CA 94605

**CERTIFICATE HOLDER**  
 ALAMEDA ENVIRONMENTAL HEALTH DEPT  
 1311 HARBOR BAY PARKWAY, STE. 250  
 ALAMEDA, CA 94542-6577

SHOULD ANY OF THE ABOVE DESCRIBED POLICIES BE CANCELLED BEFORE THE EXPIRATION DATE THEREOF, THE ISSUING COMPANY WILL ENDEAVOR TO MAIL 10 DAYS WRITTEN NOTICE TO THE CERTIFICATE HOLDER NAMED TO THE LEFT. BUT FAILURE TO MAIL SUCH NOTICE SHALL IMPOSE NO OBLIGATION OR LIABILITY OF ANY KIND UPON THE COMPANY, ITS AGENTS OR REPRESENTATIVES.

AUTHORIZED REPRESENTATIVE  
 ANITA TONI MEIER *Anita Meier*

# AGORD. CERTIFICATE OF INSURANCE

DATE (MM/DD/YY)  
2/6/95

**PRODUCER**  
**MEIER COMMERCIAL INSURANCE**  
 11 EMBARCADERO WEST, STE. 133  
 OAKLAND, CALIFORNIA 94607  
 (510) 893-1222

THIS CERTIFICATE IS ISSUED AS A MATTER OF INFORMATION ONLY AND CONFERS NO RIGHTS UPON THE CERTIFICATE HOLDER. THIS CERTIFICATE DOES NOT AMEND, EXTEND OR ALTER THE COVERAGE AFFORDED BY THE POLICIES BELOW.

**COMPANIES AFFORDING COVERAGE**

**INSURED**  
**PARADISO MECHANICAL INC**  
**PARADISO CONSTRUCTION CO**  
 P.O. BOX 1836  
 SAN LEANDRO CA 94577

- COMPANY  
A
- COMPANY  
B
- COMPANY  
C
- COMPANY  
D     **REPUBLIC INDEMNITY CO OF AMERICA**

THIS IS TO CERTIFY THAT THE POLICIES OF INSURANCE LISTED BELOW HAVE BEEN ISSUED TO THE INSURED NAMED ABOVE FOR THE POLICY PERIOD INDICATED, NOTWITHSTANDING ANY REQUIREMENT, TERM OR CONDITION OF ANY CONTRACT OR OTHER DOCUMENT WITH RESPECT TO WHICH THIS CERTIFICATE MAY BE ISSUED OR MAY PERTAIN, THE INSURANCE AFFORDED BY THE POLICIES DESCRIBED HEREIN IS SUBJECT TO ALL THE TERMS, EXCLUSIONS AND CONDITIONS OF SUCH POLICIES. LIMITS SHOWN MAY HAVE BEEN REDUCED BY PAID CLAIMS.

CO LTR	TYPE OF INSURANCE	POLICY NUMBER	POLICY EFFECTIVE DATE (MM/DD/YY)	POLICY EXPIRATION DATE (MM/DD/YY)	LIMITS
	<b>GENERAL LIABILITY</b> <input type="checkbox"/> COMMERCIAL GENERAL LIABILITY <input type="checkbox"/> CLAIMS MADE <input type="checkbox"/> OCCUR <input type="checkbox"/> OWNER'S & CONTRACTOR'S PROT				GENERAL AGGREGATE \$ PRODUCTS - COMPROP AGG \$ PERSONAL & ADV INJURY \$ EACH OCCURRENCE \$ FIRE DAMAGE (Any one fire) \$ MED EXP (Any one person) \$
	<b>AUTOMOBILE LIABILITY</b> <input type="checkbox"/> ANY AUTO <input type="checkbox"/> ALL OWNED AUTOS <input type="checkbox"/> SCHEDULED AUTOS <input type="checkbox"/> HIRED AUTOS <input type="checkbox"/> NON-OWNED AUTOS				COMBINED SINGLE LIMIT \$ BODILY INJURY (Per person) \$ BODILY INJURY (Per accident) \$ PROPERTY DAMAGE \$
	<b>GARAGE LIABILITY</b> <input type="checkbox"/> ANY AUTO				AUTO ONLY - EA ACCIDENT \$ OTHER THAN AUTO ONLY: EACH ACCIDENT \$ AGGREGATE \$
	<b>EXCESS LIABILITY</b> <input type="checkbox"/> UMBRELLA FORM <input type="checkbox"/> OTHER THAN UMBRELLA FORM				EACH OCCURRENCE \$ AGGREGATE \$
D	<b>WORKER'S COMPENSATION AND EMPLOYERS' LIABILITY</b> THE PROPRIETOR/PARTNERS/EXECUTIVE OFFICERS ARE: <input type="checkbox"/> INCL <input type="checkbox"/> EXCL	PC 945188	4/01/94	4/01/95	<input checked="" type="checkbox"/> STATUTORY LIMITS EACH ACCIDENT \$ 1,000,000 DISEASE - POLICY LIMIT \$ 1,000,000 DISEASE - EACH EMPLOYEE \$ 1,000,000
	OTHER				

**DESCRIPTION OF OPERATIONS/LOCATIONS/VEHICLES/SPECIAL ITEMS**  
 RE: SHELL OIL STATION  
 9750 GOLF LINK ROAD  
 OAKLAND, CA 94605

**CERTIFICATE HOLDER**  
 ALAMEDA ENVIRONMENTAL HEALTH DEPT  
 1311 HARBOR BAY PARKWAY, STE. 250  
 ALAMEDA, CA 94542-6577

SHOULD ANY OF THE ABOVE DESCRIBED POLICIES BE CANCELLED BEFORE THE EXPIRATION DATE THEREOF, THE ISSUING COMPANY WILL ENDEAVOR TO MAIL 10 DAYS WRITTEN NOTICE TO THE CERTIFICATE HOLDER NAMED TO THE LEFT, BUT FAILURE TO MAIL SUCH NOTICE SHALL IMPOSE NO OBLIGATION OR LIABILITY OF ANY KIND UPON THE COMPANY, ITS AGENTS OR REPRESENTATIVES.

AUTHORIZED REPRESENTATIVE  
**ANITA TONI MEIER** *Anita Meier*

**AGORD. CERTIFICATE OF INSURANCE**

DATE (MM/DD/YY)  
2/6/95

**PRODUCER**  
MEIER COMMERCIAL INSURANCE  
11 EMBARCADERO WEST, STE. 133  
OAKLAND, CALIFORNIA 94607  
(510) 893-1222

THIS CERTIFICATE IS ISSUED AS A MATTER OF INFORMATION ONLY AND CONFERS NO RIGHTS UPON THE CERTIFICATE HOLDER. THIS CERTIFICATE DOES NOT AMEND, EXTEND OR ALTER THE COVERAGE AFFORDED BY THE POLICIES BELOW.  
COMPANIES AFFORDING COVERAGE

**INSURED**  
PARADISO MECHANICAL INC  
PARADISO CONSTRUCTION CO  
P.O. BOX 1836  
SAN LEANDRO CA 94577

- COMPANY A
- COMPANY B
- COMPANY C
- COMPANY D REPUBLIC INDEMNITY CO OF AMERICA

THIS IS TO CERTIFY THAT THE POLICIES OF INSURANCE LISTED BELOW HAVE BEEN ISSUED TO THE INSURED NAMED ABOVE FOR THE POLICY PERIOD INDICATED, NOTWITHSTANDING ANY REQUIREMENT, TERM OR CONDITION OF ANY CONTRACT OR OTHER DOCUMENT WITH RESPECT TO WHICH THIS CERTIFICATE MAY BE ISSUED OR MAY PERTAIN, THE INSURANCE AFFORDED BY THE POLICIES DESCRIBED HEREIN IS SUBJECT TO ALL THE TERMS, EXCLUSIONS AND CONDITIONS OF SUCH POLICIES, LIMITS SHOWN MAY HAVE BEEN REDUCED BY PAID CLAIMS.

CO LTR	TYPE OF INSURANCE	POLICY NUMBER	POLICY EFFECTIVE DATE (MM/DD/YY)	POLICY EXPIRATION DATE (MM/DD/YY)	LIMITS
	<b>GENERAL LIABILITY</b> <input type="checkbox"/> COMMERCIAL GENERAL LIABILITY <input type="checkbox"/> CLAIMS MADE <input type="checkbox"/> OCCUR <input type="checkbox"/> OWNER'S & CONTRACTOR'S PROT				GENERAL AGGREGATE \$ PRODUCTS - COMPROP AGG \$ PERSONAL & ADV INJURY \$ EACH OCCURRENCE \$ FIRE DAMAGE (Any one fire) \$ MED EXP (Any one person) \$
	<b>AUTOMOBILE LIABILITY</b> <input type="checkbox"/> ANY AUTO <input type="checkbox"/> ALL OWNED AUTOS <input type="checkbox"/> SCHEDULED AUTOS <input type="checkbox"/> HIRED AUTOS <input type="checkbox"/> NON-OWNED AUTOS				COMBINED SINGLE LIMIT \$ BODILY INJURY (Per person) \$ BODILY INJURY (Per accident) \$ PROPERTY DAMAGE \$
	<b>GARAGE LIABILITY</b> <input type="checkbox"/> ANY AUTO				AUTO ONLY - EA ACCIDENT \$ OTHER THAN AUTO ONLY: EACH ACCIDENT \$ AGGREGATE \$
	<b>EXCESS LIABILITY</b> <input type="checkbox"/> UMBRELLA FORM <input type="checkbox"/> OTHER THAN UMBRELLA FORM				EACH OCCURRENCE \$ AGGREGATE \$
D	<b>WORKER'S COMPENSATION AND EMPLOYERS' LIABILITY</b> THE PROPRIETOR/PARTNERS/EXECUTIVE OFFICERS ARE: <input type="checkbox"/> INCL <input type="checkbox"/> EXCL	PC 945188	4/01/94	4/01/95	<input checked="" type="checkbox"/> STATUTORY LIMITS EACH ACCIDENT \$ 1,000,000 DISEASE - POLICY LIMIT \$ 1,000,000 DISEASE - EACH EMPLOYEE \$ 1,000,000
	OTHER				

**DESCRIPTION OF OPERATIONS/LOCATIONS/VEHICLES/SPECIAL ITEMS**

RE: SHELL OIL STATION  
9750 GOLF LINK ROAD  
OAKLAND, CA 94605

**CERTIFICATE HOLDER**  
ALAMEDA ENVIRONMENTAL HEALTH DEPT  
1311 HARBOR BAY PARKWAY, STE. 250  
ALAMEDA, CA 94542-6577

SHOULD ANY OF THE ABOVE DESCRIBED POLICIES BE CANCELLED BEFORE THE EXPIRATION DATE THEREOF, THE ISSUING COMPANY WILL ENDEAVOR TO MAIL 10 DAYS WRITTEN NOTICE TO THE CERTIFICATE HOLDER NAMED TO THE LEFT, BUT FAILURE TO MAIL SUCH NOTICE SHALL IMPOSE NO OBLIGATION OR LIABILITY OF ANY KIND UPON THE COMPANY, ITS AGENTS OR REPRESENTATIVES.

AUTHORIZED REPRESENTATIVE  
ANITA TONI MEIER *Anita Meier*

REMOVALS

FILE OR PER NO.	ENVELOPE No. _____ of _____	PLAN REVIEW \$ 333. Rec'd. <i>Jan 3/17/89</i>	By	Date		By	Date		By	Date
<input type="checkbox"/> OWNER <i>M &amp; S STEEL</i>	Address <i>9750 Golf Links Rd. Oakland 94605</i>	No. <i>1</i> Plans Rec'd.			POOL Pre-Concrete/Gunite				U.G. TANKS Pre-Covering	
<input type="checkbox"/> Contractor <i>R H Lee &amp; Assoc</i>	Address <i>900 Linksport Lane Larkspur</i>	Plans Approved			Pre-Plaster					
<input type="checkbox"/> OTHER (Specify)	Address	Layout Made			Final					
<input checked="" type="checkbox"/> CONTACT FOR INVESTIGATION <i>RAY NEWSOME</i>	Phone	Rejected			EXCAVATION Septic Tank				Final	
		Applicant Notified			Absorption Field					
		Plans Returned			Absorption Bed					
		Permit Issued			House Sewer					
		CONSTRUCTION PROGRESS ACCEPTANCE			FINAL Septic Tank					
		Pre-Plaster/drywall			Absorption Field					
		Pre-Final			Absorption Bed					
		Final			OTHER					

*LOD*  
*STND 3672*

XR		REMARKS	
Date	By	Date	By
4/4/89	C.S.		
4/5/89	C.S.		
5/1/89	C.S.		
3/1/90	C.S.		

4/4/89 C.S. Plan review

4/5/89 C.S. All necessary work on records of Ray Newsome that a site safety plan is needed before I can approve the removal.

5/1/89 C.S. Tell Lee that I need site safety plan.

3/1/90 C.S. Ray Militar of Robert Lee said he will submit to me the final lab results and date the tank was removed.

Vicinity Map

Project # *U528868*

Fee Paid *\$ 333*

Date *3/17/89*

projects 468 A+B closed out 3/31/97  
P. Smith



**ROBERT H. LEE & ASSOCIATES, INC.**

900 Larkspur Landing Circle  
Suite 125

LARKSPUR, CALIFORNIA 94939

(415) 461-8890

TO ALAMEDA CO. HEALTH DEPT.  
HAZARDOUS MATERIALS DIVISION

**LETTER OF TRANSMITTAL**

DATE	5-1-89	JOB NO.	6839
ATTENTION	LARRY SEGO		
RE:	WASTE OIL TANK REMOVAL AT SHELL SERVICE STATION 9750 GOLF LINKS RD. OAKLAND, CA 94605		

WE ARE SENDING YOU  Attached  Under separate cover via \_\_\_\_\_ the following items:

- Shop drawings     Prints     Plans     Samples     Specifications  
 Copy of letter     Change order     \_\_\_\_\_

COPIES	DATE	NO.	DESCRIPTION
2		A-1	PLUG PLAN <span style="float: right;">5/5/89</span>
2			TANK REMOVAL APPLICATION <span style="float: right;">ALAMEDA COUNTY</span>
2			CLOSURE PLAN <span style="float: right;">DEPT. OF ENVIRONMENTAL HEALTH</span>
3			SITE SAFETY PLAN <span style="float: right;">HAZARDOUS MATERIALS</span>

THESE ARE TRANSMITTED as checked below:

- For approval     Approved as submitted     Resubmit \_\_\_\_\_ copies for approval  
 For your use     Approved as noted     Submit \_\_\_\_\_ copies for distribution  
 As requested     Returned for corrections     Return \_\_\_\_\_ corrected prints  
 For review and comment     \_\_\_\_\_  
 FOR BIDS DUE \_\_\_\_\_ 19 \_\_\_\_\_     PRINTS RETURNED AFTER LOAN TO US

REMARKS \_\_\_\_\_  
 \_\_\_\_\_  
 \_\_\_\_\_  
 \_\_\_\_\_  
 \_\_\_\_\_  
 \_\_\_\_\_  
 \_\_\_\_\_  
 \_\_\_\_\_  
 \_\_\_\_\_  
 \_\_\_\_\_

COPY TO \_\_\_\_\_ SIGNED: Lee E. Auerbach



SITE INFORMATION

Shell Oil Co  
 9750 Golf Links Rd  
 Oakland 94605  
 Site Contact:  
 Site Phone : 562-5616

StID: 3672 Site#: 468  
 PROJECT#: 468A  
 PROJECT TYPE:\*\*\* R \*\*\*  
 INSP: Larry Seto  
 ACCT. SHEET PG #: 1

PROPERTY OWNER INFORMATION

Owner Contact:  
 Owner Phone :

PAYOR INFORMATION

Robert H. Lee & Assoc.  
 900 Larkspur Landing Cir#125  
 Larkspur CA 94939 # 76  
 Payor Contact:  
 Payor Phone :

Date	Action Taken	Insp Init	Hours Spent/ Depstd	Hour Balnce	Money Spent/ Depositd	Money Balance
3/17/89	Rcpt# 528868 Balance from Prev. Page	.....	.....	.....	.....	333.00
5/4/89	plan review		1.0	56./hr	56.-	277.-
5/4/89	plan review		0.25		14.-	243.-
	previously debited - Candace					
June 89	ton removal		2.0	56	112	151.-
July	Sampling Report review/VLR		1.5	56	84	67.-
89-91	Review Technical Report - letters		2.0	60	120	-53.-
2/21/92	Transfer to Log		0.5	71.00 42.60	42.60	-95.60

UPON COMPLETION OF PROJECT

PROJ COMPLETED BY : Paul on. Price ATTACH:  State Forms A, B & C  
 Billing Adjustment\*  
 DATE OF COMPLETION : 3/31/97 DATE SENT TO BILLING: 3/31/97  
 TOTAL COST OF PROJECT: 333.00 REFUND AMOUNT: 0 Rev. 7/96

\* Billing adjustment forms needed when site is in our UST program.

ALAMEDA COUNTY HAZARDOUS MATERIALS DIVISION  
DEPOSIT / REFUND ACCOUNT SHEET

printed 03/31/97

SITE INFORMATION

Shell Oil Co  
9750 Golf Links Rd  
Oakland 94605  
Site Contact:  
Site Phone : 562-5616

StID: 3672 Site#: 468  
PROJECT#: 468B  
PROJECT TYPE:\*\*\* R \*\*\*  
INSP: clerical  
ACCT. SHEET PG #: 1

PROPERTY OWNER INFORMATION

Owner Contact:  
Owner Phone :

PAYOR INFORMATION

Paradiso Construction Co  
P O Box 1836  
San Leandro CA 94577 # 64  
Payor Contact: Ms Linda Martin  
Payor Phone : 510/614-8390

Date	Action Taken	Insp Init	Hours Spent/ Depstd	Hour Balnce	Money Spent/ Depositd	Money Balance
2/10/95	Rcpt# 752115 333.- Balance from Prev. Page					333.-
2/16/95	Admin charge		1	90.		243
2/16/95	Review closure plans		1.5	135.		108.
2/22/95	Rev./Fax/mail papers previously debited		0.2	18.-		90
3/31/97	carry over reg balance -95.60 from proj 468A				-95.60	-5.60

UPON COMPLETION OF PROJECT

PROJ COMPLETED BY : Paul M. Aron ATTACH:  State Forms A, B & C  
 Billing Adjustment\*  
DATE OF COMPLETION : 3/31/97 DATE SENT TO BILLING: 3/31/97  
TOTAL COST OF PROJECT: 333. REFUND AMOUNT: 0 Rev. 7/96

\* Billing adjustment forms needed when site is in our UST program.

**\*\* PAYOR INFORMATION \*\***

> Project # ---468B for Payor # 64 Paradiso Construction Co.  
 2600 WILLIAMS STREET  
 SAN LEANDRO CA 94577

> Project # ---468A for Payor # 76 Robert H Lee & Assoc.  
 900 Larkspur Landing #125  
 Larkspur CA 94939

**\*\* DEPOSIT HISTORY \*\***

Proj#	Deposit Date	Receipt#	Amount Received
---	---	---	---
---468A	03/17/89	528868	\$ 333.00
---	---	---	---
---	---	---	\$ 333.00
---468B	02/16/95	752115	\$ 603.00
---	---	---	---
---	---	---	\$ 603.00

**\*\* WORKLOG HISTORY \*\***

Proj#	Work Date	Activity Description	Insp	Time (hrs)	Amt Charged
---	---	---	---	---	---
---468A	05/04/89	plan review 1 hr @\$56/hr			\$56.00
---468a	05/04/89	plan review @\$56/hr		0.25	\$14.00
---	---	---	---	---	---
---	---	---	---	---	\$70.00

Balance: \$263.00 Amount Refunded:

Proj#	Work Date	Activity Description	Insp	Time (hrs)	Amt Charged
---	---	---	---	---	---
---468B	02/16/95	ADMINISTRATIVE CHARGE		1.	\$90.00
---468B	02/16/95	REVIEW CLOSURE PLANS		1.5	\$135.00
---468B	02/22/95	REV./FAX/MAIL PAPERS		0.2	\$18.00
---	---	---	---	---	---
---	---	---	---	---	\$243.00

Balance: \$263.00 Amount Refunded:

Listing HAZMAT DAILY activities since 1987 for StID # 3672  
as of 03/31/97

at 9750 Golf Links Rd , Oakland CA 94605

InspDat	Insp	DailBDat	Act	InspT	StID	COMMENTS
-----	-----	-----	-----	-----	-----	-----
InspDat	Insp	DailBDat	Act	InspT	StID	Comment
-----	-----	-----	-----	-----	-----	-----
02/21/92	EC		75	0.5	3672	<del>transfer to LOP</del>
03/16/93	RO		35	0.5	3672	UGT file review
11/29/93	KT		35	0.5	3672	
02/01/94	KT		33	1.5	3672	
02/02/94	RO		50	0.5	3672	New HMBP inspection
02/02/94	RO		120	2.	3672	Keep garbage dumpster covered at all times. Remove unnecessary articles and debris off ground behind building. Clean up oil and other stains in fueling and parking areas. Comments: There is ongoing cement repair work in the fueling and parking areas. This resulted in cement stains and dirty standing water in a low are that needs to be cleaned up when job is finished. An ice maker drains water to the rear of the building ground surface. There are no storm drains on the premises.
08/30/94	RO		55	1.	3672	HMBP review
01/10/95	DH		39	0.1	3672	<del>distrib NDE line test notif</del>
02/16/95	JMS	Project 468 B	45	1.5	3672	Reviewed closure plans, spoke to State DHS, Craig Robertson twice, Paul Paradiso, called Certif. Lab, and checked contractor's board license classes
02/17/95	DH		35	0.1	3672	1/10/95 line, 1/17/95 an IR '94
02/22/95	JMS		45	0.2	3672	Replaced revised pages of closure plan and mailed
09/22/95	KT		138	0.2	3672	rec'd HMMP insert to be used as a spill and monitoring plan update and recert..
02/13/96	DH		35	0.2	3672	'95 IR
02/29/96	DH		137	0.2	3672	2/22/96
04/15/96	DH		35	0.5	3672	mon cert 2/22/96
10/08/96	KT		138	0.2	3672	rec'd new HMMP and mon. and spill plan.

↑  
Project 468 A

↓

Complete

Printed: 03/31/97

\*\*\*\*\* Alameda County Department of Environmental Health \*\*\*\*\*  
Billing's Total Deposit/Refund History for All Accounts at Site

\*\* SITE INFORMATION \*\*

Site#: 468 -- StID: 3672 M & S Shell  
Date Open: 02/16/95 9750 Golf Links Rd.  
Date Closed: Oakland CA 94605

Listing HAZMAT DAILY activities since 1987 for StID # 3672  
as of 04/02/97

at 9750 Golf Links Rd , Oakland CA 94605

InspDat	Insp	DailBDat	Act	InspT	StID	COMMENTS
-----	----	-----	---	-----	-----	-----
InspDat	Insp	DailBDat	Act	InspT	StID	Comment
-----	----	-----	---	-----	-----	-----
02/21/92	EC		75	0.5	3672	transfer to LOP
03/16/93	RO		35	0.5	3672	UGT file review
11/29/93	KT		35	0.5	3672	
02/01/94	KT		33	1.5	3672	
02/02/94	RO		50	0.5	3672	New HMBP inspection
02/02/94	RO		120	2.	3672	Keep garbage dumpster covered at all times. Remove unnecessary articles and debris off ground behind building. Clean up oil and other stains in fueling and parking areas. Comments: There is ongoing cement repair work in the fueling and parking areas. This resulted in cement stains and dirty standing water in a low are that needs to be cleaned up when job is finished. An ice maker drains water to the rear of the building ground surface. There are no storm drains on the premises.
08/30/94	RO		55	1.	3672	HMBP review
01/10/95	DH		39	0.1	3672	distrib NDE line test notif
02/16/95	JMS		45	1.5	3672	Reviewed closure plans, spoke to State DHS, Craig Robertson twice, Paul Paradiso, called Certif. Lab, and checked contractor's board license classes
02/17/95	DH		35	0.1	3672	1/10/95 line, 1/17/95 an IR '94
02/22/95	JMS		45	0.2	3672	Replaced revised pages of closure plan and mailed
09/22/95	KT		138	0.2	3672	rec'd HMMP insert to be used as a spill and monitoring plan update and recert..
02/13/96	DH		35	0.2	3672	'95 IR
02/29/96	DH		137	0.2	3672	2/22/96
04/15/96	DH		35	0.5	3672	mon cert 2/22/96
10/08/96	KT		138	0.2	3672	rec'd new HMMP and mon. and spill plan.

Complete

ACCEPTED

DEPARTMENT OF ENVIRONMENTAL HEALTH

470 - 27th Street, Third Floor

Oakland, CA 94612

Telephone: (415) 874-7237

5/14/89

See modification

for item #13.

C.S.

These plans have been reviewed and found to be acceptable and essentially meet the requirements of State and local health laws. Changes to your plans indicated by this Department are to assure compliance with State and local laws. The project proposed herein is now retained for issuance of any required building permits for construction.

One copy of these accepted plans must be on the job and available to all contractors and craftsmen involved with the removal.

Any change or alterations of these plans and specifications must be submitted to this Department and to the Fire and Building Inspection Department to determine if such changes meet the requirements of State and local laws.

Notify this Department at least 48 hours prior to the following required inspections:

- Removal of Tank and Piping
- Sampling
- Final Inspection

Issuance of a permit to operate is dependent upon compliance with accepted plans and all applicable State and local regulations.

THERE IS A FINANCIAL PENALTY FOR NOT OBTAINING THESE INSPECTIONS.

ALAMEDA COUNTY HEALTH CARE SERVICES AGENCY  
DEPARTMENT OF ENVIRONMENTAL HEALTH  
HAZARDOUS MATERIALS DIVISION

80 SWAN WAY, ROOM 200  
OAKLAND, CA 94621  
PHONE NO. 415/271-4320

Project # 1528868  
Fee \$ 333.  
3/17/89

UNDERGROUND TANK CLOSURE/MODIFICATION PLANS

- Business Name M AND S SHELL  
Business Owner MR. MASHOON
- Site Address 9750 GOLF LINKS ROAD  
City OAKLAND Zip 94605 Phone 562-5616
- Mailing Address P.O. Box 4023  
City CONCORD Zip 94520 Phone 676-1414
- Land Owner SHELL OIL COMPANY  
Address P.O. Box 4023 city, state CONCORD, CA zip 94520
- EPA I.D. No. CAD 981402928
- Contractor PETROLEUM ENGINEERING, INC.  
Address 11 W. NINTH ST.  
City SANTA ROSA, CA 95401 Phone (707) 545-0360  
License Type A, B, C-10, C-61 ID# 224358
- Consultant \_\_\_\_\_  
Address \_\_\_\_\_  
City \_\_\_\_\_ Phone \_\_\_\_\_



8. Contact Person for Investigation

Name RAY NEWSOME Title SHELL ENGINEER

Phone (415) 676-1414 EXT. 128

9. Total No. of Tanks at facility 1 WASTE OIL TANK TO BE REMOVED

10. Have permit applications for all tanks been submitted to this office? Yes [] No []

11. State Registered Hazardous Waste Transporters/Facilities

a) Product/Waste Tranporter

Name CROSBY OVERTON EPA I.D. No. CAD 981461064

Address 8430 AMELIA ST.

City OAKLAND State CA Zip 94107

b) Rinsate Transporter

Name CROSBY OVERTON EPA I.D. No. CAD 981461064

Address 8430 AMELIA ST.

City OAKLAND State CA Zip 94107

c) Tank Transporter

Name CROSBY OVERTON EPA I.D. No. CAD 981461064

Address 8430 AMELIA ST.

City OAKLAND State CA Zip 94107

d) Tank Disposal Site

Name CROSBY OVERTON EPA I.D. No. CAD 981461064

Address 8430 AMELIA ST.

City OAKLAND State CA Zip 94107

e) Contaminated Soil Transporter

Name CROSBY OVERTON EPA I.D. No. CAD 981461064

Address 8430 AMELIA ST.

City OAKLAND State CA Zip 94107

12. Sample Collector

Name MR. MARDO KAPREALIAN  
 Company KAPREALIAN ENGINEERING  
 Address P.O. Box 913  
 City BENECIA State CA Zip 94510 Phone (707) 746-6915

13. Sampling Information for each tank or area

Tank or Area		Material sampled	Location & Depth
Capacity	Historic Contents (past 5 years)		
550 GAL.	WASTE OIL	NATIVE SOIL and ground water is present	2'-0" BENEATH REMOVED TANK Under both ends of tank at the soil/backfill interface into 2' of the native soil.

14. Have tanks or pipes leaked in the past? Yes [ ] No [ ]

If yes, describe. UNKNOWN

15. NFPA methods used for rendering tank inert? Yes [X] No [ ]

If yes, describe. ADDING 1.5 lbs. OF DRY ICE PER 100 GALLONS OF TANK CAPACITY.

An explosion proof combustible gas meter shall be used to verify tank inertness.

16. Laboratories

Name SEQUOIA ANALYTICAL LABS  
 Address 2549 MIDDLEFIELD ROAD  
 City REDWOOD CITY State CA Zip 94063  
 State Certification No. 145

17. Chemical Methods to be used for Analyzing Samples

Contaminant Sought	EPA, DHS, or Other Sample Preparation Method Number	EPA, DHS, or Other Analysis Number
WASTE OIL	<p>Soil: • T.O.G. (TOTAL OIL &amp; GREASE) EPA # 503D / 503E</p> <p>• TPH GAS &amp; DIESEL EPA # 5030 / 8015</p> <p>• BTXE EPA # 8020</p> <p>• CLHC (CHLORINATED HYDROCARBONS) EPA # 8010</p> <p>WATER: • T.O.G. EPA # 503A / 503E</p> <p>• T.P.H. GAS &amp; DIESEL EPA # 5030 / 8015</p> <p>• BTXE EPA # 602</p> <p>• CLHC EPA # 601</p>	

18. Submit Site Safety Plan

19. Workman's Compensation: Yes  No

Copy of Certificate enclosed? Yes  No

Name of Insurer HOLTEMANN, ORD & SMITH, INC.

20. Plot Plan submitted? Yes  No

21. Deposit enclosed? Yes  No

22. Please forward to this office the following information within 60 days after receipt of sample results.

- a) Chain of Custody Sheets
- b) Original Signed Laboratory Reports
- c) TSD to Generator copies of wastes shipped and received
- d) Attachment A summarizing laboratory results

I declare that to the best of my knowledge and belief the statements and information provided above are correct and true. I understand that information in addition to that provided above may be needed in order to obtain an approval from the Department of Environmental Health and that no work is to begin on this project until this plan is approved.

I understand that any changes in design, materials or equipment will void this plan if prior approval is not obtained.

I understand that all work performed during this project will be done in compliance with all applicable OSHA (Occupational Safety and Health Administration) requirements concerning personnel and safety.

I will notify the Department of Environmental Health at least two (2) working days (48 hours) after approval of this closure plan in advance to schedule any required inspections. I understand that site and worker safety are solely the responsibility of the property owner or his agent and that this responsibility is not shared nor assumed by the County of Alameda.

Signature of Contractor

Name (please type) \_\_\_\_\_

Signature \_\_\_\_\_

Date \_\_\_\_\_

Signature of Site Owner or Operator

Name (please type) R G Newsome Dist Engr

Signature 

Date 3-10-89

I declare that to the best of my knowledge and belief the statements and information provided above are correct and true. I understand that information in addition to that provided above may be needed in order to obtain an approval from the Department of Environmental Health and that no work is to begin on this project until this plan is approved.

I understand that any changes in design, materials or equipment will void this plan if prior approval is not obtained.

I understand that all work performed during this project will be done in compliance with all applicable OSHA (Occupational Safety and Health Administration) requirements concerning personnel and safety.

I will notify the Department of Environmental Health at least two (2) working days (48 hours) after approval of this closure plan in advance to schedule any required inspections. I understand that site and worker safety are solely the responsibility of the property owner or his agent and that this responsibility is not shared nor assumed by the County of Alameda.

Signature of Contractor

Name (please type) Petroleum Engineering, Inc., Kathleen Lampi

Signature *Kathleen Lampi*

Date March 10, 1989

Signature of Site Owner or Operator

Name (please type) \_\_\_\_\_

Signature \_\_\_\_\_

Date \_\_\_\_\_

NOTES:

1. Any changes in this document must be approved by this Department.
2. Any leaks discovered must be submitted to this office on an underground storage tank unauthorized leak/contamination site report form within 5 days of its discovery.
3. Three (3) copies of this plan must be submitted to this Department. One copy must be at the construction site at all times.
4. After approval of plan, notification of at least two (2) working days (48 hours) must be given to this Department prior to removal of tank(s).
5. A copy of your approved plan must be sent to the landowner.
6. Triple rinse means that:
  - a) Final rinse must contain less than 100 ppm of Gasoline (EPA method 8020 for soil, or EPA method 602 for water) or Diesel (EPA method 418.1). Other methods for halogenated volatile organics (EPA method 8010 for soil, EPA method 601 for water) may be required. The composition of the final rinse must be demonstrated by an original or facsimile report from a laboratory certified for the above analyses.
  - b) Tank interior is shown to be free from deposits or residues upon a visual examination of tank interior.
  - c) Tank should be labelled as "tripled rinsed; laboratory certified analysis available upon request" with the name and address of the contractor.

If all the above requirements cannot be met, the tank must be transported as a hazardous waste.

7. Any cutting into tanks requires local fire department approval.

UNDERGROUND TANK CLOSURE/MODIFICATION PLANS

ATTACHMENT A  
SAMPLING RESULTS

Tank or Area	Contaminant	Location & Depth	Results (specify units)

RE: SITE SAFETY PLAN  
SHELL SERVICE STATION  
9750 GOLD LINKS ROAD  
OAKLAND, CALIFORNIA

SITE SAFETY PLAN - GASOLINE TANK REMOVAL

- 1) For underground gasoline tanks, arrange for disposal of remaining liquid contents with authorized disposal service.
- 2) Drain and flush all piping into tank or appropriate container.
- 3) Remove all flammable liquid from the tank. Use a hand pump to remove the bottom few inches of liquid.
- 4) Uncover tank and disconnect attached piping.
- 5) Prior to complete excavation and tank removal the tanks must be re-purged by the following method.

Preferred method for conditioning tank:

Make vapors inert by adding 15 pounds of dry ice (carbon dioxide per 1000 gallons of tank capacity.

The vapors in the tank will be made inert by adding solid carbon dioxide (dry ice) in the amount of 15 pounds per 1000 gallons of tank capacity. The dry ice should be crushed and distributed evenly over the greatest possible area to secure rapid evaporation. As the dry ice vaporizes, flammable vapors will flow out of the tank and may surround the area. Hence, observe all normal safety precautions regarding flammable vapors. Make sure that all of the dry ice has vaporized.

After the tank has been freed of vapors and prior to moving from the site, plug or cap all holes. Use threaded (boiler) plugs to plug any corrosion leak holes. One tank fitting plug should have a 1/8" vent hole to prevent the tank from being subjected to an excessive pressure differential caused by extreme temperature changes.

- 6) Temporarily plug all tank openings, complete excavation and remove the tank; placing it in a secure location. Block the tank to prevent movement. USE EXTREME CAUTION DURING REMOVAL OPERATION.
- 7) Remove tanks and secure at grade.
- 8) No fiberglass or steel tank shall be reused. Render all tanks useless after removing from site.



- 9) As an added precaution, regardless of condition, the tanks shall be labeled adjacent to the fill opening in legible letters as follows:

"TANKS HAVE CONTAINED FLAMMABLE LIQUIDS  
Not GAS-FREE  
NOT SUITABLE FOR FOOD OR DRINKING WATER"

- 10) Assure tank disposal is in accordance with governing regulations.
- 11) Company Rep. and Contractor shall inspect open excavation for evidence of product leakage.
- 12) The Contractor shall have the following items on site:
1. Fire extinguishers
  2. An LEL meter
  3. A first aid kit
  4. Hard hat and protective clothing for all personnel
  5. Access to an Industrial Hygienist
- 13) When the site is left unattended, surround the excavation with a 6'-0" high removable chain link fence.

#### EMERGENCY PLAN

In the event of an accident, the Contractor shall proceed with the following steps:

- 1) Dial 9-1-1 and provide the following information:

"THERE IS A (FIRE OR DANGEROUS SPILL) AT 2142 EAST 12TH STREET, OAKLAND, CA." If anyone is trapped or needs medical attention, tell the answering dispatcher. Stay on the phone and be prepared to answer any questions concerning the situation.

- 2) Attend any injured persons and direct incoming assistance to them.
- 3) Attempt to extinguish any fire if you can do so safely. Have the extinguisher ready to use in the event of any dangerous spill. Try to contain any spill, or use absorbent on smaller spills.
- 4) Report to arriving emergency response personnel to provide them any information or assistance they may need.
- 5) Notify the following:

Shell Representative, Ray Newsome, (415) 676-1414 X128  
Alameda County Environmental Health, (415) 874-0500  
State Office of Emergency Services, (800) 852-7550 (24 hrs.)

# CERTIFICATE OF INSURANCE

ISSUE DATE (MM/DD/YY)  
02/28/89

**PRODUCER**  
  
HOLTEMANN, ORD & SMITH, INC.  
PO BOX 1868  
NOVATO, CA. 94948

THIS CERTIFICATE IS ISSUED AS A MATTER OF INFORMATION ONLY AND CONFERS NO RIGHTS UPON THE CERTIFICATE HOLDER. THIS CERTIFICATE DOES NOT AMEND, EXTEND OR ALTER THE COVERAGE AFFORDED BY THE POLICIES BELOW.

COMPANIES AFFORDING COVERAGE	
COMPANY LETTER	<b>A</b> COMCO INSURANCE COMPANY
COMPANY LETTER	<b>B</b> REPUBLIC INDEMNITY CO.
COMPANY LETTER	<b>C</b>
COMPANY LETTER	<b>D</b>
COMPANY LETTER	<b>E</b>

**INSURED**  
  
PETROLEUM ENGINEERING  
11 WEST 9TH STREET  
SANTA ROSA, CA. 95401

**COVERAGES**

THIS IS TO CERTIFY THAT POLICIES OF INSURANCE LISTED BELOW HAVE BEEN ISSUED TO THE INSURED NAMED ABOVE FOR THE POLICY PERIOD INDICATED, NOTWITHSTANDING ANY REQUIREMENT, TERM OR CONDITION OF ANY CONTRACT OR OTHER DOCUMENT WITH RESPECT TO WHICH THIS CERTIFICATE MAY BE ISSUED OR MAY PERTAIN. THE INSURANCE AFFORDED BY THE POLICIES DESCRIBED HEREIN IS SUBJECT TO ALL THE TERMS, EXCLUSIONS, AND CONDITIONS OF SUCH POLICIES.

CO. LETTER	TYPE OF INSURANCE	POLICY NUMBER	POLICY EFFECTIVE DATE (MM/DD/YY)	POLICY EXPIRATION DATE (MM/DD/YY)	ALL LIMITS IN THOUSANDS																								
A	<b>GENERAL LIABILITY</b>	100441	03/01/89	03/01/90	<table border="1" style="width: 100%; font-size: x-small;"> <tr><td>GENERAL AGGREGATE</td><td>\$ 2,000</td></tr> <tr><td>PRODUCTS COMMODORS AGGREGATE</td><td>\$ 1,000</td></tr> <tr><td>PERSONAL &amp; ADVERTISING INJURY</td><td>\$ 1,000</td></tr> <tr><td>FAIR LOSS/PREJUDICE</td><td>\$ 1,000</td></tr> <tr><td>FIRE DAMAGE (ANY ONE FIRE)</td><td>\$ 50</td></tr> <tr><td>MEDICAL EXPENSE (ANY ONE PERSON)</td><td>\$ 5</td></tr> </table>	GENERAL AGGREGATE	\$ 2,000	PRODUCTS COMMODORS AGGREGATE	\$ 1,000	PERSONAL & ADVERTISING INJURY	\$ 1,000	FAIR LOSS/PREJUDICE	\$ 1,000	FIRE DAMAGE (ANY ONE FIRE)	\$ 50	MEDICAL EXPENSE (ANY ONE PERSON)	\$ 5												
	GENERAL AGGREGATE					\$ 2,000																							
	PRODUCTS COMMODORS AGGREGATE					\$ 1,000																							
PERSONAL & ADVERTISING INJURY	\$ 1,000																												
FAIR LOSS/PREJUDICE	\$ 1,000																												
FIRE DAMAGE (ANY ONE FIRE)	\$ 50																												
MEDICAL EXPENSE (ANY ONE PERSON)	\$ 5																												
<input checked="" type="checkbox"/> COMMERCIAL GENERAL LIABILITY	<input checked="" type="checkbox"/> CLAIMS MADE <input checked="" type="checkbox"/> BODILY INJURY																												
<input checked="" type="checkbox"/> OWNER'S & CONTRACTORS PROFESSIONAL																													
A	<b>AUTOMOBILE LIABILITY</b>	100441	03/01/89	03/01/90	<table border="1" style="width: 100%; font-size: x-small;"> <tr><td>ANY AUTO</td><td>\$ 1,000</td></tr> <tr><td>ALL OWNED AUTOS</td><td></td></tr> <tr><td>SCHEDULED AUTOS</td><td></td></tr> <tr><td>HIRED AUTOS</td><td></td></tr> <tr><td>NON-OWNED AUTOS</td><td></td></tr> <tr><td>GARAGE LIABILITY</td><td></td></tr> <tr><td>PROPERTY DAMAGE</td><td></td></tr> <tr><td>STATUTORY</td><td></td></tr> <tr><td>BOBLY INJURY PER PERSON</td><td></td></tr> <tr><td>BOBLY INJURY PER ACCIDENT</td><td></td></tr> <tr><td>EACH OCCURRENCE</td><td></td></tr> <tr><td>AGGREGATE</td><td></td></tr> </table>	ANY AUTO	\$ 1,000	ALL OWNED AUTOS		SCHEDULED AUTOS		HIRED AUTOS		NON-OWNED AUTOS		GARAGE LIABILITY		PROPERTY DAMAGE		STATUTORY		BOBLY INJURY PER PERSON		BOBLY INJURY PER ACCIDENT		EACH OCCURRENCE		AGGREGATE	
	ANY AUTO					\$ 1,000																							
	ALL OWNED AUTOS																												
	SCHEDULED AUTOS																												
	HIRED AUTOS																												
NON-OWNED AUTOS																													
GARAGE LIABILITY																													
PROPERTY DAMAGE																													
STATUTORY																													
BOBLY INJURY PER PERSON																													
BOBLY INJURY PER ACCIDENT																													
EACH OCCURRENCE																													
AGGREGATE																													
<input checked="" type="checkbox"/> ANY AUTO																													
<input type="checkbox"/> ALL OWNED AUTOS																													
<input type="checkbox"/> SCHEDULED AUTOS																													
<input checked="" type="checkbox"/> HIRED AUTOS																													
<input checked="" type="checkbox"/> NON-OWNED AUTOS																													
<input type="checkbox"/> GARAGE LIABILITY																													
	<b>EXCESS LIABILITY</b>																												
	<input type="checkbox"/> OTHER THAN UMBRELLA FORM																												
B	<b>WORKERS' COMPENSATION AND EMPLOYERS' LIABILITY</b>	PC988913	01/01/89	01/01/90	<table border="1" style="width: 100%; font-size: x-small;"> <tr><td>STATUTORY</td><td></td></tr> <tr><td>\$ 1,000 (EACH ACCIDENT)</td><td></td></tr> <tr><td>\$ 1,000 (DISEASE-POLICY LIMIT)</td><td></td></tr> <tr><td>\$ 1,000 (DISEASE-EACH EMPLOYEE)</td><td></td></tr> </table>	STATUTORY		\$ 1,000 (EACH ACCIDENT)		\$ 1,000 (DISEASE-POLICY LIMIT)		\$ 1,000 (DISEASE-EACH EMPLOYEE)																	
	STATUTORY																												
\$ 1,000 (EACH ACCIDENT)																													
\$ 1,000 (DISEASE-POLICY LIMIT)																													
\$ 1,000 (DISEASE-EACH EMPLOYEE)																													
<input type="checkbox"/> OTHER																													

**DESCRIPTION OF OPERATIONS/LOCATIONS/VEHICLES/RESTRICTIONS/SPECIAL ITEMS**  
ALL OPERATIONS PERFORMED BY OR FOR THE NAMED INSURED FOR THE CERTIFICATE HOLDER

**CERTIFICATE HOLDER**  
  
ALAMEDA COUNTY DEPARTMENT OF ENVIRONMENTAL HEALTH  
ATTN: DENNIS BYRNE  
80 SWAN WAY RM 200  
OAKLAND, CA. 94621

**CANCELLATION**  
  
SHOULD ANY OF THE ABOVE DESCRIBED POLICIES BE CANCELLED BEFORE THE EXPIRATION DATE THEREOF, THE ISSUING COMPANY WILL ENDEAVOR TO MAIL 30 DAYS WRITTEN NOTICE TO THE CERTIFICATE HOLDER NAMED TO THE LEFT BUT FAILURE TO MAIL SUCH NOTICE SHALL IMPOSE NO OBLIGATION OR LIABILITY OF ANY KIND UPON THE COMPANY, ITS AGENTS OR REPRESENTATIVES.  
AUTHORIZED REPRESENTATIVE: *[Signature]*

CLOSURE PLAN

FACILITY INFORMATION

Facility Name: Shell Oil Service Station  
9750 Golf Links Rd.  
Oakland, California

Owner: Shell Oil Company  
Address: P.O. Box 4023  
Concord, CA 94524

Contact Person: Ray Newsome  
Telephone: (415) 676-1414, Ext. 128

CONTRACTOR INFORMATION

General Contractor: Petroleum Engineering, Inc.  
11 West 9th Street  
Santa Rosa, CA 95401  
(707) 545-0360

Tank Destination: Erickson, Inc.  
Corporate Yard  
255 Parr Blvd.  
Richmond, CA 94801  
(415) 235-1393

Tank Hauler: Crosby Overton  
8430 Amelia Street  
Oakland, CA 94621  
(415) 633-0336

Soil Sample: Kaprealian Engineering  
P.O. Box 913  
Benica, CA 94510  
(707) 746-6915

Soil Analysis Lab.: Sequoia Analytical Labs  
2549 Middlefield Road  
Redwood City, CA 94063  
(415) 364-9222

**ROBERT H. LEE & ASSOCIATES, INC.**  
 900 Larkspur Landing Circle  
 Suite 125  
 LARKSPUR, CALIFORNIA 94939

**LETTER OF TRANSMITTAL**

(415) 461-8890

TO ALAMEDA CO. HEALTH DEPT  
HAZARDOUS MATERIALS DIVISION

DATE	3-16-89	JOB NO.	6839
ATTENTION	MARY CARTER		
RE:	WASTE OIL TANK REMOVAL		
	AT		
	SHELL SERVICE STATION		
	9750 GOLF LINKS RD.		
	OAKLAND, CA 94605		

WE ARE SENDING YOU  Attached  Under separate cover via \_\_\_\_\_ the following items:

- Shop drawings   
  Prints   
  Plans   
  Samples   
  Specifications  
 Copy of letter   
  Change order   
  \_\_\_\_\_

3/17/89

COPIES	DATE	NO.	DESCRIPTION	DEPT. OF HEALTH & HUMAN SERVICES
1		A-1	PLOT PLAN	HAZARDOUS MATERIALS
1			TANK REMOVAL APPLICATION	
1			CLOSURE PLAN	
1			CHECK FOR \$333.00 # 2839	

THESE ARE TRANSMITTED as checked below:

- For approval   
  Approved as submitted   
  Resubmit \_\_\_\_\_ copies for approval  
 For your use   
  Approved as noted   
  Submit \_\_\_\_\_ copies for distribution  
 As requested   
  Returned for corrections   
  Return \_\_\_\_\_ corrected prints  
 For review and comment   
  \_\_\_\_\_  
 FOR BIDS DUE \_\_\_\_\_ 19 \_\_\_\_\_  PRINTS RETURNED AFTER LOAN TO US

REMARKS \_\_\_\_\_  
 \_\_\_\_\_  
PLEASE RETURN A CHECK RECEIPT  
TO OUR OFFICE.

LEE E. SWARDSON

COPY TO \_\_\_\_\_

SIGNED: Lee E. Swardson