

KC

Exxon Company, U.S.A.

QUARTERLY SUMMARY REPORT

January - March 1991

Date: April 8, 1991

RAS #7-0104
1725 Park Street
Alameda, California

04167,326.02

WORK PERFORMED THIS QUARTER

On March 19, 1991, HLA sampled all seven onsite groundwater monitoring wells as part of a continuing monitoring program. HLA also monitored potentiometric surface elevations and checked each well for the presence of free-phase petroleum product on a monthly basis. During March 1991, potentiometric surface elevations ranged from 10.19 to 12.16 feet MSL and a petroleum sheen was encountered in Well MW-2.

QUARTERLY GROUNDWATER SAMPLING (03/19/91) RESULTS: (ug/l)

Well No.	B	T	E	X	TPHg	Historical Trend
MW-1	900	45	390	150	1,400	Unchanged
MW-2	4,500	1,600	2,100	5,500	48,000	Unchanged
MW-3	4,200	2,100	1,100	1,200	18,000	Unchanged
MW-4	1,500	740	620	2,100	11,000	Unchanged
MW-5	2,900	610	580	1,200	17,000	Unchanged
MW-6	11,000	55,000	5,600	28,000	99,000	Unchanged
MW-7	1,600	740	3,400	8,600	44,000	Unchanged

FREE PHASE PRODUCT RECOVERY SUMMARY:

Not Applicable

WORK TO BE PERFORMED NEXT QUARTER:

Activity	Estimated Completion Date
o Continued monthly water-level measurements	Monthly
o Quarterly groundwater sampling	June 1991
o Perform groundwater treatability study	May 1991

- o Complete plans and specifications for groundwater treatment and extraction system



June 1991

WORK TO BE PERFORMED NEXT 12 MONTHS:

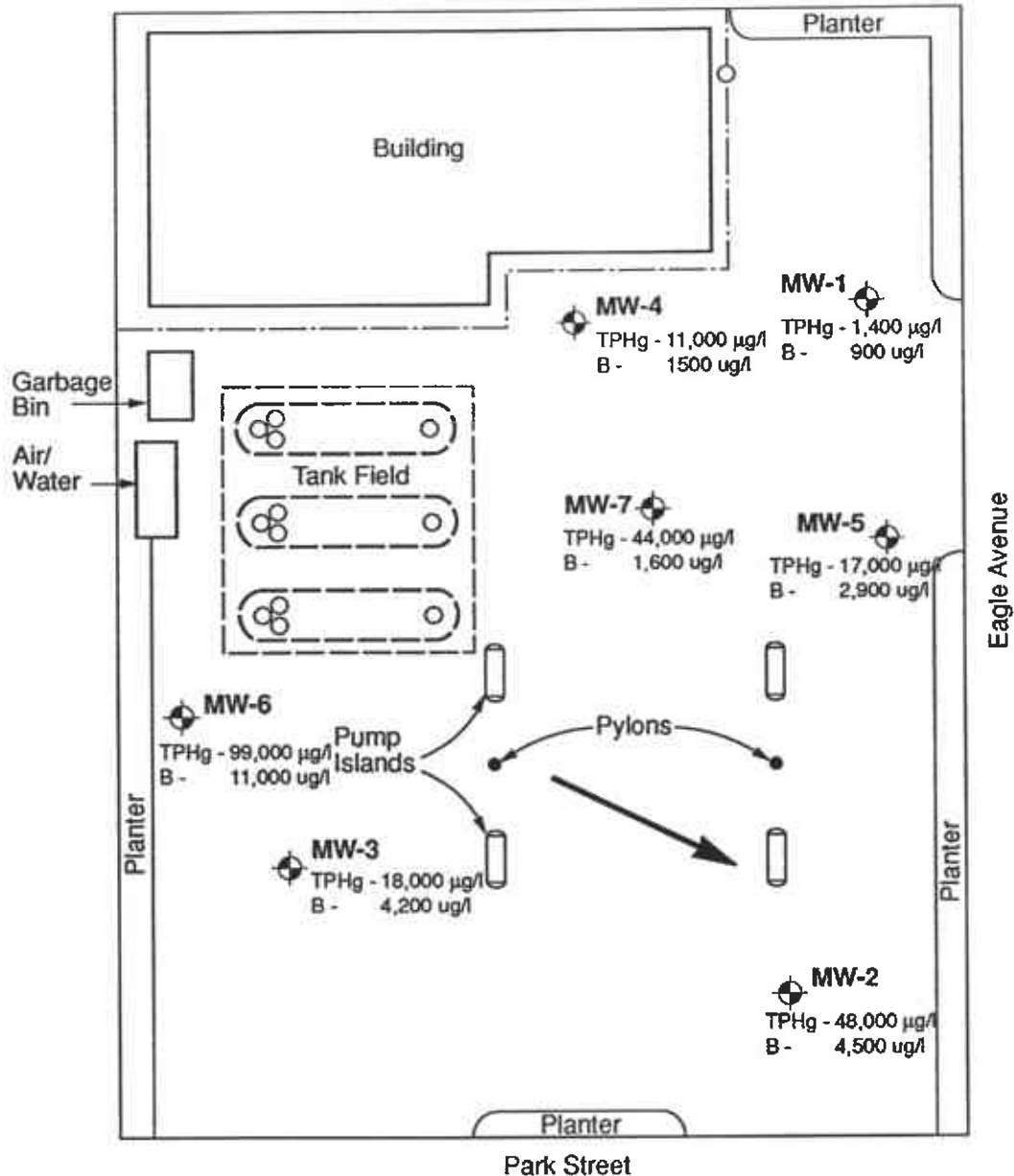
<u>Activity</u>	<u>Estimated Completion Date</u>
o Construct treatment system	September 1991
o Install extraction system	September 1991
o Evaluate and monitor system	Continuously
o Modify system as needed for capture	November 1991
o Install soil biotreatment system	December 1991



EXPLANATION

-  Monitoring Well Location
- TPHg - Concentration of TPH as gasoline in groundwater on 3/19/91 (µg/l)
- B - Concentration of Benzene in groundwater on 3/19/91 (ug/l)
-  Approximate groundwater flow direction

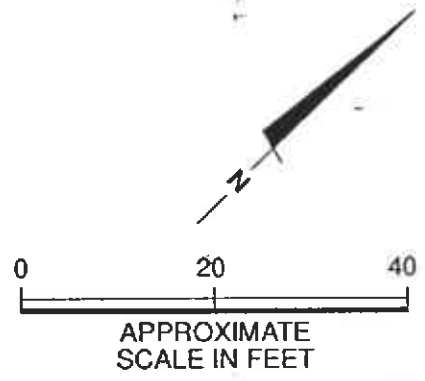

Harding Lawson Associates
 Engineering and Environmental Services

Concentrations of TPH Gasoline and Benzene in Groundwater, March 19, 1991
 Exxon Station #7-0104
 Alameda, California

PLATE
1

DRAWN	JOB NUMBER	APPROVED	DATE	REVISED DATE
LZc	4167,326.02	MJH	4/91	