

April 25, 2011

Mr. Mark Detterman
Alameda County Environmental Health Department
1131 Harbor Bay Parkway, Suite 250
Alameda, CA 94502

RECEIVED

11:22 am, Jun 09, 2011
Alameda County
Environmental Health

SUBJECT: INTERIM REMEDIAL ACTION WORK PLAN CERTIFICATION
County File # RO 387
Mel Senna Brake Service
2301 East 12th Street
Oakland, CA

Dear Mr. Detterman:

P&D Environmental, Inc. has prepared the following document:

- Interim Remedial Action Work Plan dated April 25, 2011 (document 0404.W3).

I declare under penalty of perjury that the contents and conclusions in the document are true and correct to the best of my knowledge.

Should you have any questions, please do not hesitate to contact me at (510) 834-9811.

Sincerely,

J.W. Silveira Realty

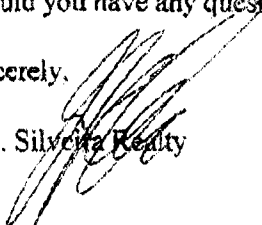

J.W. Silveira

P&D ENVIRONMENTAL, INC.
55 Santa Clara Avenue, Suite 240
Oakland, CA 94610
(510) 658-6916

April 25, 2011
Work Plan 0404.W3

Mr. Mark Detterman
Alameda County Environmental Health
1131 Harbor Bay Parkway, Suite 250
Alameda, CA 94502

SUBJECT: INTERIM REMEDIAL ACTION WORK PLAN
County File # RO 387
Mel Senna Brake Service
2301 East 12th Street
Oakland, CA

Dear Mr. Detterman:

P&D Environmental, Inc. (P&D) is pleased to present this interim remedial action work plan for the subject site. The interim remedial action plan will consist of groundwater extraction at well EW1 and associated vapor extraction feasibility testing. This work plan is written in response to a request set forth in a letter dated December 23, 2010 from the Alameda County Department of Environmental Health (ACDEH) for an interim remedial action plan. A Site Plan showing underground utilities and existing well locations is attached as Figure 1.

All work will be performed under the direct supervision of a professional geologist. This work plan is prepared in accordance with guidelines set forth in the following documents.

- Tri-Regional Board Staff Recommendations for Preliminary Evaluation and Investigation of Underground Tank Sites" dated August 10, 1990 and "Appendix A - Workplan for Initial Subsurface Investigation" dated August 20, 1991,
- Department of Toxic Substances Control (DTSC) "Use of California Human Health Screening Levels (CHHSLs) in Evaluation of Contaminated Properties" dated January, 2005,
- DTSC "Guidance for the Evaluation and Mitigation of Subsurface Vapor Intrusion to Indoor Air" revised February 7, 2005,
- San Francisco Bay Regional Water Quality Control Board (SFRWQCB) "Screening for Environmental Concerns at Sites with Contaminated Soil and Groundwater" dated May 2008,
- DTSC "Vapor Intrusion Mitigation Advisory" revised May 8, 2009.
- DTSC "Advisory - Active Soil Gas Investigations" dated March 3, 2010,

BACKGROUND

The subject site was previously a gas station and vehicle repair facility, and is currently a tire and brake repair facility. The subject site is located in an industrially zoned area and bordered to the northeast by East 12th Street, to the southeast by railroad property, to the northwest by 23rd Avenue and a public park, and to the southwest by a furniture restoration facility.

Review of available reports prepared by others has identified the following historical activities and investigations at the subject site.

- Removal of one gasoline UST, one diesel UST, and two waste oil USTs from December 1990 through March 1991, and excavation of contaminated soil to a depth of approximately 17 to 18 feet below the ground surface (bgs). A total of 16 soil samples were collected from beneath USTs, a total of 6 UST pit sidewall samples were collected, and 2 UST pit water samples were collected. Some of the soil excavated during UST removal was reportedly used to backfill the UST pit.
- Installation of wells MW-1, MW-2, and MW-3 in June, 1991.
- Installation of wells MW-4, MW-5, MW-6, and EW-1, and drilling of two soil borings (B-1 and B-2), and the quarterly monitoring and sampling of wells MW-1, MW-2, and MW-3 from July 1992 through December 1993.
- Weekly and other periodic bailing of wells MW-1, MW-2 and MW-3 at the site during April, May, October and November 1993 as an interim remedial measure to remove separate phase petroleum hydrocarbons from well MW-2 and reduce petroleum hydrocarbon concentrations in the groundwater monitoring wells.
- Collection of groundwater grab samples from boreholes SB-1 through SB-6 on March 31 and April 1, 1999 and quarterly groundwater monitoring well monitoring and sampling from June 1994 through April 1999. Although petroleum hydrocarbons and HVOCs were reported as detected at offsite location SB-6 to the northeast on the opposite side of East 12th Street from the subject site, review of the laboratory report shows that none of the analytes were detected.
- Preparation by Tetra Tech EM, Inc. (Tetra Tech) of a Draft Evaluation of Remedial Alternatives dated February 15, 2001.

The highest concentrations of petroleum hydrocarbons in soil at the site have been detected at depths ranging from 8 to 12 feet bgs. The highest concentrations of petroleum hydrocarbons in groundwater at the site have been detected in well MW-2 (the well where separate phase petroleum hydrocarbons were detected in 1993), MW-3 (located near well MW-2), and in well MW-1 (located at one end of the former UST pit). The highest concentrations of HVOCs detected in groundwater have been at well MW-6, with trichloroethene, cis-1,2-dichloroethene, trans-1,2-dichloroethene and vinyl chloride detected in groundwater. A summary of well construction details for all of the wells at the site is provided in Table 1.

The measured depth to groundwater at the site has typically ranged from approximately 5 to 9 feet. The calculated groundwater flow direction at the site has historically been reported to be predominantly northwesterly. Elevated water levels in wells MW-1 and EW1 are assumed to be associated with localized water level mounding associated with the former UST pits. Table 1

shows that the screened interval for well MW-1 is below the typical range of water levels identified for the site. However, P&D does not recommend that this well be considered for replacement pending evaluation of proposed remediation feasibility test results.

Separate phase hydrocarbons were historically reported to be present in well MW-2, and groundwater sample results have consistently shown the presence of Total Petroleum Hydrocarbons as Gasoline (TPH-G), Total Petroleum Hydrocarbons as Diesel (TPH-D), and benzene, toluene, ethylbenzene, and total xylenes (BTEX) in all of the wells at the site. TPH-G and TPH-D concentrations for all of the wells have almost invariably exceeded 1,000 ug/L during all sampling events, and have shown little evidence of decline since the beginning of monitoring. Groundwater benzene concentrations have ranged up to 5,200 ug/L in well MW-2, and have shown a decline with time for all of the wells. Halogenated Volatile Organic Compounds (HVOCs) have also been historically intermittently detected in groundwater samples at the site, with TCE ranging up to 160 ug/L, and vinyl chloride up to 230 ug/L. MTBE was not detected in any of the groundwater samples.

A review of the laboratory reports for the historical groundwater monitoring well sampling events shows that three of the last four sampling events performed by others where laboratory reports were available for review and the laboratory reported the presence of sheen on the laboratory report identified sheen as present in almost all of the samples.

The Tetra Tech Draft Evaluation of Remedial Alternatives dated February 15, 2001 considered no action, excavation and disposal, in situ chemical treatment, and air sparging as remedial alternatives. Tetra Tech recommended air sparging as the remedial solution. Copies of figures from the Tetra Tech report, including geologic cross section A-A' and a map of gasoline in groundwater are attached with this work plan as Appendix A

Recent activities performed by P&D to augment historical data have included the following.

- Preparation of a review of historical investigation documents for the site that included summaries of historical groundwater level measurements, historical groundwater organic compound and metals concentrations, and historical laboratory report identification of sheen on groundwater (Subsurface Investigation Work Plan (SB-7 Through SB-13 and SG-1 Through SG-5) dated December 16, 2008, document 0404.W1),
- Monitoring and sampling of all of the wells on June 4, 2007.
- Preparation of a Sensitive Receptor Survey Report dated December 8, 2008 (document 0404.R2) for wells located within a 1/2 – mile radius of the subject site.
- Preparation of a Preferential Pathway Survey Report dated December 15, 2008 (document 0404.R3) to identify buried utilities in the vicinity of the subject site that included cross sections showing utility trench and seasonal groundwater depths.
- Subsurface investigation in March 2009 that included collecting groundwater grab samples from seven borings with two of the groundwater grab samples collected at a depth of approximately 50 feet bgs; continuous coring for logging purposes at four of the borings; collection of soil samples from three of the borings; soil conductivity logging at two locations to a depth of 60 feet bgs; and collection of soil gas samples from five locations adjacent to the subject site building at a depth of 3 feet bgs except for SG6 that was collected at a depth of 5 feet bgs (Subsurface Investigation Report (SB7 Through SB13 and

SG1 Through SG6) dated July 7, 2009 (document 0404.R4).

- Monitoring and sampling of all of the wells on February 17, 2011 (document 0404.R7).
- Installation and sampling for four sub-slab soil gas wells in March 2011 (document 0404.R6).

The results of the initial soil gas sampling from the sub-slab soil gas wells showed that all detected soil gas concentrations were below their respective San Francisco Bay Regional Water Quality Control Board (SFRWQCB) May 2008 Table E Environmental Screening Level (ESL) values for both residential and commercial land use, with the exception of naphthalene at one location which was detected at concentrations that exceeded the Table E ESL for both residential and commercial land use.

The results of the February 2011 well sampling show that TPH-G and TPH-D concentrations exceed SFRWQCB May 2008 Table A ESL values for all of the wells, and that benzene concentrations exceed the Table A ESL for all of the wells except MW-4. The sample results also show that MBTE was not detected in any of the wells. Although HVOCs have historically been detected in groundwater in monitoring wells and groundwater grab samples (the highest HVOC concentrations have historically been encountered in the vicinity of the former waste oil UST pit) the only well where HVOCs were detected during the most recent sampling event was EW1.

The location of the former tank pits shown on Figure 1 corresponds with the location of asphalt patch measured at the site for the fuel USTs and a concrete pad for the waste oil USTs. Based on UST pit excavation dimensions provided in the historical UST removal report and the observed location of the asphalt patch for the former UST pit, well EW1 appears to be located in the former UST pit. The subsurface materials identified on the boring log for well EW1 are suspected of being stockpiled materials that were placed back into the pit following UST pit overexcavation.

The locations of geologic cross sections A-A', B-B' and C-C' are also shown on Figure 1. Geologic cross section A-A' is attached in Appendix A, and geologic cross sections B-B' and C-C' are attached as Figure 2. Geologic cross sections B-B' and C-C' include information obtained from historical reports documenting soil sample collection associated with the removal of the USTs and the drilling of borings B1, B2, EW1, MW-1 and MW-6.

TPH-D, TPH-G, and benzene soil sample concentrations for samples collected from UST pits and soil borings are shown on cross sections B-B' and C-C' in Figures 3, 4 and 5, respectively. The total depth of the UST pits, the dimensions of the area excavated in the vicinity of the former diesel UST, and the UST pit soil samples shown on the geologic cross sections are approximated based on information provided in the Epigene 1993 tank closure summary report.

Although the UST pit sidewall and pit bottom samples show that the majority of petroleum hydrocarbon mass appears to have been removed from the fuel UST pit, the soil samples from borings B1 and B2 (these boreholes were drilled after the UST pit was backfilled with soil that had been excavated from the fuel UST pit) at a depth of 10 feet bgs show that soil with elevated concentrations of TPH-G and TPH-D was placed back into the fuel UST pit. The MW-1

borehole soil samples show that substantial horizontal attenuation occurred with residual sidewall petroleum concentrations at the east end of the former diesel UST.

TPH-D, TPH-G, and benzene groundwater concentrations for the most recent well sampling event are shown in Figures 6, 7 and 8, respectively. Review of the figures shows that the TPH-D and benzene concentrations at wells MW-2 and MW-3 (located immediately downgradient of and approximately 15 feet from the former UST pits) are approximately one order of magnitude greater than the concentrations encountered in wells MW-4 and MW-5 (located immediately downgradient of wells MW-2 and MW-3 and approximately 50 feet from the former UST pits). The rate of TPH-G groundwater concentration attenuation is approximately a factor of 2 to 3 between wells MW-2 and MW-3 and wells MW-4 and MW-5.

The isoconcentration contours shown on Figures 6 through 8 were prepared with data that included borehole groundwater grab sample results which could be positively biased due to sorption of petroleum to sediments in the borehole groundwater grab samples. For this reason the isoconcentration contours are assumed to provide a conservative approximation of the extent of impact to groundwater. Review of TPH-D and TPH-G groundwater concentrations in Figures 6 and 7 shows that the areas of elevated groundwater petroleum concentrations are immediately downgradient of the former UST pits. Review of geologic cross section A-A' in Appendix A shows that the subsurface conditions downgradient of the site are identified as clay with the exception of clayey sand at location SB-4 between the depths of 17 and 19 feet bgs.

Figures 6 through 8 show the presence of a water pipe in 23rd Avenue immediately downgradient of the former UST pits and adjacent to the sidewalk. Based on discussions with East Bay Municipal Utility District (EBMUD) personnel, the pipe is considered a high pressure water main, and excavation in the vicinity of this water pipe is undesirable based on service disruption concerns. Based on excavation limitations in the immediate downgradient vicinity of the former UST pits, the historical presence of separate phase petroleum hydrocarbons in well MW-2, the presence of elevated petroleum hydrocarbon concentrations in wells located immediately downgradient of the former UST pits, and the continued presence of HVOCs in well EW1, P&D recommends that a groundwater extraction feasibility test be performed in conjunction with a soil vapor extraction feasibility test to verify that groundwater and soil gas extraction in the vicinity of the former UST pits is a feasible remedial solution.

SCOPE OF WORK

P&D will perform the following tasks.

- Permitting.
- Health and safety plan preparation and mark drilling locations with white paint.
- Install four permanent sub-slab vapor sampling probes.
- Soil gas sample collection.
- Arrange for soil gas sample analysis.
- Report preparation.

Each of these is discussed below in detail.

Permitting

A permit will be obtained from EBMUD for discharge of groundwater pumped from well EW1 to the sanitary sewer.

Health and Safety Plan Preparation

A health and safety plan will be prepared for the scope of work identified in this work plan. Notification of the scheduled dates of interim remedial action implementation will also be provided to the ACDEH.

Groundwater Extraction Feasibility Testing

To evaluate flow rates and drawdown, groundwater will be pumped from well EW1 for a minimum of five days. Pressure transducers will be placed into the extracting well (EW1) and the surrounding wells (MW-1 through MW-6) five days prior to the pump test to identify pre-test trends in water level changes. While pumping from well EW1, water levels will be monitored in the extracting well and wells MW-1 through MW-6 using the pressure transducers. The pumping rate will be determined based on drawdown and recharge rates observed during well sampling. Following determination of the discharge rate from the extraction well, pumping will continue until steady-state conditions are observed in the surrounding observation wells (MW-1 through MW-6), at which time a vapor extraction feasibility test will be performed (see below). Water pumped from the well will be stored onsite in a tank pending characterization and proper disposal, or will be discharged to either the storm drain or sanitary sewer following receipt of appropriate permits.

At the conclusion of the pump test (after completion of the vapor extraction feasibility test), a water sample will be collected from well EW1 using a clean disposable polypropylene bailer. The water samples will be transferred to 40-milliliter glass VOA vials and 1-liter amber glass bottles that will be sealed with Teflon-lined screw caps. The VOA vials will be overturned and tapped to ensure that no air bubbles are present. The VOA vials and bottles will be transferred to a cooler with ice, pending delivery to the laboratory. Chain of custody documentation will accompany the samples to the laboratory.

Following sample collection from well EW1 at the conclusion of the pump test the pump in well EW1 will be shut off and the water level recovery in the wells will also be recorded with the pressure transducers.

Soil Vapor Extraction Feasibility Testing

Following verification of dewatering feasibility at the site, a vapor extraction pilot test will be performed. All necessary notifications and permits will be obtained from the BAAQMD. A trailer-mounted positive displacement blower capable of generating 20 inches of Mercury vacuum with an unburdened flow rate of 400 cubic feet per minute or a trailer-mounted liquid ring blower capable of generating 28 inches of Mercury vacuum with an unburdened flow rate of 400 cubic feet per

minute will be used to evaluate vapor extraction feasibility at the site. Granular activated carbon or thermal oxidation will be used as the air pollution control device.

Following identification of steady-state drawdown conditions in the observation wells associated with the groundwater extraction feasibility test, vacuum monitoring ports will be installed at the top of each of wells MW-1 through MW-6 and a vapor extraction step test with four different vacuums will be performed at well EW1 for one day. Each step will be performed for two hours. During each step, the following information and associated time of measurement will be recorded.

- Air flow rate at the extracting well. Air flow rates will be measured using a hot wire anemometer at approximately one half hour intervals during each step.
- Air temperature. Air temperature from the extracting well will be monitored when air flow rates are measured.
- PID values at the extracting well. A field PID will be used to evaluate organic vapor concentrations at the beginning of each step and at approximately one half hour intervals during each step.
- Vacuum at all wells. Vacuum will be measured at approximately 15 minute intervals using magnehelic gages and verified with a monometer for all wells where vapor extraction is not taking place.
- Vacuum at the blower. The vacuum at the blower will recorded at the beginning and end of each step using a vacuum gage.

One air sample will be collected from a sampling port located at the inlet to the blower at the end of the step test using a 1-liter Summa canister, and also with a sorbent tube. The Summa canister will be stored in a box and the sorbent tube will be stored in a cooler with ice pending delivery to the laboratory. Chain of custody documentation will accompany the sample to the laboratory. Once the pilot test is completed, the blower will be shut off and vacuum will be monitored at all of the wells to determine the rate of vacuum decay. Atmospheric barometric pressure and ambient air temperature at the site will be obtained from a local weather station for the time period of the pilot test and for the two weeks preceding the feasibility test.

Arrange for Sample Analysis

The groundwater samples collected at the end of the groundwater pump tests will be analyzed at McCampbell Analytical, Inc (McCampbell) of Pittsburg, California for TPH Multi-Range (TPH as Gasoline, TPH as Diesel, and TPH as Bunker Oil) using Modified EPA Method 8015, and for MBTEX and HVOCs using EPA Method 8260B. McCampbell is a State-accredited hazardous waste testing laboratory.

The soil gas Summa canister sample collected at the end of the vapor extraction pilot test will be analyzed at Air Toxics Limited of Folsom California for TPH-G using EPA Method TO-3 and for MBTEX and HVOCs detected at the site by EPA Method TO-15. The soil gas sorbent tube sample collected at the end of the vapor extraction pilot test will be analyzed at Air Toxics Limited of Folsom California for naphthalene using EPA Method TO-17.

April 25, 2011
Work Plan 0404.W3

Report Preparation

Upon receipt of the laboratory analytical results, a report will be prepared. The report will document the feasibility test procedures and results. The report will include a site plan showing the well locations, copies of field data sheets generated during the remediation feasibility test, copies of the laboratory reports, tables summarizing the sample results, recommendations based on the sample results, and the stamp of a professional geologist. The report will also include graphs showing weather conditions (temperature, wind direction, wind speed, barometric pressure, and precipitation) for a weather station located in the site vicinity for the feasibility test dates and for the two weeks preceding each of the feasibility tests.

Should you have any questions, please do not hesitate to contact us at (510) 658-6916.

Sincerely,

P&D Environmental, Inc.

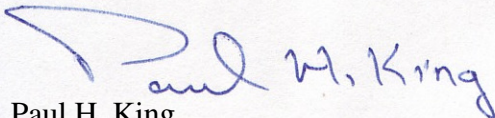

Paul H. King
California Professional Geologist #5901
Expires: 12/31/11



Attachments:

Table 1 – Well Construction Detail Summary

Figure 1 – Site Vicinity Map Showing Well and Geologic Cross Section Locations

Figure 2 – Geologic Cross Sections B-B' and C'C'

Figure 3 – Geologic Cross Sections B-B' and C'C' Showing TPH-D in Soil

Figure 4 – Geologic Cross Sections B-B' and C'C' Showing TPH-G in Soil

Figure 5 – Geologic Cross Sections B-B' and C'C' Showing Benzene in Soil

Figure 6 – Site Vicinity Map Showing TPH-D in Groundwater

Figure 7 – Site Vicinity Map Showing TPH-G in Groundwater

Figure 8 – Site Vicinity Map Showing Benzene in Groundwater

Appendix A – Selected Portions of Tetra Tech EM, Inc. February 15, 2001 Draft Evaluation of Remedial Alternatives

PHK/ml
0404.W3

TABLES

TABLE 1

Well Construction Detail Summary

Well No.	Total Depth (feet)	Screened Interval (feet)	Filter Pack Interval (feet)	Diameter (inches)	NOTES
MW-1	28	13 to 28	12 to 28	2	
MW-2	19	4 to 19	5 to 19	2	Bentonite seal covers 1-foot of screened interval.
MW-3	19	4 to 19	5 to 19	2	Bentonite seal covers 1-foot of screened interval.
MW-4	20	8 to 20	6 to 20	2	
MW-5	20	8 to 20	6 to 20	2	
MW-6	20	8 to 20	6 to 20	2	
EW1	30	8 to 30	6 to 30	4	

FIGURES

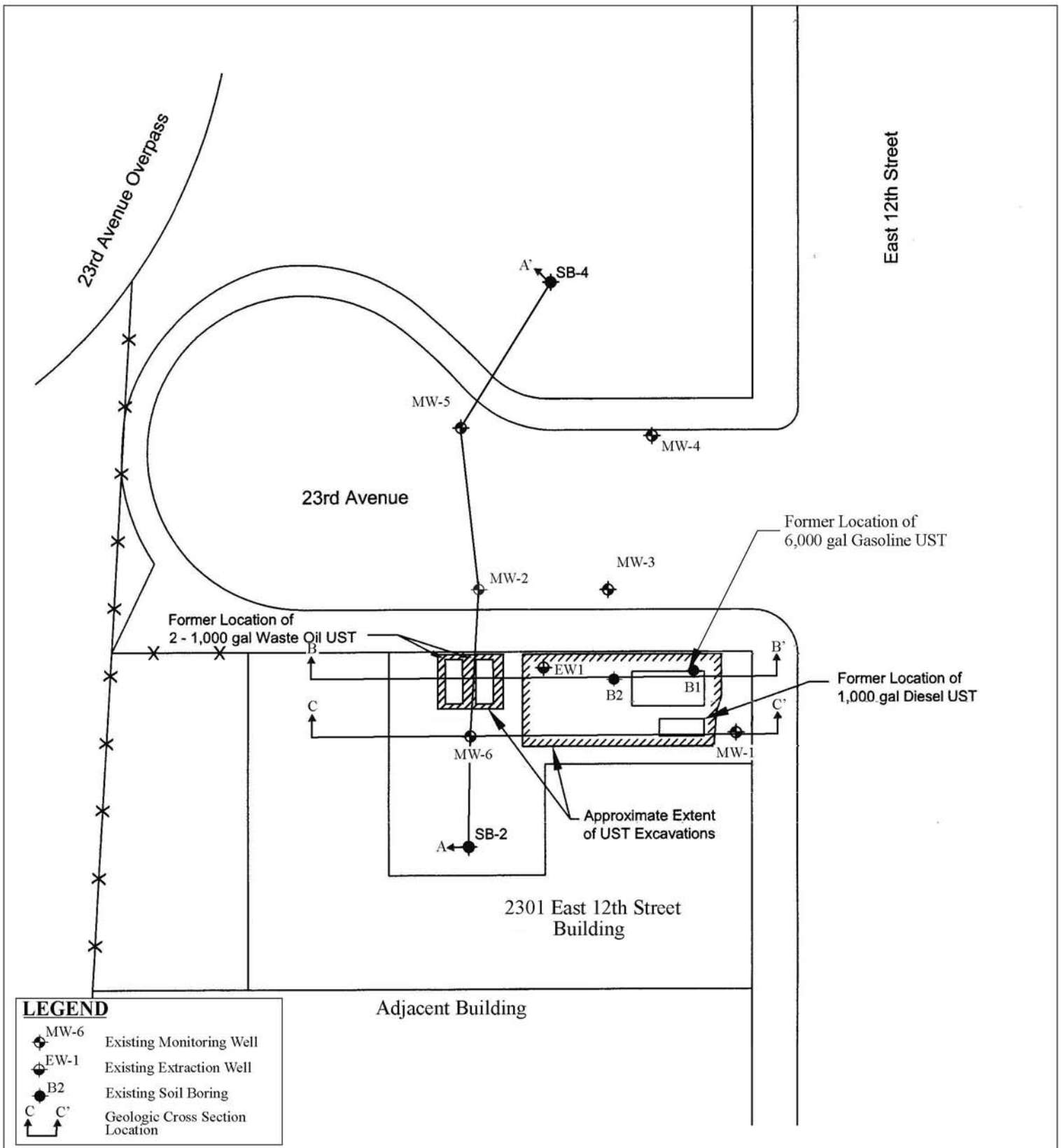

Figure 1
 Site Vicinity Map Showing Well and Geologic Cross Section Locations
 Mel Senna Brake Service
 2301 East 12th Street
 Oakland, California



Base Map From:
 Tetra Tech EM, Inc., Draft Summary
 Reports for Additional Site
 Characterization Work, dated
 November 10, 1999

P&D Environmental, Inc.
 55 Santa Clara Ave., Suite 240
 Oakland, CA 94610



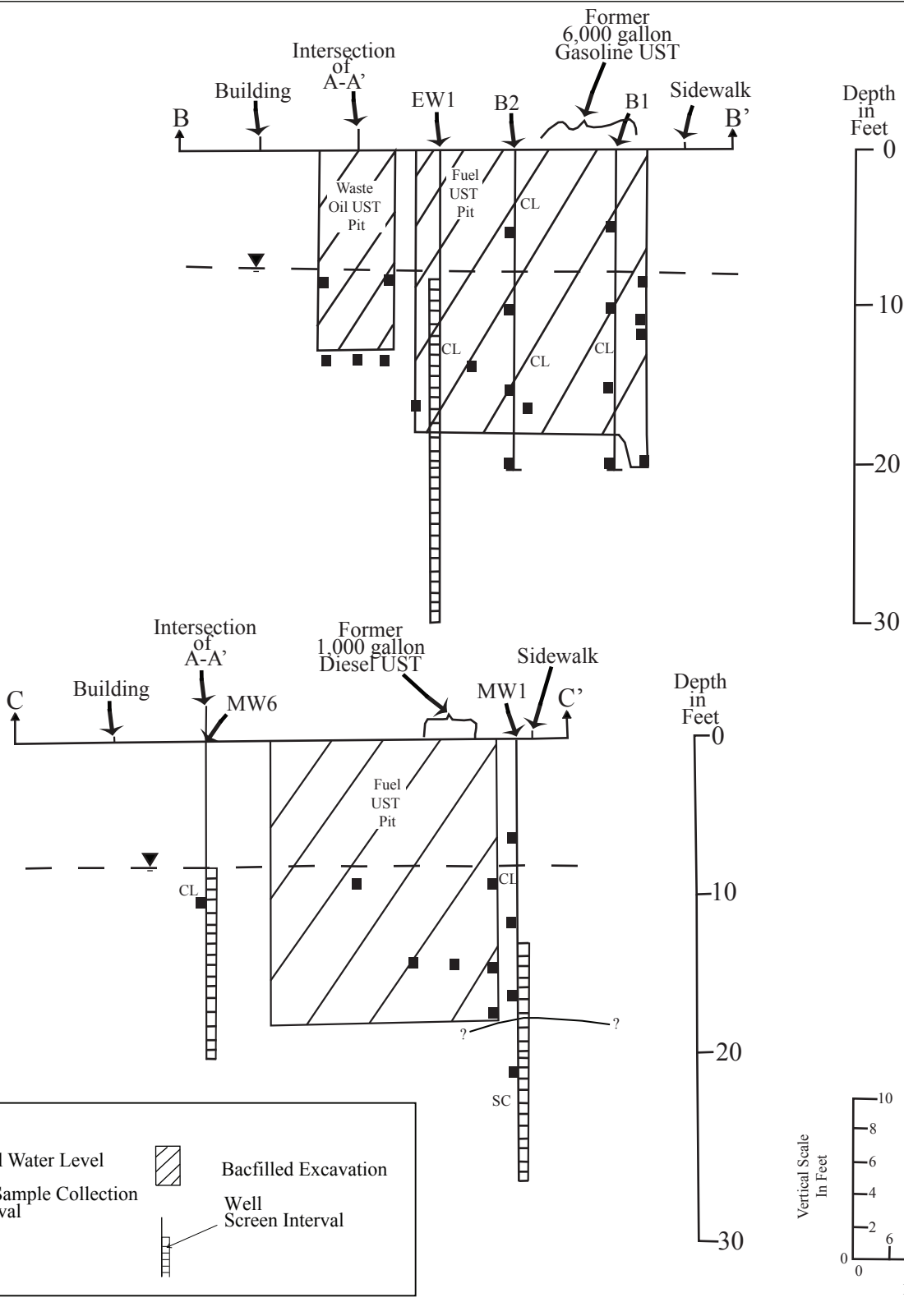

Figure 2
 Geologic Cross Sections B-B' and C-C'
 Mel Senna Brake Service
 2301 East 12th Street
 Oakland, California

P&D Environmental, Inc.
 55 Santa Clara Ave., Suite 240
 Oakland, CA 94610

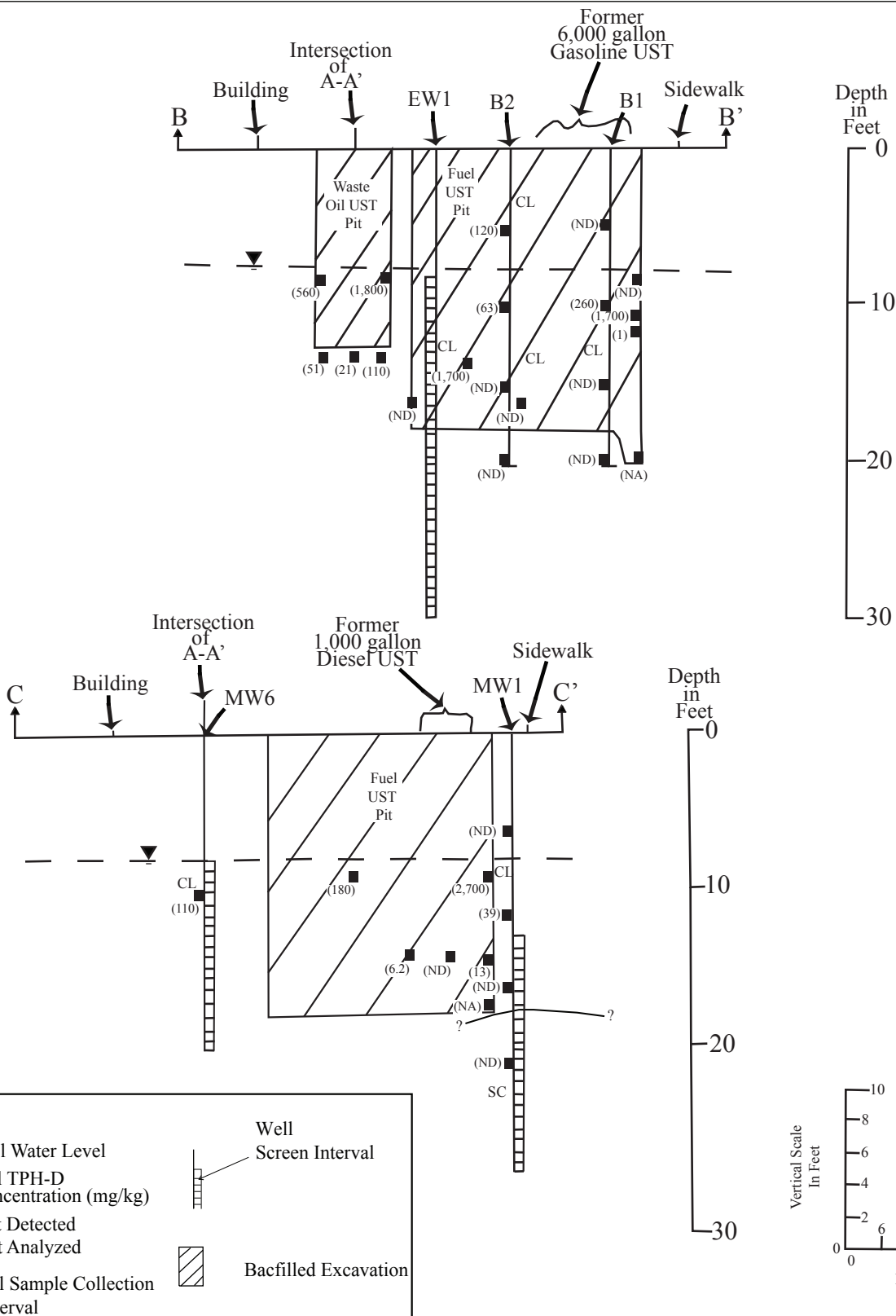

Figure 3
Geologic Cross Sections B-B' and C-C' Showing TPH-D in Soil
Mel Senna Brake Service
2301 East 12th Street
Oakland, California

P&D Environmental, Inc.
55 Santa Clara Ave., Suite 240
Oakland, CA 94610

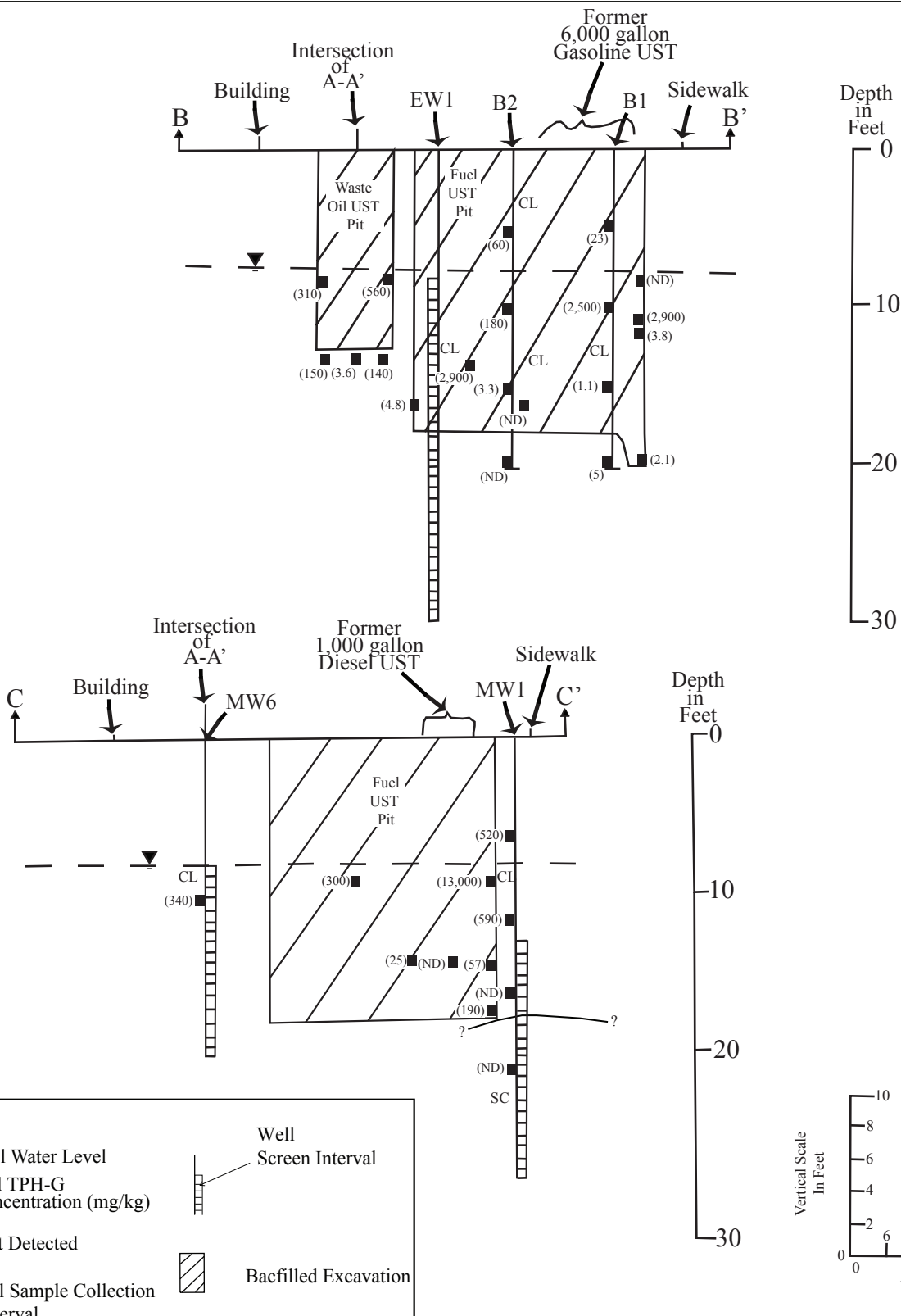
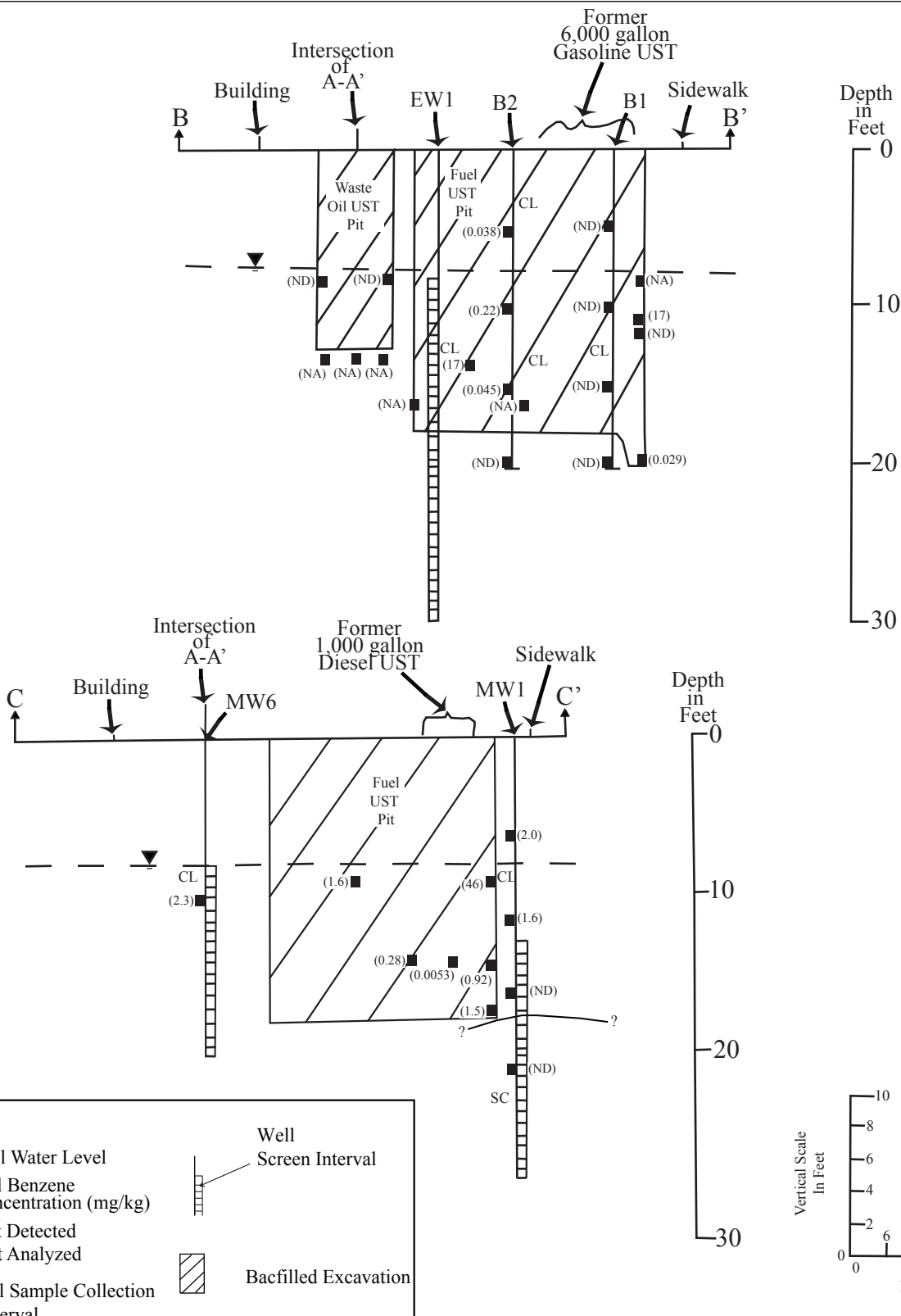
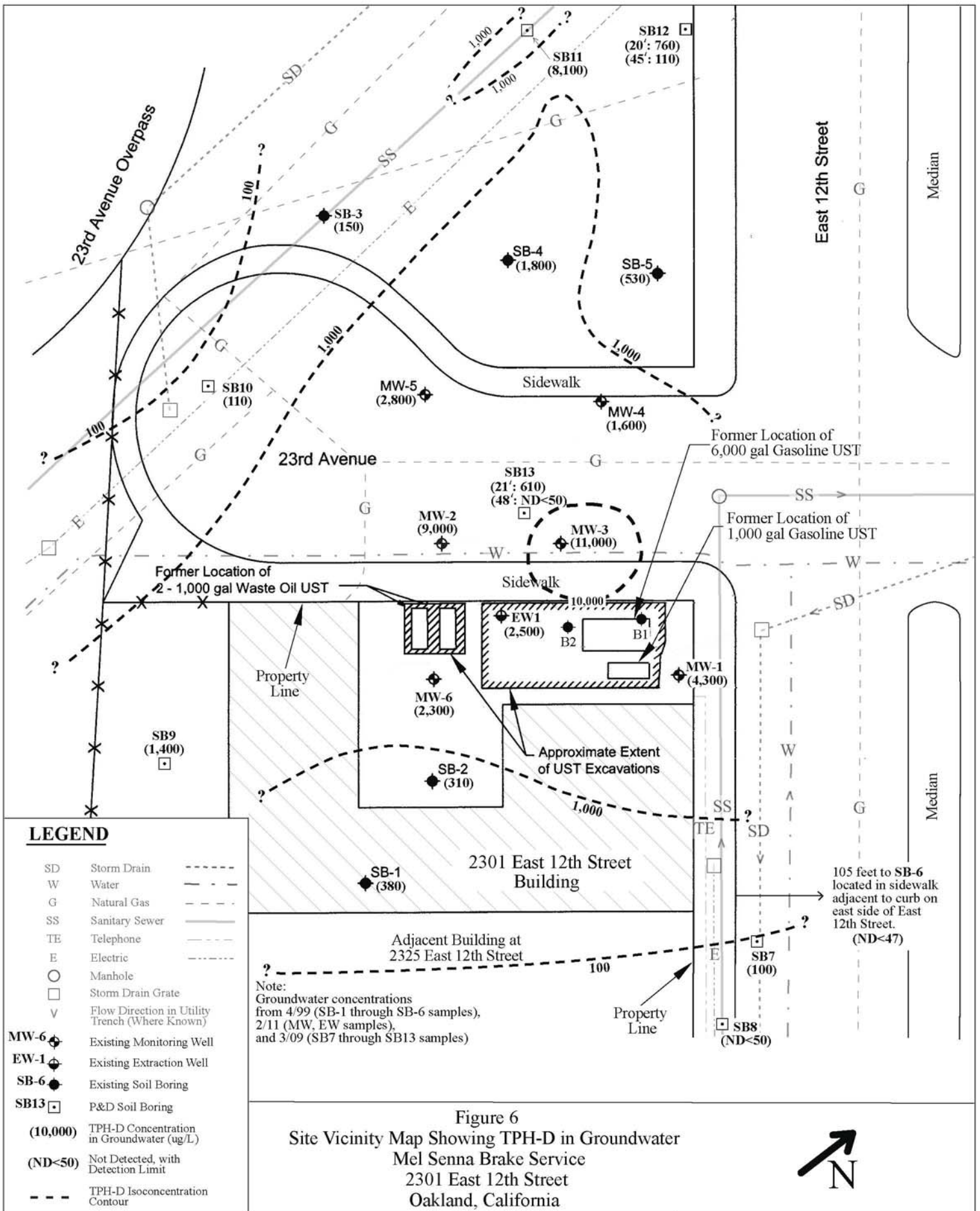

Figure 4
 Geologic Cross Sections B-B' and C-C' Showing TPH-G in Soil
 Mel Senna Brake Service
 2301 East 12th Street
 Oakland, California

P&D Environmental, Inc.
 55 Santa Clara Ave., Suite 240
 Oakland, CA 94610





Base Map From:
Tetra Tech EM, Inc., Draft Summary Reports for Additional Site Characterization Work, dated 11/10/99

P&D Environmental, Inc.
55 Santa Clara Ave., Suite 240
Oakland, CA 94610

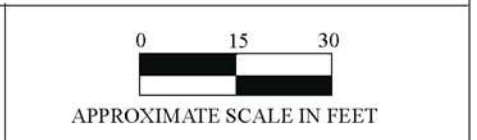

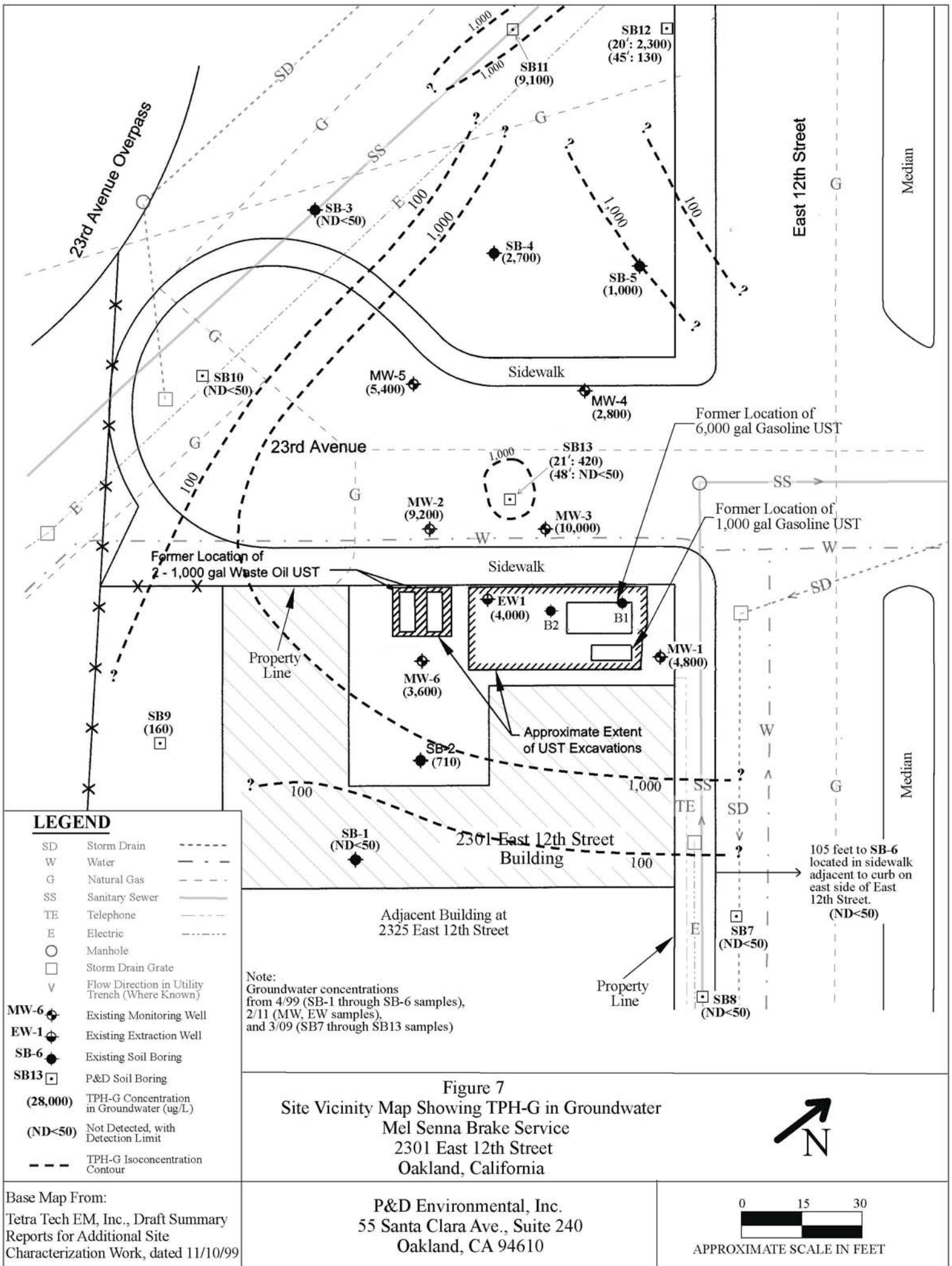

LEGEND

- SD Storm Drain -----
- W Water -----
- G Natural Gas -----
- SS Sanitary Sewer -----
- TE Telephone -----
- E Electric -----
- Manhole
- Storm Drain Grate
- ∇ Flow Direction in Utility Trench (Where Known)
- MW-6 Existing Monitoring Well
- EW-1 Existing Extraction Well
- SB-6 Existing Soil Boring
- SB13 P&D Soil Boring
- (28,000) TPH-G Concentration in Groundwater (ug/L)
- (ND<50) Not Detected, with Detection Limit
- - - - - TPH-G Isoconcentration Contour

Note:
Groundwater concentrations from 4/99 (SB-1 through SB-6 samples), 2/11 (MW, EW samples), and 3/09 (SB7 through SB13 samples)

Figure 7
Site Vicinity Map Showing TPH-G in Groundwater
Mel Senna Brake Service
2301 East 12th Street
Oakland, California



Base Map From:
Tetra Tech EM, Inc., Draft Summary Reports for Additional Site Characterization Work, dated 11/10/99

P&D Environmental, Inc.
55 Santa Clara Ave., Suite 240
Oakland, CA 94610

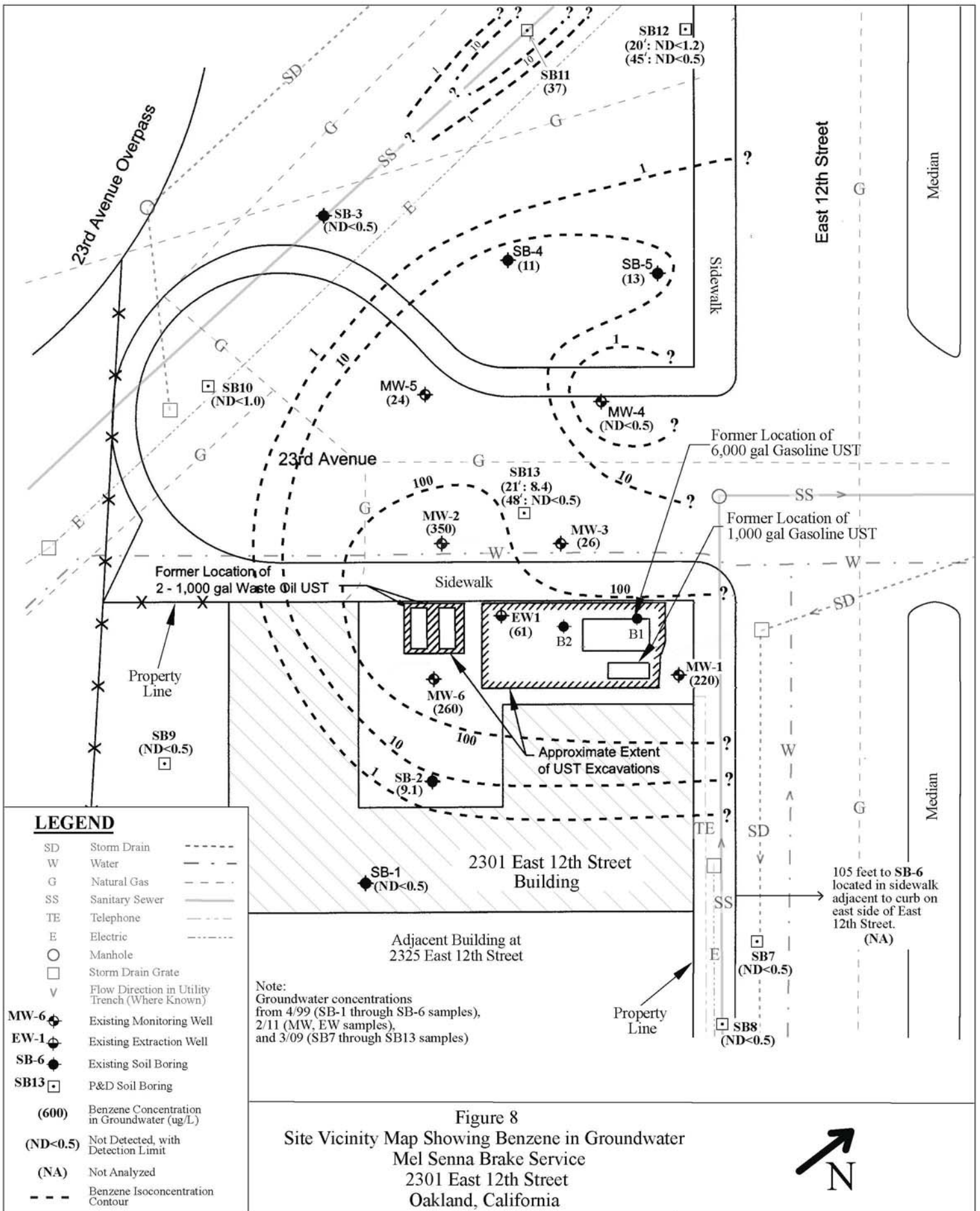

LEGEND

SD	Storm Drain	-----
W	Water	-----
G	Natural Gas	-----
SS	Sanitary Sewer	-----
TE	Telephone	-----
E	Electric	-----
○	Manhole	
□	Storm Drain Grate	
∇	Flow Direction in Utility Trench (Where Known)	
MW-6	Existing Monitoring Well	
EW-1	Existing Extraction Well	
SB-6	Existing Soil Boring	
SB13	P&D Soil Boring	
(600)	Benzene Concentration in Groundwater (ug/L)	
(ND<0.5)	Not Detected, with Detection Limit	
(NA)	Not Analyzed	
- - -	Benzene Isoconcentration Contour	

Note:
Groundwater concentrations from 4/99 (SB-1 through SB-6 samples), 2/11 (MW, EW samples), and 3/09 (SB7 through SB13 samples)

Figure 8
Site Vicinity Map Showing Benzene in Groundwater
Mel Senna Brake Service
2301 East 12th Street
Oakland, California

Base Map From:
Tetra Tech EM, Inc., Draft Summary Reports for Additional Site Characterization Work, dated 11/10/99

P&D Environmental, Inc.
55 Santa Clara Ave., Suite 240
Oakland, CA 94610

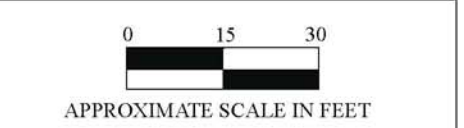

APPENDIX A

**Selected Portions of Tetra Tech EM, Inc. February 15, 2001
Draft Evaluation of Remedial Alternatives**



Tetra Tech EM Inc.

135 Main Street, Suite 1800 ♦ San Francisco, CA 94105 ♦ (415) 543-4880 ♦ FAX (415) 543-5480

February 15, 2001

R0387

* 71

Barney Chan
Hazardous Materials Specialist
Alameda County Health Care Services Agency
Environmental Health Services
1131 Harbor Bay Parkway, Suite 250
Alameda, CA 94502-6577

**Subject: Submittal of Draft Evaluation of Remedial Alternatives for the
J.W. Silveira Company Underground Storage Tank Site at
2301 East 12th Street in Oakland, California**

Dear Mr.Chan:

Enclosed is one copy of the draft Evaluation of Remedial Alternatives for the J. W. Silveira Company underground storage tank site located at 2301 East 12th Street in Oakland, California. I believe that we have developed a feasible remediation plan for the site using a combination of soil excavation and air sparging. As we only arrived at the idea for this plan within the past few days, we have not yet had the opportunity to discuss it with you. Thus, your comments on this document, and on the proposed remedial alternatives would be appreciated.

The sections of this report in which cleanup goals and general response actions are presented (Sections 3.0 and 4.0) are not as all-encompassing as a true feasibility study would present them. This is because we have not conducted a risk assessment or a groundwater beneficial use assessment for the site to date. Any comments you may have on these two sections in particular would be very helpful.

After receipt of comments from you, Tetra Tech will address them and submit a hard copy of the final report to you within 5 working days. The final copy of the report will include a registered geologist's stamp and signature.

Thank you for your assistance. Please call me at (415) 222-8316 with any questions.

Sincerely,

for Hal Dawson
Project Manager/Geologist

cc: J.W. Silveira Company
Shapiro Buchman Provine & Patton LLP
File

**DRAFT
EVALUATION OF REMEDIAL ALTERNATIVES**

**UNDERGROUND STORAGE TANK SITE
2301 EAST 12TH STREET
OAKLAND, CALIFORNIA**

FEBRUARY 15, 2001

Prepared For

**J.W. SILVEIRA COMPANY
499 Embarcadero Street
Oakland, California 94606**

Prepared By

**TETRA TECH EM Inc.
135 Main Street, Suite 1800
San Francisco, California 94105**

Hal Dawson, TtEMI Project Manager

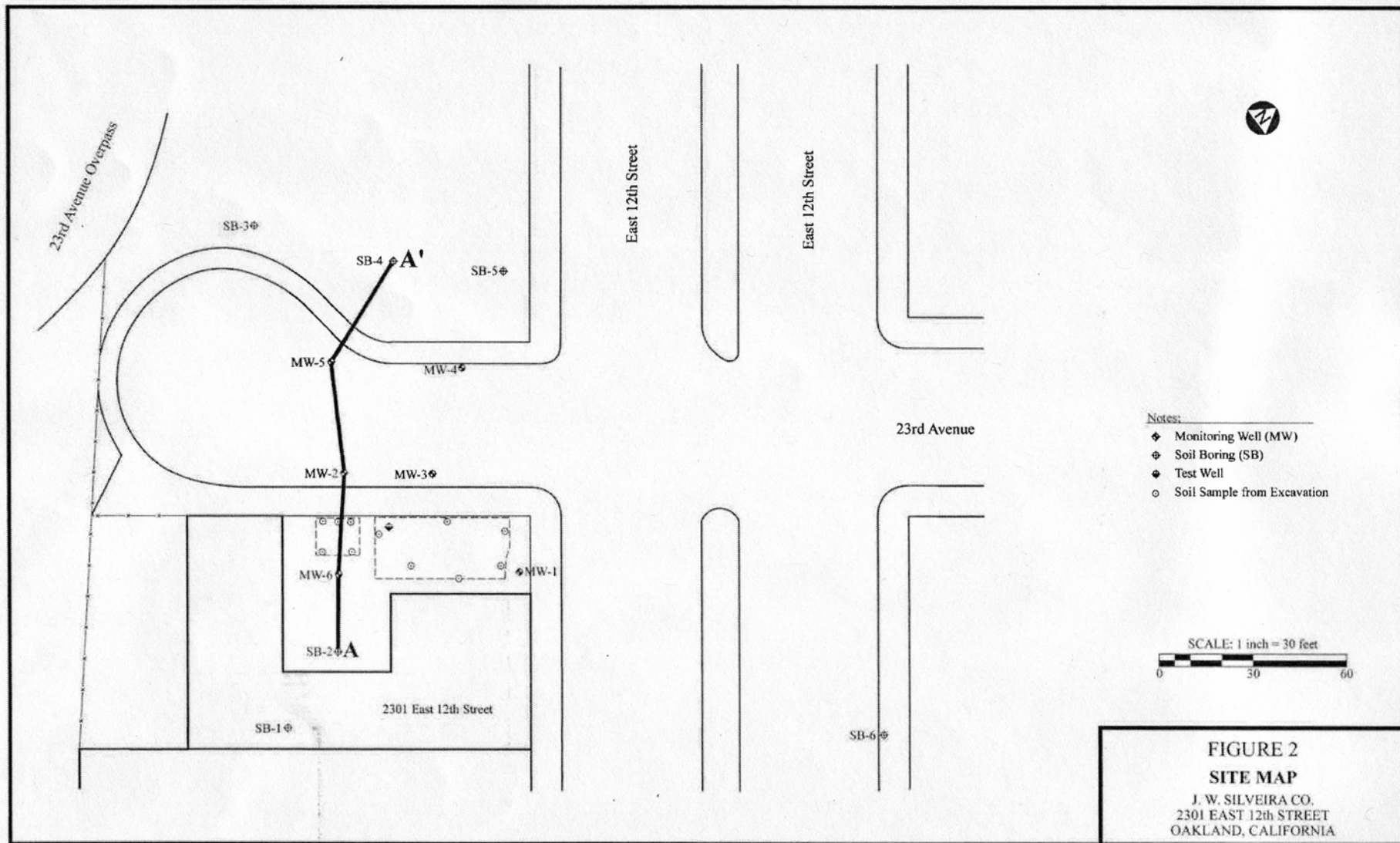

- Notes:
- ◆ Monitoring Well (MW)
 - ◆ Soil Boring (SB)
 - Test Well
 - Soil Sample from Excavation

SCALE: 1 inch = 30 feet
 0 30 60

FIGURE 2
SITE MAP
 J. W. SILVEIRA CO.
 2301 EAST 12th STREET
 OAKLAND, CALIFORNIA

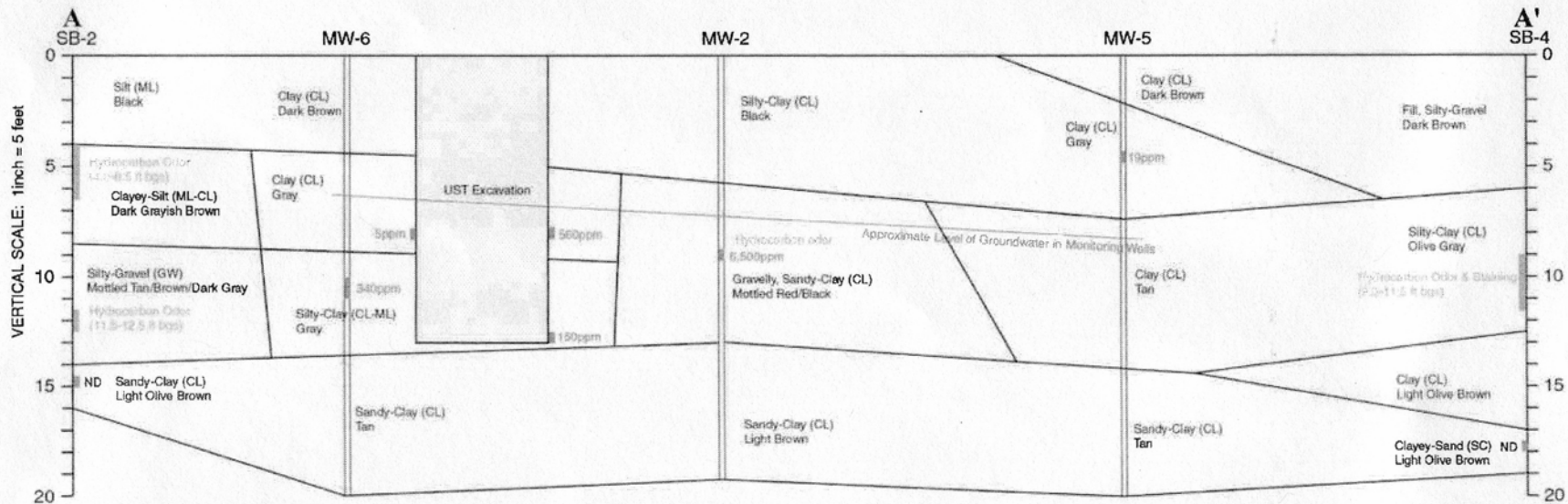

**FIGURE 3
 CROSS SECTION A-A'
 GASOLINE IN SOIL**

J. W. SILVEIRA CO.
 2301 EAST 12th STREET
 OAKLAND, CALIFORNIA