



**CONESTOGA-ROVERS
& ASSOCIATES**

5900 Hollis Street, Suite A
Emeryville, California 94608
Telephone: (510) 420-0700 Fax: (510) 420-9170
www.CRAworld.com

TRANSMITTAL

DATE: April 11, 2014 REFERENCE NO.: 060061
 PROJECT NAME: Chevron 060061
 TO: Mr. Mark Detterman ACEH RO#0342
Alameda County Environmental Health Services
1131 Harbor Bay Parkway, Suite 250
Alameda, California 94502-6577

Please find enclosed: Draft Final
 Originals Other
 Prints
 Sent via: Mail Same Day Courier
 Overnight Courier Other Alameda County FTP Upload and GeoTracker

QUANTITY	DESCRIPTION
1	Conceptual Site Model and Closure Request

As Requested For Review and Comment
 For Your Use _____

COMMENTS:

Please contact Nathan Lee at (925)849-1003 or nlee@croworld.com with any questions or comments regarding the contents of this report.

Copy to: Ms. Alexis Fischer (Chevron)

Completed by: Nathan Lee
[Please Print]

Signed: *Nathan Lee*

Filing: **Correspondence File**



Alexis Fischer
Project Manager
Marketing Business Unit

**Chevron Environmental
Management Company**
6101 Bollinger Canyon Road
San Ramon, CA 94583
Tel (925)790-6441
afischer@chevron.com

Alameda County Health Care Services
1131 Harbor Bay Parkway, Suite 250
Alameda, CA 94502-6577

Re: Chevron Service Station No. 94800
1700 Castro Street
Oakland, CA

I have reviewed the attached report entitled *Conceptual Site Model and Closure Request*.

I agree with the conclusions and recommendations presented in the referenced report. The information in this report is accurate to the best of my knowledge and all local Agency/Regional Board guidelines have been followed. This report was prepared by Conestoga-Rovers & Associates, upon whose assistance and advice I have relied.

This letter is submitted pursuant to the requirements of California Water Code Section 13267(b)(1) and the regulating implementation entitled Appendix A pertaining thereto.

I declare under penalty of perjury that the foregoing is true and correct to the best of my knowledge.

Sincerely,

A handwritten signature in blue ink that reads "Alexis Fischer".

Alexis Fischer
Project Manager

Attachment: Conceptual Site Model and Closure Request



CONCEPTUAL SITE MODEL AND CLOSURE REQUEST

**CHEVRON SERVICE STATION 94800
1700 CASTRO STREET
OAKLAND, CALIFORNIA
ACEH FUEL LEAK CASE NO. RO0342**

Prepared For:

**Mr. Mark Detterman
Alameda County Environmental Health Services
1131 Harbor Bay Parkway, Suite 250
Alameda, California 94502-6557**

**Prepared by:
Conestoga-Rovers
& Associates**

5900 Hollis Street, Suite A
Emeryville, California
U.S.A. 94608

Office: (510) 420-0700
Fax: (510) 420-9170

web:
<http://www.CRAworld.com>

APRIL 11, 2014
REF. NO. 060061 (12)
This report is printed on recycled paper



RECEIVED

By Alameda County Environmental Health at 2:16 pm, Apr 11, 2014

CONCEPTUAL SITE MODEL AND CLOSURE REQUEST

CHEVRON SERVICE STATION 94800
1700 CASTRO STREET
OAKLAND, CALIFORNIA
ACEH FUEL LEAK CASE NO. RO0342

Kiersten Hoey

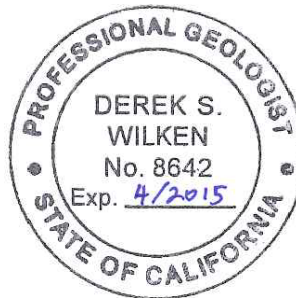

Derek Wilken PG 8642

Prepared by:
Conestoga-Rovers
& Associates

5900 Hollis Street, Suite A
Emeryville, California
U.S.A. 94608

Office: (510) 420-0700
Fax: (510) 420-9170

web:
<http://www.CRAworld.com>

APRIL 11, 2014

REF. NO. 060061 (12)

This report is printed on recycled paper

TABLE OF CONTENTS

	<u>Page</u>
1.0 INTRODUCTION.....	1
2.0 SITE BACKGROUND.....	1
2.1 SITE DISCRPTION.....	1
2.2 PREVIOUS ENVIRONMENTAL WORK.....	1
2.3 SITE GEOLOGY.....	2
2.4 SITE HYDROGEOLOGY.....	2
3.0 CONCEPTUAL SITE MODEL.....	3
3.1 HYDROCARBON SOURCE.....	3
3.2 HYDROCARBON SOURCE REMEDIATION.....	3
3.3 HYDROCARBON DISTRIBUTION.....	4
3.3.1 LNAPL.....	4
3.3.2 SOIL.....	4
3.3.3 GROUNDWATER.....	5
3.3.4 SOIL VAPOR.....	7
3.4 SENSITIVE RECEPTORS AND EXPOSURE PATHWAYS.....	8
3.4.1 SENSITIVE RECEPTOR SURVEY.....	8
3.4.2 PREFERENTIAL PATHWAYS.....	9
3.4.3 MEDIA-SPECIFIC EXPOSURE PATHWAYS.....	9
4.0 COMPARISON OF SITE CONDITIONS TO POLICY CRITERIA AND REQUEST FOR LOW THREAT CLOSURE.....	9
4.1 GENERAL CRITERIA.....	10
4.1.2 THE UNAUTHORIZED RELEASE IS LOCATED WITHIN THE SERVICE AREA OF A PUBLIC WATER SYSTEM.....	10
4.1.3 THE UNAUTHORIZED RELEASE CONSISTS ONLY OF PETROLEUM.....	10
4.1.4 THE UNAUTHORIZED ('PRIMARY') RELEASE FROM THE UST SYSTEM HAS STOPPED.....	10
4.1.5 FREE PRODUCT HAS BEEN REMOVED TO THE MAXIMUM EXTENT PRACTICABLE.....	10
4.1.6 A CONCEPTUAL SITE MODEL THAT ASSESSES THE NATURE, EXTENT, AND MOBILITY OF THE RELEASE HAS BEEN DEVELOPED.....	10
4.1.7 SECONDARY SOURCE HAS BEEN REMOVED TO THE EXTENT PRACTICABLE.....	11
4.1.8 SOIL AND GROUNDWATER HAVE BEEN TESTED FOR MTBE AND RESULTS REPORTED IN ACCORDANCE WITH HEALTH AND SAFETY CODE SECTION 25296.15.....	11
4.1.9 NUISANCE AS DEFINED BY WATER CODE SECTION 13050 DOES NOT EXIST AT THE SITE.....	11
4.2 MEDIA-SPECIFIC CRITERIA.....	11
4.2.1 GROUNDWATER.....	11
4.2.2 VAPOR INTRUSION TO INDOOR AIR.....	12
4.2.3 DIRECT CONTACT AND OUTDOOR AIR EXPOSURE.....	13
5.0 DATA GAPS.....	14
6.0 CONCLUSIONS AND RECOMMENDATIONS.....	14

LIST OF FIGURES
(Following Text)

FIGURE 1	VICINITY MAP
FIGURE 2	SITE PLAN
FIGURE 3	AREA MAP
FIGURE 4	GEOLOGIC CROSS SECTION A-A'
FIGURE 5	GEOLOGIC CROSS SECTION B-B'
FIGURE 6	TPHG CONCENTRATIONS IN SOIL (0-10 FBG)
FIGURE 7	BENZENE CONCENTRATIONS IN SOIL (0-10 FBG)
FIGURE 8	MTBE CONCENTRATIONS IN SOIL (0-10 FBG)
FIGURE 9	DISSOLVED HYDROCARBON CONCENTRATION MAP JUNE 3, 2013
FIGURE 10	WATER SUPPLY WELL LOCATIONS

LIST OF TABLES
(Following Text)

TABLE 1	SOIL ANALYTICAL DATA
TABLE 2	WELL CONSTRUCTION SPECIFICATIONS
TABLE 3	WATER SUPPLY WELL SURVEY
TABLE 4	SENSITIVE RECEPTOR SURVEY

LIST OF APPENDICES

APPENDIX A REGULATORY EMAIL

APPENDIX B BORING LOGS

APPENDIX C GROUNDWATER MONITORING AND SAMPLING DATA

APPENDIX D TREND GRAPHS AND DEGRADATION CALCULATIONS

APPENDIX E SWRCB LOW-THREAT UNDERGROUND STORAGE TANK CASE CLOSURE
POLICY EVALUATION

1.0 INTRODUCTION

Conestoga-Rovers & Associates (CRA) is submitting this *Conceptual Site Model and Closure Request (CSM)* on behalf of Chevron Environmental Management Company (EMC) for Chevron Service Station No. 94800 located at 1700 Castro Street in Oakland, California (Figure 1). In an August 15, 2013 email (Appendix A), Alameda County Environmental Health (ACEH) requested a CSM that identifies site data gaps, evaluates potential conduits, and evaluates the site with respect to the *Low-Threat Underground Storage Tank Case Closure Policy (LTCP)*. The LTCP was established in 2012 by the State Water Board to provide standard statewide closure criteria for low threat UST sites that are subject to Chapter 6.7 of Division 20 of the Health and Safety Code and Chapter 16 of Division 3 of Title 23 of the California Code of Regulations. A CSM, an evaluation of the LTCP case closure criteria, and conclusions and recommendations are presented herein.

2.0 SITE BACKGROUND

2.1 SITE DISCRIPTION

The site is currently an active Chevron Service Station located on Castro Street between 17th and 18th Streets in Oakland, California (Figure 1, 2, and 3) in a primarily commercial and residential area. Interstate 980 is located west of the site across Castro Street and runs below site grade. In 2004, the station was remodeled and currently contains a mini-mart, five dispensers under a common canopy in the center of the site, and one 15,000-gallon and one 20,000-gallon underground storage tank (USTs) located in the southern corner of the site.

2.2 PREVIOUS ENVIRONMENTAL WORK

In February 1997, Gettler-Ryan, Inc. (G-R) collected soil samples CT-1 through CT-5 from beneath the former dispenser islands during dispenser island upgrades. Based on the data from the initial sampling, G-R hand augured soil borings CB-1 through CB-12 to a maximum depth of 10 fbg to evaluate the extent of hydrocarbons in soil beneath the site. Groundwater was not encountered during boring advancement. Between 1997 and 2001, monitoring wells MW-1 through MW-7 were installed. In 2004, soil borings B1 through B4 were advanced to 16 fbg in the location of the proposed new UST pit to determine if the excavated soil could be reused onsite or needed to be disposed of at an offsite waste facility. Soil samples were collected from each boring at 4, 8, 12, and 16 fbg

and composited into four samples (Comp-1, Comp-2, Comp-3, and Comp-4) and submitted for analysis. No hydrocarbons were detected in the samples.

Additional information regarding the above investigations are available in the following reports.

- G-R's May 1, 1997 Dispenser Island Sampling and Hand-Augered Borings at Chevron Service Station #9-4800
- G-R's Well Installation Report, dated July 31, 1997
- G-R's May 25, 1999 Monitoring Well Installation Report.
- Delta Environmental Consultants' May 29, 2001 Monitoring Well Installation Report
- Cambria Environmental Management Technology's March 17, 2004 Soil Profiling Investigation

2.3 SITE GEOLOGY

The site is located on the western margin of the East Bay Plain, approximately ¼-mile north of the Oakland Inner Harbor, and 2.5 miles east of the San Francisco Bay (Figure 1). The site is a relatively flat, asphalt and concrete covered lot at an elevation of approximately 30 feet above mean sea level. As mapped by Helley and others (1979), soil in the vicinity consists of Pleistocene beach and dune deposits (Merritt sand) consisting of loose, well sorted fine to medium sand. Based on available geologic boring logs, soil encountered beneath the site consists primarily of sandy silt and sandy clay to approximately 15 fbg and sand to approximately 29 fbg. Clay was encountered at the bottom of all monitoring wells at approximately 30 fbg. Boring logs are included as Appendix B and geologic cross sections are included as Figures 4 and 5.

2.4 SITE HYDROGEOLOGY

The site is located in the East Bay Plain Sub-Basin of the Santa Clara Valley Groundwater Basin. The East Bay Plain Sub-basin aquifer system consists of unconsolidated sediments of Quaternary age. Deposits include the early Pleistocene Santa Clara Formation, the late Pleistocene Alameda Formation, the early Holocene Temescal Formation, and Artificial Fill. The nearest surface water is Lake Merritt located approximately 2,500 feet east of the site. Depth to water in the shallow groundwater aquifer in onsite wells varies from approximately 23 to 26 fbg and in offsite

well, MW-7, varies from approximately 26 to 28 fbg. A clay aquitard (Figures 4 and 5) appears to separate the shallow groundwater aquifer from deeper aquifers and likely inhibits vertical migration. Groundwater flows toward the west (rose diagram on Figure 2).

3.0 CONCEPTUAL SITE MODEL

3.1 HYDROCARBON SOURCE

The source of hydrocarbons in soil and groundwater are the former fuel USTs and associated product piping. Hydrocarbons were detected in compliance soil samples during the 1997 dispenser islands upgrades, and during the 2004 fuel USTs, dispensers, and product piping replacements.

3.2 HYDROCARBON SOURCE REMEDIATION

Primary Source Removal

On January 23, 1987, the 700-gallon heating oil UST was removed. In 1997, the dispenser islands were upgraded and in 2004 the four 10,000-gallon fuel USTs, dispenser islands, and product piping were removed and replaced during the station remodel. The upgrades are documented in G-R's May 1, 1997 *Dispenser Island Sampling and Hand-Augered Borings at Chevron Service Station #9-4800* and Cambria's October 20, 2004 *Underground Storage Tank Removal, Well Destruction, and Over-Excavation Report*.

Secondary Source Removal

During the 1997 upgrades, 36 cubic yards of soil and trench backfill were generated and disposed of at Chemical Waste Management, Inc. in Kettleman City, California. This is documented in G-R's May 1, 1997 *Dispenser Island Sampling and Hand-Augered Borings at Chevron Service Station #9-4800*.

On April 12, 2004, the west sidewall and floor of the former gasoline UST cavity were over-excavated to 20 fbg. Over-excavation was terminated when the groundwater capillary fringe was encountered. The total dimensions of the gasoline UST cavity excavation were approximately 20 feet long by 17 feet wide and 15 to 20 feet deep. At the bottom of the UST cavity near the capillary fringe, 1.5 feet of pea gravel and 200 pounds of Oxygen Release Compound (ORC) were spread over the UST cavity floor. On April 13, 2004, soil beneath the eastern dispenser island was over-excavated to remove the hydrocarbon-impacted soil in the vicinity of soil sample P-3. Additional

over-excavation occurred on April 15, 2004. The dimensions of the over-excavation were approximately 20 feet by 17 feet and 14 feet deep. A total of 12,180 tons of soil was excavated, stockpiled onsite, profiled, and transported by Integrated Waste Management of Milpitas, California, to Forward Landfill in Manteca, California. The over-excavations are detailed in Cambria's October 20, 2004 *Underground Storage Tank Removal, Well Destruction, and Over-Excavation Report*.

3.3 HYDROCARBON DISTRIBUTION

Primary constituents of concern (COCs) beneath the site are total petroleum hydrocarbons as gasoline (TPHg), benzene, and methyl tertiary butyl ether (MTBE). Other COCs are total petroleum hydrocarbons as diesel (TPHd), toluene, ethylbenzene, and xylenes.

3.3.1 LNAPL

No light non-aqueous liquid (LNAPL) has ever been detected.

3.3.2 SOIL

Residual TPHd is primarily located beneath the former fuel USTs between 14 and 20 fbg at a maximum concentration of 6,200 milligrams per kilogram (mg/kg). TPHd was also detected between 4 and 10 fbg near the former central dispenser island in CT-3 and CB-6 at a maximum concentration of 640 mg/kg. TPHg and benzene are primarily located in shallow soil beneath the former central and eastern dispenser islands between 4 and 10 fbg at maximum concentrations of 890 mg/kg and 15 mg/kg, respectively. MTBE is primarily located in deeper soil (>10 fbg) below the dispenser islands at a maximum concentration of 6.3 mg/kg. TPHg, benzene, and MTBE concentrations in shallow soil (<10 fbg) are illustrated on Figures 6, 7 and 8, respectively. Hydrocarbons in soil are limited to small pockets onsite and the extents are adequately defined by the 23 soil borings, 7 wells and 32 compliance soil samples collected beneath the former dispenser islands and USTs. Cumulative soil data is listed in Table 1.

In terms of the LTCP criteria, residual TPHg between 0 and 10 fbg with a concentration of 100 mg/kg or greater was reported at four onsite locations in the vicinity of the dispenser islands, product piping, and former fuel USTs. Only one sample (CT-3) collected beneath the product lines at 4 fbg contains a benzene concentration that

exceeds a LTCP criteria for direct contact or exposure to outdoor air. No ethylbenzene or naphthalene criteria were exceeded by concentrations in soil beneath the site. This is discussed further in Section 4.2.3.

3.3.3 GROUNDWATER

Groundwater has been monitored and sampled at the site for 16 years; historically by a total of 7 wells, but currently by 5 onsite and offsite wells. Wells MW-5 and MW-6 were destroyed during the 2004 station upgrades. Recent groundwater data are presented in Table A and historic groundwater data are presented in Appendix C. Monitoring well construction details are included in Table 2. Current extent of hydrocarbons in groundwater and hydrocarbon concentration trends and degradation rates are included below.

Distribution of Hydrocarbons in Groundwater

During the Fourth Quarter 2013 (December 12, 2013) active monitoring wells MW-1, MW-2, MW-3, MW-4, and MW-7 were sampled. Current groundwater analytical results for TPHd, TPHg, benzene, toluene, ethylbenzene, and xylenes (BTEX), and MTBE are summarized below in Table A.

TABLE A: GROUNDWATER ANALYTICAL DATA							
Well ID	TPHd (µg/L)	TPHg (µg/L)	Benzene (µg/L)	Toluene (µg/L)	Ethylbenzene (µg/L)	Total Xylenes (µg/L)	MTBE (µg/L)
Groundwater WQOs	100	100	1	40	30	20	5
MW-1	<50	<50	<0.5	<0.5	<0.5	<0.5	<0.5
MW-2	89 J	69 J	<0.5	<0.5	<0.5	<0.5	0.7 J
MW-3	140	110	1	<0.5	<0.5	2	74
MW-4	100	<50	<0.5	<0.5	<0.5	<0.5	12
MW-7	350	160	2	<0.5	<0.5	3	50
WQOs	Water Quality Objectives from Screening for Environmental Concerns at Sites with Contaminated Soil and Groundwater, Prepared by California Regional Water Quality Control Board San Francisco Bay Region, Interim Final - November 2007, (Revised May 2013), Table F-1a-Groundwater Screening Levels-Current or Potential Drinking Water Resource.						
µg/L	Micrograms per Liter						
J	Estimated Value (the result is ≥the Method Detection Limit and < the Limit of Quantitation)						

TPHd and TPHg are detected in most wells, but at concentrations near or below the Water Quality Objectives (WQOs). Benzene is also detected in onsite well MW-3 and offsite well MW-7 at or near the WQO. No toluene or ethylbenzene were detected and total xylenes are only detected in onsite well MW-3 and offsite well MW-7 at

concentrations below the WQO. MTBE is detected above the WQO in onsite wells MW-3 and MW-4 and offsite well MW-7 (Figure 9). The dissolved MTBE plume is defined crossgradient to the north and south by wells MW-1 and MW-2, and is defined to the east (upgradient) by well MW-3, but cannot be defined downgradient of well MW-7 due to the immediate proximity of Interstate 980.

Hydrocarbon Trends and Degradation Rates

CRA uses the guidance provided within the United States Environmental Protection Agency (EPA) document *Calculation and Use of First-Order Rate Constants for Monitored Natural Attenuation Studies* (November 2002) to estimate the time for groundwater concentrations to reach WQOs. CRA also uses the EPA document *On-line Tools for Assessing Petroleum Releases* (September 2004) to assess the proper methodology of determining where to begin a trend analysis. A receptor is located some distance from the source, and no impact to the receptor is seen when the release first occurs. The analytes take time to travel to the receptor. The first data points that show an analyte detection is called the first arrival time. The first arrival time varies for each receptor based upon distance from the receptor and the transport rates through the heterogeneous medium.

As the analyte plume expands and stabilizes, the analyte concentration reaches the maximum concentration. If the source of the release is finite (e.g., a single release from an underground storage tank), the concentration will eventually decrease from the maximum, to below the concentration of concern. This period is called the duration.

CRA evaluates groundwater monitoring data from each well (the receptor) and creates a degradation trend analysis for site COCs from the maximum detection through the latest sampling date. The starting point can vary from the maximum detection if the transport mechanisms are not sufficiently linear. For example, groundwater monitoring data may show that the maximum concentration occurred at some point in the past and that degradation seemed to be occurring. However, due to the heterogeneous nature of the subsurface and seasonal groundwater level fluctuations, the duration does not demonstrate a steady degradation behavior. The concentrations of the analyte may increase one or more times before showing consistent attenuation towards the concentration objective.

CRA estimated times for MTBE in wells MW-1, MW-2, MW-3, MW-4, and MW-7 and TPHd, TPHg, and benzene in well MW-3 to achieve WQOs¹. TPHd, TPHg, and benzene

1. WQO are the San Francisco Regional Water Quality Control Board's Environmental Screening Levels (ESLs)

were not calculated in any other well because they are very near or below the WQOs. CRA used the following first order exponential decay rate calculation:²

$$y = be^{(ax)}$$

Where "a" is a decay constant, "b" is a concentration at time (x), y is concentration (ESL), and "x" is time.

The results of these analyses are described below. A summary of historical maximum concentrations, the most current concentrations, and projections to meet the WQOs are presented in Table B. As shown on Table B, dissolved hydrocarbon concentrations are expected to reach and remain below WQOs in MW-3 within a maximum of 31 years. MTBE is expected to remain below the WQO of 5 micrograms per liter (µg/L) in onsite wells within 5 years and in offsite well MW-7 within 10 years. The trend graphs and degradation calculations are presented in Appendix D.

TABLE B: SUMMARY OF DEGRADATION RATE CALCULATIONS						
<i>Well</i>	<i>Analyte</i>	<i>Maximum Concentration (µg/L)</i>	<i>Current (Most Recent) Concentration (µg/L)</i>	<i>WQO</i>	<i>Year to Remain Below WQO</i>	<i>Time to Remain Below WQO (years)</i>
MW-1	MTBE	590	1	5	2013	<1
MW-2	MTBE	13,000	0.7 J	5	2013	<1
MW-3	TPHd	310	140	100	2012	<1
	TPHg	8,650	110	100	2013	<1
	Benzene	1,040	1	1	2017	3
	MTBE	3,300	74	5	2019	5
MW-4	MTBE	7,840	12	5	2015	1
MW-7	MTBE	41,000	50	5	2024	10
<u>Notes</u>						
<1 = Current concentrations are in the same order of magnitude as the WQO, and have been for several sampling events.						

3.3.4 SOIL VAPOR

Soil vapor samples have not been collected at the site. This site is an active commercial service station and will likely be so for the foreseeable future. The LTCP states that

² EPA-Groundwater Issue; Calculation and Use of First-Order Rate Constants for Monitored Natural Attenuation Studies; Charles J. Newell, et al., 2002.

satisfaction of the media-specific criteria for petroleum vapor intrusion to indoor air is not required at active commercial petroleum fueling facilities, except in cases where release characteristics can be reasonably believed to pose an unacceptable health risk. Concentrations detected in soil and groundwater do not appear to pose an unacceptable health risk.

3.4 SENSITIVE RECEPTORS AND EXPOSURE PATHWAYS

3.4.1 SENSITIVE RECEPTOR SURVEY

The site is an active service station in a primarily commercial and residential area with residences located on the north, east, and south sides of the site and Highway 980 located across Castro Street to the west. Potential sensitive receptors are discussed below and listed in Tables 3 and 4.

The property is provided water by the East Bay Municipal Utility District. According to GeoTracker's Groundwater Ambient Monitoring and Assessment (GAMA) database, the nearest water supply well is over 1 mile southwest (crossgradient) of the site. CRA also contacted the California Department of Water Resources (DWR) and Alameda County Public Works Agency (ACPWA) for well completion reports within 2,000 feet of the site. Records indicated no water supply wells are located within 2,000 feet of the site. The nearest well is an irrigation well located approximately 2,200 feet south (crossgradient) of the site. Water supply wells are listed on Table 3 and located on Figure 10. Based on the direction and distance of these wells from the site, there is no threat of hydrocarbons originating at the site affecting these wells.

CRA also reviewed online mapping services to identify other potential receptors within a ¼-mile (1,320 feet) radius, including schools, hospitals, daycare centres, and eldercare facilities. Two schools, two day care centres, and one elder care were identified in the search area. No hospitals are located near the site. The nearest sensitive receptor is, The San Pablo Residential Community located 550 feet northeast (upgradient). Based on the upgradient direction of the elder care and the low dissolved hydrocarbon concentrations detected in upgradient well MW-3, there is no threat of hydrocarbons originating at the site affecting the elder care facility. The nearest downgradient sensitive receptor is Lafayette Elementary School located 1,000 feet to the west and as the school is on the opposite side of Highway 980 the dissolved hydrocarbons do not pose a threat to the school.

The nearest surface water bodies are Lake Merritt located 2,500 east (upgradient) and Oakland Inner Harbor approximately 4,000 feet south (crossgradient) of the site. Based on the direction and distance of the lake and harbor, there is no threat of hydrocarbons originating at the site affecting these water bodies. Sensitive receptors and surface waters are listed on Table 4.

3.4.2 PREFERENTIAL PATHWAYS

Potential underground utilities include electric, communication, natural gas, storm drains, and sanitary sewers. Depth to groundwater in onsite wells varies from approximately 23 to 26 fbg and in offsite well, MW-7, varies from approximately 26 to 28 fbg which is well below typical underground utility depths ranging from 2 to 10 fbg. Therefore, it is highly unlikely any preferential pathway for hydrocarbon migration exists near the site.

Interstate 980 is approximately 20 feet lower than offsite well MW-7.³ Based on the measured groundwater depths in MW-7, groundwater is likely below the grade of Interstate 980. Therefore, it is unlikely any preferential pathway for hydrocarbon migration exists beneath the freeway.

3.4.3 MEDIA-SPECIFIC EXPOSURE PATHWAYS

The LTCP contains criteria that are defined as low threat to groundwater resources and human health for each of the three media-specific exposure pathways: groundwater, vapor intrusion to indoor air, and direct contact and outdoor air exposure from impacted soil. These pathways are addressed in Section 4.0.

4.0 COMPARISON OF SITE CONDITIONS TO POLICY CRITERIA AND REQUEST FOR LOW THREAT CLOSURE

Based on the information presented herein, the site appears to adequately meet the general criteria and media-specific criteria (as applicable) presented in the LTCP. An additional itemized evaluation documenting site conditions with respect to general and media-specific criteria for low-threat UST case closure is included as Appendix E.

3. Google Earth elevation measurement difference between MW-7 and Interstate 980

4.1 GENERAL CRITERIA

4.1.2 THE UNAUTHORIZED RELEASE IS LOCATED WITHIN THE SERVICE AREA OF A PUBLIC WATER SYSTEM

Yes. The site is located in the City of Oakland, and Oakland obtains its water supply from East Bay Municipal Utility District (EBMUD), of which 90 percent is sourced from reservoirs in the Sierra Nevada, and the remaining water supply is sourced from protected local watersheds.⁴

4.1.3 THE UNAUTHORIZED RELEASE CONSISTS ONLY OF PETROLEUM

Yes. All unauthorized releases consisted of hydrocarbons generated from either the gasoline or diesel USTs, or product piping.

4.1.4 THE UNAUTHORIZED ('PRIMARY') RELEASE FROM THE UST SYSTEM HAS STOPPED

Yes. On January 23, 1987, the 700-gallon heating oil UST was removed. In 1997, the dispenser islands were upgraded and in 2004 the four 10,000-gallon fuel USTs, dispenser islands, and product piping were removed and replaced during the station remodel.

4.1.5 FREE PRODUCT HAS BEEN REMOVED TO THE MAXIMUM EXTENT PRACTICABLE

Yes. No LNAPL has ever been detected beneath the site.

4.1.6 A CONCEPTUAL SITE MODEL THAT ASSESSES THE NATURE, EXTENT, AND MOBILITY OF THE RELEASE HAS BEEN DEVELOPED

Yes. A conceptual site model is presented herein.

⁴ Water supply information for the City of Oakland is from EBMUD's 2011 *Annual Water Quality Report*.

**4.1.7 SECONDARY SOURCE HAS BEEN REMOVED
TO THE EXTENT PRACTICABLE**

Yes. During the 1997 upgrades, 36 cubic yards of soil and trench backfill were generated and disposed of at Chemical Waste Management, Inc. in Kettleman City, California. In April 2004, a total of 12,180 tons of soil was over-excavated from the former fuel UST pit and in the area of former eastern dispenser island and product piping.

**4.1.8 SOIL AND GROUNDWATER HAVE BEEN TESTED FOR MTBE
AND RESULTS REPORTED IN ACCORDANCE WITH HEALTH
AND SAFETY CODE SECTION 25296.15**

Yes. Soil and groundwater have been tested for MTBE and are presented in Table 1 (soil data) and Appendix C (groundwater data).

**4.1.9 NUISANCE AS DEFINED BY WATER CODE
SECTION 13050 DOES NOT EXIST AT THE SITE**

Nuisance is defined as follows per Water Code Section 130580. All three of the following requirements must be met to cause nuisance:

- Injurious to health, offensive to senses, or an obstruction of free property use
- Affects at the same time an entire community or neighborhood
- Occurs during or as the result of treatment or disposal of wastes (i.e., petroleum release)

Nuisance does not exist at the site. No community nuisance complaints have been filed to date.

4.2 MEDIA-SPECIFIC CRITERIA

4.2.1 GROUNDWATER

Long-term groundwater monitoring data show that the plume above WQOs is stable or decreasing in areal extent, as required by the LTCP. The Policy has five classes that define a stable plume as "low threat". Because the length of the hydrocarbon plume that exceeds water quality objectives is unknown (the plume cannot realistically or effectively be defined downgradient of well MW-7), the site does not meet the Policy

criteria for Plume Classes 1 through 4. However, it does meet Class 5: Based on an analysis of site specific conditions that under current and reasonably anticipated near-term future scenarios, the contaminant plume poses a low threat to human health and safety and to the environment and water quality objectives will be achieved within a reasonable time frame.

- a) This is an active gasoline station with only 2 µg/L benzene detected in groundwater.
- b) No LNAPL has ever been detected beneath the site.
- c) The nearest surface waters (Lake Merritt and Oakland Inner Harbor) are located over 2,000 feet upgradient and crossgradient of the dissolved contaminant plume and therefore will not be affected by hydrocarbons originating at the site.
- d) The nearest existing water supply well or surface water body is greater than 250 feet from the defined plume boundary. The nearest water supply wells are irrigation wells located over 2,000 feet south of the site and the nearest surface water body is Lake Merritt approximately 2,500 feet east of the site. The dissolved plume boundaries are defined to the south by MW-1 and to the east by MW-3.
- e) The nearest sensitive receptor is an elder care facility located 550 feet east of the site; however due to its upgradient location outside of the hydrocarbon plume and the low hydrocarbon concentrations detected in upgradient well MW-3, it is highly unlikely hydrocarbons originating at the site will affect the elder care facility. The nearest downgradient receptor is Lafayette Elementary School located 1,000 feet downgradient of the site on the opposite side of the highway. Because of the low BTEX concentrations in groundwater, it is unlikely hydrocarbons originating at the site will affect the elementary school.

Therefore, site conditions meet LTCP criteria for groundwater.

4.2.2 VAPOR INTRUSION TO INDOOR AIR

This is an active service station. According to the LTCP, active service stations are exempt from satisfying the vapor intrusion criteria. The policy states, "Exposures to petroleum vapors associated with historical fuel system releases are comparatively insignificant relative to exposures from small surface spills and fugitive vapor releases that typically occur and active fueling facilities. Therefore, satisfaction of the media-specific criteria for petroleum vapor intrusion to indoor air is not required at active commercial petroleum fueling facilities, except in cases where release characteristics can be reasonably believed to pose an unacceptable health risk." The low

hydrocarbon concentrations detected in soil and groundwater beneath the site do not appear to pose an unacceptable health risk.

4.2.3 DIRECT CONTACT AND OUTDOOR AIR EXPOSURE

The Policy contains concentration criteria for benzene, ethylbenzene, naphthalene, and PAHs in soil between 0 and 5 fbg and 5 to 10 fbg that are defined as “low threat” for the direct contact and outdoor air pathway for various receptors. The Policy criteria and maximum concentrations for the depth ranges are listed below in Table C:

TABLE C: POLICY CRITERIA AND MAXIMUM SITE SOIL CONCENTRATIONS 0-10 FBG FOR DIRECT CONTACT/OUTDOOR AIR EXPOSURE						
<i>Location ID</i>	<i>Date</i>	<i>Depth (fbg)</i>	<i>Benzene</i>	<i>Ethylbenzene</i>	<i>Naphthalene</i>	<i>PAHs</i>
<i>Residential</i>	0 to 5 fbg		1.9	21	9.7	0.063
	<i>Volatilization to outdoor air 5 to 10 fbg</i>		2.8	32	9.7	NA
<i>Commercial /Industrial*</i>	0 to 5 fbg		8.2	89	45	0.68
	<i>Volatilization to outdoor air 5 to 10 fbg</i>		12	134	45	NA
<i>Utility Worker*</i>	0 to 10 fbg		14	314	219	4.5
CT-3	2/18/97	4	15	17	NA	NA
CB-2	2/22/97	6	3	13	NA	NA
P-1	4/8/04	6	<0.1	<0.1	<0.1	NA
All concentrations displayed in milligrams per kilogram (mg/kg) * = Concentrations of Petroleum Constituents in Soil That Will Have No Significant Risk of Adversely Affecting Human Health – California State Water Resources Control Board <i>Low-Threat Underground Storage Tank Case Closure Policy</i> , Section 3: Direct Contact and Outdoor Air Exposure (August 2012) fbg = Feet Below Grade NA = Not Analyzed PAHs = Poly-aromatic hydrocarbons as benzo(a)pyrene toxicity equivalent ** = No concentrations at or exceeding the BaP equivalent for 16 priority pollutant PAHs (Naphthalene; Acenaphthene; Acenaphthylene; Anthracene; Benzo(a)anthracene; Benzo(a)pyrene; Benzo(b)fluoranthene; Benzo(g,h,i)perylene; Benzo(k)fluoranthene; Chrysene; Dibenz(a,h)anthracene; Fluoranthene; Fluorene; Indeno(1,2,3-cd)pyrene; Phenanthrene; Pyrene)						

This is an active gasoline station; therefore, the residential values do not apply to this site. Of the 19 soil samples collected between 0 and 5 fbg, 25 soil samples collected between 5 and 10 fbg, and 44 soil samples collected between 0 and 10 fbg, only sample CT-3 collected beneath the product lines at 4 fbg contains a benzene concentration above the commercial worker direct contact value. This sample was collected over 16 years

ago. No benzene was detected in the 6 fbg soil sample P-5 collected immediately adjacent to sample CT-3. This suggests that the benzene detected in CT-3 has attenuated and the results for sample P-5 are more representative of current conditions.

Soil was not analyzed for poly-aromatic hydrocarbons (PAHs) because soil has not been affected by waste oil or Bunker C fuel. Cumulative soil data is listed in Table 1.

5.0 DATA GAPS

Based on the review of the site conditions, CRA has identified that the downgradient delineation of MTBE is a data gap. However, due to the presence of the Interstate 980 downgradient of MW-7, additional assessment of the MTBE plume down-gradient is not feasible. Based on the observed concentration degradation trends for MW-7 and the distance to downgradient sensitive receptors, it is unlikely that receptors will be affected by the plume.

6.0 CONCLUSIONS AND RECOMMENDATIONS

Based on our review, the site conditions meet the general and media-specific criteria established in the LTCP, and therefore poses a low threat to human health, safety, and the environment, and satisfy the case-closure requirements of the Health and Safety Code section 25296.10, and case closure is consistent with Resolution 92-49 that requires that cleanup goals be met within a reasonable time frame.

Because there is no high concentration dissolved plume that merits additional monitoring, CRA recommends that groundwater monitoring be suspended until ACEH reviews this closure request.

FIGURES

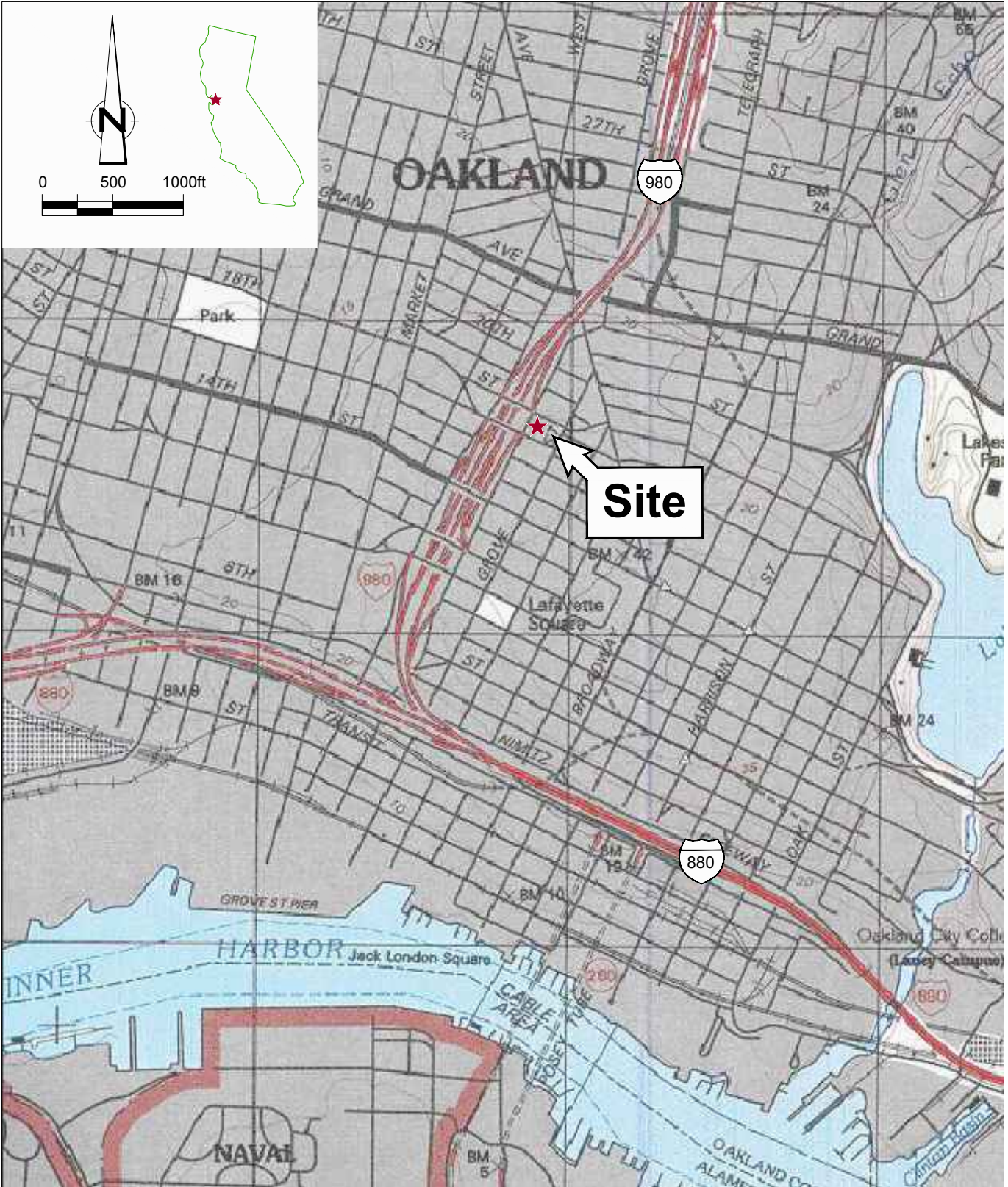
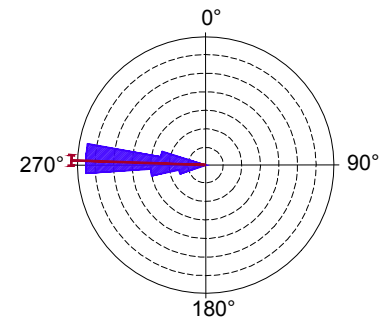
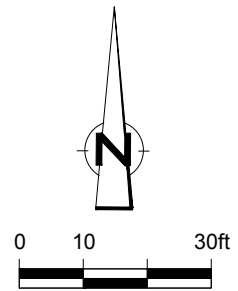
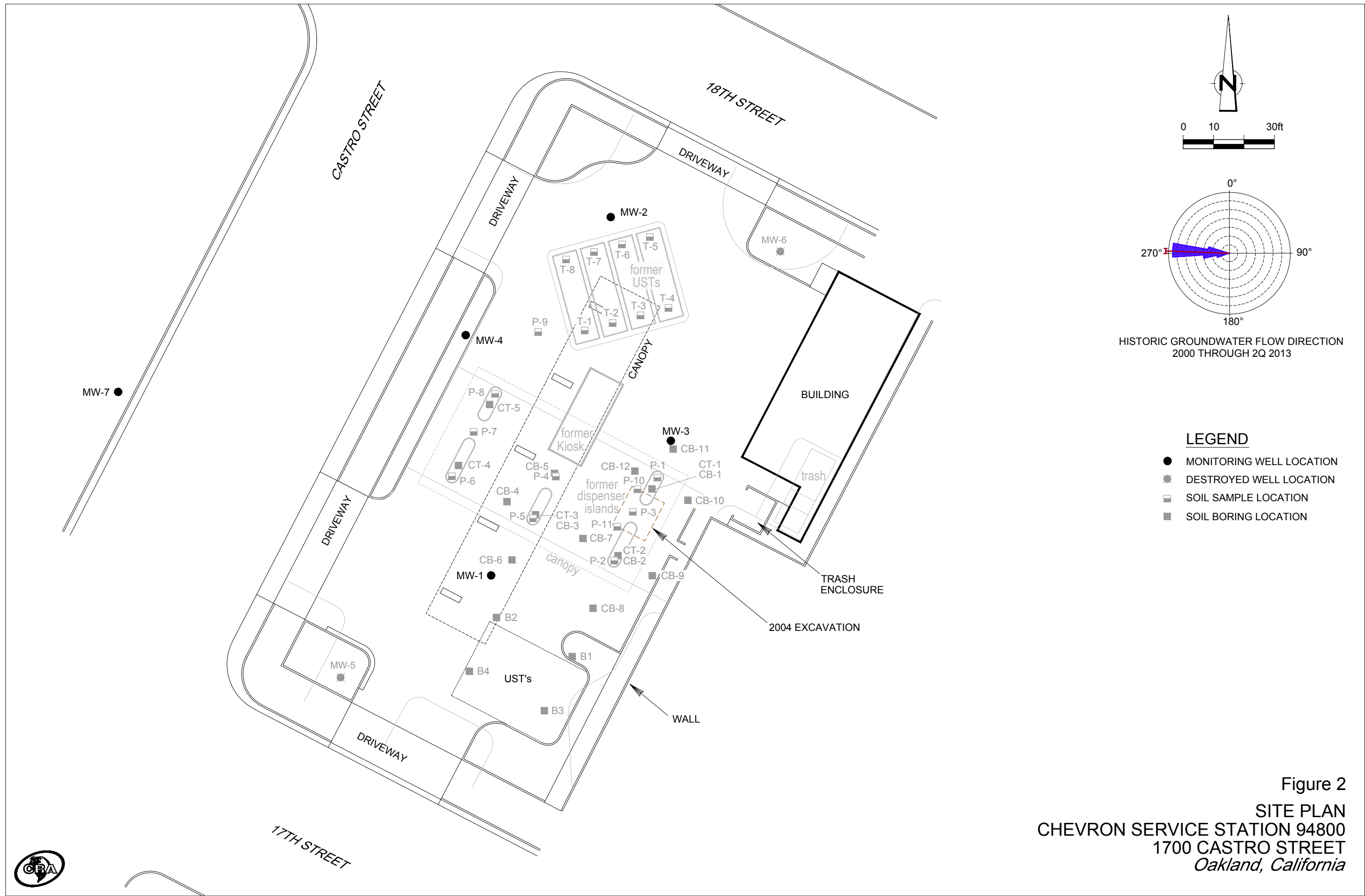

Figure 1
 VICINITY MAP
 CHEVRON SERVICE STATION 94800
 1700 CASTRO STREET
 Oakland, California





HISTORIC GROUNDWATER FLOW DIRECTION
2000 THROUGH 2Q 2013

LEGEND

- MONITORING WELL LOCATION
- ⦿ DESTROYED WELL LOCATION
- SOIL SAMPLE LOCATION
- SOIL BORING LOCATION

Figure 2
SITE PLAN
CHEVRON SERVICE STATION 94800
1700 CASTRO STREET
Oakland, California



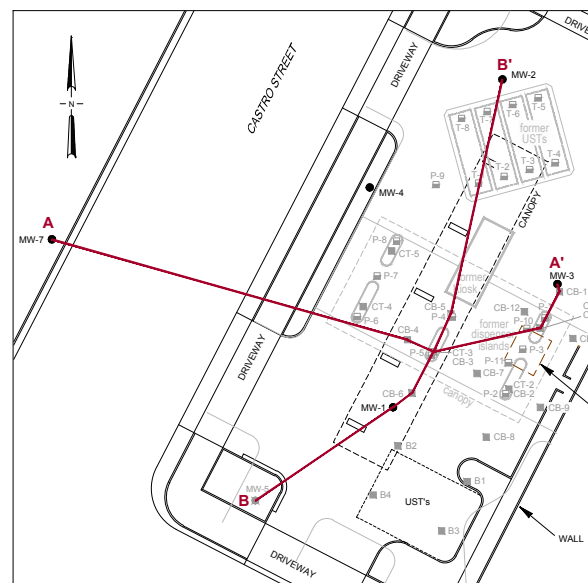
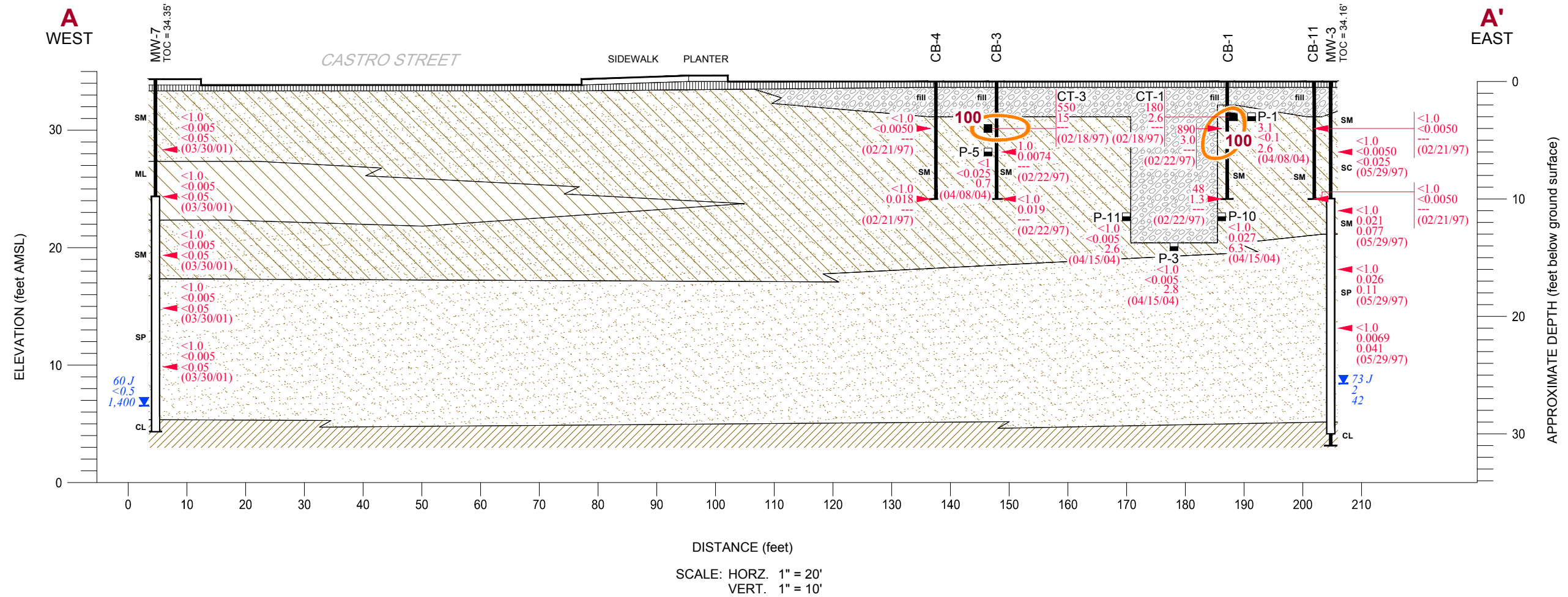

EXPLANATION

- cl - Clay
- ml - Clayey Silt
- sc - Clayey Sand
- sm - Silty Sand
- sp - Poorly Graded Sand
- sw - Well Graded Sand
- = Fill (Tank Pit)
- = Asphalt
- Sample location
- Sample location
- Sample location
- Groundwater elevation

Well ID — Well Designation
Elev. — Top of Casing Elevation
(offset)

- Groundwater Monitoring Well
- Well Screen Interval
- Bottom of boring

TPH_g
TPH_d
Benzene
MTBE

Hydrocarbon concentrations in Groundwater, in parts per billion

TPH_g
TPH_d
Benzene
MTBE

Hydrocarbon concentrations in Soil, in parts per million

100 TPH_g concentration contour line in parts per million

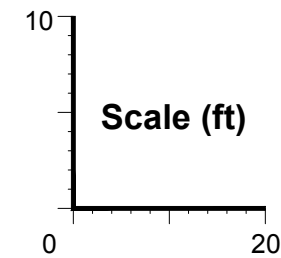
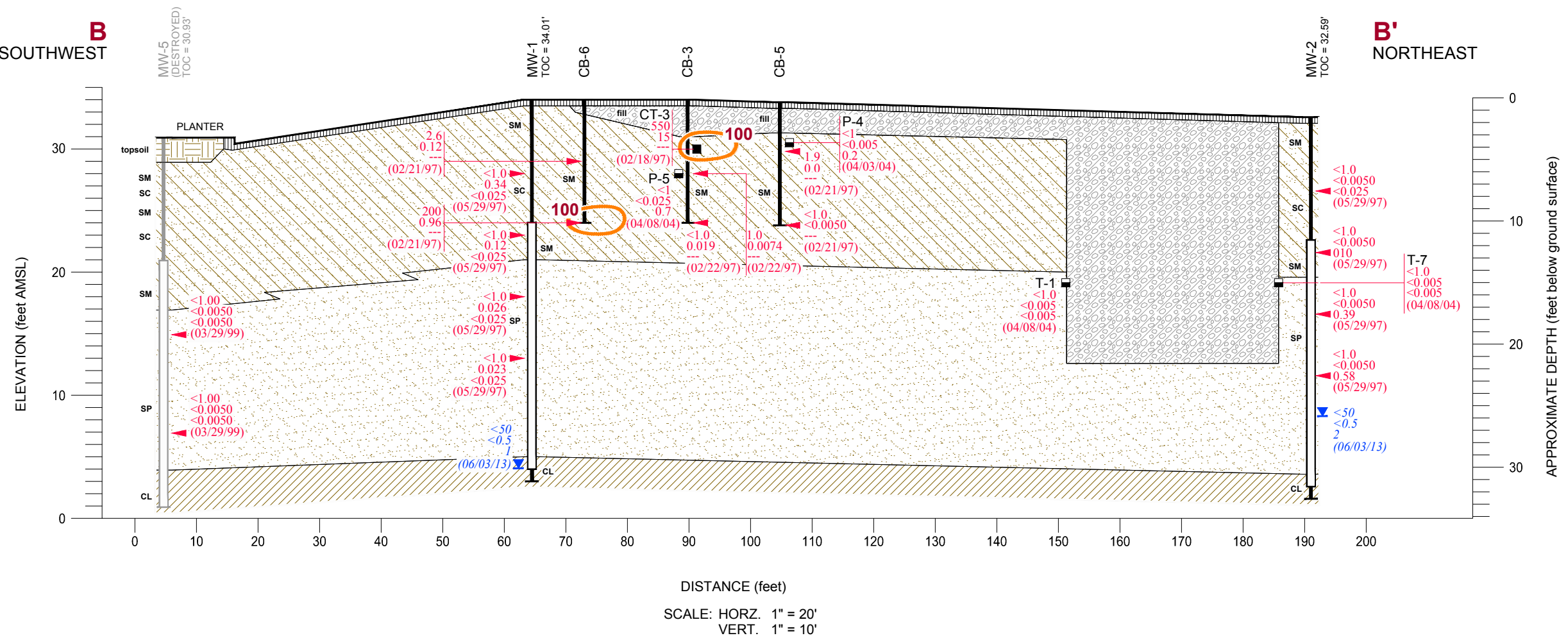

Figure 4
GEOLOGIC CROSS SECTION A-A'
CHEVRON SERVICE STATION 94800
1700 CASTRO STREET
Oakland, California



B
SOUTHWEST

B'
NORTHEAST



SCALE: HORZ. 1" = 20'
VERT. 1" = 10'

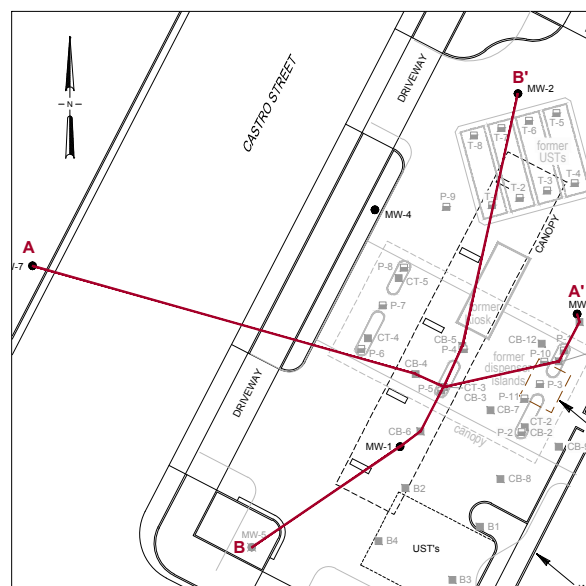

EXPLANATION

- CL - Clay
- ML - Clayey Silt
- SC - Clayey Sand
- SM - Silty Sand
- SP - Poorly Graded Sand
- SW - Well Graded Sand
- = Fill (Tank Pit)
- = Asphalt
- Sample location
- Sample location
- Sample location
- Groundwater elevation

Well ID — Well Designation
Elev. (offset) — Top of Casing Elevation

- Groundwater Monitoring Well
- Well Screen Interval
- Bottom of boring

TPHg
TPHd
Benzene
MTBE

Hydrocarbon concentrations in Groundwater, in parts per billion

TPHg
TPHd
Benzene
MTBE

Hydrocarbon concentrations in Soil, in parts per million

100 — TPHg concentration contour line in parts per million

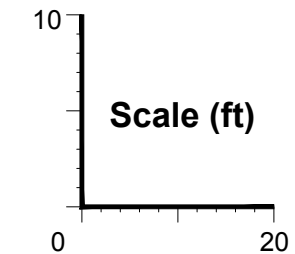
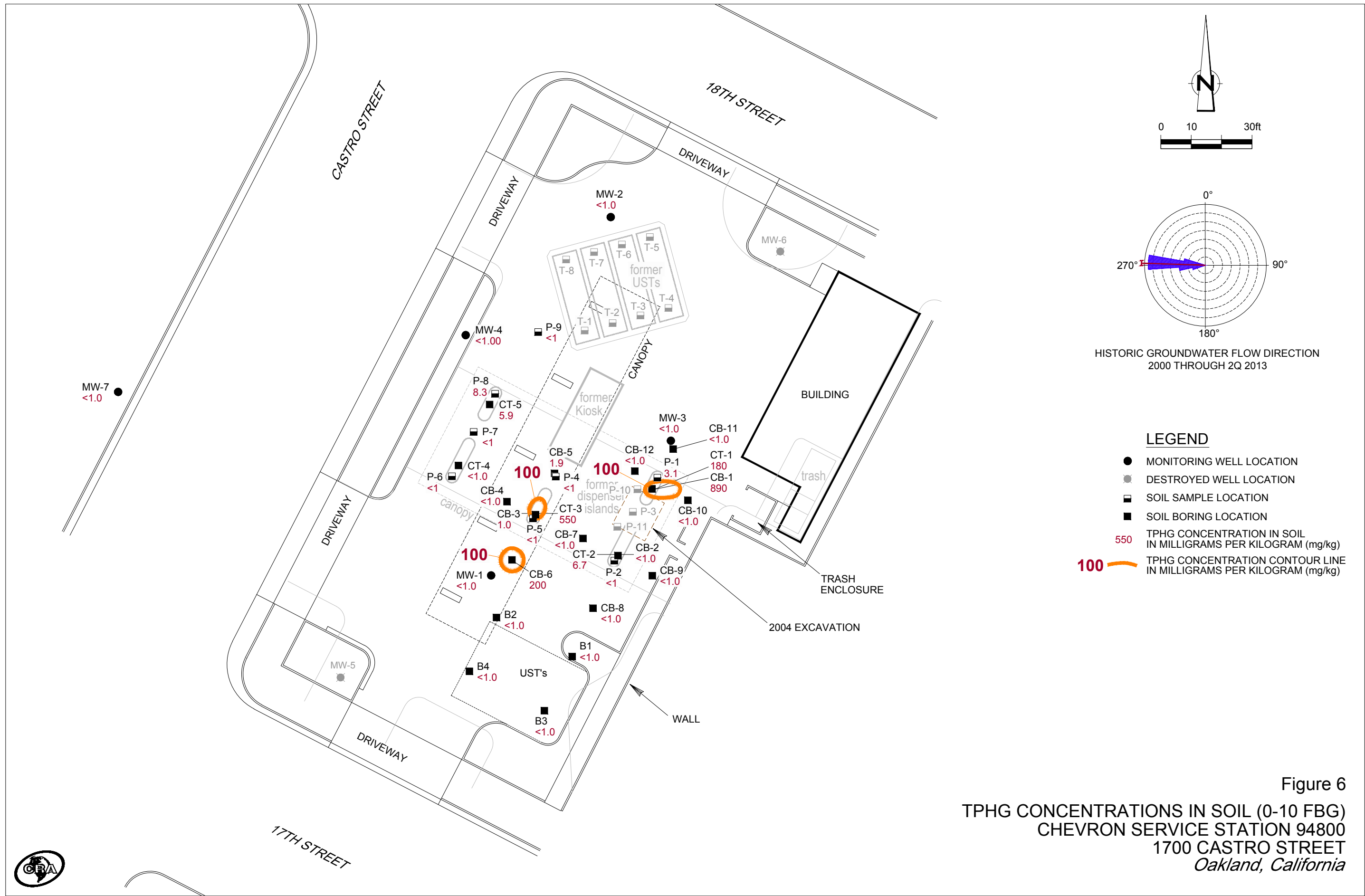

Figure 5
GEOLOGIC CROSS SECTION B-B'
CHEVRON SERVICE STATION 94800
1700 CASTRO STREET
Oakland, California





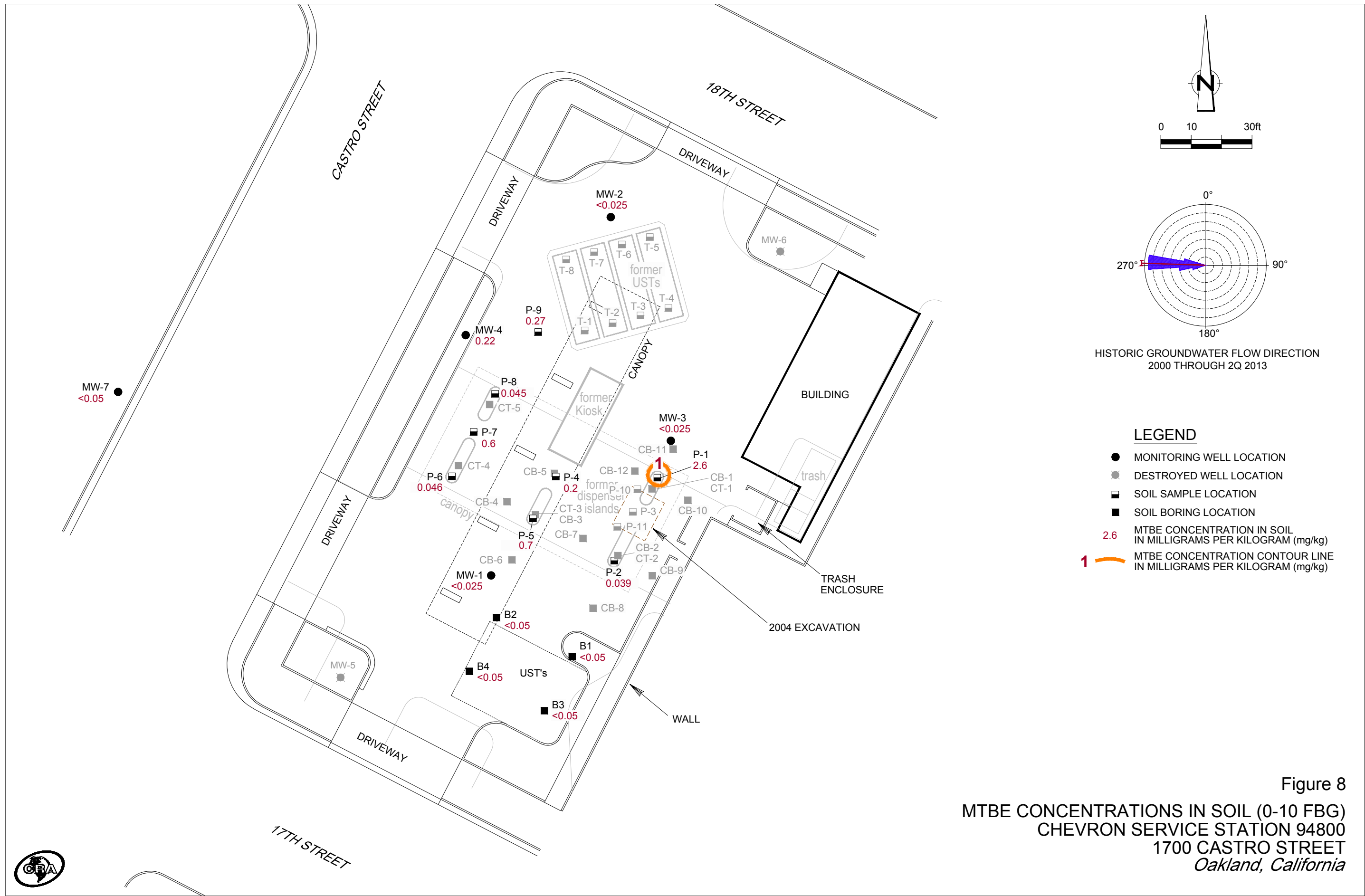
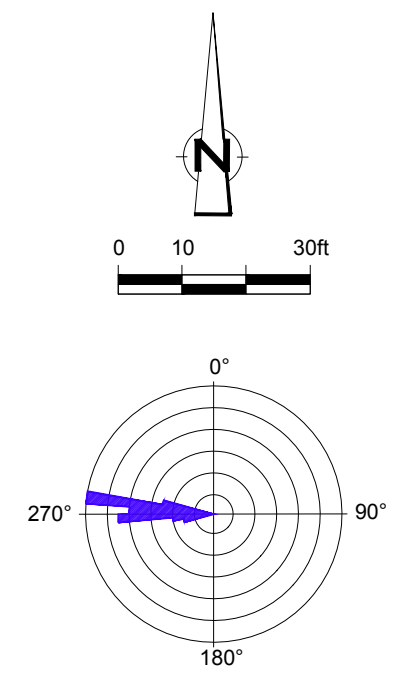
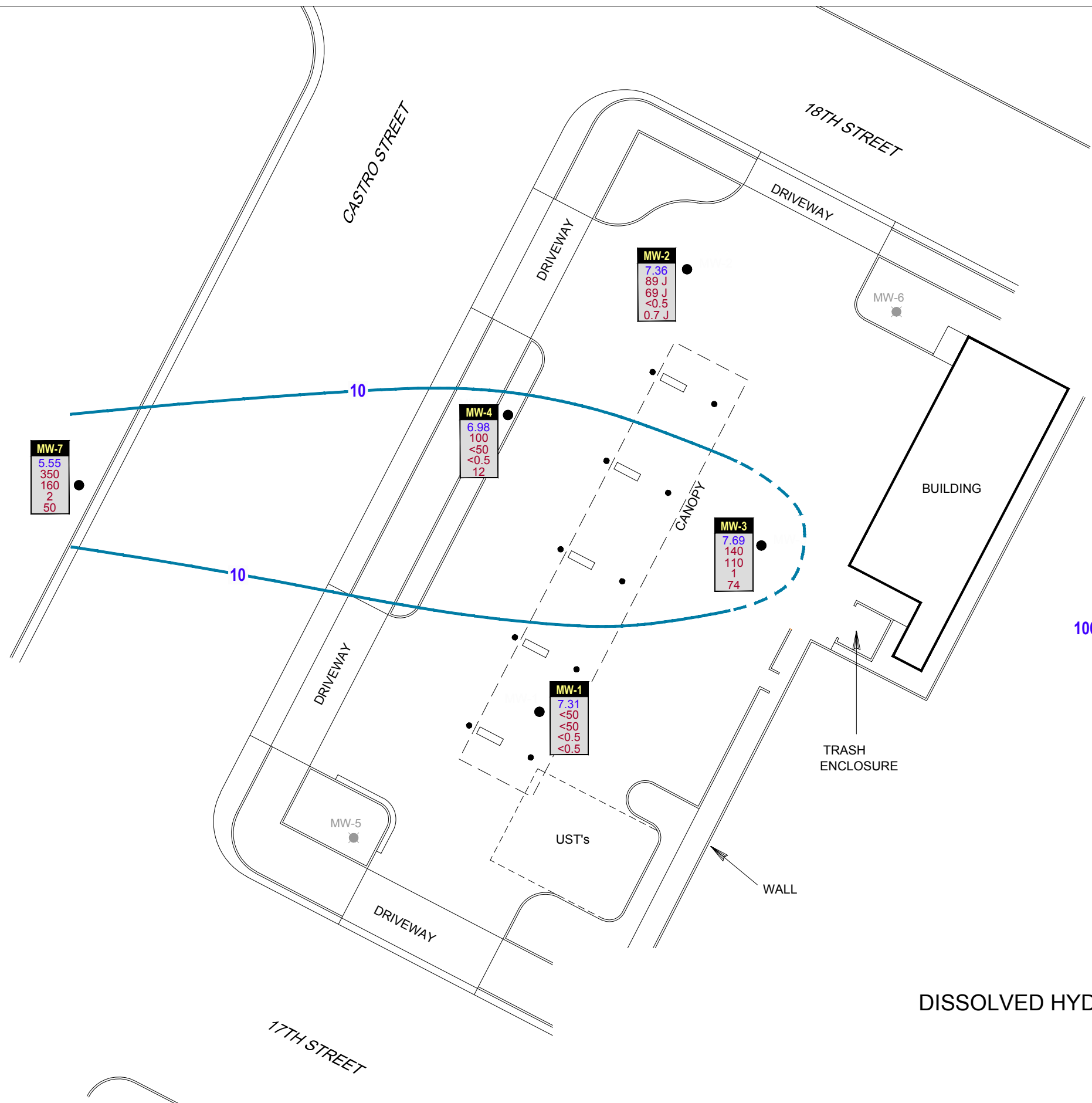

Figure 8
 MTBE CONCENTRATIONS IN SOIL (0-10 FBG)
 CHEVRON SERVICE STATION 94800
 1700 CASTRO STREET
 Oakland, California





HISTORIC GROUNDWATER FLOW DIRECTION
2000 THROUGH 4Q 2012

LEGEND

- MONITORING WELL LOCATION
- MW-5 ● DESTROYED WELL LOCATION
- 100 ——— MTBE CONCENTRATION CONTOUR, IN MICROGRAMS PER LITER (µg/L), DASHED WHERE INFERRED
- | |
|------|
| WELL |
| ELEV |
| TPHd |
| TPHg |
| BENZ |
| MTBE |

 WELL DESIGNATION
- GROUNDWATER ELEVATION (MSL)
- TPHd CONCENTRATION (µg/L)
- TPHg CONCENTRATION (µg/L)
- BENZENE CONCENTRATION (µg/L)
- MTBE CONCENTRATION (µg/L)
- J ESTIMATED VALUE BETWEEN METHOD DETECTION LIMIT AND LABORATORY REPORTING LIMIT

Figure 9
DISSOLVED HYDROCARBON CONCENTRATION MAP
CHEVRON SERVICE STATION 94800
1700 CASTRO STREET
Oakland, California
December 12, 2013



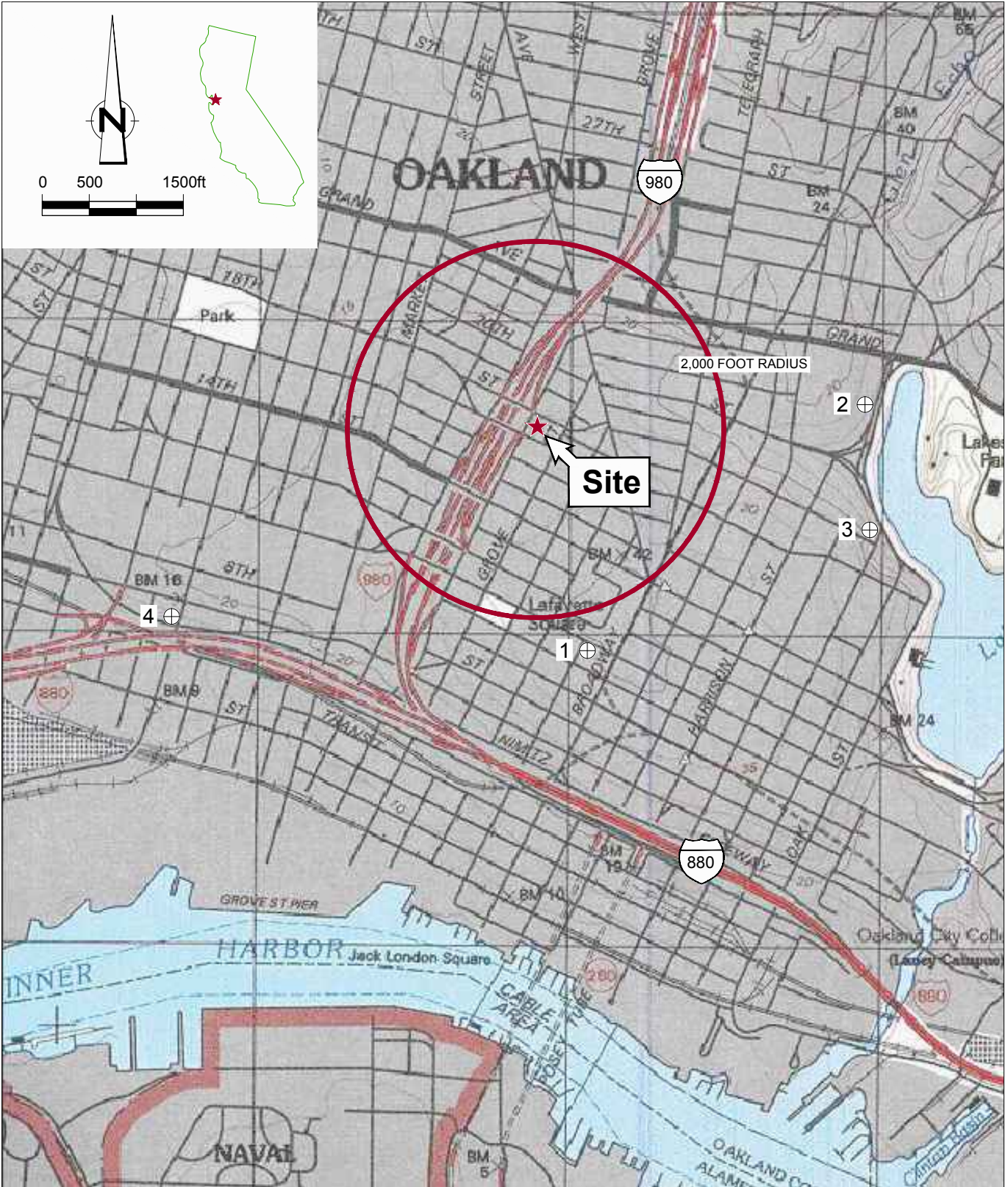

LEGEND

⊕ WATER SUPPLY WELL

Figure 10

**WATER SUPPLY WELL LOCATIONS
CHEVRON SERVICE STATION 94800
1700 CASTRO STREET
Oakland, California**



TABLES

TABLE 1

SOIL ANALYTICAL DATA
CHEVRON SERVICE STATION 94800
1700 CASTRO STREET, OAKLAND, CALIFORNIA

<i>Sample ID</i>	<i>Date</i>	<i>Depth (fbg)</i>	<i>Waste Oil</i>	<i>TPHd</i>	<i>TPHg</i>	<i>Benzene</i>	<i>Toluene</i>	<i>Ethyl-benzene</i>	<i>Total Xylenes</i>	<i>MTBE</i>	<i>Oxygenates</i>	<i>Naphthalene</i>	<i>Lead</i>	<i>Notes</i>
Milligrams per kilogram (mg/kg)														
<i>Low Threat Policy Criteria - Direct Contact and Outdoor Air Exposure</i>														
<i>0 to 5 fbg, Residential - Direct Contact</i>			--	--	100	1.9	--	21	--	--	--	9.7	--	
<i>5 to 10 fbg, Residential - Outdoor Air</i>			--	--	100	2.8	--	32	--	--	--	9.7	--	
<i>0 to 5 fbg, C/I - Direct Contact</i>			--	--	100	8.2	--	89	--	--	--	45	--	
<i>5 to 10 fbg, C/I, Outdoor Air</i>			--	--	100	12	--	134	--	--	--	45	--	
<i>0 to 10 fbg, Utility Worker</i>			--	--	100	14	--	314	--	--	--	219	--	
<i>700-Gallon Heating Oil UST</i>														
#1	01/26/87	8	14	--	--	--	--	--	--	--	--	--	--	
<i>Product Line Samples</i>														
CT-1	02/18/97	4	--	30	180	2.6	9.0	3.2	18	--	--	--	--	
CT-2	02/18/97	4	--	1.9	6.7	0.27	0.50	0.18	1.1	--	--	--	--	
CT-3	02/18/97	4	--	220	550	15	32	17	81	--	--	--	--	
CT-4	02/18/97	4	--	<1.0	<1.0	0.016	0.0055	0.019	0.010	--	--	--	--	
CT-5	02/18/97	4	--	19	5.9	<0.025	<0.025	<0.025	0.036	--	--	--	--	
<i>Soil Borings</i>														
CB-1	02/22/97	6	--	37	890	3.0	25	13	92	--	--	--	--	
	02/22/97	10	--	3.2	48	1.3	3.1	0.68	4.3	--	--	--	--	
CB-2	02/22/97	6	--	1.0	<1.0	<0.0050	<0.0050	<0.0050	<0.0050	--	--	--	--	
	02/22/97	10	--	<1.0	<1.0	0.011	<0.0050	0.012	0.034	--	--	--	--	
CB-3	02/22/97	6	--	<1.0	1.0	0.0074	0.015	0.012	0.085	--	--	--	--	
	02/22/97	10	--	<1.0	<1.0	0.019	0.045	0.0071	0.039	--	--	--	--	
CB-4	02/21/97	4	--	<1.0	<1.0	<0.0050	<0.0050	<0.0050	<0.0050	--	--	--	--	
	02/21/97	10	--	<1.0	<1.0	0.018	<0.0050	<0.0050	<0.0050	--	--	--	--	
CB-5	02/22/97	4	--	3.5	1.9	0.018	<0.0050	0.012	0.039	--	--	--	--	
	02/22/97	10	--	<1.0	<1.0	<0.0050	<0.0050	<0.0050	<0.0050	--	--	--	--	
CB-6	02/21/97	5	--	3.0	2.6	0.12	0.022	0.054	0.19	--	--	--	--	
	02/21/97	10	--	640	200	0.96	1.9	1.5	9.1	--	--	--	--	
CB-7	02/21/97	4	--	<1.0	<1.0	<0.0050	<0.0050	<0.0050	<0.0050	--	--	--	--	
	02/21/97	10	--	<1.0	<1.0	0.049	<0.0050	<0.0050	0.015	--	--	--	--	
CB-8	02/21/97	4	--	<1.0	<1.0	<0.0050	<0.0050	<0.0050	<0.0050	--	--	--	--	

TABLE 1

SOIL ANALYTICAL DATA
CHEVRON SERVICE STATION 94800
1700 CASTRO STREET, OAKLAND, CALIFORNIA

<i>Sample ID</i>	<i>Date</i>	<i>Depth (fbg)</i>	<i>Waste Oil</i>	<i>TPHd</i>	<i>TPHg</i>	<i>Benzene</i>	<i>Toluene</i>	<i>Ethyl- benzene</i>	<i>Total Xylenes</i>	<i>MTBE</i>	<i>Oxygenates</i>	<i>Naph- thalene</i>	<i>Lead</i>	<i>Notes</i>
													Milligrams per kilogram (mg/kg)	
<i>Low Threat Policy Criteria - Direct Contact and Outdoor Air Exposure</i>														
<i>0 to 5 fbg, Residential - Direct Contact</i>			--	--	100	1.9	--	21	--	--	--	9.7	--	
<i>5 to 10 fbg, Residential - Outdoor Air</i>			--	--	100	2.8	--	32	--	--	--	9.7	--	
<i>0 to 5 fbg, C/I - Direct Contact</i>			--	--	100	8.2	--	89	--	--	--	45	--	
<i>5 to 10 fbg, C/I, Outdoor Air</i>			--	--	100	12	--	134	--	--	--	45	--	
<i>0 to 10 fbg, Utility Worker</i>			--	--	100	14	--	314	--	--	--	219	--	
	02/21/97	10	--	<1.0	<1.0	<0.0050	<0.0050	<0.0050	<0.0050	--	--	--	--	
CB-9	02/21/97	4	--	<1.0	<1.0	<0.0050	<0.0050	<0.0050	<0.0050	--	--	--	--	
	02/22/97	10	--	<1.0	<1.0	<0.0050	<0.0050	<0.0050	<0.0050	--	--	--	--	
CB-10	02/22/97	4	--	<1.0	<1.0	<0.0050	<0.0050	<0.0050	<0.0050	--	--	--	--	
	02/22/97	10	--	<1.0	<1.0	<0.0050	<0.0050	<0.0050	<0.0050	--	--	--	--	
CB-11	02/21/97	4	--	<1.0	<1.0	<0.0050	<0.0050	<0.0050	<0.0050	--	--	--	--	
	02/22/97	10	--	<1.0	<1.0	<0.0050	<0.0050	<0.0050	<0.0050	--	--	--	--	
CB-12	02/21/97	4	--	<1.0	<1.0	0.098	<0.0050	<0.0050	<0.0050	--	--	--	--	
	02/22/97	10	--	<1.0	<1.0	0.18	0.0065	<0.0050	0.017	--	--	--	--	
<i>Monitoring Wells</i>														
MW-1	05/29/97	6	--	<1.0	<1.0	0.034	<0.0050	<0.0050	0.0068	<0.025	--	--	--	
	05/29/97	11	--	<1.0	<1.0	0.12	<0.0050	<0.0050	0.022	<0.025	--	--	--	
	05/29/97	16	--	<1.0	<1.0	0.026	0.020	<0.0050	0.020	<0.025	--	--	--	
	05/29/97	21	--	<1.0	<1.0	0.023	0.039	0.010	0.065	<0.025	--	--	--	
MW-2	05/29/97	6	--	<1.0	<1.0	<0.0050	<0.0050	<0.0050	<0.0050	<0.025	--	--	--	
	05/29/97	11	--	<1.0	<1.0	<0.0050	<0.0050	<0.0050	<0.0050	0.10	--	--	--	
	05/29/97	16	--	<1.0	<1.0	<0.0050	<0.0050	<0.0050	<0.0050	0.39	--	--	--	
	05/29/97	21	--	1.9	<1.0	<0.0050	<0.0050	<0.0050	<0.0050	0.58	--	--	--	
MW-3	05/29/97	6	--	<1.0	<1.0	<0.0050	<0.0050	<0.0050	<0.0050	<0.025	--	--	--	
	05/29/97	11	--	<1.0	<1.0	0.021	0.0063	<0.0050	0.0072	0.077	--	--	--	
	05/29/97	16	--	1.1	<1.0	0.026	0.032	<0.0050	0.026	0.11	--	--	--	
	05/29/97	21	--	<1.0	<1.0	0.0069	0.012	<0.0050	0.011	0.041	--	--	--	
MW-4	03/23/99	6	--	--	<1.00	<0.0050	<0.0050	<0.0050	<0.0050	0.22	--	--	--	
	03/23/99	16	--	--	<1.00	<0.0050	<0.0050	<0.0050	<0.0050	<0.0050	--	--	--	
	03/23/99	23	--	--	<1.00	0.0051	<0.0050	<0.0050	<0.0050	0.45	--	--	--	

TABLE 1

SOIL ANALYTICAL DATA
CHEVRON SERVICE STATION 94800
1700 CASTRO STREET, OAKLAND, CALIFORNIA

<i>Sample ID</i>	<i>Date</i>	<i>Depth (fbg)</i>	<i>Waste Oil</i>	<i>TPHd</i>	<i>TPHg</i>	<i>Benzene</i>	<i>Toluene</i>	<i>Ethyl-benzene</i>	<i>Total Xylenes</i>	<i>MTBE</i>	<i>Oxygenates</i>	<i>Naphthalene</i>	<i>Lead</i>	<i>Notes</i>
													Milligrams per kilogram (mg/kg)	
<i>Low Threat Policy Criteria - Direct Contact and Outdoor Air Exposure</i>														
<i>0 to 5 fbg, Residential - Direct Contact</i>			--	--	100	1.9	--	21	--	--	--	9.7	--	
<i>5 to 10 fbg, Residential - Outdoor Air</i>			--	--	100	2.8	--	32	--	--	--	9.7	--	
<i>0 to 5 fbg, C/I - Direct Contact</i>			--	--	100	8.2	--	89	--	--	--	45	--	
<i>5 to 10 fbg, C/I, Outdoor Air</i>			--	--	100	12	--	134	--	--	--	45	--	
<i>0 to 10 fbg, Utility Worker</i>			--	--	100	14	--	314	--	--	--	219	--	
MW-5	03/23/99	16	--	--	<1.00	<0.0050	<0.0050	<0.0050	<0.0050	<0.0050	--	--	--	
	03/23/99	24	--	--	<1.00	<0.0050	<0.0050	<0.0050	<0.0050	<0.0050	--	--	--	
MW-6	03/23/99	16	--	--	<1.00	<0.0050	<0.0050	<0.0050	<0.0050	<0.0050	--	--	--	
	03/23/99	21	--	--	<1.00	<0.0050	<0.0050	<0.0050	<0.0050	<0.0050	--	--	--	
MW-7	03/30/01	6	--	<1.0	<1.0	<0.005	<0.005	<0.005	<0.005	<0.05	--	--	--	
	03/30/01	10	--	<1.0	<1.0	<0.005	<0.005	<0.005	<0.005	<0.05	--	--	--	
	03/30/01	15	--	1.5	<1.0	<0.005	<0.005	<0.005	<0.005	<0.05	--	--	--	
	03/30/01	19.5	--	<1.0	<1.0	<0.005	<0.005	<0.005	<0.005	<0.05	--	--	--	
	03/30/01	24.5	--	<1.0	<1.0	<0.005	<0.005	<0.005	<0.005	<0.05	--	--	--	
<i>Soil Profile Borings</i>														
Comp-1 (B-1)	03/05/04		--	--	<1.0	<0.005	<0.005	<0.005	<0.02	<0.05	--	--	3.57	
Comp-2 (B-2)	03/05/04		--	--	<1.0	<0.005	<0.005	<0.005	<0.02	<0.05	--	--	3.41	
Comp-3 (B-3)	03/05/04		--	--	<1.0	<0.005	<0.005	<0.005	<0.02	<0.05	--	--	3.70	
Comp-4 (B-4)	03/05/04		--	--	<1.0	<0.005	<0.005	<0.005	<0.02	<0.05	--	--	4.02	
<i>Product Line Trench Sampling</i>														
P-1 @ 6'	04/08/04	6	--	1.5	3.1	<0.1	<0.1	<0.1	0.28	2.6	1.2 ^o	<0.1	5.2	
P-2 @ 5'	04/08/04	5	--	<1	<1	<0.005	<0.005	<0.005	<0.005	0.039	0.0056 ^c	<0.005	5.5	
P-3 @ 5'	04/08/04	5	--	93	200	1.9	2.3	5.5	25	12	ND	2.2	5.6	Over-excavated on
P-3 @ 10'	04/08/04	10	--	45	110	1.2	3.2	3.1	15	19	ND	1.2	<5.0	Over-excavated on
P-4 @ 4'	04/08/04	4	--	<1	<1	<0.005	<0.005	<0.005	<0.005	0.2	0.073 ^o	<0.005	5.3	
P-5 @ 6'	04/08/04	6	--	<1	<1	<0.025	<0.025	<0.025	<0.025	0.7	0.27 ^o	<0.025	<5.0	
P-6 @ 5'	04/08/04	5	--	1.9	<1	<0.005	<0.005	<0.005	<0.005	0.046	ND	<0.005	5.7	
P-7 @ 6'	04/08/04	6	--	<1	<1	<0.005	<0.005	<0.005	<0.005	0.6	ND	<0.050	<5.0	
P-8 @ 4'	04/08/04	4 ^a	--	54	8.3	<0.005	<0.005	<0.005	<0.005	0.045	0.12 ^o	<0.005	6.1	
P-9 @ 5'	04/08/04	5	--	<1	<1	<0.020	<0.020	<0.020	<0.020	0.27	ND	<0.020	7.4	
P-3 @ 12'	04/13/04	12	--	<1.0	<1.0	<0.005	<0.005	<0.005	<0.005	2.2	ND	--	6.4	Over-excavated on

TABLE 1

SOIL ANALYTICAL DATA
CHEVRON SERVICE STATION 94800
1700 CASTRO STREET, OAKLAND, CALIFORNIA

<i>Sample ID</i>	<i>Date</i>	<i>Depth (fbg)</i>	<i>Waste Oil</i>	<i>TPHd</i>	<i>TPHg</i>	<i>Benzene</i>	<i>Toluene</i>	<i>Ethylbenzene</i>	<i>Total Xylenes</i>	<i>MTBE</i>	<i>Oxygenates</i>	<i>Naphthalene</i>	<i>Lead</i>	<i>Notes</i>
<i>Milligrams per kilogram (mg/kg)</i>														
<i>Low Threat Policy Criteria - Direct Contact and Outdoor Air Exposure</i>														
<i>0 to 5 fbg, Residential - Direct Contact</i>			--	--	100	1.9	--	21	--	--	--	9.7	--	
<i>5 to 10 fbg, Residential - Outdoor Air</i>			--	--	100	2.8	--	32	--	--	--	9.7	--	
<i>0 to 5 fbg, C/I - Direct Contact</i>			--	--	100	8.2	--	89	--	--	--	45	--	
<i>5 to 10 fbg, C/I, Outdoor Air</i>			--	--	100	12	--	134	--	--	--	45	--	
<i>0 to 10 fbg, Utility Worker</i>			--	--	100	14	--	314	--	--	--	219	--	
P-10 @ 4'	04/13/04	4	--	<1.0	<1.0	<0.005	<0.005	<0.005	<0.005	0.62	0.33 ^{††}	--	<5.0	Over-excavated on
P-11 @ 4'	04/13/04	4	--	<1.0	<1.0	<0.005	<0.005	<0.005	<0.005	0.47	0.14 ^{††}	--	<5.0	Over-excavated on
P-3 @ 14'	04/15/04	14	--	<1.0	<1.0	<0.005	<0.005	<0.005	<0.005	2.8	ND	<0.1	6.6	
P-10 @ 12'	04/15/04	12	--	<1.0	<1.0	0.027	0.043	0.017	0.068	6.3	ND	<0.5	11	
P-11 @ 12'	04/15/04	12	--	<1.0	<1.0	<0.005	<0.005	<0.005	<0.005	2.6	ND	<0.1	9.1	
<i>Fuel UST Sampling</i>														
T-1 @ 14'	04/08/04	14	--	1.3	<1.0	<0.005	<0.005	<0.005	<0.005	<0.005	ND	<0.005	<5.0	
T-2 @ 14'	04/08/04	14	--	210	20	<0.005	<0.005	<0.005	<0.005	<0.005	ND	<0.005	<5.0	
T-3 @ 14'	04/08/04	14	--	710	13	<0.005	<0.005	<0.005	<0.005	<0.005	ND	<0.005	<5.0	
T-4 @ 14'	04/08/04	14	--	1,100	74	<0.005	<0.005	<0.005	<0.005	<0.005	ND	<0.005	<5.0	Over-excavated on
T-5 @ 14'	04/08/04	14	--	180	160	<0.1	<0.1	2.1	<0.1	<0.1	ND	2.2	5.9	
T-6 @ 14'	04/08/04	14	--	490	860	<2.0	<2.0	16	10	<2.0	ND	12	5.3	Over-excavated on
T-7 @ 14'	04/08/04	14	--	23	<1.0	<0.005	<0.005	<0.005	<0.005	<0.005	ND	<0.005	<5.0	
T-8 @ 14'	04/08/04	14	--	1,700	170	<0.005	<0.005	<0.005	<0.005	0.021	ND	0.09	<5.0	Over-excavated on
T-4 @ 20'	04/12/04	20	--	6,200	520	<0.050	<0.050	0.18	0.47	0.092	0.055 ^{††} ,0.050 ^c	--	<5.0	
T-6 @ 20'	04/12/04	20	--	990	190	<0.050	0.13	0.32	0.61	0.15	0.24 ^{††} ,0.013 ^c	--	<5.0	
T-8 @ 20'	04/12/04	20	--	2,800	160	<0.050	<0.050	0.050	<0.050	0.17	0.16 ^{††} ,0.011 ^c	--	<5.0	

Notes:

Total petroleum hydrocarbons as diesel (TPHd) analyzed by EPA Method 8015B.

Total petroleum hydrocarbons as gasoline (TPHg) analyzed by EPA Method 8015B modified.

Benzene, toluene, ethylbenzene, and xylenes (BTEX); methyl tertiary-butyl ether (MTBE); t-butyl alcohol (TBA); di-isopropyl ether (DIPE); ethyl tertiary-butyl ether (ETBE); t-amyl methyl ether (TAME); 1,2-dichloroethane (1,2-DCA); 1,2-dibromoethane (EDB) analyzed by EPA Method 8020 (from 1997-1999) and EPA Method 8260 (from 2001-2004).

Oxygenates by EPA Method 8260B

Lead by modified EPA Method 6010

TABLE 1

SOIL ANALYTICAL DATA
 CHEVRON SERVICE STATION 94800
 1700 CASTRO STREET, OAKLAND, CALIFORNIA

Sample ID	Date	Depth (fbg)	Waste Oil	TPHd	TPHg	Benzene	Toluene	Ethyl- benzene	Total Xylenes	MTBE	Oxygenates	Naph- thalene	Lead	Notes
<i>Low Threat Policy Criteria - Direct Contact and Outdoor Air Exposure</i>														
0 to 5 fbg, Residential - Direct Contact	--	--	100	1.9	--	21	--	--	--	--	9.7	--		
5 to 10 fbg, Residential - Outdoor Air	--	--	100	2.8	--	32	--	--	--	--	9.7	--		
0 to 5 fbg, C/I - Direct Contact	--	--	100	8.2	--	89	--	--	--	--	45	--		
5 to 10 fbg, C/I, Outdoor Air	--	--	100	12	--	134	--	--	--	--	45	--		
0 to 10 fbg, Utility Worker	--	--	100	14	--	314	--	--	--	--	219	--		

Naphthalene by EPA Method 8260

fbg = feet below grade.

ESLs = Environmental Screening Levels for soil < 3m bgs in a commercial setting (Table A) from Environmental Screening for Sites

<x = Not detected at reporting limit x.

ND=not detected

a = Field error when labeling the sample container. Label indicates sample was collected at 12 fbg. Sample was actually collected at 4 fbg.

b = Tertiary butyl alcohol (TBA)

c = Tertiary-amyl methyl ether (TAME)

**WELL CONSTRUCTION SPECIFICATIONS
CHEVRON SERVICE STATION 94800
1700 CASTRO STREET, OAKLAND, CALIFORNIA**

<i>Well ID</i>	<i>Date Installed</i>	<i>TOC</i>	<i>Total Depth (fbg)</i>	<i>Borehole Diameter (inches)</i>	<i>Casing Diameter* (inches)</i>	<i>Slot Size (inches)</i>	<i>Screen Interval (fbg)</i>	<i>Filter Pack (fbg)</i>	<i>Status</i>
MW-1	5/29/1997	34.01	31.5	8	2	0.010	10.5-30.5	9-30.5	Active
MW-2	5/29/1997	32.59	31.5	8	2	0.010	10.5-30.5	9-30.5	Active
MW-3	5/29/1997	34.16	31.5	8	2	0.010	10.5-30.5	9-30.5	Active
MW-4	3/23/1999	33.07	30	8	2	0.010	10.5-28.5	8-28.5	Active
MW-5	3/23/1999	30.93	30	8	2	0.010	10.5-28.5	8-28.5	Destroyed
MW-6	3/23/1999	30.58	30	8	2	0.010	10.5-28.5	8-28.5	Destroyed
MW-7	3/30/2001	34.35	30	8	2	0.010	10-30	9-30	Active

Abbreviations & Notes

TOC = Top of casing elevation (feet above mean sea level)

fbg = Feet below grade

* = Casing material: Schedule 40 PVC

NA = Not available

TABLE 3

**WATER SUPPLY WELL SURVEY
CHEVRON SERVICE STATION 94800
1700 CASTRO STREET, OAKLAND, CALIFORNIA**

Well No.	Owner	Location	Type	Year Installed	Distance From Site (feet)	Direction From Site	
1	291733	Bramalea Pacific, Inc.	1111 Broadway, Oakland	Irrigation	1990	2,200	South
2	345857	Kaiser Center, Inc.	300 Lakeside Drive, Oakland	Irrigation	1991	3,200	East
3	32543	Lakeside Corporation	244 Lakeside, Oakland	Irrigation	1977	3,400	East
4	33557	Universal Foods Corporation	1384 Fifth Street, Oakland	Industrial	1969	5,300	Southwest
5	33752	Oakland School District	Unknown	Irrigation	Unknown	Unknown	Unknown

TABLE 4
SENSITIVE RECEPTOR SURVEY
CHEVRON SERVICE STATION 94800
1700 CASTRO STREET, OAKLAND, CALIFORNIA

Name	Address	Distance Feet	Direction
<u>Schools</u>			
Oakland School for the Arts	530 18th Street, Oakland	1,200	East
Envision Academy of Arts and Technology	1515 Webster Street, Oakland	2,500	Southeast
Lafayette Elementary School	1700 Market Street, Oakland	1,000	West
KIPP Bridge Charter School	991 14th St, Oakland, CA 94607	1,600	Southwest
Martin Luther King Junior Elementary	960 10th St, Oakland, CA 94607†	2,000	Southwest
<u>Hospitals</u>			
None			
<u>Daycares</u>			
YMCA	756 21st Street, Oakland	1,000	North
Marjorie Family Daycare and Preschool	788 14Th Street, Oakland	1,100	Southwest
<u>Elder Care</u>			
The San Pablo Senior Residential Community	1955 San Pablo Avenue, Oakland	550	Northeast
<u>Surface Waters</u>			
Lake Merritt		2,500	East
Inner Oakland Harbor		3,000	South

APPENDIX A

REGULATORY EMAIL

Hoey, Kiersten

From: Detterman, Mark, Env. Health [Mark.Detterman@acgov.org]
Sent: Thursday, August 15, 2013 4:42 PM
To: Hoey, Kiersten; 'espino@chevron.com'
Cc: Roe, Dilan, Env. Health
Subject: RE: RO0342 Well Completion Request and Request for Data Gap Work Plan, Focused SCM, Preferential Pathway Survey, and Path to Closure Schedule
Attachments: RO342_Signed_DWR_Form.pdf; Attachment B Site Conceptual Model.pdf; Attachment C Path to Closure Project Schedule.pdf; Attachment A Preferential Pathway and Sensitive Receptor Survey.pdf

Kiersten,

Here's the signed DWR form. Please also forward a signed copy of the Alameda County Dept of Public Works well survey form as the two databases are different enough to get interesting results, and thus will capture a more complete well record of a location. ACEH is in agreement that both information sources will help move the case along a path towards closure. In order to expedite that path, ACEH requests the information be submitted in a focused Site Conceptual Model that identifies site data gaps, evaluates potential conduits (utilities and wells – already captured above), evaluates the site under the Low Threat Closure Policy, includes a Data Gap Work Plan as needed, and details a Path to Closure Schedule. Initial LTCP reviews of cases are available on Geotracker. Please see Attachment A (Preferential Pathway and Sensitive Receptor Survey), Attachment B (Site Conceptual Model) and Attachment C (Path to Closure Schedule) for the requisite detail for these items.

TECHNICAL REPORT REQUEST

Please upload technical reports to the ACEH ftp site (Attention: Mark Detterman), and to the State Water Resources Control Board's Geotracker website, in accordance with the specified file naming convention below, according to the following schedule:

- **October 31, 2013** – Resulting Report
File to be named RO342_SCM / WP / RFC_R_yyyy-mm-dd (as appropriate)

These reports are being requested pursuant to California Health and Safety Code Section 25296.10. 23 CCR Sections 2652 through 2654, and 2721 through 2728 outline the responsibilities of a responsible party in response to an unauthorized release from a petroleum UST system, and require your compliance with this request.

Should you have questions, please let me know.

Mark Detterman
Senior Hazardous Materials Specialist, PG, CEG
Alameda County Environmental Health
1131 Harbor Bay Parkway
Alameda, CA 94502
Direct: 510.567.6876
Fax: 510.337.9335
Email: mark.detterman@acgov.org

PDF copies of case files can be downloaded at:

<http://www.acgov.org/aceh/lop/ust.htm>

From: Hoey, Kiersten [<mailto:khoey@croworld.com>]
Sent: Wednesday, August 14, 2013 2:58 PM
To: Detterman, Mark, Env. Health
Subject: RO0342 Well Completion Report Request form

Hi Mark,

Will you please sign and return the attached well completion request for RO0342 (Chevron Station 94800, 1700 Castro Street, Oakland), so that we can request well completion report from DWR within a 2,000 feet radius of the site.

Thank you,
Kiersten

Kiersten Hoey

Conestoga-Rovers & Associates

Address: 5900 Hollis Street, Suite A, Emeryville, CA 94608

Phone: 510-420-3347 Fax: 510-420-9170

Mobile: 916-919-0358

khoey@croworld.com

www.craworld.com

PLEASE THINK BEFORE YOU PRINT 

Perform every task the safe way, the right way, every time!



This communication and any accompanying document(s) are confidential and are intended for the sole use of the addressee. If you are not the intended recipient, please notify me at the telephone number shown above or by return e-mail and delete this e-mail and any copies. You are advised that any disclosure, copying, distribution, or the taking of any action in reliance upon the communication without consent is strictly prohibited. Thank you.



APPENDIX B

BORING LOGS

Gettler-Ryan Inc.

Log of Boring CB-1



PROJECT: <i>Chevron Service Station No. 9-4800</i>	LOCATION: <i>1700 Castro Street, Oakland, CA</i>
GSI PROJECT NO.: <i>6383.01</i>	CASING ELEVATION:
DATE STARTED: <i>2/22/97</i>	WL (ft. bgs): DATE: TIME:
DATE FINISHED: <i>2/22/97</i>	WL (ft. bgs): DATE: TIME:
DRILLING METHOD: <i>4" hand-auger</i>	TOTAL DEPTH: <i>10 Feet</i>
DRILLING COMPANY:	GEOLOGIST: <i>Clyde Galantine</i>

DEPTH feet	PID (ppm)	BLOWS/FT. *	SAMPLE NUMBER	SAMPLE INT.	GRAPHIC LOG	SOIL CLASS	GEOLOGIC DESCRIPTION	REMARKS
							Excavation.	
5			CB-1-6			SM	SILTY SAND (SM) - dark yellowish brown (10YR 4/4), moist, 70% fine to medium sand, 30% fines, subangular to rounded.	
10			CB-1-10				Bottom of boring = 10 feet.	
15								
20								
25								
30								
35								

Gettler-Ryan Inc.

Log of Boring CB-2

PROJECT: <i>Chevron Service Station No. 9-4800</i>	LOCATION: <i>1700 Castro Street, Oakland, CA</i>
GSI PROJECT NO. : <i>6383.01</i>	CASING ELEVATION:
DATE STARTED: <i>2/22/97</i>	WL (ft. bgs): DATE: TIME:
DATE FINISHED: <i>2/22/97</i>	WL (ft. bgs): DATE: TIME:
DRILLING METHOD: <i>4" hand-auger</i>	TOTAL DEPTH: <i>10 Feet</i>
DRILLING COMPANY:	GEOLOGIST: <i>Clyde Galantine</i>

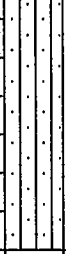
DEPTH feet	PID (ppm)	BLOWS/FT. *	SAMPLE NUMBER	SAMPLE INT.	GRAPHIC LOG	SOIL CLASS	GEOLOGIC DESCRIPTION	REMARKS
							Excavation.	
							Pea gravel.	
5			CT-2 (2/18/97)	█		SM	SILTY SAND (SM) - brown (10YR 4/3), moist, 85% fine to medium sand, 15% fines, subangular to rounded.	
			CB-2-6	█				
10			CB-2-10	█			Color change to dark yellowish brown (10YR 4/6), 80% fine to medium sand, 20% fines. Bottom of boring = 10 feet.	
15								
20								
25								
30								
35								

Gettler-Ryan Inc.

Log of Boring CB-3

PROJECT: *Chevron Service Station No. 9-4800*

LOCATION: *1700 Castro Street, Oakland, CA*

GSI PROJECT NO.: *6383.01*

CASING ELEVATION:

DATE STARTED: *2/22/97*

WL (ft. bgs): DATE: TIME:

DATE FINISHED: *2/22/97*





WL (ft. bgs): DATE: TIME:

DRILLING METHOD: *4" hand-auger*

TOTAL DEPTH: *10.25 Feet*

DRILLING COMPANY:

GEOLOGIST: *Clyde Galantine*

DEPTH feet	PID (ppm)	BLOWS/FT. *	SAMPLE NUMBER	SAMPLE INT.	GRAPHIC LOG	SOIL CLASS	GEOLOGIC DESCRIPTION	REMARKS
							Excavation.	
							Backfill material and debris.	
5			CT-2 (2/18/97)	█		SM	SILTY SAND (SM) - dark yellowish brown (10YR 4/4), moist, 85% fine to medium sand, 15% fines, subangular to rounded.	
			CB-2-6	█				
10			CB-2-10	█			80% fine to medium sand, 20% fines, oxide staining.	
							Bottom of boring = 10.25 feet.	
15								
20								
25								
30								
35								

Gettler-Ryan Inc.

Log of Boring CB-5

PROJECT: *Chevron Service Station No. 9-4800*

LOCATION: *1700 Castro Street, Oakland, CA*

GSI PROJECT NO.: *6383.01*

CASING ELEVATION:

DATE STARTED: *2/22/97*

WL (ft. bgs): DATE: TIME:

DATE FINISHED: *2/22/97*





WL (ft. bgs): DATE: TIME:

DRILLING METHOD: *4" hand-auger*

TOTAL DEPTH: *10 Feet*

DRILLING COMPANY:

GEOLOGIST: *Clyde Galantine*

DEPTH feet	PTD (ppm)	BLOWS/FT. *	SAMPLE NUMBER	SAMPLE INT.	GRAPHIC LOG	SOIL CLASS	GEOLOGIC DESCRIPTION	REMARKS
							Excavation.	
							Backfill and debris.	
							Fill sand.	
			CB-5-4			SM	SILTY SAND (SM) - yellowish brown (10YR 5/6), moist, 85% fine to medium sand, 15% fines, subangular to rounded, oxide staining.	
5								
			CB-5-10				Color change to (10YR 5/4), 80% fine to medium sand, 20% fines. Bottom of boring = 10 feet.	
10								
15								
20								
25								
30								
35								

Gettler-Ryan Inc.

Log of Boring CB-6

PROJECT: *Chevron Service Station No. 9-4800*

LOCATION: *1700 Castro Street, Oakland, CA*

GSI PROJECT NO. : *6383.01*

CASING ELEVATION:

DATE STARTED: *2/21/97*

WL (ft. bgs): DATE: TIME:

DATE FINISHED: *2/21/97*





WL (ft. bgs): DATE: TIME:

DRILLING METHOD: *4" hand-auger*

TOTAL DEPTH: *10 Feet*

DRILLING COMPANY:

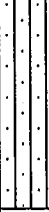
GEOLOGIST: *Clyde Galantine*

DEPTH feet	PID (ppm)	BLOWS/FT. *	SAMPLE NUMBER	SAMPLE INT.	GRAPHIC LOG	SOIL CLASS	GEOLOGIC DESCRIPTION	REMARKS
							Pavement.	
							Backfill material - soil, brick, concrete, wood.	
5			CB-6-5			SM	SILTY SAND (SM) - dark gray (10YR 4/1), moist, dense, 80% fine to medium sand, 20% fines, subangular to rounded.	
10			CB-6-10				Color change to dark grayish brown (2.5Y 4/2), 60% fine to medium sand, 40% fines. Bottom of boring = 10 feet.	
15								
20								
25								
30								
35								

Gettler-Ryan Inc.

Log of Boring CB-7

PROJECT: *Chevron Service Station No. 9-4800*

LOCATION: *1700 Castro Street, Oakland, CA*

GSI PROJECT NO.: *6383.01*

CASING ELEVATION:

DATE STARTED: *2/21/97*

WL (ft. bgs): DATE: TIME:

DATE FINISHED: *2/21/97*





WL (ft. bgs): DATE: TIME:

DRILLING METHOD: *4" hand-auger*

TOTAL DEPTH: *10 Feet*

DRILLING COMPANY:

GEOLOGIST: *Clyde Galantine*

DEPTH feet	PID (ppm)	BLOWS/FT. *	SAMPLE NUMBER	SAMPLE INT.	GRAPHIC LOG	SOIL CLASS	GEOLOGIC DESCRIPTION	REMARKS
							Pavement.	
							Backfill material and debris.	
5			CB-7-4			SM	SILTY SAND (SM) - dark yellowish brown (10YR 4/4), moist, 60% fine to medium sand, 40% fines, subangular to rounded, oxide staining.	
10			CB-7-10				65% fine to medium sand, 35% fines. Bottom of boring = 10 feet.	

Gettler-Ryan Inc.

Log of Boring CB-8

PROJECT: *Chevron Service Station No. 9-4800*

LOCATION: *1700 Castro Street, Oakland, CA*

GSI PROJECT NO.: *6383.01*

CASING ELEVATION:

DATE STARTED: *2/21/97*

WL (ft. bgs): DATE: TIME:

DATE FINISHED: *2/21/97*

WL (ft. bgs): DATE: TIME:

DRILLING METHOD: *4" hand-auger*

TOTAL DEPTH: *10 Feet*

DRILLING COMPANY:

GEOLOGIST: *Clyde Galantine*

DEPTH feet	PID (ppm)	BLOWS/FT. *	SAMPLE NUMBER	SAMPLE INT.	GRAPHIC LOG	SOIL CLASS	GEOLOGIC DESCRIPTION	REMARKS
							Pavement.	
							Fill material and debris.	
5			CB-8-4			SM	SILTY SAND (SM) - brown (10YR 5/3), moist, 65% fine to medium sand, 35% fines, subangular to rounded, oxide staining.	
10			CB-8-10				Color change to dark yellowish brown (10YR 3/4), 70% fine to medium sand, 30% fines.	
							Bottom of boring = 10 feet.	



Cambria Environmental Technology, Inc.
 5900 Hollis Street, Suite A
 Emeryville, CA 94608
 Telephone: 510-420-0700
 Fax: 510-420-9170

BORING / WELL LOG

CLIENT NAME	Chevron Products Company	BORING/WELL NAME	B1
JOB/SITE NAME	9-4800	DRILLING STARTED	05-Mar-04
LOCATION	1700 Castro Street, Oakland California	DRILLING COMPLETED	05-Mar-04
PROJECT NUMBER	61D-1966	WELL DEVELOPMENT DATE (YIELD)	NA
DRILLER	Woodward Drilling	GROUND SURFACE ELEVATION	NA
DRILLING METHOD	Hydraulic push	TOP OF CASING ELEVATION	NA
BORING DIAMETER	2"	SCREENED INTERVALS	NA
LOGGED BY	Dan Glaze	DEPTH TO WATER (First Encountered)	NA
REVIEWED BY	Tom Sparrowe	DEPTH TO WATER (Static)	NA
REMARKS	Vacuum cleared to 8 fbg		

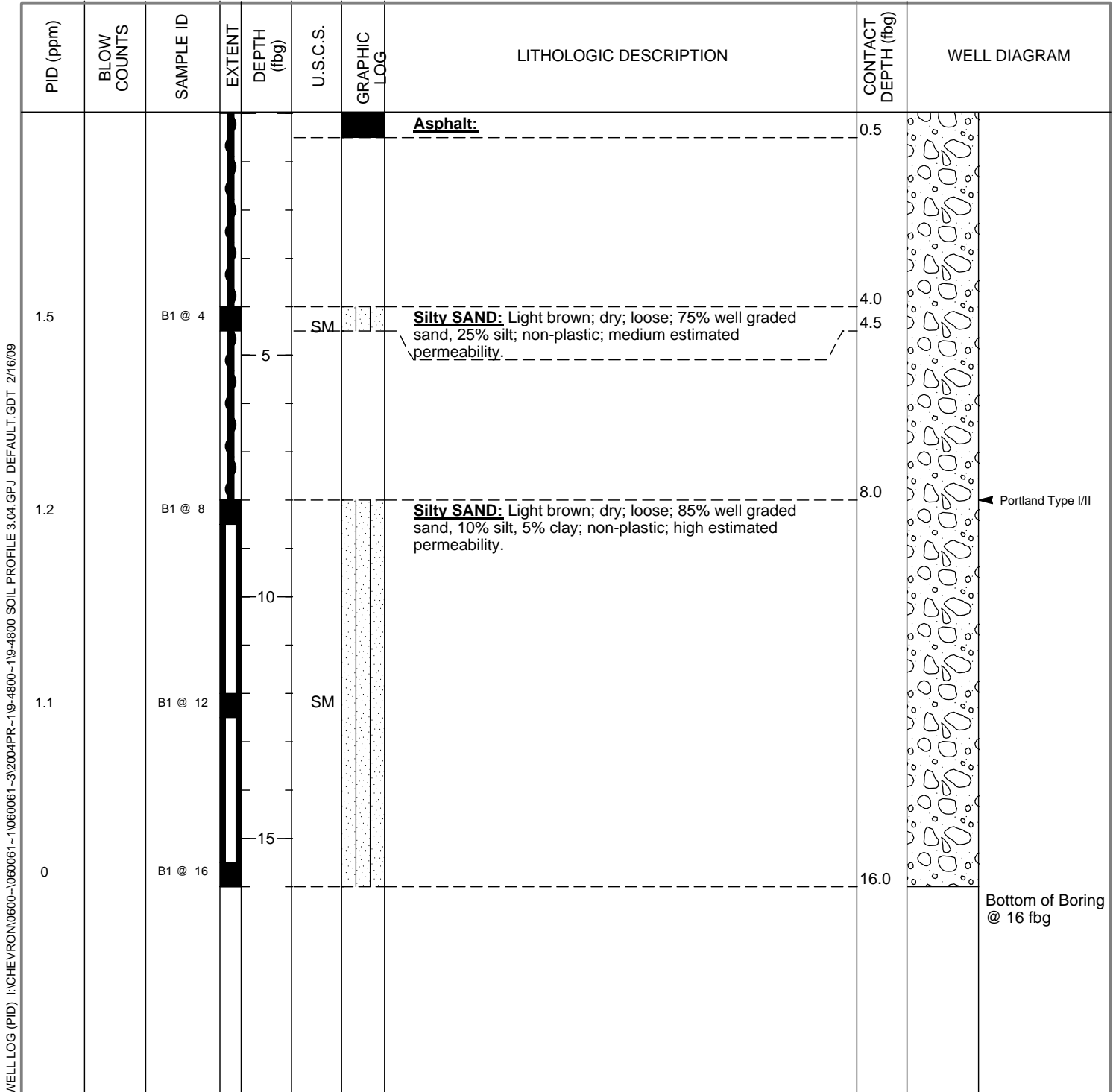



Cambria Environmental Technology, Inc.
 5900 Hollis Street, Suite A
 Emeryville, CA 94608
 Telephone: 510-420-0700
 Fax: 510-420-9170

BORING / WELL LOG

CLIENT NAME	Chevron Products Company	BORING/WELL NAME	B2
JOB/SITE NAME	9-4800	DRILLING STARTED	05-Mar-04
LOCATION	1700 Castro Street, Oakland California	DRILLING COMPLETED	05-Mar-04
PROJECT NUMBER	61D-1966	WELL DEVELOPMENT DATE (YIELD)	NA
DRILLER	Woodward Drilling	GROUND SURFACE ELEVATION	NA
DRILLING METHOD	Hydraulic push	TOP OF CASING ELEVATION	NA
BORING DIAMETER	2"	SCREENED INTERVALS	NA
LOGGED BY	Dan Glaze	DEPTH TO WATER (First Encountered)	NA
REVIEWED BY	Tom Sparrowe	DEPTH TO WATER (Static)	NA
REMARKS	Vacuum cleared		

WELL LOG (PID) I:\CHEVRON\0600--\060061-1\1060061-1\19-4800--19-4800 SOIL PROFILE 3.04.GPJ DEFAULT.GDT 2/16/09

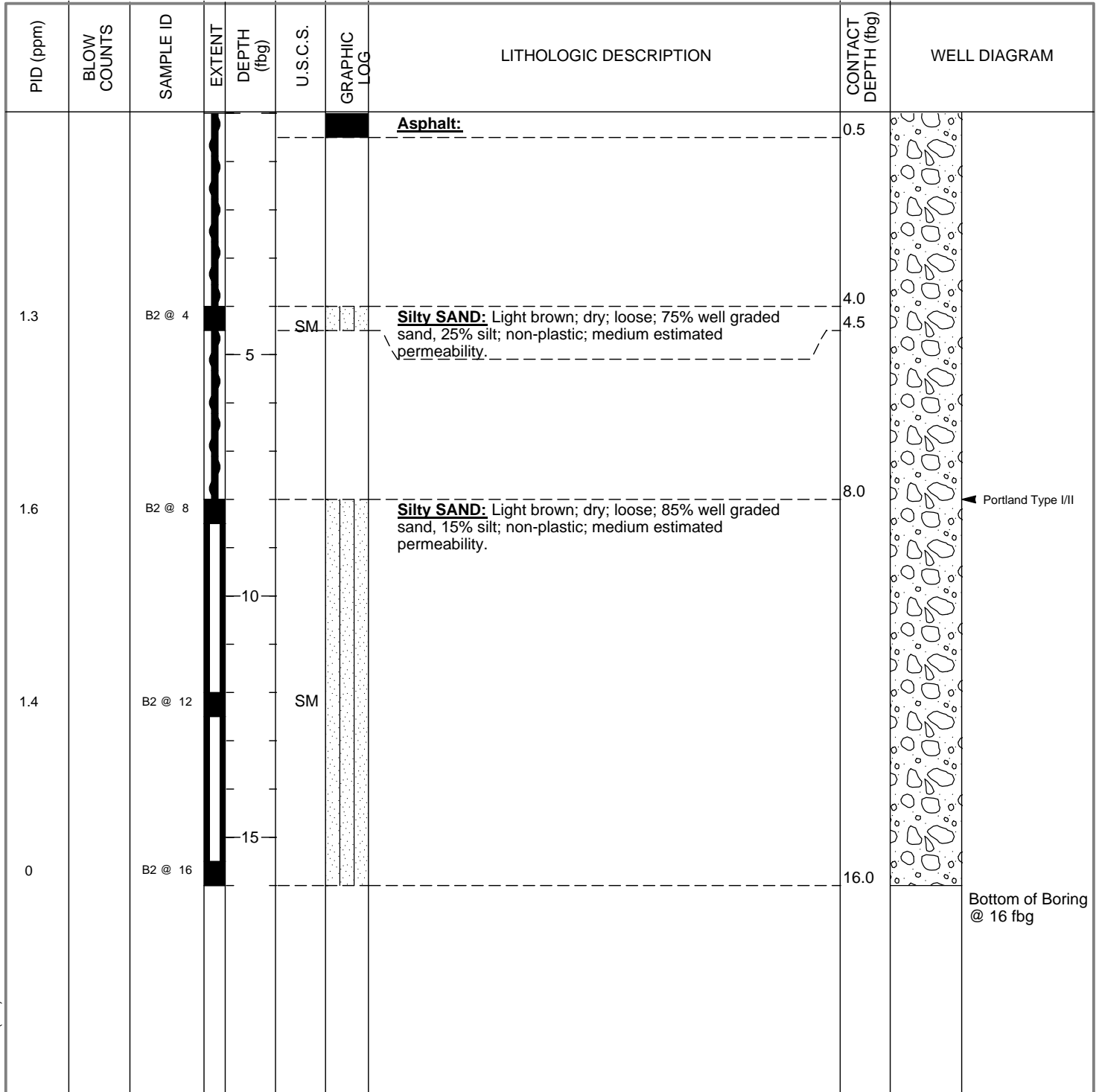



Cambria Environmental Technology, Inc.
 5900 Hollis Street, Suite A
 Emeryville, CA 94608
 Telephone: 510-420-0700
 Fax: 510-420-9170

BORING / WELL LOG

CLIENT NAME	Chevron Products Company	BORING/WELL NAME	B3
JOB/SITE NAME	9-4800	DRILLING STARTED	05-Mar-04
LOCATION	1700 Castro Street, Oakland California	DRILLING COMPLETED	05-Mar-04
PROJECT NUMBER	61D-1966	WELL DEVELOPMENT DATE (YIELD)	NA
DRILLER	Woodward Drilling	GROUND SURFACE ELEVATION	NA
DRILLING METHOD	Hydraulic push	TOP OF CASING ELEVATION	NA
BORING DIAMETER	2"	SCREENED INTERVALS	NA
LOGGED BY	Dan Glaze	DEPTH TO WATER (First Encountered)	NA
REVIEWED BY	Tom Sparrowe	DEPTH TO WATER (Static)	NA
REMARKS	Vacuum cleared		

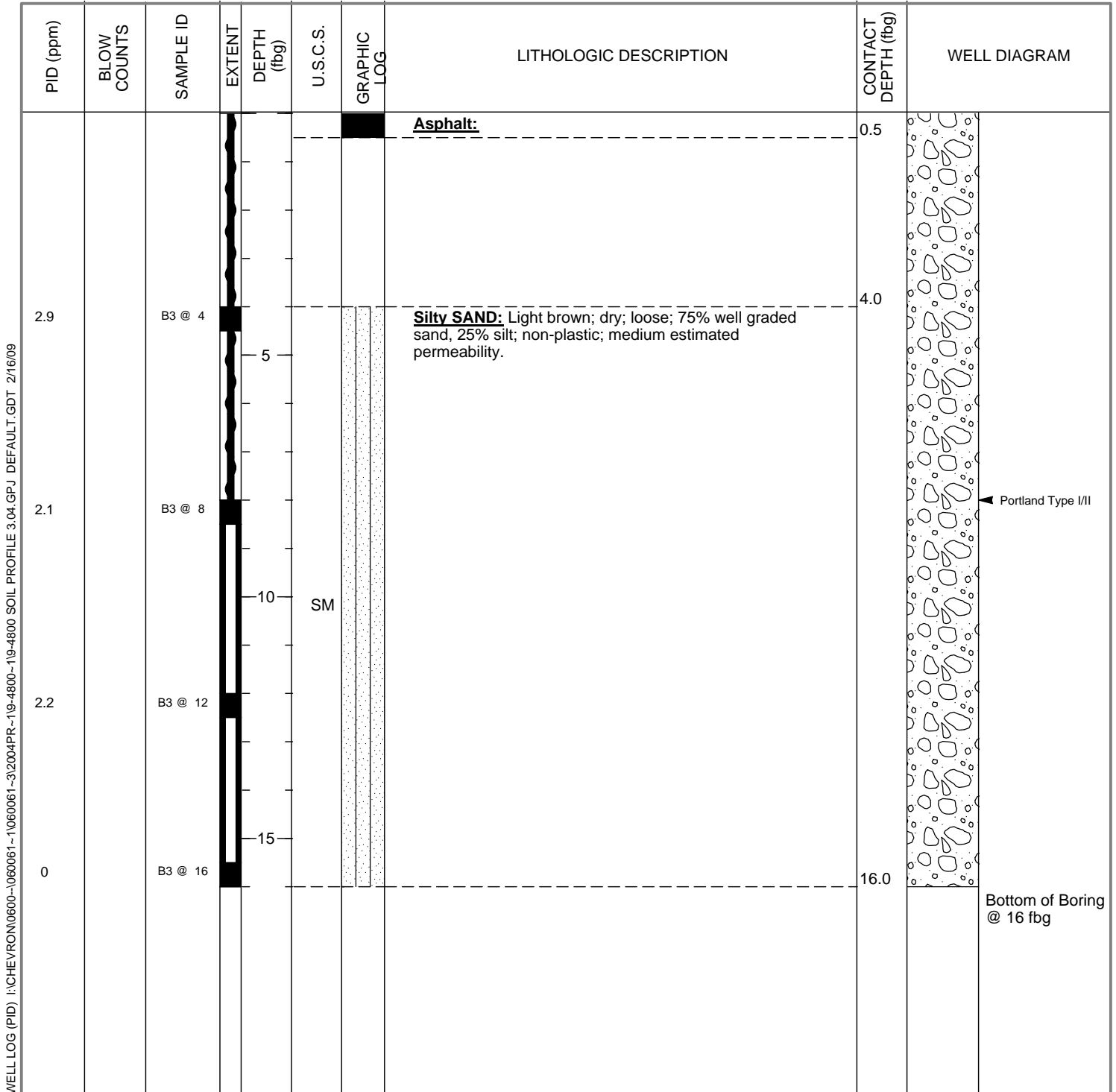



Cambria Environmental Technology, Inc.
 5900 Hollis Street, Suite A
 Emeryville, CA 94608
 Telephone: 510-420-0700
 Fax: 510-420-9170

BORING / WELL LOG

CLIENT NAME	<u>Chevron Products Company</u>	BORING/WELL NAME	<u>B4</u>
JOB/SITE NAME	<u>9-4800</u>	DRILLING STARTED	<u>05-Mar-04</u>
LOCATION	<u>1700 Castro Street, Oakland California</u>	DRILLING COMPLETED	<u>05-Mar-04</u>
PROJECT NUMBER	<u>61D-1966</u>	WELL DEVELOPMENT DATE (YIELD)	<u>NA</u>
DRILLER	<u>Woodward Drilling</u>	GROUND SURFACE ELEVATION	<u>NA</u>
DRILLING METHOD	<u>Hydraulic push</u>	TOP OF CASING ELEVATION	<u>NA</u>
BORING DIAMETER	<u>2"</u>	SCREENED INTERVALS	<u>NA</u>
LOGGED BY	<u>Dan Glaze</u>	DEPTH TO WATER (First Encountered)	<u>NA</u>
REVIEWED BY	<u>Tom Sparrowe</u>	DEPTH TO WATER (Static)	<u>NA</u>
REMARKS	<u>Vacuum cleared</u>		

WELL LOG (PID) I:\CHEVRON\0600--\060061-1\1060061-1\19-4800--1\9-4800 SOIL PROFILE 3.04.GPJ DEFAULT.GDT 2/16/09

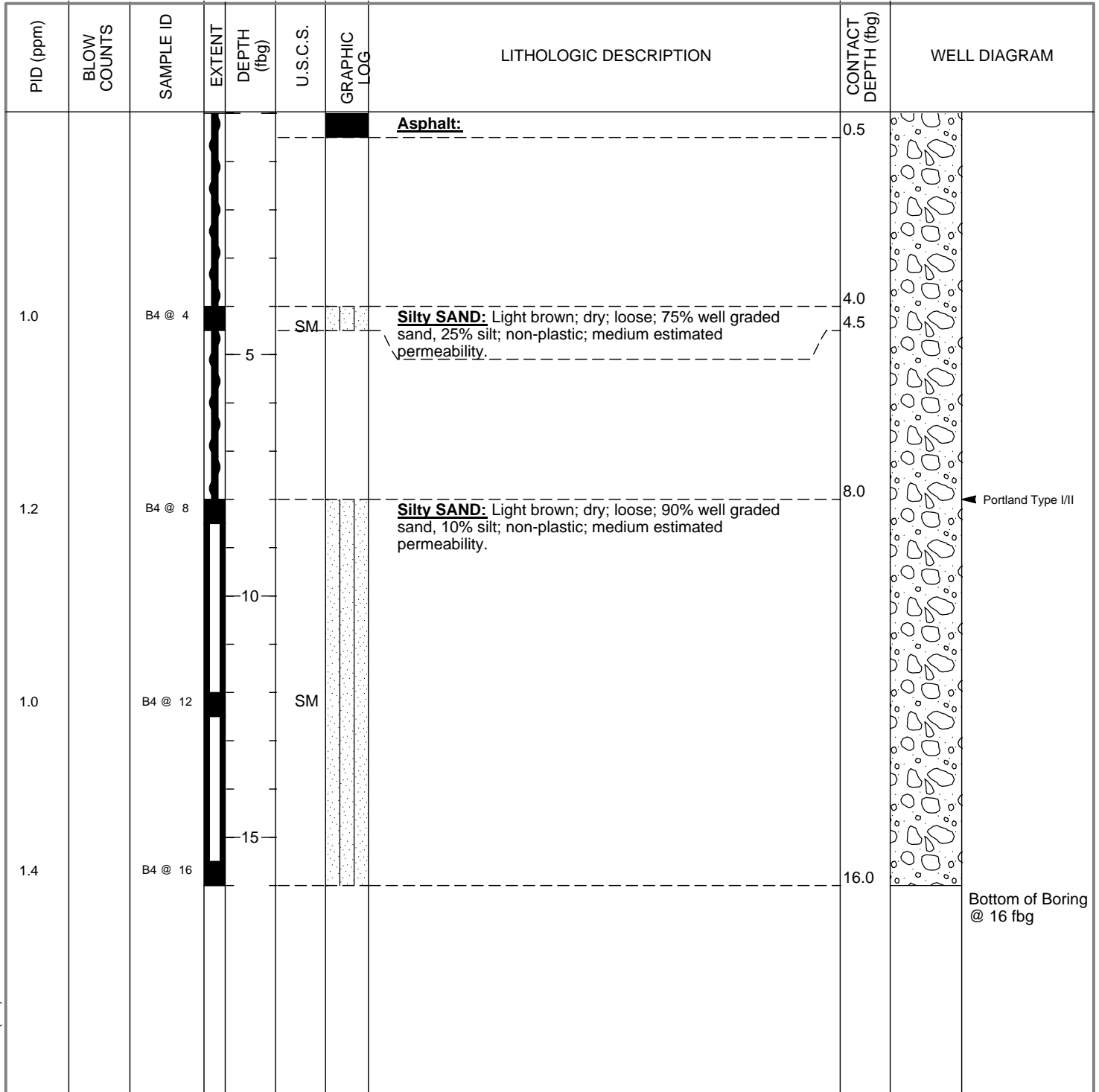

Gettler-Ryan, Inc.

Log of Boring MW-1

PROJECT: <i>Chevron SS# 9-4800</i>	LOCATION: <i>1700 Castro Street, Oakland, CA</i>
G-R PROJECT NO.: <i>6383.01</i>	SURFACE ELEVATION: <i>30.75 feet MSL</i>
DATE STARTED: <i>05/29/97</i>	WL (ft. bgs): <i>25.00</i> DATE: <i>05/29/97</i> TIME: <i>16:45</i>
DATE FINISHED: <i>05/29/97</i>	WL (ft. bgs): <i>25.00</i> DATE: <i>05/29/97</i> TIME: <i>18:30</i>
DRILLING METHOD: <i>8 in. Hollow Stem Auger</i>	TOTAL DEPTH: <i>31.5 Feet</i>
DRILLING COMPANY: <i>Bay Area Exploration, Inc.</i>	GEOLOGIST: <i>Barbara Sieminski</i>

DEPTH feet	PID (ppm)	BLOWS/FT. *	SAMPLE NUMBER	SAMPLE INT. GRAPHIC LOG	SOIL CLASS	GEOLOGIC DESCRIPTION	WELL DIAGRAM
						PAVEMENT - asphalt over baserock.	
5	21	15	MW1-6		SM	SILTY SAND (SM) - very dark grayish brown (10YR 3/2), damp, medium dense; 70% fine sand, 30% silt; pieces of brick and wood; fill.	
					SC	CLAYEY SAND (SC) - dark yellowish brown (10YR 4/6) mottled grayish brown (10YR 5/2), moist, medium dense; 60% fine to medium sand, 40% clay.	
10	12	16	MW1-11		SM	SILTY SAND (SM) - yellowish brown (10YR 5/4) mottled grayish brown (10YR 5/2), moist, medium dense; 80% fine to medium sand, 15% silt, 5% clay.	
15	123	42	MW1-16		SP	SAND (SP) - light olive brown (2.5Y 5/6), moist, dense; 100% fine sand	
20	104	40	MW1-21				
25	0	39	MW1-26			∇∇ Color changes to grayish brown (2.5Y 5/2); becomes saturated at 25 feet.	
30	0	12	MW1-31		CL	CLAY (CL) - grayish brown (2.5Y 5/2), moist, stiff, low plasticity; 90% clay, 10% fine sand.	
35						(* = converted to equivalent standard penetration blows/ft.)	

Gettler-Ryan, Inc.

Log of Boring MW-2

PROJECT: Chevron SS# 9-4800

LOCATION: 1700 Castro Street, Oakland, CA

G-R PROJECT NO.: 6383.01

SURFACE ELEVATION: 30.00 feet MSL

DATE STARTED: 05/29/97

WL (ft. bgs): 24.00 DATE: 05/29/97 TIME: 11:20

DATE FINISHED: 05/29/97

WL (ft. bgs): 24.00 DATE: 05/29/97 TIME: 13:00

DRILLING METHOD: 8 in. Hollow Stem Auger

TOTAL DEPTH: 31.5 Feet

DRILLING COMPANY: Bay Area Exploration, Inc.

GEOLOGIST: Barbara Sieminski

DEPTH feet	PIID (ppm)	BLOWS/FT. *	SAMPLE NUMBER	SAMPLE INT.	GRAPHIC LOG	SOIL CLASS	GEOLOGIC DESCRIPTION	WELL DIAGRAM
							PAVEMENT - asphalt over baserock.	
5	15	12	MW2-6			SM	SILTY SAND (SM) - very dark grayish brown (10YR 3/2), damp, medium dense; 60% fine sand, 40% silt; pieces of brick; fill.	
						SM	SILTY SAND (SM) - grayish brown (10YR 5/2), moist, medium dense; 70% fine sand, 30% silt.	
						SC	Color changes to olive gray (5Y 5/2) at 5 feet.	
						SC	CLAYEY SAND (SC) - brown (10YR 5/4), damp, medium dense; 60% fine sand, 40% clay.	
10	26	22	MW2-11			SM	SILTY SAND (SM) - yellowish brown (10YR 5/4), moist, medium dense; 85% fine to medium sand, 15% silt.	
15	29	34	MW2-16			SP	SAND (SP) - yellowish brown (10YR 5/4), moist, dense; 95% fine to medium sand, 5% silt.	
							Color changes to olive gray (5Y 4/2) at 15.5 feet.	
20	32	44	MW2-21					
25	1.3	43	MW2-25.5				▼▼ Becomes saturated at 24 feet. 100% fine to medium sand at 25 feet.	
30	0	13	MW2-31			CL	CLAY (CL) - grayish brown (2.5Y 5/2), moist, stiff, low plasticity; 90% clay, 10% fine sand.	
35							(* = converted to equivalent standard penetration blows/ft.)	

Gettler-Ryan, Inc.

Log of Boring MW-3

PROJECT: Chevron SS# 9-4800

LOCATION: 1700 Castro Street, Oakland, CA

G-R PROJECT NO.: 6383.01

SURFACE ELEVATION: 31.32 feet MSL

DATE STARTED: 05/29/97

WL (ft. bgs): 25.00 DATE: 05/29/97 TIME: 14:00

DATE FINISHED: 05/29/97

WL (ft. bgs): 25.00 DATE: 05/29/97 TIME: 15:30

DRILLING METHOD: 8 in. Hollow Stem Auger

TOTAL DEPTH: 31.5 Feet

DRILLING COMPANY: Bay Area Exploration, Inc.

GEOLOGIST: Barbara Sieminski

DEPTH feet	PID (ppm)	BLOWS/FT. *	SAMPLE NUMBER	SAMPLE INT.	GRAPHIC LOG	SOIL CLASS	GEOLOGIC DESCRIPTION	WELL DIAGRAM
							PAVEMENT - asphalt over baserock.	
						SM	SILTY SAND (SM) - very dark grayish brown (10YR 3/2), damp, medium dense; 70% fine sand, 30% silt; trace gravel; fill.	
						SM	SILTY SAND (SM) - light olive brown (2.5Y 5/4), damp, medium dense; 70 % fine sand, 30% silt.	
5	1.9	14	MW3-6			SC	CLAYEY SAND (SC) - brown (10YR 5/3), moist, medium dense; 55% fine sand, 45% clay.	
10	19	18	MW3-11			SM	SILTY SAND (SM) - yellowish brown (10YR 5/4), moist, medium dense; 80% fine to medium sand, 20% silt.	
15	91	26	MW3-16			SP	SAND (SP) - light olive brown (2.5Y 5/4); moist, dense; 95% fine to medium sand, 5% silt.	
20	98	47	MW3-21				Color changes to yellowish brown (10YR 5/8) mottled grayish olive (2.5 Y 5/2) at 20 feet.	
25	0	67	MW3-26				∇∇ Becomes very dense and saturated at 25 feet.	
30	0	14	MW3-31			CL	CLAY (CL) - grayish brown (2.5Y 5/2), moist, stiff, low plasticity; 90% clay, 10% fine sand.	
35							(* = converted to equivalent standard penetration blows/ft.)	

Gettler-Ryan Inc.

Log of Boring MW-4

PROJECT: Chevron Service Station No. 9-4800

LOCATION: 1700 Castro Street, Oakland, CA

PROJECT NO.: 346383.03

CASING ELEVATION:

DATE STARTED: 03/23/99

WL (ft. bgs): 24.8 DATE: 03/23/99 TIME: 11:10 am

DATE FINISHED: 03/23/99

WL (ft. bgs): 24.8 DATE: 03/23/99 TIME: 12:15 pm

DRILLING METHOD: 8-inch hollow-stem auger

TOTAL DEPTH: 30 Feet

DRILLING COMPANY: Bay Area Exploration, Inc.

GEOLOGIST: B. Sieminski

DEPTH feet	PID (ppm)	BLOWS/FT. *	SAMPLE NUMBER	SAMPLE INT. GRAPHIC LOG	SOIL CLASS	GEOLOGIC DESCRIPTION	WELL DIAGRAM
						Planting soil.	
					SM	SILTY SAND (SM) - yellowish brown (10YR 5/4) mottled with gray (10YR 5/1), moist, medium dense, 60% fine sand, 40% silt.	
5	1.8	20	MW-4-8		CL SC	SANDY CLAY (CL) - yellowish brown (10YR 5/4), moist, low plasticity, stiff, 70% clay, 30% fine sand. CLAYEY SAND (SC) - yellowish brown (10YR 5/6), moist, medium dense, 70% fine sand, 30% clay.	
10	0	15	MW-4-10			Color change to dark yellowish brown (10YR 4/4) at 10 feet.	
15	7.0	40	MW-4-16		SP	SAND (SP) - light olive brown (2.5Y 5/6), moist, dense, 85% fine sand, 15% silt. Color change to olive (5Y 5/4) at 16 feet.	
20	1.2	48	MW-4-21			Becomes very dense, 80% fine sand, 20% silt.	
	1.0	55	MW-4-23				
25						▽▽ Becomes saturated at 24.8 feet.	
30	0	15	MW-4-29		CL	CLAY (CL) - grayish brown (2.5Y 5/2), moist, stiff, medium plasticity, 100% clay.	
						* Converted to standard penetration blows/foot.	

Gettler-Ryan Inc.

Log of Boring MW-5

PROJECT: Chevron Service Station No. 9-4800

LOCATION: 1700 Castro Street, Oakland, CA

PROJECT NO.: 346383.03

CASING ELEVATION:

DATE STARTED: 03/23/99

WL (ft. bgs): 26.0 DATE: 03/23/99 TIME: 2:00 pm

DATE FINISHED: 03/23/99

WL (ft. bgs): 26.0 DATE: 03/23/99 TIME: 3:15 pm

DRILLING METHOD: 8-inch hollow-stem auger

TOTAL DEPTH: 30 Feet

DRILLING COMPANY: Bay Area Exploration, Inc.

GEOLOGIST: B. Sieminski

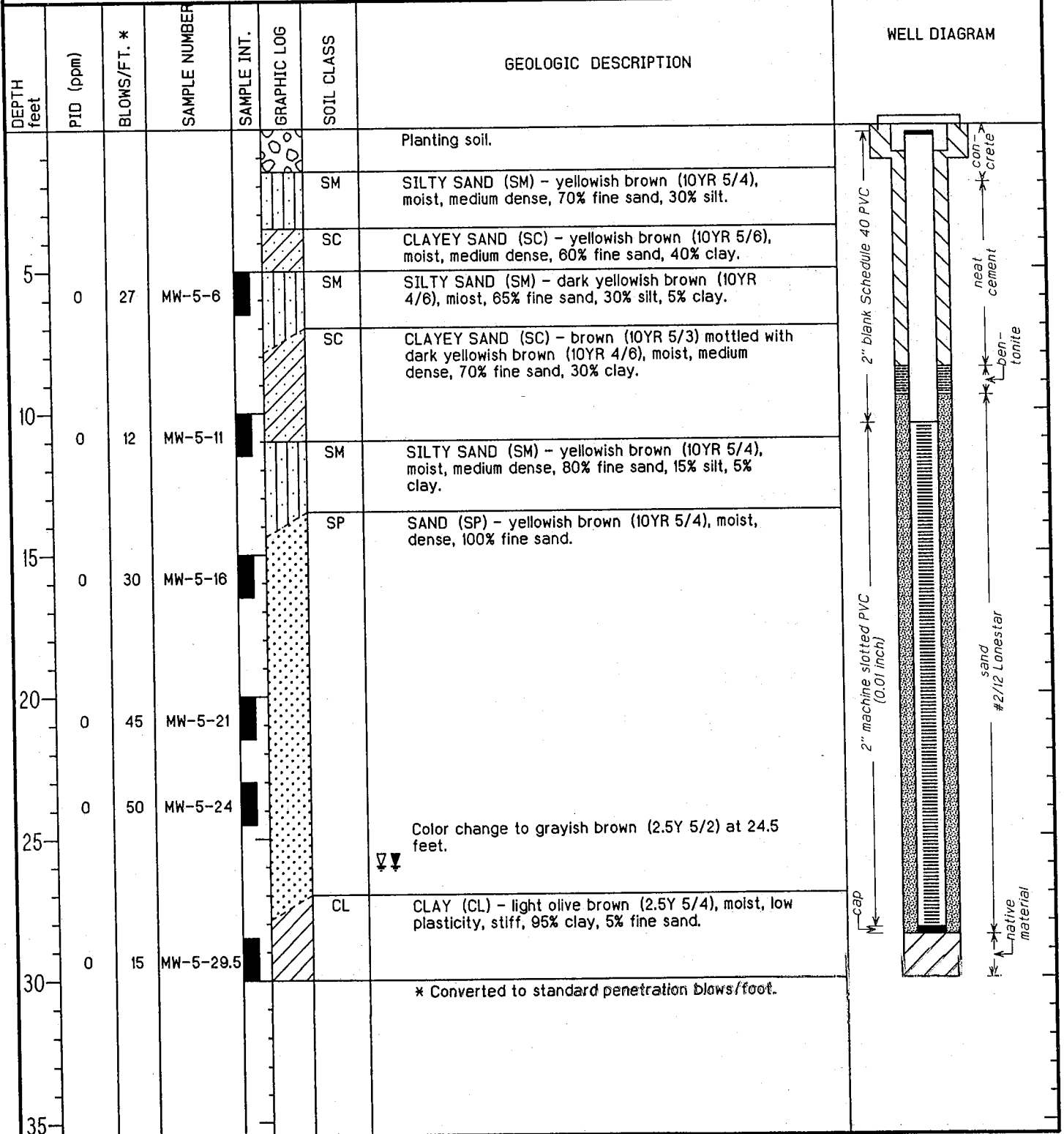

Gettler-Ryan Inc.

Log of Boring MW-6

PROJECT: Chevron Service Station No. 9-4800

LOCATION: 1700 Castro Street, Oakland, CA

PROJECT NO.: 346383.03

CASING ELEVATION:

DATE STARTED: 03/23/99

WL (ft. bgs): 24.0 DATE: 03/23/99 TIME: 4:00 pm

DATE FINISHED: 03/23/99

WL (ft. bgs): 24.0 DATE: 03/23/99 TIME: 5:00 pm

DRILLING METHOD: 8-inch hollow-stem auger

TOTAL DEPTH: 30 Feet

DRILLING COMPANY: Bay Area Exploration, Inc.

GEOLOGIST: B. Sieminski

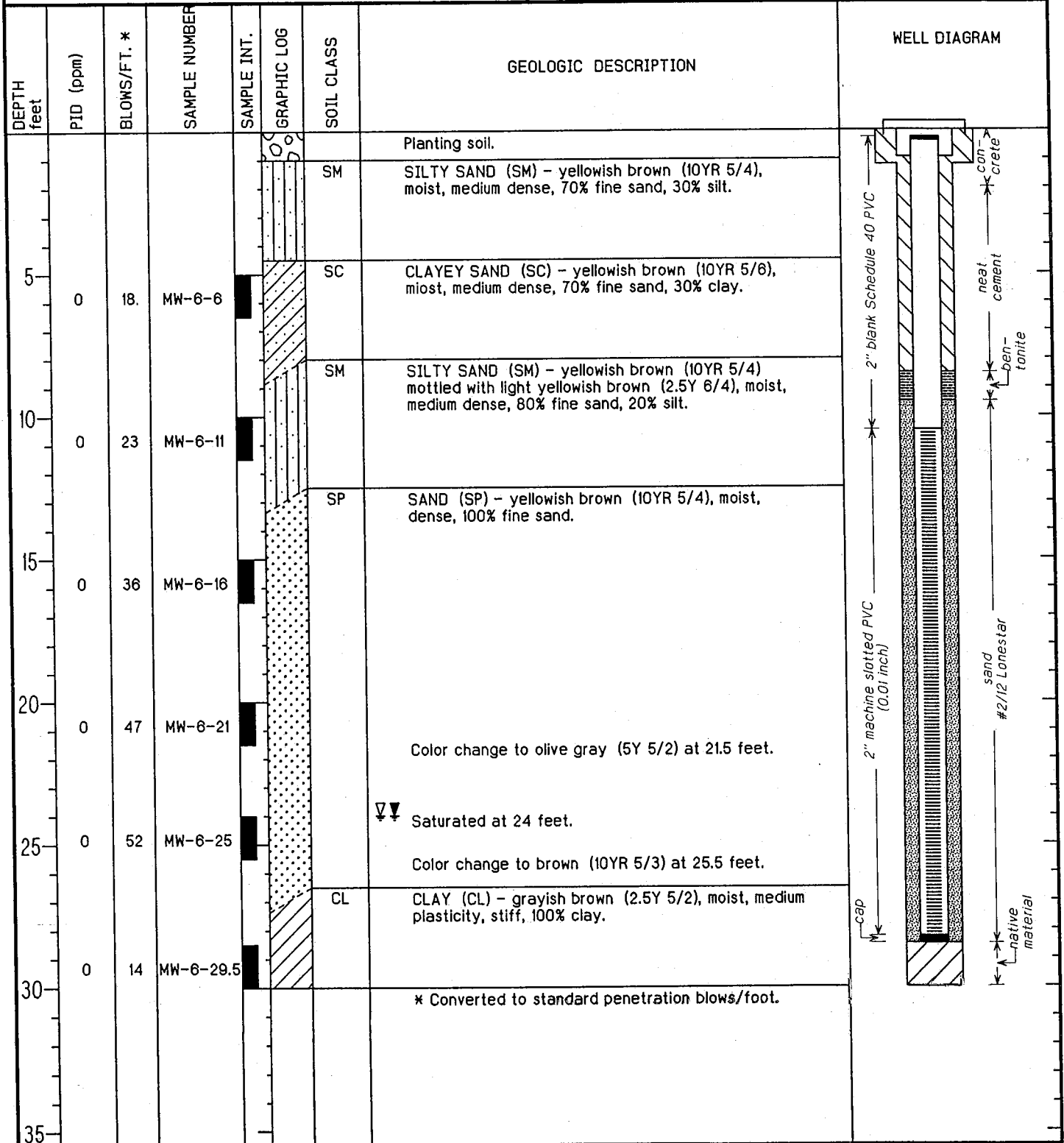

Gettler-Ryan, Inc.

Log of Boring MW-7

PROJECT: *Chevron Service Station No. 9-4800*

LOCATION: *1700 Castro Street, Oakland, CA.*

GR PROJECT NO.: *346383.06*

CASING ELEVATION:

DATE STARTED: *03/30/01*

WL (ft. bgs): *27.6* DATE: *03/30/01* TIME: *10:30*

DATE FINISHED: *03/30/01*

WL (ft. bgs): DATE: TIME:

DRILLING METHOD: *8 in. Hollow Stem Auger*

TOTAL DEPTH: *30 feet*

DRILLING COMPANY: *Gregg Drilling*

GEOLOGIST: *Tony Mikacich*

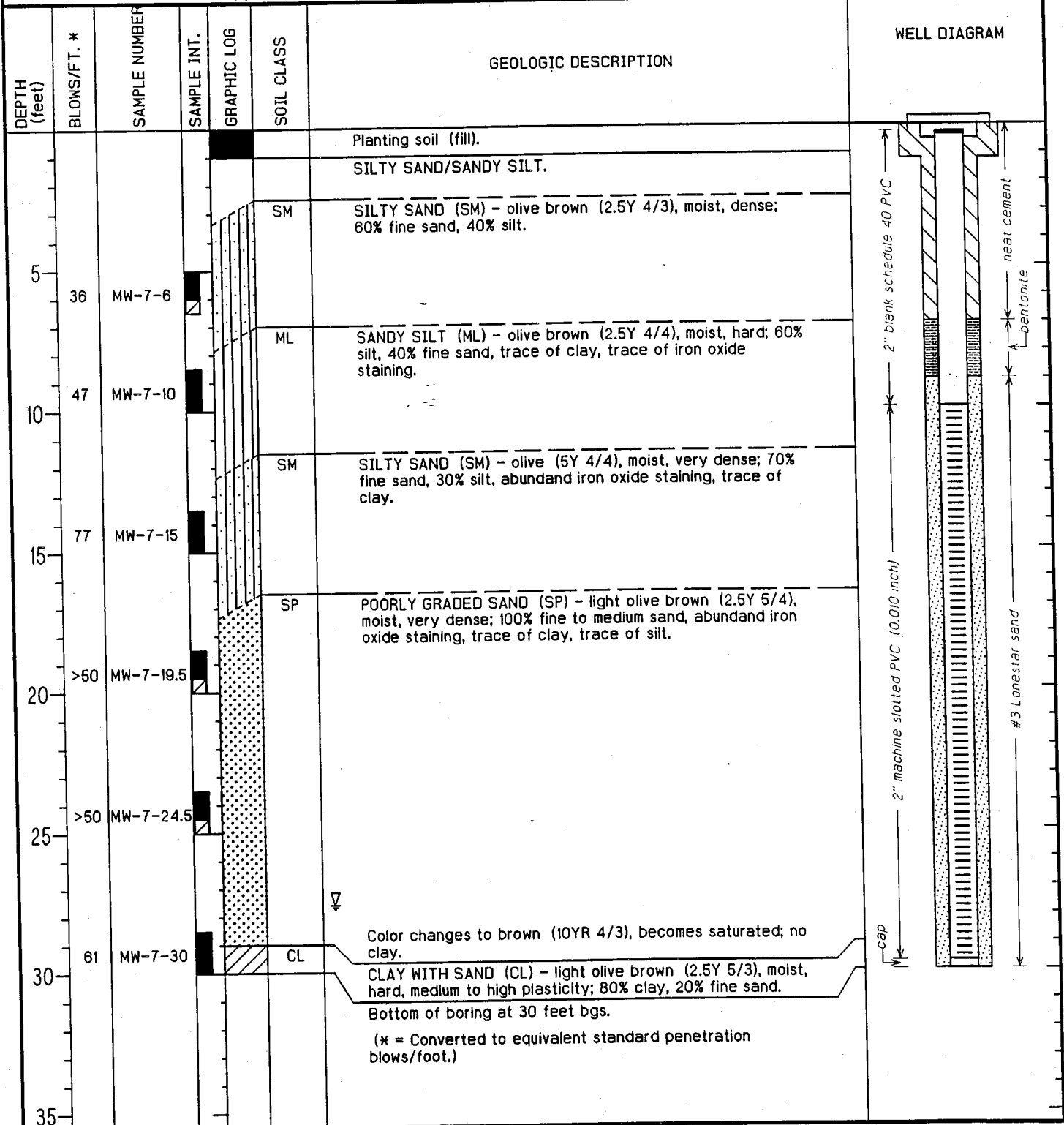

APPENDIX C

GROUNDWATER MONITORING AND SAMPLING DATA

TABLE 1

GROUNDWATER MONITORING AND SAMPLING DATA
 CHEVRON SERVICE STATION 94800
 1700 CASTRO ST.
 OAKLAND, CALIFORNIA

Location	Date	TOC	DTW	GWE	HYDROCARBONS			PRIMARY VOCS						ADDITIONAL VOCS						
					TPH-DRO	TPH-DRO w/ Si Ge	TPH-GRO	B	T	E	X	MTBE by VOC	MTBE by SW8240	MTBE by SW8260	ETHANOL	TBA	DIPE	ETBE	TAME	
	Units	ft	ft	ft-amsl	µg/L	µg/L	µg/L	µg/L	µg/L	µg/L	µg/L	µg/L	µg/L	µg/L	µg/L	µg/L	µg/L	µg/L	µg/L	µg/L
MW-1	06/04/1997	30.75	25.82	4.39	71 ¹	-	890	100	110	29	150	<10	-	-	-	-	-	-	-	-
MW-1	09/16/1997	30.75	25.90	4.85	75 ¹	-	1,600	210	210	60	250	<10	-	-	-	-	-	-	-	-
MW-1	12/17/1997	30.75	25.87	4.88	65 ¹	-	940	120	100	41	160	<25	-	-	-	-	-	-	-	-
MW-1	03/18/1998	30.75	24.85	5.90	77 ¹	-	530	91	39	22	65	6.8	-	-	-	-	-	-	-	-
MW-1	06/28/1998	30.75	24.83	5.92	140 ¹	-	1,100	220	140	37	120	-	14	-	-	-	-	-	-	-
MW-1	09/07/1998	30.75	25.19	5.56	280 ¹	-	1,700	530	86	84	240	49	-	-	-	-	-	-	-	-
MW-1	12/09/1998	30.75	25.65	5.10	240 ¹	-	1,700	240	130	100	270	32	-	-	-	-	-	-	-	-
MW-1	03/11/1999	30.75	25.45	5.30	98 ¹	-	353	53.9	28.6	20.5	56.1	14.1	-	-	-	-	-	-	-	-
MW-1	06/17/1999	30.75	25.36	5.39	217 ¹	-	810	270	150	95	340	15	-	-	-	-	-	-	-	-
MW-1	09/29/1999	30.75	25.62	5.13	153 ¹	-	659	76	49.7	35.1	118	12.6	-	-	-	-	-	-	-	-
MW-1	12/14/1999	30.75	25.68	5.07	188 ^{1,2}	-	2,760	287	199	139	502	<12.5	-	-	-	-	-	-	-	-
MW-1	03/09/2000 ³	30.75	25.21	5.54	166 ¹	-	1,590	238	94.9	72.2	247	22.3	-	-	-	-	-	-	-	-
MW-1	06/10/2000	30.75	25.02	5.73	-	-	1,460	242	47.8	83.8	151	97.3	-	-	-	-	-	-	-	-
MW-1	09/30/2000	30.75	25.45	5.30	240 ⁷	-	650 ⁶	130	49	69	190	21	-	-	-	-	-	-	-	-
MW-1	12/22/2000	30.75	25.70	5.05	200 ⁹	-	640 ⁶	110	33	58	160	68	-	-	-	-	-	-	-	-
MW-1	03/01/2001	30.75	25.50	5.25	211 ⁷	-	1,500 ⁶	210	67.9	109	320	87.3	-	-	-	-	-	-	-	-
MW-1	05/04/2001	30.75	25.34	5.41	130 ⁷	-	991	127	32.6	73.0	137	95.4	-	-	-	-	-	-	-	-
MW-1	09/05/2001	30.75	25.59	5.16	-	-	-	-	-	-	-	-	-	-	-	-	-	-	-	-
MW-1	12/21/2001	30.75	25.58	5.17	210	-	2,000	220	16	110	400	34	-	-	-	-	-	-	-	-
MW-1	03/15/2002	30.75	25.15	5.60	-	-	-	-	-	-	-	-	-	-	-	-	-	-	-	-
MW-1	06/15/2002	30.75	25.26	5.49	140	-	350	54	0.61	12	40	130	-	-	-	-	-	-	-	-
MW-1	09/06/2002	30.75	25.49	5.26	-	-	-	-	-	-	-	-	-	-	-	-	-	-	-	-
MW-1	12/06/2002	30.75	25.63	5.12	2,900	-	900	71	2.1	39	150	34	-	-	-	-	-	-	-	-
MW-1	03/03/2003	30.75	25.29	5.46	-	-	-	-	-	-	-	-	-	-	-	-	-	-	-	-

TABLE 1

**GROUNDWATER MONITORING AND SAMPLING DATA
CHEVRON SERVICE STATION 94800
1700 CASTRO ST.
OAKLAND, CALIFORNIA**

Location	Date	TOC	DTW	GWE	HYDROCARBONS			PRIMARY VOCS						ADDITIONAL VOCS						
					TPH-DRO	TPH-DRO w/ Si Ge	TPH-GRO	B	T	E	X	MTBE by VOC	MTBE by SW8240	MTBE by SW8260	ETHANOL	TBA	DIPE	ETBE	TAME	
	Units	ft	ft	ft-amsl	µg/L	µg/L	µg/L	µg/L	µg/L	µg/L	µg/L	µg/L	µg/L	µg/L	µg/L	µg/L	µg/L	µg/L	µg/L	µg/L
MW-1	06/17/2003 ¹⁴	30.75	25.11	5.64	180	-	290	34	0.6	23	90	-	-	92	-	-	-	-	-	-
MW-1	09/16/2003	30.75	25.38	5.37	-	-	-	-	-	-	-	-	-	-	-	-	-	-	-	-
MW-1	12/31/2003 ¹⁴	30.75	25.55	5.20	150	-	1,500	97	6	70	230	-	-	86	<50	-	-	-	-	-
MW-1	03/26/2004	30.75	25.01	5.74	-	-	-	-	-	-	-	-	-	-	-	-	-	-	-	-
MW-1	08/17/2004 ¹⁴	30.75	26.16	4.59	860	-	500	44	5	12	54	-	-	76	<50	-	-	-	-	-
MW-1	11/16/2004 ¹⁴	34.01	26.16	7.85	<26	-	570	33	<0.5	14	53	-	-	48	<50	-	-	-	-	-
MW-1	02/18/2005	34.01	25.76	8.25	-	-	-	-	-	-	-	-	-	-	-	-	-	-	-	-
MW-1	05/06/2005 ¹⁴	34.01	25.39	8.62	110	-	170	13	<0.5	4	18	-	-	220	<50	-	-	-	-	-
MW-1	08/05/2005	34.01	25.70	8.31	-	-	-	-	-	-	-	-	-	-	-	-	-	-	-	-
MW-1	11/07/2005 ¹⁴	34.01	26.02	7.99	260 ²⁰	-	180	7	<0.5	3	24	-	-	260	<50	-	-	-	-	-
MW-1	02/06/2006	34.01	25.68	8.33	-	-	-	-	-	-	-	-	-	-	-	-	-	-	-	-
MW-1	05/08/2006 ¹⁴	34.01	24.98	9.03	730	-	270	23	<0.7	1	18	590	-	-	<50	-	-	-	-	-
MW-1	08/08/2006	34.01	25.52	8.49	-	-	-	-	-	-	-	-	-	-	-	-	-	-	-	-
MW-1	11/08/2006 ¹⁴	34.01	25.90	8.11	380	-	<50	0.6	<0.5	<0.5	2	140	-	-	<50	-	-	-	-	-
MW-1	02/06/2007	34.01	25.98	8.03	-	-	-	-	-	-	-	-	-	-	-	-	-	-	-	-
MW-1	05/01/2007 ¹⁴	34.01	25.78	8.23	750	-	58	0.8	<0.5	<0.5	1	-	-	280	<50	-	-	-	-	-
MW-1	07/31/2007	34.01	26.00	8.01	-	-	-	-	-	-	-	-	-	-	-	-	-	-	-	-
MW-1	11/08/2007 ¹⁴	34.01	26.16	7.85	330	-	<50	<0.5	<0.5	<0.5	0.9	-	-	270	<50	-	-	-	-	-
MW-1	02/04/2008	34.01	25.97	8.04	-	-	-	-	-	-	-	-	-	-	-	-	-	-	-	-
MW-1	05/01/2008 ¹⁴	34.01	25.95	8.06	86	-	<50	<0.5	<0.5	<0.5	<0.5	-	-	470	<50	-	-	-	-	-
MW-1	08/01/2008	34.01	26.04	7.97	-	-	-	-	-	-	-	-	-	-	-	-	-	-	-	-
MW-1	11/13/2008 ¹⁴	34.01	26.13	7.88	<50	-	170	1	<0.5	<0.5	2	-	-	190	<50	-	-	-	-	-
MW-1	02/23/2009	34.01	25.94	8.07	-	-	-	-	-	-	-	-	-	-	-	-	-	-	-	-
MW-1	05/20/2009	34.01	25.63	8.38	88 J	-	<50	0.6 J	<0.5	<0.5	2	-	-	190	<50	-	-	-	-	-

TABLE 1

GROUNDWATER MONITORING AND SAMPLING DATA
 CHEVRON SERVICE STATION 94800
 1700 CASTRO ST.
 OAKLAND, CALIFORNIA

Location	Date	TOC	DTW	GWE	HYDROCARBONS			PRIMARY VOCs						ADDITIONAL VOCs						
					TPH-DRO	TPH-DRO w/ Si Ge	TPH-GRO	B	T	E	X	MTBE by VOC	MTBE by SW8240	MTBE by SW8260	ETHANOL	TBA	DIPE	ETBE	TAME	
	Units	ft	ft	ft-amsl	µg/L	µg/L	µg/L	µg/L	µg/L	µg/L	µg/L	µg/L	µg/L	µg/L	µg/L	µg/L	µg/L	µg/L	µg/L	µg/L
MW-1	08/25/2009	34.01	25.80	8.21	-	-	-	-	-	-	-	-	-	-	-	-	-	-	-	-
MW-1	11/18/2009	34.01	25.93	8.08	150	-	<50	<0.5	<0.5	0.6 J	<0.5	-	-	310	<50	-	-	-	-	-
MW-1	05/18/2010	34.01	25.54	8.47	110	-	<50	<0.5	<0.5	<0.5	<0.5	-	-	230	<50	9	-	-	-	-
MW-1	12/01/2010	34.01	25.92	8.09	52 J	-	<50	<0.5	<0.5	<0.5	<0.5	-	-	230	<50	-	-	-	-	-
MW-1	05/04/2011	34.01	25.26	8.75	-	75 J	<50	<0.5	<0.5	<0.5	<0.5	-	-	180	<50	-	-	-	-	-
MW-1	12/09/2011	34.01	25.79	8.22	67 J	-	61 J	<0.5	<0.5	<0.5	<0.5	-	-	89	<50	-	-	-	-	-
MW-1	05/31/2012	34.01	25.49	8.52	<50	-	<50	<0.5	<0.5	<0.5	<0.5	-	-	23	<50	-	-	-	-	-
MW-1	11/14/2012	34.01	26.00	8.01	-	<50	<50	<0.5	<0.5	<0.5	<0.5	-	-	3	<50	-	-	-	-	-
MW-1	06/03/2013	34.01	25.94	8.07	-	<50	<50	<0.5	<0.5	<0.5	<0.5	-	-	1	<50	-	-	-	-	-
MW-1	12/12/2013	34.01	26.70	7.31	<50	-	<50	<0.5	<0.5	<0.5	<0.5	-	-	<0.5	<50	-	-	-	-	-
MW-2	06/04/1997	30.00	24.87	5.13	4,000 ¹	-	13,000	790	30	420	1,700	4,000	-	-	-	-	-	-	-	-
MW-2	09/16/1997	30.00	24.94	5.06	2,200 ¹	-	4,000	360	9.7	210	460	1,500	-	-	-	-	-	-	-	-
MW-2	12/17/1997	30.00	24.82	5.18	2,100 ¹	-	4,100	380	<10	200	460	2,100	-	-	-	-	-	-	-	-
MW-2	03/18/1998	30.00	23.57	6.43	3,700 ¹	-	8,400	1,800	<50	350	630	13,000	-	-	-	-	-	-	-	-
MW-2	06/28/1998 ⁴	30.00	23.79	6.21	4,400 ¹	-	9,300	740	340	710	2,300	-	3,800	-	-	-	-	-	-	-
MW-2	09/07/1998	30.00	24.22	5.78	3,100 ¹	-	9,900	1,000	150	640	1,800	4,500 / 4,100 ⁵	-	-	-	-	-	-	-	-
MW-2	12/09/1998	30.00	24.69	5.31	1,900 ¹	-	8,500	860	74	610	960	2,600 / 2,600 ⁵	-	-	-	-	-	-	-	-
MW-2	03/11/1999	30.00	24.21	5.79	2,700 ¹	-	12,500	1,520	42.2	645	2,250	5,050 / 3,400 ⁵	-	-	-	-	-	-	-	-
MW-2	06/17/1999	30.00	24.31	5.69	7,150 ¹	-	27,000	2,200	260	1,500	5,900	4,700	-	-	-	-	-	-	-	-
MW-2	09/29/1999	30.00	24.55	5.45	3,030 ¹	-	6,910	582	11.1	491	1,170	1,970	-	-	-	-	-	-	-	-
MW-2	12/14/1999	30.00	24.61	5.39	615 ^{1,2}	-	4,230	282	12.3	284	690	631	-	-	-	-	-	-	-	-
MW-2	03/09/2000 ³	30.00	23.92	6.08	3,300 ¹	-	15,300	1,110	39.4	1,040	3,030	2,470	-	-	-	-	-	-	-	-
MW-2	06/10/2000	30.00	23.87	6.13	-	-	7,360	560	40.7	627	1,280	1,260	-	-	-	-	-	-	-	-

TABLE 1

GROUNDWATER MONITORING AND SAMPLING DATA
 CHEVRON SERVICE STATION 94800
 1700 CASTRO ST.
 OAKLAND, CALIFORNIA

Location	Date	TOC	DTW	GWE	HYDROCARBONS			PRIMARY VOCS						ADDITIONAL VOCS						
					TPH-DRO	TPH-DRO w/ Si Ge	TPH-GRO	B	T	E	X	MTBE by VOC	MTBE by SW8240	MTBE by SW8260	ETHANOL	TBA	DIPE	ETBE	TAME	
	Units	ft	ft	ft-amsl	µg/L	µg/L	µg/L	µg/L	µg/L	µg/L	µg/L	µg/L	µg/L	µg/L	µg/L	µg/L	µg/L	µg/L	µg/L	µg/L
MW-2	09/30/2000	30.00	24.33	5.67	1,800 ⁷	-	3,600 ⁶	280	<10	420	430	290	-	-	-	-	-	-	-	-
MW-2	12/22/2000	30.00	24.61	5.39	870 ⁹	-	1,500 ⁶	100	<1.3	160	59	380	-	-	-	-	-	-	-	-
MW-2	03/01/2001	30.00	24.21	5.79	1,320 ⁷	-	2,340 ⁶	171	<5.00	238	157	864	-	-	-	-	-	-	-	-
MW-2	05/04/2001	30.00	24.17	5.83	3,100 ⁷	-	11,900	199	33.9	1,420	290	3,890	-	-	-	-	-	-	-	-
MW-2	09/05/2001	30.00	24.55	5.45	2,200	-	3,300	170	1.7	310	110	1,100	-	-	-	-	-	-	-	-
MW-2	12/21/2001	30.00	24.40	5.60	980	-	1,100	58	0.72	120	14	450	-	-	-	-	-	-	-	-
MW-2	03/15/2002	30.00	23.95	6.05	2,200	-	5,000	250	9.1	470	430	1,800	-	-	-	-	-	-	-	-
MW-2	06/15/2002	30.00	24.16	5.84	3,700	-	5,200	240	5.2	540	210	2,200	-	-	-	-	-	-	-	-
MW-2	09/06/2002	30.00	24.41	5.59	2,200	-	2,100	84	1.4	250	30	1,000	-	-	-	-	-	-	-	-
MW-2	12/06/2002	30.00	24.56	5.44	730	-	780	21	<0.50	58	3.4	480	-	-	-	-	-	-	-	-
MW-2	03/03/2003	30.00	24.21	5.79	3,500	-	4,800	220	1.9	650	46	4,400	-	-	-	-	-	-	-	-
MW-2	06/17/2003 ¹⁴	30.00	23.93	6.07	4,100	-	4,700	140	4	370	84	-	-	2,700	-	-	-	-	-	-
MW-2	09/16/2003 ¹⁴	30.00	24.31	5.69	1,800 ¹⁵	-	1,300	38	<1	110	3	-	-	1,300	<130	-	-	-	-	-
MW-2	12/31/2003 ¹⁴	30.00	24.36	5.64	330	-	990	11	<0.5	23	3	-	-	440	<50	-	-	-	-	-
MW-2	03/26/2004	30.00	23.75	6.25	-	-	-	-	-	-	-	-	-	-	-	-	-	-	-	-
MW-2	08/17/2004 ¹⁴	30.00	24.47	5.53	400	-	300	9	<0.5	18	1	-	-	340	<50	-	-	-	-	-
MW-2	11/16/2004 ¹⁴	32.59	24.45	8.14	4,300	-	10,000	91	7	830	1,300	-	-	1,100	<100	-	-	-	-	-
MW-2	02/18/2005	32.59	23.92	8.67	-	-	-	-	-	-	-	-	-	-	-	-	-	-	-	-
MW-2	05/06/2005 ¹⁴	32.59	23.53	9.06	1,300	-	4,900	62	4	290	320	-	-	400	<50	-	-	-	-	-
MW-2	08/05/2005	32.59	23.98	8.61	-	-	-	-	-	-	-	-	-	-	-	-	-	-	-	-
MW-2	11/07/2005 ¹⁴	32.59	24.32	8.27	300 ²⁰	-	800	2	<0.5	<0.5	<0.5	-	-	66	<50	-	-	-	-	-
MW-2	02/06/2006	32.59	23.83	8.76	-	-	-	-	-	-	-	-	-	-	-	-	-	-	-	-
MW-2	05/08/2006 ¹⁴	32.59	23.10	9.49	2,100	-	6,100	32	4	430	460	360	-	-	<50	-	-	-	-	-
MW-2	08/08/2006	32.59	23.80	8.79	-	-	-	-	-	-	-	-	-	-	-	-	-	-	-	-

TABLE 1

GROUNDWATER MONITORING AND SAMPLING DATA
 CHEVRON SERVICE STATION 94800
 1700 CASTRO ST.
 OAKLAND, CALIFORNIA

Location	Date	TOC	DTW	GWE	HYDROCARBONS			PRIMARY VOCS						ADDITIONAL VOCS					
					TPH-DRO	TPH-DRO w/ Si Ge	TPH-GRO	B	T	E	X	MTBE by VOC	MTBE by SW8240	MTBE by SW8260	ETHANOL	TBA	DIPE	ETBE	TAME
	Units	ft	ft	ft-amsl	µg/L	µg/L	µg/L	µg/L	µg/L	µg/L	µg/L	µg/L	µg/L	µg/L	µg/L	µg/L	µg/L	µg/L	µg/L
MW-2	11/08/2006 ¹⁴	32.59	24.27	8.32	770	-	120	12	<0.5	0.7	8	840	-	-	<50	-	-	-	-
MW-2	02/06/2007	32.59	24.29	8.30	-	-	-	-	-	-	-	-	-	-	-	-	-	-	-
MW-2	05/01/2007 ¹⁴	32.59	24.05	8.54	160	-	850	<0.5	<0.5	16	36	-	-	100	<50	-	-	-	-
MW-2	07/31/2007	32.59	24.31	8.28	-	-	-	-	-	-	-	-	-	-	-	-	-	-	-
MW-2	11/08/2007 ¹⁴	32.59	24.47	8.12	800	-	180	<0.5	<0.5	<0.5	<0.5	-	-	37	<50	-	-	-	-
MW-2	02/04/2008	32.59	24.21	8.38	-	-	-	-	-	-	-	-	-	-	-	-	-	-	-
MW-2	05/01/2008 ¹⁴	32.59	24.25	8.34	500	-	430	<0.5	<0.5	<0.5	5	-	-	120	<50	-	-	-	-
MW-2	08/01/2008	32.59	24.33	8.26	-	-	-	-	-	-	-	-	-	-	-	-	-	-	-
MW-2	11/13/2008 ¹⁴	32.59	24.42	8.17	2,600	-	2,500	3	1	190	83	-	-	240	<50	-	-	-	-
MW-2	02/23/2009	32.59	24.21	8.38	-	-	-	-	-	-	-	-	-	-	-	-	-	-	-
MW-2	05/20/2009	32.59	23.65	8.94	2,800 J	-	4,000	4	1	42	55	-	-	160	<50	-	-	-	-
MW-2	08/25/2009	32.59	24.00	8.59	-	-	-	-	-	-	-	-	-	-	-	-	-	-	-
MW-2	11/18/2009	32.59	24.51	8.08	2,800	-	5,400	4	1 J	69	34	-	-	79	<100	-	-	-	-
MW-2	05/18/2010	32.59	23.65	8.94	1,100	-	580	<0.5	<0.5	<0.5	<0.5	-	-	22	<50	6	-	-	-
MW-2	12/01/2010	32.59	24.20	8.39	930	-	230	<0.5	<0.5	<0.5	<0.5	-	-	20	<50	-	-	-	-
MW-2	05/04/2011	32.59	23.50	9.09	-	1,300	830	<0.5	<0.5	51	10	-	-	16	<50	-	-	-	-
MW-2	12/09/2011	32.59	24.12	8.47	180	-	140	<0.5	<0.5	<0.5	<0.5	-	-	8	<50	-	-	-	-
MW-2	05/31/2012	32.59	23.94	8.65	78 J	-	75 J	<0.5	<0.5	<0.5	<0.5	-	-	4	<50	-	-	-	-
MW-2	11/14/2012	32.59	24.12	8.47	-	78 J	69 J	<0.5	<0.5	<0.5	<0.5	-	-	3	<50	-	-	-	-
MW-2	06/03/2013	32.59	24.31	8.28	-	<50	<50	<0.5	<0.5	<0.5	<0.5	-	-	2	<50	-	-	-	-
MW-2	12/12/2013	32.59	25.23	7.36	89 J	-	69 J	<0.5	<0.5	<0.5	<0.5	-	-	0.7 J	<50	-	-	-	-
MW-3	06/04/1997	31.32	26.05	5.27	<50	-	190	26	20	1.5	16	8.2	-	-	-	-	-	-	-
MW-3	09/16/1997	31.32	26.15	5.17	<50	-	270	58	53	6.1	30	21	-	-	-	-	-	-	-

TABLE 1

GROUNDWATER MONITORING AND SAMPLING DATA
 CHEVRON SERVICE STATION 94800
 1700 CASTRO ST.
 OAKLAND, CALIFORNIA

Location	Date	TOC	DTW	GWE	HYDROCARBONS			PRIMARY VOCS						ADDITIONAL VOCS						
					TPH-DRO	TPH-DRO w/ Si Ge	TPH-GRO	B	T	E	X	MTBE by VOC	MTBE by SW8240	MTBE by SW8260	ETHANOL	TBA	DIPE	ETBE	TAME	
	Units	ft	ft	ft-amsl	µg/L	µg/L	µg/L	µg/L	µg/L	µg/L	µg/L	µg/L	µg/L	µg/L	µg/L	µg/L	µg/L	µg/L	µg/L	µg/L
MW-3	12/17/1997	31.32	26.10	5.22	<50	-	290	50	54	8.1	37	21	-	-	-	-	-	-	-	-
MW-3	03/18/1998	31.32	24.90	6.42	<50	-	390	140	33	4.6	30	94	-	-	-	-	-	-	-	-
MW-3	06/28/1998	31.32	24.93	6.39	<50	-	290	90	11	1.6	13	-	150	-	-	-	-	-	-	-
MW-3	09/07/1998	31.32	25.35	5.97	<50	-	170	46	20	4.3	19	120	-	-	-	-	-	-	-	-
MW-3	12/09/1998	31.32	25.91	5.41	55 ¹	-	660	120	93	22	72	150	-	-	-	-	-	-	-	-
MW-3	03/11/1999	31.32	25.47	5.85	<50	-	653	136	69.5	13.7	63.8	144	-	-	-	-	-	-	-	-
MW-3	06/17/1999	31.32	25.42	5.90	103 ¹	-	530	190	110	24	88	210	-	-	-	-	-	-	-	-
MW-3	09/29/1999	31.32	25.71	5.61	232 ¹	-	433	97.8	61.4	16.9	56.6	156	-	-	-	-	-	-	-	-
MW-3	12/14/1999	31.32	25.77	5.55	<50 ²	-	8,650	1,040	795	212	800	995	-	-	-	-	-	-	-	-
MW-3	03/09/2000 ³	31.32	25.18	6.14	74.6 ¹	-	1,170	304	103	25.2	114	539	-	-	-	-	-	-	-	-
MW-3	06/10/2000	31.32	25.03	6.29	-	-	359	63.8	27.8	10.5	35.4	393	-	-	-	-	-	-	-	-
MW-3	09/30/2000	31.32	25.53	5.79	100 ⁸	-	220 ⁶	42	33	12	38	67	-	-	-	-	-	-	-	-
MW-3	12/22/2000	31.32	25.80	5.52	110 ⁹	-	370 ⁶	96	48	18	58	180	-	-	-	-	-	-	-	-
MW-3	03/01/2001	31.32	25.57	5.75	144 ⁷	-	912 ⁶	218	89.0	36.0	110	310	-	-	-	-	-	-	-	-
MW-3	05/04/2001	31.32	25.36	5.96	<50	-	1,260	146	79.6	38.2	101	1,070	-	-	-	-	-	-	-	-
MW-3	09/05/2001	31.32	25.71	5.61	-	-	-	-	-	-	-	-	-	-	-	-	-	-	-	-
MW-3	12/21/2001	31.32	25.65	5.67	180	-	850	160	11	32	84	300	-	-	-	-	-	-	-	-
MW-3	03/15/2002	31.32	25.17	6.15	-	-	-	-	-	-	-	-	-	-	-	-	-	-	-	-
MW-3	06/15/2002	31.32	25.31	6.01	<50	-	550	110	3.0	23	58	590	-	-	-	-	-	-	-	-
MW-3	09/06/2002	31.32	25.58	5.74	-	-	-	-	-	-	-	-	-	-	-	-	-	-	-	-
MW-3	12/06/2002	31.32	25.76	5.56	160	-	350	60	1.3	11	32	530	-	-	-	-	-	-	-	-
MW-3	03/03/2003	31.32	25.40	5.92	-	-	-	-	-	-	-	-	-	-	-	-	-	-	-	-
MW-3	06/17/2003 ¹⁴	31.32	25.13	6.19	130	-	560	90	2	19	57	-	-	590	-	-	-	-	-	-
MW-3	09/16/2003	31.32	25.47	5.85	-	-	-	-	-	-	-	-	-	-	-	-	-	-	-	-

TABLE 1

GROUNDWATER MONITORING AND SAMPLING DATA
 CHEVRON SERVICE STATION 94800
 1700 CASTRO ST.
 OAKLAND, CALIFORNIA

Location	Date	TOC	DTW	GWE	HYDROCARBONS			PRIMARY VOCS						ADDITIONAL VOCS						
					TPH-DRO	TPH-DRO w/ Si Ge	TPH-GRO	B	T	E	X	MTBE by VOC	MTBE by SW8240	MTBE by SW8260	ETHANOL	TBA	DIPE	ETBE	TAME	
	Units	ft	ft	ft-amsl	µg/L	µg/L	µg/L	µg/L	µg/L	µg/L	µg/L	µg/L	µg/L	µg/L	µg/L	µg/L	µg/L	µg/L	µg/L	µg/L
MW-3	12/31/2003 ¹⁴	31.32	25.65	5.67	120	-	840	140	24	25	87	-	-	670	66	-	-	-	-	-
MW-3	03/26/2004	31.32	24.99	6.33	-	-	-	-	-	-	-	-	-	-	-	-	-	-	-	-
MW-3	08/17/2004 ¹⁴	31.32	25.86	5.46	110	-	630	84	18	11	35	-	-	410	<50	-	-	-	-	-
MW-3	11/16/2004 ¹⁴	34.16	25.90	8.26	92	-	740	100	4	21	45	-	-	460	<50	-	-	-	-	-
MW-3	02/18/2005	34.16	25.37	8.79	-	-	-	-	-	-	-	-	-	-	-	-	-	-	-	-
MW-3	05/06/2005 ¹⁴	34.16	24.98	9.18	83	-	290	43	<1	6	11	-	-	740	<100	-	-	-	-	-
MW-3	08/05/2005	34.16	25.35	8.81	-	-	-	-	-	-	-	-	-	-	-	-	-	-	-	-
MW-3	11/07/2005 ¹⁴	34.16	25.69	8.47	66	-	220	29	0.7	3	26	-	-	440	<50	-	-	-	-	-
MW-3	02/06/2006	34.16	25.28	8.88	-	-	-	-	-	-	-	-	-	-	-	-	-	-	-	-
MW-3	05/08/2006 ¹⁴	34.16	24.49	9.67	310	-	560	70	<1	3	24	3,300	-	-	<100	-	-	-	-	-
MW-3	08/08/2006	34.16	25.16	9.00	-	-	-	-	-	-	-	-	-	-	-	-	-	-	-	-
MW-3	11/08/2006 ¹⁴	34.16	25.59	8.57	210	-	510	<0.5	<0.5	<0.5	<0.5	73	-	-	<50	-	-	-	-	-
MW-3	02/06/2007	34.16	25.68	8.48	-	-	-	-	-	-	-	-	-	-	-	-	-	-	-	-
MW-3	05/01/2007 ¹⁴	34.16	25.46	8.70	84	-	260	36	<0.5	0.8	18	-	-	1,200	<50	-	-	-	-	-
MW-3	07/31/2007	34.16	25.70	8.46	-	-	-	-	-	-	-	-	-	-	-	-	-	-	-	-
MW-3	11/08/2007 ¹⁴	34.16	25.87	8.29	260	-	270	32	0.9	3	29	-	-	440	<50	-	-	-	-	-
MW-3	02/04/2008	34.16	25.68	8.48	-	-	-	-	-	-	-	-	-	-	-	-	-	-	-	-
MW-3	05/01/2008 ¹⁴	34.16	25.66	8.50	82	-	240	30	<0.5	<0.5	20	-	-	690	<50	-	-	-	-	-
MW-3	08/01/2008	34.16	25.76	8.40	-	-	-	-	-	-	-	-	-	-	-	-	-	-	-	-
MW-3	11/13/2008 ¹⁴	34.16	25.80	8.36	<50	-	720	22	<0.5	<0.5	7	-	-	790	<50	-	-	-	-	-
MW-3	02/23/2009	34.16	25.72	8.44	-	-	-	-	-	-	-	-	-	-	-	-	-	-	-	-
MW-3	05/20/2009	34.16	25.30	8.86	210	-	460	42	<0.5	1	20	-	-	450	<50	-	-	-	-	-
MW-3	08/25/2009	34.16	25.56	8.60	-	-	-	-	-	-	-	-	-	-	-	-	-	-	-	-
MW-3	11/18/2009	34.16	25.71	8.45	240	-	280	25	<0.5	<0.5	9	-	-	170	<50	-	-	-	-	-

TABLE 1

GROUNDWATER MONITORING AND SAMPLING DATA
 CHEVRON SERVICE STATION 94800
 1700 CASTRO ST.
 OAKLAND, CALIFORNIA

Location	Date	TOC	DTW	GWE	HYDROCARBONS			PRIMARY VOCS						ADDITIONAL VOCS						
					TPH-DRO	TPH-DRO w/ Si Ge	TPH-GRO	B	T	E	X	MTBE by VOC	MTBE by SW8240	MTBE by SW8260	ETHANOL	TBA	DIPE	ETBE	TAME	
	Units	ft	ft	ft-amsl	µg/L	µg/L	µg/L	µg/L	µg/L	µg/L	µg/L	µg/L	µg/L	µg/L	µg/L	µg/L	µg/L	µg/L	µg/L	µg/L
MW-3	05/18/2010	34.16	25.11	9.05	150	-	63 J	11	<0.5	<0.5	1	-	-	110	<50	470	-	-	-	-
MW-3	12/01/2010	34.16	25.69	8.47	110	-	78 J	6	<0.5	<0.5	3	-	-	19	<50	-	-	-	-	
MW-3	05/04/2011	34.16	24.90	9.26	-	250	370	30	<0.5	<0.5	8	-	-	200	<50	-	-	-	-	
MW-3	12/09/2011	34.16	25.56	8.60	64 J	-	210	10	<0.5	<0.5	9	-	-	230	<50	-	-	-	-	
MW-3	05/31/2012	34.16	25.13	9.03	<50	-	<50	1	<0.5	<0.5	1	-	-	18	<50	-	-	-	-	
MW-3	11/14/2012	34.16	25.36	8.80	-	<50	56 J	2	<0.5	<0.5	4	-	-	150	<50	-	-	-	-	
MW-3	06/03/2013	34.16	25.72	8.44	-	110	73 J	2	<0.5	<0.5	3	-	-	42	<50	-	-	-	-	
MW-3	12/12/2013	34.16	26.47	7.69	140	-	110	1	<0.5	<0.5	2	-	-	74	<50	-	-	-	-	
MW-4	04/08/1999	30.13	-	-	-	-	130	3.1	<0.5	<0.5	7.7	4,700 / 5,400	-	-	<25,000	<5,000	<100	<100	<100	
MW-4	06/17/1999	30.13	24.94	5.19	3,780 ¹	-	590	58	<5.0	<5.0	160	6,200	-	-	-	-	-	-	-	
MW-4	09/29/1999	30.13	25.17	4.96	1,130 ¹	-	692	10.7	<2.5	5.51	236	7,840	-	-	-	-	-	-	-	
MW-4	12/14/1999	30.13	25.22	4.91	571 ^{1,2}	-	625	<10	3.83	<10	94.6	4,470	-	-	-	-	-	-	-	
MW-4	03/09/2000 ³	30.13	24.68	5.45	600 ¹	-	402	3.76	1.18	<0.5	71.4	3,140	-	-	-	-	-	-	-	
MW-4	06/10/2000	30.13	24.60	5.53	-	-	<1,000	13.2	<10.0	<10.0	97.8	3,080	-	-	-	-	-	-	-	
MW-4	09/30/2000	30.13	25.04	5.09	1,400 ⁷	-	280 ⁶	21	0.67	6.3	60	3,300	-	-	-	-	-	-	-	
MW-4	12/22/2000	30.13	25.23	4.90	740 ⁹	-	240 ⁶	2.2	<0.50	1.3	25	2,200	-	-	-	-	-	-	-	
MW-4	03/01/2001	30.13	24.98	5.15	661 ⁷	-	193	2.31	<0.500	1.34	12.1	1,220	-	-	-	-	-	-	-	
MW-4	05/04/2001	30.13	24.88	5.25	1,100 ⁷	-	722	12.0	<5.00	17.1	89.4	2,390	-	-	-	-	-	-	-	
MW-4	09/05/2001	30.13	25.17	4.96	2,500	-	1,400	23	2.2	19	260	2,300	-	-	-	-	-	-	-	
MW-4	12/21/2001	30.13	25.07	5.06	1,100	-	310	2.9	<0.50	2.6	32	860	-	-	-	-	-	-	-	
MW-4	03/15/2002	30.13	24.69	5.44	3,100	-	520	5.0	<0.50	15	6.8	2,700	-	-	-	-	-	-	-	
MW-4	06/15/2002	30.13	24.84	5.29	2,400	-	950	16	3.6	41	100	2,200	-	2,400 ¹²	-	840	<2.0	<2.0	110	
MW-4	09/06/2002	30.13	25.06	5.07	2,600	-	640	9.6	0.52	9.8	28	1,700	-	-	-	-	-	-	-	

TABLE 1

GROUNDWATER MONITORING AND SAMPLING DATA
 CHEVRON SERVICE STATION 94800
 1700 CASTRO ST.
 OAKLAND, CALIFORNIA

Location	Date	TOC	DTW	GWE	HYDROCARBONS			PRIMARY VOCS						ADDITIONAL VOCS						
					TPH-DRO	TPH-DRO w/ Si Ge	TPH-GRO	B	T	E	X	MTBE by VOC	MTBE by SW8240	MTBE by SW8260	ETHANOL	TBA	DIPE	ETBE	TAME	
	Units	ft	ft	ft-amsl	µg/L	µg/L	µg/L	µg/L	µg/L	µg/L	µg/L	µg/L	µg/L	µg/L	µg/L	µg/L	µg/L	µg/L	µg/L	µg/L
MW-4	12/06/2002	30.13	25.20	4.93	1,400	-	280	3.6	<0.50	1.7	<1.5	730	-	-	-	-	-	-	-	-
MW-4	03/03/2003	30.13	24.85	5.28	1,500	-	280	2.7	<0.50	7.3	2.3	910	-	-	-	-	-	-	-	-
MW-4	06/17/2003 ¹⁴	30.13	24.69	5.44	2,000	-	660	8	1	38	16	-	-	1,100	-	520	<0.5	<0.5	110	
MW-4	09/16/2003 ¹⁴	30.13	24.98	5.15	2,100 ¹⁶	-	480	6	<1	11	3	-	-	710	<100	-	-	-	-	-
MW-4	12/31/2003 ¹⁴	30.13	25.06	5.07	1,400	-	220	3	<0.5	2	<0.5	-	-	390	<50	-	-	-	-	-
MW-4	03/26/2004	30.13	24.53	5.60	-	-	-	-	-	-	-	-	-	-	-	-	-	-	-	-
MW-4	08/17/2004 ¹⁴	30.13	25.45	4.68	2,100	-	470	12	1	28	4	-	-	370	<50	66	<0.5	<0.5	50	
MW-4	11/16/2004 ¹⁴	33.07	25.44	7.63	960	-	270	7	<0.5	7	6	-	-	270	<50	-	-	-	-	-
MW-4	02/18/2005	33.07	25.00	8.07	-	-	-	-	-	-	-	-	-	-	-	-	-	-	-	-
MW-4	05/06/2005 ¹⁴	33.07	24.69	8.38	350	-	86	0.7	<0.5	<0.5	<0.5	-	-	110	<50	21	<0.5	<0.5	8	
MW-4	08/05/2005	33.07	25.02	8.05	-	-	-	-	-	-	-	-	-	-	-	-	-	-	-	-
MW-4	11/07/2005 ¹⁴	33.07	25.33	7.74	150	-	54	0.6	<0.5	<0.5	<0.5	-	-	59	<50	-	-	-	-	-
MW-4	02/06/2006	33.07	24.94	8.13	-	-	-	-	-	-	-	-	-	-	-	-	-	-	-	-
MW-4	05/08/2006 ¹⁴	33.07	24.27	8.80	200	-	66	0.5	<0.5	<0.5	<0.5	92	-	-	<50	-	-	-	-	-
MW-4	08/08/2006	33.07	25.16	7.91	-	-	-	-	-	-	-	-	-	-	-	-	-	-	-	-
MW-4	11/08/2006 ¹⁴	33.07	25.23	7.84	400	-	55	<0.5	<0.5	<0.5	<0.5	40	-	-	<50	-	-	-	-	-
MW-4	02/06/2007	33.07	25.28	7.79	-	-	-	-	-	-	-	-	-	-	-	-	-	-	-	-
MW-4	05/01/2007 ¹⁴	33.07	25.08	7.99	150	-	67	<0.5	<0.5	<0.5	<0.5	-	-	76	<50	10	<0.5	<0.5	6	
MW-4	07/31/2007	33.07	25.27	7.80	-	-	-	-	-	-	-	-	-	-	-	-	-	-	-	-
MW-4	11/08/2007 ¹⁴	33.07	25.42	7.65	850	-	<50	<0.5	<0.5	<0.5	<0.5	-	-	44	<50	-	-	-	-	-
MW-4	02/04/2008	33.07	25.23	7.84	-	-	-	-	-	-	-	-	-	-	-	-	-	-	-	-
MW-4	05/01/2008 ¹⁴	33.07	25.21	7.86	110	-	<50	<0.5	<0.5	<0.5	<0.5	-	-	67	<50	12	<0.5	<0.5	4	
MW-4	08/01/2008	33.07	25.28	7.79	-	-	-	-	-	-	-	-	-	-	-	-	-	-	-	-
MW-4	11/13/2008 ¹⁴	33.07	25.43	7.64	330	-	64	<0.5	<0.5	<0.5	1	-	-	220	<50	-	-	-	-	-

**GROUNDWATER MONITORING AND SAMPLING DATA
CHEVRON SERVICE STATION 94800
1700 CASTRO ST.
OAKLAND, CALIFORNIA**

Location	Date	TOC	DTW	GWE	HYDROCARBONS			PRIMARY VOCS						ADDITIONAL VOCS						
					TPH-DRO	TPH-DRO w/ Si Ge	TPH-GRO	B	T	E	X	MTBE by VOC	MTBE by SW8240	MTBE by SW8260	ETHANOL	TBA	DIPE	ETBE	TAME	
	Units	ft	ft	ft-amsl	µg/L	µg/L	µg/L	µg/L	µg/L	µg/L	µg/L	µg/L	µg/L	µg/L	µg/L	µg/L	µg/L	µg/L	µg/L	µg/L
MW-4	02/23/2009	33.07	25.06	8.01	-	-	-	-	-	-	-	-	-	-	-	-	-	-	-	-
MW-4	05/20/2009	33.07	24.73	8.34	560	-	130	<0.5	<0.5	<0.5	<0.5	-	-	190	<50	58	<0.5	<0.5	6	
MW-4	08/25/2009	33.07	24.97	8.10	-	-	-	-	-	-	-	-	-	-	-	-	-	-	-	
MW-4	11/18/2009	33.07	25.27	7.80	860	-	120	<0.5	<0.5	<0.5	<0.5	-	-	150	<50	-	-	-	-	
MW-4	05/18/2010	33.07	24.73	8.34	340	-	56 J	<0.5	<0.5	<0.5	<0.5	-	-	70	<50	33	<0.5	<0.5	4	
MW-4	12/01/2010	33.07	25.13	7.94	570	-	64 J	<0.5	<0.5	<0.5	<0.5	-	-	110	<50	-	-	-	-	
MW-4	05/04/2011	33.07	24.50	8.57	-	60 J	<50	<0.5	<0.5	<0.5	<0.5	-	-	25	<50	49	<0.5	<0.5	<0.5	
MW-4	12/09/2011	33.07	25.12	7.95	140	-	56 J	<0.5	<0.5	<0.5	<0.5	-	-	18	<50	-	-	-	-	
MW-4	05/31/2012	33.07	24.75	8.32	140	-	<50	<0.5	<0.5	<0.5	<0.5	-	-	17	<50	60	<0.5	<0.5	0.7 J	
MW-4	11/14/2012	33.07	25.22	7.85	-	<50	<50	<0.5	<0.5	<0.5	<0.5	-	-	21	<50	-	-	-	-	
MW-4	06/03/2013	33.07	25.28	7.79	-	<50	<50	<0.5	<0.5	<0.5	<0.5	-	-	7	<50	21	<0.5	<0.5	<0.5	
MW-4	12/12/2013	33.07	26.09	6.98	100	-	<50	<0.5	<0.5	<0.5	<0.5	-	-	12	<50	-	-	-	-	
MW-5	04/08/1999	30.93	-	-	<50	-	<50	<0.5	<0.5	<0.5	<0.5	<2.0 / <2.5	-	-	<500	<100	<2.0	<2.0	<2.0	
MW-5	06/17/1999	30.93	26.00	4.93	53.8 ¹	-	<50	<0.5	<0.5	<0.5	<0.5	<2.5	-	-	-	-	-	-	-	
MW-5	09/29/1999	30.93	26.20	4.73	<50	-	<50	<0.5	<0.5	<0.5	<0.5	<2.5	-	-	-	-	-	-	-	
MW-5	12/14/1999	30.93	26.32	4.61	<50 ²	-	<50	<0.5	<0.5	<0.5	<0.5	0.598	-	-	-	-	-	-	-	
MW-5	03/09/2000 ³	30.93	25.93	5.00	<50	-	<50	<0.5	<0.5	<0.5	<0.5	<2.5	-	-	-	-	-	-	-	
MW-5	06/10/2000	30.93	25.72	5.21	-	-	<50.0	<0.500	<0.500	<0.500	<0.500	<2.50	-	-	-	-	-	-	-	
MW-5	09/30/2000	30.93	26.14	4.79	130 ⁸	-	<50	<0.50	<0.50	<0.50	<0.50	<2.5	-	-	-	-	-	-	-	
MW-5	12/22/2000	30.93	26.33	4.60	250 ⁸	-	<50	<0.50	<0.50	<0.50	<0.50	9.1	-	-	-	-	-	-	-	
MW-5	03/01/2001	30.93	26.16	4.77	77.4 ⁷	-	<50.0	<0.500	<0.500	<0.500	<0.500	<2.50	-	-	-	-	-	-	-	
MW-5	05/04/2001	30.93	26.04	4.89	-	-	-	-	-	-	-	-	-	-	-	-	-	-	-	
MW-5	09/05/2001	30.93	26.21	4.72	-	-	-	-	-	-	-	-	-	-	-	-	-	-	-	

TABLE 1

GROUNDWATER MONITORING AND SAMPLING DATA
 CHEVRON SERVICE STATION 94800
 1700 CASTRO ST.
 OAKLAND, CALIFORNIA

Location	Date	TOC	DTW	GWE	HYDROCARBONS			PRIMARY VOCS						ADDITIONAL VOCS						
					TPH-DRO	TPH-DRO w/ Si Ge	TPH-GRO	B	T	E	X	MTBE by VOC	MTBE by SW8240	MTBE by SW8260	ETHANOL	TBA	DIPE	ETBE	TAME	
	Units	ft	ft	ft-amsl	µg/L	µg/L	µg/L	µg/L	µg/L	µg/L	µg/L	µg/L	µg/L	µg/L	µg/L	µg/L	µg/L	µg/L	µg/L	µg/L
MW-5	12/21/2001	30.93	26.20	4.73	110	-	<50	<0.50	<0.50	<0.50	<1.5	<2.5	-	-	-	-	-	-	-	-
MW-5	03/15/2002	30.93	25.87	5.06	-	-	-	-	-	-	-	-	-	-	-	-	-	-	-	-
MW-5	06/15/2002	30.93	25.98	4.95	<50	-	<50	<0.50	<0.50	<0.50	<1.5	<2.5	-	-	-	-	-	-	-	-
MW-5	09/06/2002	30.93	26.18	4.75	-	-	-	-	-	-	-	-	-	-	-	-	-	-	-	-
MW-5	12/06/2002	30.93	26.32	4.61	<50	-	<50	<0.50	<0.50	<0.50	<1.5	<2.5	-	-	-	-	-	-	-	-
MW-5	03/03/2003	30.93	25.99	4.94	-	-	-	-	-	-	-	-	-	-	-	-	-	-	-	-
MW-5	06/17/2003 ¹⁴	30.93	25.87	5.06	<50	-	<50	<0.5	<0.5	<0.5	<0.5	-	-	<0.5	-	-	-	-	-	-
MW-5	09/16/2003	30.93	26.09	4.84	-	-	-	-	-	-	-	-	-	-	-	-	-	-	-	-
MW-5	12/31/2003 ¹⁴	30.93	26.21	4.72	<50	-	<50	<0.5	<0.5	<0.5	<0.5	-	-	<0.5	<50	-	-	-	-	-
MW-5	03/26/2004	30.93	25.74	5.19	-	-	-	-	-	-	-	-	-	-	-	-	-	-	-	-
MW-5	08/17/2004	30.93	-	-	-	-	-	-	-	-	-	-	-	-	-	-	-	-	-	-
MW-6	04/08/1999	30.58	-	-	-	-	<50	<0.5	<0.5	<0.5	<0.5	5.6 / 4.5	-	-	<500	<100	<2.0	<2.0	<2.0	
MW-6	06/17/1999	30.58	24.59	5.99	<50	-	<50	<0.5	<0.5	<0.5	<0.5	<2.5	-	-	-	-	-	-	-	
MW-6	09/29/1999	30.58	24.77	5.81	<50	-	<50	<0.5	<0.5	<0.5	<0.5	4.46	-	-	-	-	-	-	-	
MW-6	12/14/1999	30.58	24.84	5.74	<50 ²	-	<50	<0.5	<0.5	<0.5	<0.5	4.13	-	-	-	-	-	-	-	
MW-6	03/09/2000 ³	30.58	24.09	6.49	<50	-	<50	<0.5	<0.5	<0.5	<0.5	2.82	-	-	-	-	-	-	-	
MW-6	06/10/2000	30.58	24.00	6.58	-	-	<50.0	<0.500	<0.500	<0.500	<0.500	<2.50	-	-	-	-	-	-	-	
MW-6	09/30/2000	30.58	24.58	6.00	110 ⁸	-	<50	<0.50	<0.50	<0.50	<0.50	7.3	-	-	-	-	-	-	-	
MW-6	12/22/2000	30.58	24.83	5.75	100 ⁸	-	<50	<0.50	<0.50	<0.50	<0.50	4.5	-	-	-	-	-	-	-	
MW-6	03/01/2001	30.58	24.51	6.07	141 ⁷	-	<50.0	<0.500	<0.500	<0.500	<0.500	7.52	-	-	-	-	-	-	-	
MW-6	05/04/2001	30.58	24.32	6.26	<50	-	<50.0	<0.500	<5.00	<5.00	<5.00	2.74	-	-	-	-	-	-	-	
MW-6	09/05/2001	30.58	24.59	5.99	-	-	-	-	-	-	-	-	-	-	-	-	-	-	-	
MW-6	12/21/2001	30.58	24.65	5.93	200	-	<50	<0.50	<0.50	<0.50	<1.5	8.5	-	-	-	-	-	-	-	

TABLE 1

**GROUNDWATER MONITORING AND SAMPLING DATA
CHEVRON SERVICE STATION 94800
1700 CASTRO ST.
OAKLAND, CALIFORNIA**

Location	Date	TOC	DTW	GWE	HYDROCARBONS			PRIMARY VOCS						ADDITIONAL VOCS						
					TPH-DRO	TPH-DRO w/ Si Ge	TPH-GRO	B	T	E	X	MTBE by VOC	MTBE by SW8240	MTBE by SW8260	ETHANOL	TBA	DIPE	ETBE	TAME	
	Units	ft	ft	ft-amsl	µg/L	µg/L	µg/L	µg/L	µg/L	µg/L	µg/L	µg/L	µg/L	µg/L	µg/L	µg/L	µg/L	µg/L	µg/L	µg/L
MW-6	03/15/2002	30.58	24.14	6.44	-	-	-	-	-	-	-	-	-	-	-	-	-	-	-	-
MW-6	06/15/2002	30.58	24.33	6.25	<50	-	<50	<0.50	<0.50	<0.50	<1.5	4.3	-	-	-	-	-	-	-	-
MW-6	09/06/2002	30.58	24.60	5.98	-	-	-	-	-	-	-	-	-	-	-	-	-	-	-	-
MW-6	12/06/2002	30.58	24.79	5.79	64	-	<50	<0.50	<0.50	<0.50	<1.5	5.0	-	-	-	-	-	-	-	-
MW-6	03/03/2003	30.58	24.44	6.14	-	-	-	-	-	-	-	-	-	-	-	-	-	-	-	-
MW-6	06/17/2003 ¹⁴	30.58	24.11	6.47	<50	-	<50	<0.5	<0.5	<0.5	<0.5	-	-	13	-	-	-	-	-	-
MW-6	09/16/2003	30.58	24.52	6.06	-	-	-	-	-	-	-	-	-	-	-	-	-	-	-	-
MW-6	12/31/2003 ¹⁴	30.58	24.58	6.00	<50	-	<50	<0.5	<0.5	<0.5	0.5	-	-	14	<50	-	-	-	-	-
MW-6	03/26/2004	30.58	23.89	6.69	-	-	-	-	-	-	-	-	-	-	-	-	-	-	-	-
MW-6	08/17/2004	30.58	-	-	-	-	-	-	-	-	-	-	-	-	-	-	-	-	-	-
MW-7	05/04/2001 ¹¹	31.90	27.87	4.03	<50	-	<50.0	<0.500	<5.00	<5.00	<5.00	567	-	470 ¹²	<500	57	<2.0	<2.0	11	
MW-7	09/05/2001	31.90	28.04	3.86	<50	-	<50	<0.50	<0.50	<0.50	<1.5	1,400	-	1,300 ¹²	<500	<100	<2.0	<2.0	32	
MW-7	12/21/2001	31.90	28.86	3.04	210	-	<50	<0.50	<0.50	<0.50	<1.5	620	-	670 ¹²	<500	<100	<2.0	<2.0	15	
MW-7	03/15/2002	31.90	27.72	4.18	<50	-	<50	<0.50	<0.50	<0.50	<1.5	350 / 320	-	350 ¹²	<500	<100	<2.0	<2.0	8	
MW-7	06/15/2002	31.90	27.84	4.06	<50	-	<50	<0.50	<0.50	<0.50	<1.5	850	-	960 ¹²	-	<100	<2.0	<2.0	18	
MW-7	09/06/2002	31.90	27.97	3.93	<50	-	59	<0.50	<0.50	<0.50	<1.5	1,900	-	-	-	-	-	-	-	
MW-7	12/06/2002	31.90	28.03	3.87	<50	-	68	<0.50	<0.50	<0.50	<1.5	2,200	-	-	-	-	-	-	-	
MW-7	03/03/2003	31.90	27.69	4.21	<50	-	<50	<0.50	<0.50	<0.50	<1.5	1,300	-	-	-	-	-	-	-	
MW-7	06/17/2003 ¹⁴	31.90	27.76	4.14	<50	-	79	<0.5	<0.5	<0.5	<0.5	-	-	2,500	-	37	<0.5	<0.5	53	
MW-7	09/16/2003 ¹⁴	31.90	27.83	4.07	<50 ¹⁷	-	110	<5	<5	<5	<5	-	-	4,400	<500	-	-	-	-	
MW-7	12/31/2003 ¹⁴	31.90	27.86	4.04	<50	-	76	<2.0	<2.0	<2.0	<2.0	-	-	3,000	<200	-	-	-	-	
MW-7	03/26/2004 ¹⁴	31.90	27.65	4.25	<50	-	61	<1	<1	<1	<1	-	-	2,000	-	-	-	-	-	
MW-7	08/17/2004 ¹⁴	31.90	27.88	4.02	2,200	-	130	<5	<5	<5	<5	-	-	8,000	<500	<50	<5	<5	140	

TABLE 1

GROUNDWATER MONITORING AND SAMPLING DATA
 CHEVRON SERVICE STATION 94800
 1700 CASTRO ST.
 OAKLAND, CALIFORNIA

Location	Date	TOC	DTW	GWE	HYDROCARBONS			PRIMARY VOCS						ADDITIONAL VOCS						
					TPH-DRO	TPH-DRO w/ Si Ge	TPH-GRO	B	T	E	X	MTBE by VOC	MTBE by SW8240	MTBE by SW8260	ETHANOL	TBA	DIPE	ETBE	TAME	
	Units	ft	ft	ft-amsl	µg/L	µg/L	µg/L	µg/L	µg/L	µg/L	µg/L	µg/L	µg/L	µg/L	µg/L	µg/L	µg/L	µg/L	µg/L	µg/L
MW-7	11/16/2004 ¹⁴	34.35	27.87	6.48	<50	-	200	<3	<3	<3	<3	-	-	7,300	<250	-	-	-	-	-
MW-7	02/18/2005 ¹⁴	34.35	27.60	6.75	64	-	86	<10	<10	<10	<10	-	-	5,700	<1,000	-	-	-	-	-
MW-7	05/06/2005 ¹⁴	34.35	27.43	6.92	60	-	160	<5	<5	<5	<5	-	-	8,400	<500	<50	<5	<5	140	-
MW-7	08/05/2005 ¹⁴	34.35	27.65	6.70	81 ¹⁸	-	500	<5	<5	<5	<5	-	-	20,000 ¹⁹	<500	-	-	-	-	-
MW-7	11/07/2005 ¹⁴	34.35	27.79	6.56	68	-	300	<10	<10	<10	<10	-	-	24,000	<1,000	-	-	-	-	-
MW-7	02/06/2006 ¹⁴	34.35	27.54	6.81	72 ²¹	-	300	<0.5	<0.5	<0.5	<0.5	14,000	-	-	<50	-	-	-	-	-
MW-7	05/08/2006 ¹⁴	34.35	27.15	7.20	94	-	80	<2.0	<2.0	3	7	6,500	-	-	<200	-	-	-	-	-
MW-7	08/08/2006 ¹⁴	34.35	27.53	6.82	150	-	520	<10	<10	<10	<10	17,000	-	-	<1,000	-	-	-	-	-
MW-7	11/08/2006 ¹⁴	34.35	27.75	6.60	440	-	900	<5	<5	<5	<5	41,000	-	-	<500	-	-	-	-	-
MW-7	02/06/2007 ¹⁴	34.35	27.76	6.59	200	-	590	<5	<5	<5	<5	-	-	31,000	<500	-	-	-	-	-
MW-7	05/01/2007 ¹⁴	34.35	27.65	6.70	190	-	380	<3	<3	<3	<3	-	-	14,000	<250	<10	<3	<3	260	-
MW-7	07/31/2007 ¹⁴	34.35	27.75	6.60	270	-	570	<3	<3	<3	<3	-	-	15,000	<250	-	-	-	-	-
MW-7	11/08/2007 ¹⁴	34.35	27.83	6.52	150	-	520	<5	<5	<5	<5	-	-	25,000	<500	-	-	-	-	-
MW-7	02/04/2008 ¹⁴	34.35	27.69	6.66	87	-	540	<1	<1	<1	<1	-	-	17,000	<100	-	-	-	-	-
MW-7	05/01/2008 ¹⁴	34.35	27.72	6.63	<50	-	230	<5	<5	<5	<5	-	-	10,000	<500	<20	<5	<5	170	-
MW-7	08/01/2008 ¹⁴	34.35	27.84	6.51	<50	-	330	<3	<3	<3	<3	-	-	12,000	<250	-	-	-	-	-
MW-7	11/13/2008 ¹⁴	34.35	28.01	6.34	64	-	390	<10	<10	<10	<10	-	-	16,000	<1,000	-	-	-	-	-
MW-7	02/23/2009 ¹⁴	34.35	27.65	6.70	100	-	270	<3	<3	<3	<3	-	-	11,000	<250	-	-	-	-	-
MW-7	05/20/2009	34.35	27.55	6.80	48 J	-	210	<1	<1	<1	<1	-	-	6,300	<100	31	<1	<1	120	-
MW-7	08/25/2009	34.35	27.70	6.65	<100 U	-	160	<3	<3	<3	<3	-	-	5,700	<250	-	-	-	-	-
MW-7	11/18/2009	34.35	27.77	6.58	250	-	100	<1	<1	<1	<1	-	-	2,800	<130	-	-	-	-	-
MW-7	05/18/2010	34.35	27.51	6.84	160	-	76 J	<1	<1	<1	<1	-	-	2,400	<100	<4	<1	2	52	-
MW-7	12/01/2010	34.35	27.71	6.64	120	-	230	<0.5	<0.5	<0.5	<0.5	-	-	7,000	<50	-	-	-	-	-
MW-7	05/04/2011	34.35	27.35	7.00	-	85 J	150	<0.5	<0.5	<0.5	<0.5	-	-	4,200	<50	<2	<0.5	1	100	-

TABLE 1

GROUNDWATER MONITORING AND SAMPLING DATA
 CHEVRON SERVICE STATION 94800
 1700 CASTRO ST.
 OAKLAND, CALIFORNIA

Location	Date	TOC	DTW	GWE	HYDROCARBONS			PRIMARY VOCS						ADDITIONAL VOCS						
					TPH-DRO	TPH-DRO w/ Si Ge	TPH-GRO	B	T	E	X	MTBE by VOC	MTBE by SW8240	MTBE by SW8260	ETHANOL	TBA	DIPE	ETBE	TAME	
	Units	ft	ft	ft-amsl	µg/L	µg/L	µg/L	µg/L	µg/L	µg/L	µg/L	µg/L	µg/L	µg/L	µg/L	µg/L	µg/L	µg/L	µg/L	µg/L
MW-7	12/09/2011	34.35	26.15	8.20	66 J	-	250	<0.5	<0.5	<0.5	<0.5	-	-	7,400	<50	-	-	-	-	
MW-7	05/31/2012	34.35	27.40	6.95	81 J	-	240	<3	<3	<3	<3	-	-	10,000	<250	<10	<3	<3	230	
MW-7	11/14/2012	34.35	27.47	6.88	-	<50	320	<0.5	<0.5	<0.5	<0.5	-	-	8,200	<50	-	-	-	-	
MW-7	06/03/2013	34.35	27.80	6.55	-	<50	60 J	<0.5	<0.5	<0.5	<0.5	-	-	1,400	<50	<2	<0.5	0.7 J	33	
MW-7	12/12/2013	34.35	28.80	5.55	350	-	160	2	<0.5	<0.5	3	-	-	50	<50	-	-	-	-	
QA	12/21/2001	-	-	-	-	-	<50	<0.50	<0.50	<0.50	<1.5	<2.5	-	-	-	-	-	-	-	
QA	03/15/2002	-	-	-	-	-	<50	<0.50	<0.50	<0.50	<1.5	<2.5	-	-	-	-	-	-	-	
QA	06/15/2002	-	-	-	-	-	<50	<0.50	<0.50	<0.50	<1.5	<2.5	-	-	-	-	-	-	-	
QA	09/06/2002	-	-	-	-	-	<50	<0.50	<0.50	<0.50	<1.5	<2.5	-	-	-	-	-	-	-	
QA	12/06/2002	-	-	-	-	-	<50	<0.50	<0.50	<0.50	<1.5	<2.5	-	-	-	-	-	-	-	
QA	06/17/2003 ¹⁴	-	-	-	-	-	<50	<0.5	<0.5	<0.5	<0.5	-	-	<0.5	-	-	-	-	-	
QA	09/16/2003 ¹⁴	-	-	-	-	-	<50	<0.5	<0.5	<0.5	<0.5	-	-	<0.5	-	-	-	-	-	
QA	12/31/2003 ¹⁴	-	-	-	-	-	<50	<0.5	<0.5	<0.5	<0.5	-	-	<0.5	-	-	-	-	-	
QA	03/26/2004 ¹⁴	-	-	-	-	-	<50	<0.5	<0.5	<0.5	<0.5	-	-	<0.5	-	-	-	-	-	
QA	08/17/2004 ¹⁴	-	-	-	-	-	<50	<0.5	<0.5	<0.5	<0.5	-	-	<0.5	-	-	-	-	-	
QA	11/16/2004 ¹⁴	-	-	-	-	-	<50	<0.5	<0.5	<0.5	<0.5	-	-	<0.5	-	-	-	-	-	
QA	02/18/2005 ¹⁴	-	-	-	-	-	<50	<0.5	<0.5	<0.5	<0.5	-	-	<0.5	-	-	-	-	-	
QA	05/06/2005 ¹⁴	-	-	-	-	-	<50	<0.5	<0.5	<0.5	<0.5	-	-	<0.5	-	-	-	-	-	
QA	08/05/2005 ¹⁴	-	-	-	-	-	<50	<0.5	<0.5	<0.5	<0.5	-	-	<0.5	-	-	-	-	-	
QA	11/07/2005 ¹⁴	-	-	-	-	-	<50	0.6	<0.5	<0.5	<0.5	-	-	<0.5	-	-	-	-	-	
QA	02/06/2006 ¹⁴	-	-	-	-	-	<50	<0.5	<0.5	<0.5	<0.5	<0.5	-	-	-	-	-	-	-	
QA	05/08/2006 ¹⁴	-	-	-	-	-	<50	<0.5	<0.5	<0.5	<0.5	<0.5	-	-	-	-	-	-	-	
QA	08/08/2006 ¹⁴	-	-	-	-	-	<50	<0.5	<0.5	<0.5	<0.5	<0.5	-	-	-	-	-	-	-	

TABLE 1

GROUNDWATER MONITORING AND SAMPLING DATA
 CHEVRON SERVICE STATION 94800
 1700 CASTRO ST.
 OAKLAND, CALIFORNIA

Location	Date	TOC	DTW	GWE	HYDROCARBONS			PRIMARY VOCS						ADDITIONAL VOCS					
					TPH-DRO	TPH-DRO w/ Si Ge	TPH-GRO	B	T	E	X	MTBE by VOC	MTBE by SW8240	MTBE by SW8260	ETHANOL	TBA	DIPE	ETBE	TAME
	Units	ft	ft	ft-amsl	µg/L	µg/L	µg/L	µg/L	µg/L	µg/L	µg/L	µg/L	µg/L	µg/L	µg/L	µg/L	µg/L	µg/L	µg/L
Trip Blank	12/17/1997	-	-	-	-	-	<50	<0.5	<0.5	<0.5	<0.5	<2.5	-	-	-	-	-	-	-
Trip Blank	03/18/1998	-	-	-	-	-	<50	<0.5	<0.5	<0.5	<0.5	<2.5	-	-	-	-	-	-	-
Trip Blank	06/28/1998	-	-	-	-	-	<50	<0.5	<0.5	<0.5	<0.5	-	<2.5	-	-	-	-	-	-
Trip Blank	09/07/1998	-	-	-	-	-	<50	<0.5	<0.5	<0.5	<0.5	<2.5	-	-	-	-	-	-	-
Trip Blank	12/09/1998	-	-	-	-	-	<50	<0.5	<0.5	<0.5	<0.5	<2.5	-	-	-	-	-	-	-
Trip Blank	03/11/1999	-	-	-	-	-	<50	<0.5	<0.5	<0.5	<0.5	<5.0	-	-	-	-	-	-	-
Trip Blank	06/17/1999	-	-	-	-	-	<50	<0.5	<0.5	<0.5	<0.5	<2.5	-	-	-	-	-	-	-
Trip Blank	12/14/1999	-	-	-	-	-	<50	<0.5	<0.5	<0.5	<0.5	<2.5	-	-	-	-	-	-	-
Trip Blank	03/09/2000 ³	-	-	-	-	-	<50	<0.5	<0.5	<0.5	<0.5	<2.5	-	-	-	-	-	-	-
Trip Blank	06/10/2000	-	-	-	-	-	<50.0	<0.500	<0.500	<0.500	<0.500	<2.50	-	-	-	-	-	-	-
Trip Blank	09/30/2000	-	-	-	-	-	<50	<0.50	<0.50	<0.50	<0.50	<2.5	-	-	-	-	-	-	-
Trip Blank	12/22/2000 ¹⁰	-	-	-	-	-	<50	<0.50	<0.50	<0.50	<0.50	<2.5	-	-	-	-	-	-	-
Trip Blank	03/01/2001	-	-	-	-	-	<50.0	<0.500	<0.500	<0.500	<0.500	<2.50	-	-	-	-	-	-	-
Trip Blank	05/04/2001	-	-	-	-	-	<50.0	<0.500	<5.00	<5.00	<5.00	<0.500	-	-	-	-	-	-	-
Trip Blank	09/05/2001	-	-	-	-	-	<50	<0.50	<0.50	<0.50	<1.5	<2.5	-	-	-	-	-	-	-

Abbreviations and Notes:

TOC = Top of casing

DTW = Depth to water

GWE = Groundwater elevation

(ft-amsl) = Feet above mean sea level

ft = Feet

µg/L = Micrograms per liter

TPH-DRO = Total petroleum hydrocarbons - diesel range organics

**GROUNDWATER MONITORING AND SAMPLING DATA
CHEVRON SERVICE STATION 94800
1700 CASTRO ST.
OAKLAND, CALIFORNIA**

Location	Date	TOC	DTW	GWE	HYDROCARBONS			PRIMARY VOCS						ADDITIONAL VOCS						
					TPH-DRO	TPH-DRO w/Si Ge	TPH-GRO	B	T	E	X	MTBE by VOC	MTBE by SW8240	MTBE by SW8260	ETHANOL	TBA	DIPE	ETBE	TAME	
	Units	ft	ft	ft-amsl	µg/L	µg/L	µg/L	µg/L	µg/L	µg/L	µg/L	µg/L	µg/L	µg/L	µg/L	µg/L	µg/L	µg/L	µg/L	µg/L

TPH-GRO = Total petroleum hydrocarbons - gasoline range organics

VOCS = Volatile organic compounds

B = Benzene

T = Toluene

E = Ethylbenzene

X = Xylenes (Total)

MTBE = Methyl tertiary butyl ether

TBA = Tert-butyl alcohol

DIPE = Di-isopropyl ether

ETBE = Ethyl t-butyl ether

TAME = Tert-amyl methyl ether

-- = Not available / not applicable

<x = Not detected above laboratory method detection limit

J = Estimated Value (The result is ≥ the method detection limit and < the limit of quantitation)

- 1 Chromatogram pattern indicates an unidentified hydrocarbon.
- 2 Sample was extracted outside EPA recommended holding time.
- 3 TPH-G, BTEX and MTBE was analyzed outside EPA recommended holding time.
- 4 EPA Method 8240.
- 5 Confirmation run.
- 6 Laboratory report indicates gasoline C6-C12.
- 7 Laboratory report indicates unidentified hydrocarbons C9-C24.
- 8 Laboratory report indicates unidentified hydrocarbons >C16.
- 9 Laboratory report indicates unidentified hydrocarbons C9-C40.
- 10 Laboratory report indicates this sample was analyzed outside of the EPA recommended holding time.

**GROUNDWATER MONITORING AND SAMPLING DATA
CHEVRON SERVICE STATION 94800
1700 CASTRO ST.
OAKLAND, CALIFORNIA**

Location	Date	TOC	DTW	GWE	HYDROCARBONS			PRIMARY VOCs						ADDITIONAL VOCs						
					TPH-DRO	TPH-DRO w/ Si Ge	TPH-GRO	B	T	E	X	MTBE by VOC	MTBE by SW8240	MTBE by SW8260	ETHANOL	TBA	DIPE	ETBE	TAME	
	Units	ft	ft	ft-amsl	µg/L	µg/L	µg/L	µg/L	µg/L	µg/L	µg/L	µg/L	µg/L	µg/L	µg/L	µg/L	µg/L	µg/L	µg/L	µg/L

- 11 Well development performed.
- 12 MTBE by EPA Method 8260.
- 14 BTEX and MTBE by EPA Method 8260.
- 15 Laboratory report indicates the surrogate data for the method blank is outside QC limits. Results from the re-extraction are within the limits. The hold time had expired prior to re-extraction so all results are reported from the original extract. The TPH-D result from the re-extraction is 910 ppb.
- 16 Laboratory report indicates the surrogate data for the method blank is outside QC limits. Results from the re-extraction are within the limits. The hold time had expired prior to re-extraction so all results are reported from the original extract. The TPH-D result from the re-extraction is 1,700 ppb.
- 17 Laboratory report indicates the surrogate data for the method blank is outside QC limits. Results from the re-extraction are within the limits. The hold time had expired prior to re-extraction so all results are reported from the original extract. Similar results were obtained in both extracts.
- 18 Laboratory report indicates the observed sample pattern is not typical of #2 fuel/diesel. It elutes in the DRO range later than #2 fuel.
- 19 Analytical result confirmed.
- 20 Laboratory report indicates the observed sample pattern includes #2 fuel/diesel and an additional pattern which elutes later in the DRO range.
- 21 Laboratory report indicates the observed sample pattern is not typical of #2 fuel/diesel. The reported result is due to individual peak(s) eluting in the DRO range.

APPENDIX D

TREND GRAPHS AND DEGRADATION CALCULATIONS

**Table A - Summary of Degradation Rate Calculations
Chevron Service Station 94800, 1700 Castro Street, Oakland, California**

Well	Analyte	Maximum Concentration (ug/L)	Current Concentration (ug/L)	Half-Life (years)	Date to Reach WQO	Years to reach WQOs
MW-1	MTBE	590	1	0.94	Oct 2013	-0.3
MW-2	MTBE	13,000	0.7 J	1.50	Oct 2013	-0.3
MW-3	TPHd	310	140	6.46	Feb 2012	-2.0
	TPHg	8,650	110	3.93	Jun 2013	-0.7
	Benzene	1,040	1	2.15	Jan 2017	2.9
	MTBE	3,300	74	1.69	Jan 2019	5.0
MW-4	MTBE	7,840	12	1.65	Jun 2015	1.3
MW-7	MTBE	41,000	50	1.45	Dec 2024	10.8

Notes and Abbreviations:

- TPHd = Total petroleum hydrocarbons as diesel
- TPHg = Total petroleum hydrocarbons as gasoline
- MTBE = Methyl tertiary butyl ether
- ug/L = Micrograms per liter
- WQO = Water Quality Objective
- J = Estimated value between the method detection limit and laboratory reporting limit

Predicted Time to Reach Water Quality Objectives (WQO) in Well MW-1
Chevron Service Station 94800, 1700 Castro Street, Oakland, California

$$y = b e^{ax} \quad \implies \quad x = \ln(y/b) / a$$

where: y = concentration in µg/L a = decay constant
 b = concentration at time (x) x = time (x) in days

Given		Constituent	Methyl Tertiary Butyl Ether (MTBE)
WQO:	y		5
Constant:	b		1.62E+37
Constant:	a		-2.02E-03
Starting date for current trend:			5/8/2006

Calculate			
Attenuation Half Life (years):	$(-\ln(2)/a)/365.25$		0.94
Estimated Date to Reach WQO:	$(x = \ln(y/b) / a)$		Oct 2013

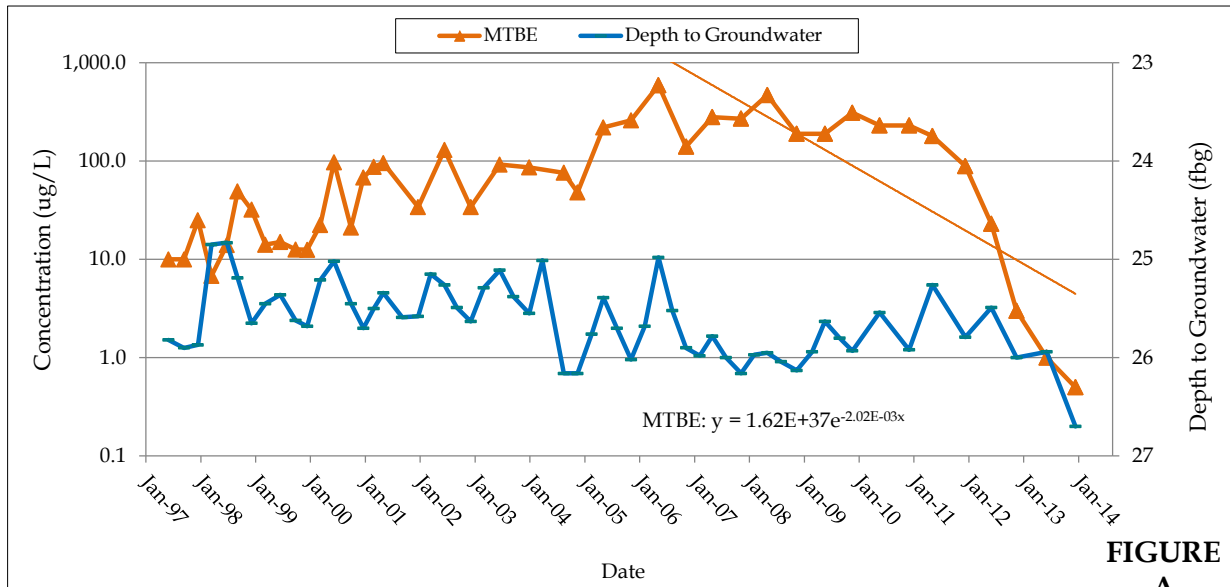

FIGURE A

CHEVRON SERVICE STATION 94800
 1700 CASTRO STREET
 OAKLAND CALIFORNIA



MW-1: MTBE CONCENTRATIONS AND DEPTH TO GROUNDWATER

Predicted Time to Reach Water Quality Objectives (WQO) in Well MW-2
Chevron Service Station 94800, 1700 Castro Street, Oakland, California

$$y = b e^{ax} \quad \implies \quad x = \ln(y/b) / a$$

where: y = concentration in $\mu\text{g/L}$ a = decay constant
 b = concentration at time (x) x = time (x) in days

		Constituent	Methyl Tertiary Butyl Ether (MTBE)
Given	WQO:	y	5
	Constant:	b	3.08E+23
	Constant:	a	-1.26E-03
	Starting date for current trend:		3/18/1998

Calculate	Attenuation Half Life (years):	$(-\ln(2)/a)/365.25$	1.50
	Estimated Date to Reach WQO:	$(x = \ln(y/b) / a)$	Oct 2013

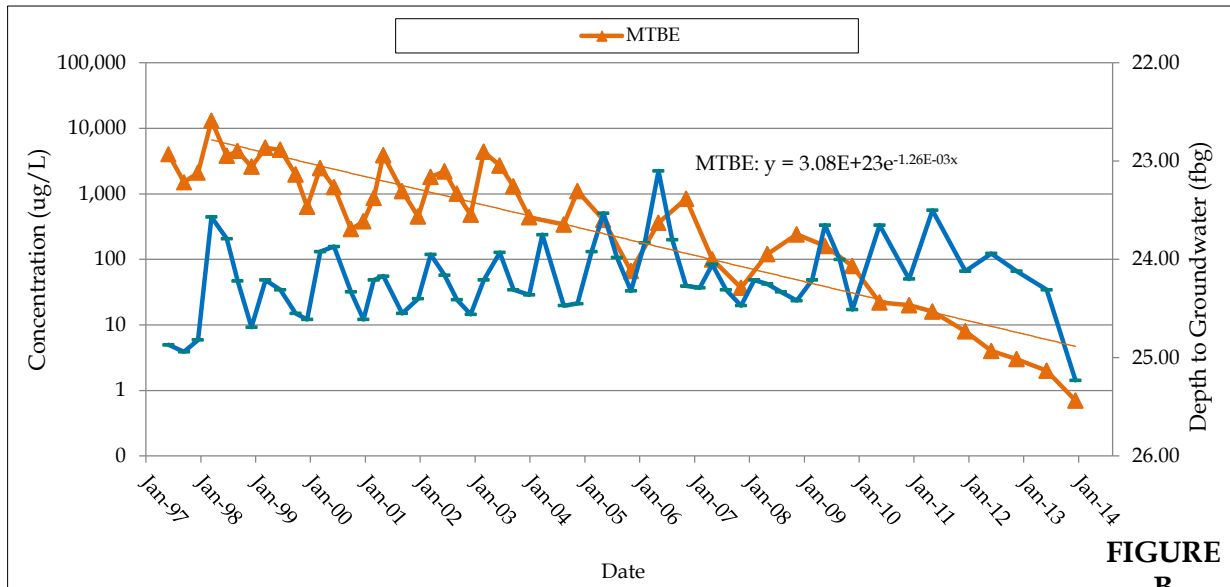

**FIGURE
B**

CHEVRON SERVICE STATION 94800
 1700 CASTRO STREET
 OAKLAND CALIFORNIA



MW-2: MTBE CONCENTRATIONS AND
 DEPTH TO GROUNDWATER

Predicted Time to Reach Water Quality Objectives (WQO) in Well MW-3 Chevron Service Station 94800, 1700 Castro Street, Oakland, California

$$y = b e^{ax} \quad \implies \quad x = \ln(y/b) / a$$

where: y = concentration in $\mu\text{g/L}$ a = decay constant
 b = concentration at time (x) x = time (x) in days

		Constituent	Benzene	Methyl Tertiary Butyl Ether (MTBE)
Given	WQO:	y	1	5
	Constant:	b	2.49E+16	7.11E+21
	Constant:	a	-8.83E-04	-1.12E-03
	Starting date for current trend:		12/14/1999	5/8/2006

Calculate	Attenuation Half Life (years):	$(-\ln(2)/a)/365.25$	2.15	1.69
	Estimated Date to Reach WQO:	$(x = \ln(y/b) / a)$	Jan 2017	Jan 2019

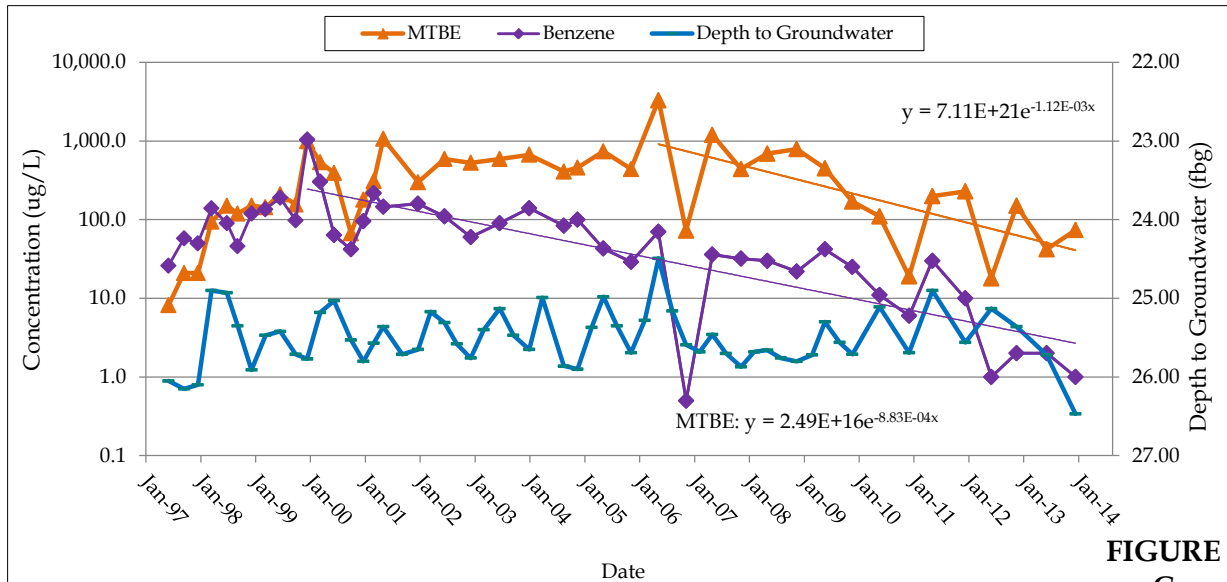

CHEVRON SERVICE STATION 94800
1700 CASTRO STREET
OAKLAND CALIFORNIA



MW-3: BENZENE AND MTBE
CONCENTRATIONS AND DEPTH TO
GROUNDWATER

Predicted Time to Reach Water Quality Objectives (WQO) in Well MW-3 Chevron Service Station 94800, 1700 Castro Street, Oakland, California

$$y = b e^{ax} \quad \implies \quad x = \ln(y/b) / a$$

where: y = concentration in $\mu\text{g/L}$ a = decay constant
 b = concentration at time (x) x = time (x) in days

		Constituent	Total Petroleum Hydrocarbons as Diesel (TPHd)	Total Petroleum Hydrocarbons as Gasoline (TPHg)
Given	WQO:	y	100	100
	Constant:	b	1.69E+07	4.95E+10
	Constant:	a	-2.94E-04	-4.83E-04
	Starting date for current trend:		5/8/2006	12/14/1999

Calculate	Attenuation Half Life (years):	$(-\ln(2)/a)/365.25$	6.46	3.93
	Estimated Date to Reach WQO:	$(x = \ln(y/b) / a)$	Feb 2012	Jun 2013

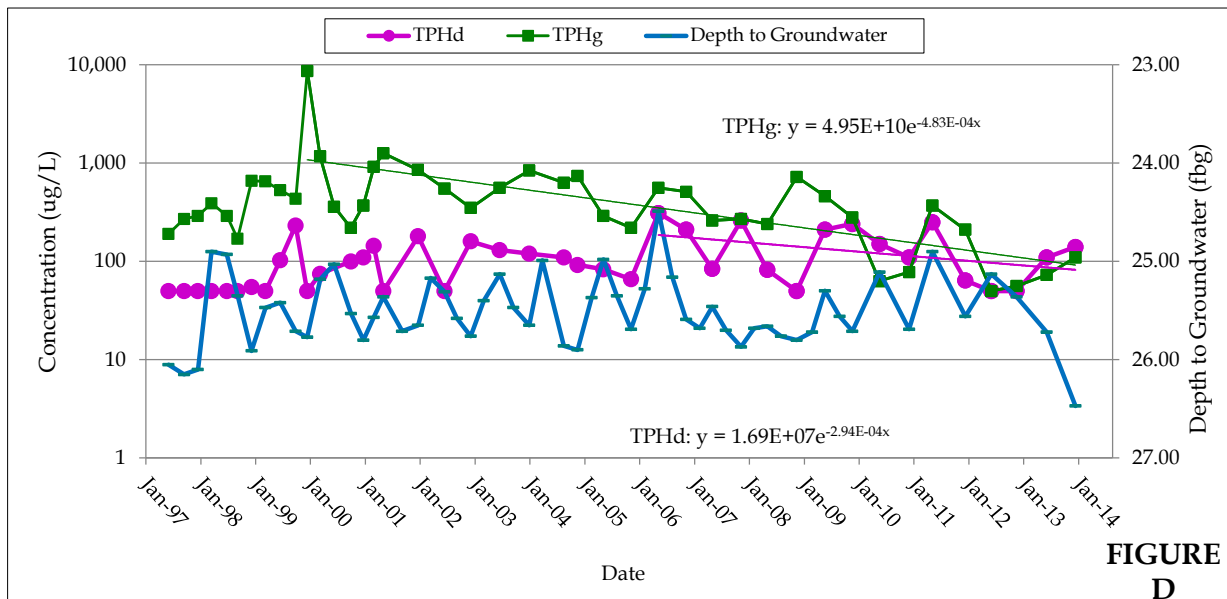

**FIGURE
D**

CHEVRON SERVICE STATION 94800
1700 CASTRO STREET
OAKLAND CALIFORNIA



MW-3: TPHD AND TPHG
CONCENTRATIONS AND DEPTH TO
GROUNDWATER

Predicted Time to Reach Water Quality Objectives (WQO) in Well MW-4
Chevron Service Station 94800, 1700 Castro Street, Oakland, California

$$y = b e^{ax} \quad \implies \quad x = \ln(y/b) / a$$

where: y = concentration in $\mu\text{g/L}$ a = decay constant
 b = concentration at time (x) x = time (x) in days

		Constituent	Methyl Tertiary Butyl Ether (MTBE)
<u>Given</u>			
WQO:	y	5	
Constant:	b	5.29E+21	
Constant:	a	-1.15E-03	
Starting date for current trend:		9/29/1999	
<u>Calculate</u>			
Attenuation Half Life (years):	$(-\ln(2)/a)/365.25$	1.65	
Estimated Date to Reach WQO:	$(x = \ln(y/b) / a)$	Jun 2015	

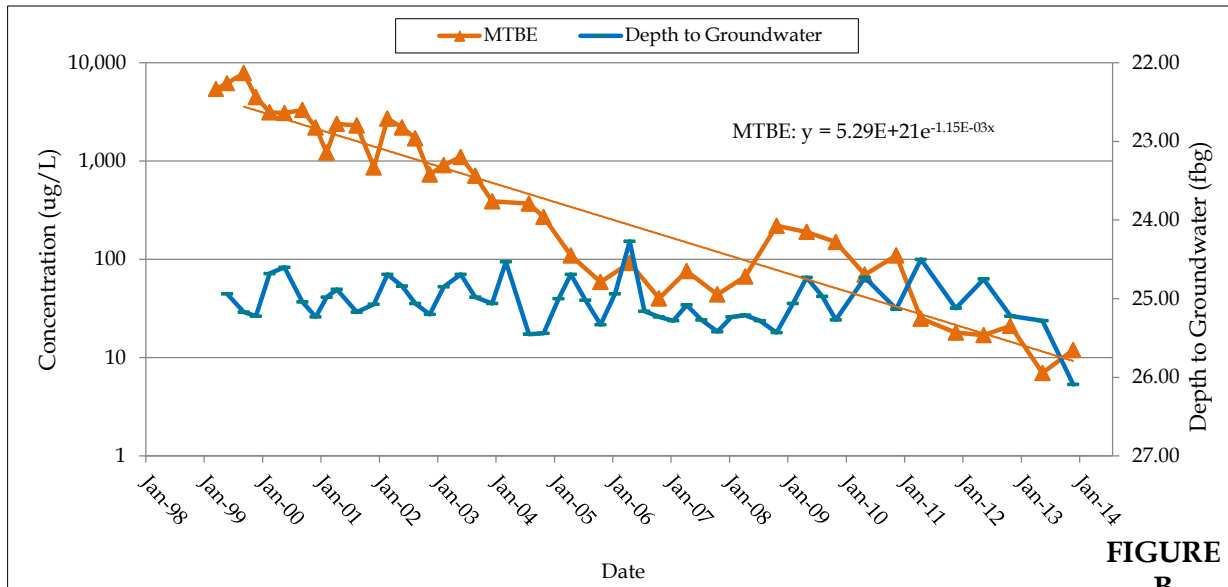

FIGURE B

CHEVRON SERVICE STATION 94800
 1700 CASTRO STREET
 OAKLAND CALIFORNIA



MW-4: MTBE CONCENTRATIONS AND
 DEPTH TO GROUNDWATER

Predicted Time to Reach Water Quality Objectives (WQO) in Well MW-7
Chevron Service Station 94800, 1700 Castro Street, Oakland, California

$$y = b e^{ax} \quad \implies \quad x = \ln(y/b) / a$$

where: y = concentration in $\mu\text{g/L}$ a = decay constant
 b = concentration at time (x) x = time (x) in days

		Constituent	Methyl Tertiary Butyl Ether (MTBE)
Given	WQO:	y	5
	Constant:	b	5.30E+26
	Constant:	a	-1.31E-03
	Starting date for current trend:		11/8/2006

Calculate	Attenuation Half Life (years):	$(-\ln(2)/a)/365.25$	1.45
	Estimated Date to Reach WQO:	$(x = \ln(y/b) / a)$	Dec 2024

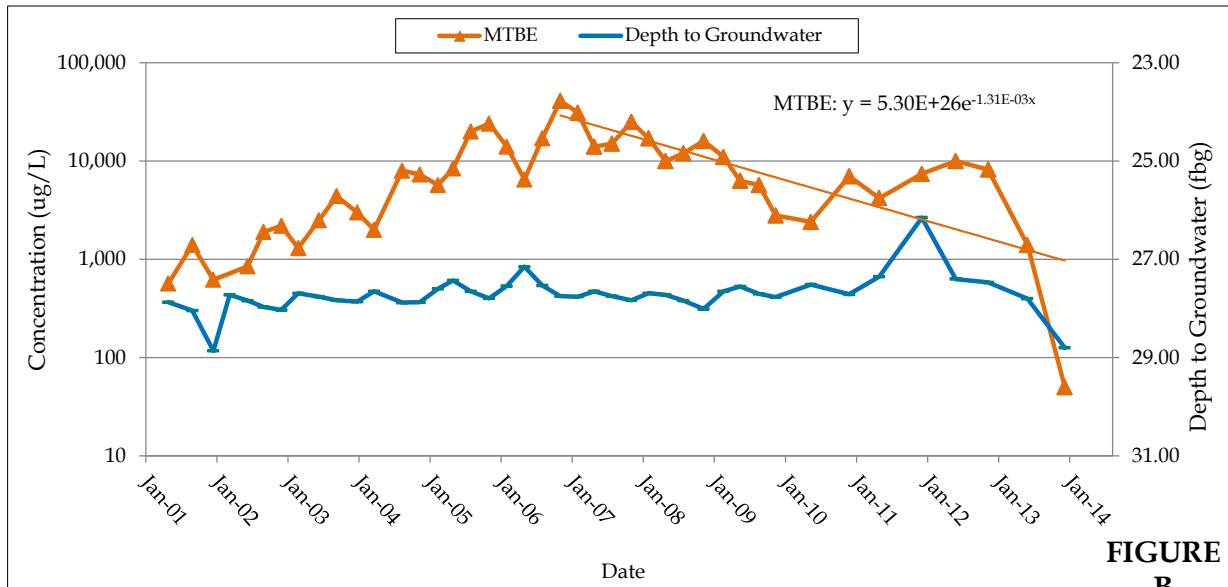

FIGURE B

CHEVRON SERVICE STATION 94800
 1700 CASTRO STREET
 OAKLAND CALIFORNIA



MW-7: MTBE CONCENTRATIONS AND
 DEPTH TO GROUNDWATER

APPENDIX E

SWRCB LOW-THREAT UNDERGROUND STORAGE TANK
CASE CLOSURE POLICY EVALUATION

SWRCB Low-Threat Underground Storage Tank (UST) Case Closure Policy Evaluation
76 Service Station No. 6965
3014 Studebaker Road, Long Beach, California

General Criteria

Is the unauthorized release located within the service area of a public water system? YES

Does the unauthorized release consist only of petroleum? YES
(crude oil and fractions thereof, including motor fuels, jet fuels, fuel oils, lubricants, petroleum solvents, used oil, and additives such as oxygenates)

Has the unauthorized ("primary") release from the UST system been stopped? YES
(USTs, piping, and dispensers removed, repaired, or replaced)

Has free product been removed to the maximum extent practicable? N/A

Has a Conceptual Site Model (CSM) that assesses the nature, extent, and mobility of the release been developed? YES
CSM includes the following:
Establishes source of unauthorized release
Describes all affected media
Describes local geology, hydrogeology and other physical site characteristics that affect contaminant fate and transport in environment
Identifies receptors including water supply wells, surface water bodies, nearby structures and their inhabitants

Has secondary source been removed to the extent practicable? YES
Secondary source is defined as petroleum-impacted soil and groundwater located at or immediately below point of release
"To the extent practicable" defined as implementing a cost-effective corrective action that removes or destroys-in-place most readily recoverable fraction of source-area mass. Additional corrective action not required under policy unless needed to abate threat to human health or groundwater plume does not meet low-threat definition.

Has soil or groundwater been tested for MTBE and results reported in accordance with Health and Safety Code Section 25296.15? YES
Not required for sites with only diesel or jet fuel releases

Does nuisance as defined by Water Code section 13050 exist at the site? NO
"Nuisance" is defined as anything which meets all of the following requirements:
1 Is injurious to health, or is indecent or offensive to the senses, or an obstruction to the free use of property, so as to interfere with the comfortable enjoyment of life or property.
2 Affects at the same time an entire community or neighborhood, or any considerable number of persons, although the extent of the annoyance or damage inflicted upon individuals may be unequal.
3 Occurs during, or as a result of, the treatment or disposal of wastes.
For the purpose of this policy, waste means a petroleum release.

Are there unique site attributes or site-specific conditions that demonstrably increase the risk associated with residual petroleum constituents? NO
Not required for sites with only diesel or jet fuel releases

SWRCB Low-Threat Underground Storage Tank (UST) Case Closure Policy Evaluation
76 Service Station No. 6965
3014 Studebaker Road, Long Beach, California

Media-Specific Criteria

1) Groundwater

To satisfy the media-specific criteria for groundwater, the contaminant plume that exceeds water quality objectives (WQOs) must be stable or decreasing in areal extent and meet all of the additional characteristics of one of the five classes of sites:

Is the contaminant plume that exceeds WQOs stable or decreasing in areal extent?

YES

Does the contaminant plume that exceeds WQOs meet all of the additional characteristics of one of the five classes of sites?

YES
CLASS 5

Groundwater plume length is defined by extent of petroleum hydrocarbon concentrations. TPHd is not included as indicator of plume length because hydrocarbons that will dissolve at measurable amounts are C14 or smaller aromatics and C7 or smaller aliphatics, which are mainly covered in TPHg range.

- 1 Extent of the plume that exceeds WQOs <100' in length.
No free product.
Nearest water supply well or surface water >250' from defined plume boundary.
- 2 Extent of the plume that exceeds WQOs <250' in length.
No free product.
Nearest water supply well or surface water >1,000' from defined plume boundary.
Dissolved benzene <3,000 µg/L and dissolved MTBE <1,000 µg/L.
- 3 Extent of the plume that exceeds WQOs <250' in length.
Free product beneath site, but not offsite.
Plume stable or decreasing for ≥5 years
Nearest water supply well or surface water >1,000' from defined plume boundary.
Property owner willing to accept deed restriction if required.
- 4 Extent of the plume that exceeds WQOs <1,000' in length.
No free product.
Nearest water supply well or surface water >1,000' from defined plume boundary.
Dissolved benzene and MTBE <1,000 µg/L.
- 5 Site-specific conditions indicate that under current and reasonably anticipated near-term future scenarios, the contaminant plume poses a low threat to human health and safety and to the environment and WQOs will be achieved within a reasonable time frame.
"Reasonable time frame" for plumes of limited extent is multiple decades or longer as determined in State Water Board closure order WQ 98-04.

For sites with releases that have not affected groundwater, do mobile constituents (leachate, vapors, or light non-aqueous phase liquids) contain sufficient mobile constituents to cause groundwater to exceed the groundwater criteria?

N/A

2) Petroleum Vapor Intrusion to Indoor Air

The site is considered low-threat for vapor intrusion to indoor air if site-specific conditions satisfy all of the characteristics of one of the three classes of sites (a through c) or if the exception for active commercial fueling facilities applies.

Is the site an active commercial petroleum fueling facility?

YES

Exception: Satisfaction of the media-specific criteria for petroleum vapor intrusion to indoor air is not required at active commercial petroleum fueling facilities, except in cases where release characteristics can be reasonably believed to pose an unacceptable health risk.

SWRCB Low-Threat Underground Storage Tank (UST) Case Closure Policy Evaluation
76 Service Station No. 6965
3014 Studebaker Road, Long Beach, California

a. *Do site-specific conditions at the release site satisfy all of the applicable characteristics and criteria of scenarios 1 through 3 or all of the applicable characteristics and criteria of scenario 4?*

N/A
N/A

Applies only to release sites and impacted or potentially impacted adjacent parcels where; existing buildings are occupied or may be reasonably expected to be occupied in the future, or buildings for human occupancy are reasonably expected to be constructed in near future.

Scenario 1 and 2:

Scenario 1 and 2 apply to sites with LNAPL in soil and/or groundwater

- 1 Depth to groundwater with LNAPL is $\leq 30'$ below building foundation.
 LNAPL on groundwater is unweathered*.
 Total TPH (TPHg and TPHd) in soil within 30' below building foundation is < 100 mg/kg
- 2 Depth to groundwater is $> 30'$ below building foundation.
 Unweathered* LNAPL in soil is $\geq 30'$ from building foundation in all directions.
 Total TPH in soil within 30' of building foundation in all directions is < 100 mg/kg.
 *unweathered LNAPL is petroleum product that has not been subjected to significant volatilization or solubilization, and therefore has not lost a significant portion of its volatile or soluble constituents (e.g., comparable to recently dispensed fuel).

Scenario 3:

Scenario 3 applies to sites without LNAPL, but has dissolved benzene in groundwater

- 3a Depth to groundwater is $\geq 5'$ below building foundation.
 Dissolved benzene in groundwater is < 100 $\mu\text{g/L}$.
 Total TPH in soil within 5' below building foundation is < 100 mg/kg
 Within 5' below building foundation, no data on oxygen concentration in soil or oxygen is $< 4\%$
- 3b Depth to groundwater is $\geq 10'$ below building foundation.
 Dissolved benzene in groundwater is $< 1,000$ $\mu\text{g/L}$.
 Total TPH in soil within 10' below building foundation is < 100 mg/kg
 Within 10' below building foundation, no data on oxygen concentration in soil or oxygen is $< 4\%$
- 3c Depth to groundwater is $\geq 5'$ below building foundation.
 Dissolved benzene in groundwater is $< 1,000$ $\mu\text{g/L}$.
 Total TPH in soil within 5' below building foundation is < 100 mg/kg
 Within 5' below building foundation, oxygen concentration in soil is $\geq 4\%$.

Scenario 4:

Scenario 4 applies to direct soil gas sampling, with vapor samples collected 5' below existing building foundation, or 5' below ground surface for future construction

4a Screening levels for sites with bioattenuation zone (total TPH < 100 mg/kg in upper 5' of soil at two depths, and $\geq 4\%$ oxygen in soil at 5' sample depth)

	Residential	Commercial
Constituent	Soil Gas Concentration ($\mu\text{g}/\text{m}^3$)	
Benzene	$< 85,000$	$< 280,000$
Ethylbenzene	$< 1,100,000$	$< 3,600,000$
Naphthalene	$< 93,000$	$< 310,000$

4b Screening levels for sites without bioattenuation zone (same as California Human Health Screening Levels [CHHSLs])

	Residential	Commercial
Constituent	Soil Gas Concentration ($\mu\text{g}/\text{m}^3$)	
Benzene	< 85	< 280
Ethylbenzene	$< 1,100$	$< 3,600$
Naphthalene	< 93	< 310

**SWRCB Low-Threat Underground Storage Tank (UST) Case Closure Policy Evaluation
76 Service Station No. 6965
3014 Studebaker Road, Long Beach, California**

b. *Has a site-specific risk assessment for the vapor intrusion pathway been conducted and demonstrates that human health is protected to the satisfaction of the regulatory agency?* N/A

c. *As a result of controlling exposure through the use of mitigation measures or through the use of institutional or engineering controls, has the regulatory agency determined that petroleum vapors migrating from soil or groundwater will have no significant risk of adversely affecting human health?* N/A

3) Direct Contact and Outdoor Air Exposure

The site is considered low-threat for direct contact and outdoor air exposure if site-specific conditions satisfy one of the three classes of sites (a through c).

a. *Are maximum concentrations of petroleum constituents in soil less than or equal to those listed in Table 1 for the specified depth below ground surface?* NO

Table 1

Chemical	Residential		Commercial/Industrial		Utility Worker
	0-5 feet bgs mg/kg	Volatilization to outdoor air (5-10 feet bgs) mg/kg	0-5 feet bgs mg/kg	Volatilization to outdoor air (5-10 feet bgs) mg/kg	0-10 feet bgs mg/kg
Benzene	1.9	2.8	8.2	12	14
Ethylbenzene	21	32	89	134	314
Naphthalene	9.7	9.7	45	45	219
PAH [^]	0.063	NA	0.68	NA	4.5

([^] Based on 7 carcinogenic PAHs as benzo(a)pyrene toxicity equivalent. Sampling and analysis for PAH is only necessary where soil is affected by either waste oil or Bunker C fuel)

b. *Are maximum concentrations of petroleum constituents in soil less than levels that a site specific risk assessment demonstrates will have no significant risk of adversely affecting human health?* NO

c. *As a result of controlling exposure through the use of mitigation measures or through the use of institutional or engineering controls, has the regulatory agency determined that the concentrations of petroleum constituents in soil will have no significant risk of adversely affecting human health?* YES

NOTES:

- TPH Total petroleum hydrocarbons
- TPHg Total petroleum hydrocarbons as gasoline
- TPHd Total petroleum hydrocarbons as diesel
- MTBE Methyl tertiary-butyl ether

Site Name:
 Site Address:

Site meets the criteria of the Low-Threat Underground Storage Tank (UST) Case Closure Policy as described below.¹

<p><u>General Criteria</u> General criteria that must be satisfied by all candidate sites:</p> <p>Is the unauthorized release located within the service area of a public water system?</p> <p>Does the unauthorized release consist only of petroleum?</p> <p>Has the unauthorized (“primary”) release from the UST system been stopped?</p> <p>Has free product been removed to the maximum extent practicable?</p> <p>Has a conceptual site model that assesses the nature, extent, and mobility of the release been developed?</p> <p>Has secondary source been removed to the extent practicable?</p> <p>Has soil or groundwater been tested for MTBE and results reported in accordance with Health and Safety Code Section 25296.15?</p> <p>Does nuisance as defined by Water Code section 13050 exist at the site?</p> <p>Are there unique site attributes or site-specific conditions that demonstrably increase the risk associated with residual petroleum constituents?</p>	<p><input checked="" type="checkbox"/> Yes <input type="checkbox"/> No</p> <p><input checked="" type="checkbox"/> Yes <input type="checkbox"/> No</p> <p><input checked="" type="checkbox"/> Yes <input type="checkbox"/> No</p> <p><input type="checkbox"/> Yes <input type="checkbox"/> No <input checked="" type="checkbox"/> NA</p> <p><input checked="" type="checkbox"/> Yes <input type="checkbox"/> No</p> <p><input checked="" type="checkbox"/> Yes <input type="checkbox"/> No</p> <p><input checked="" type="checkbox"/> Yes <input type="checkbox"/> No</p> <p><input type="checkbox"/> Yes <input checked="" type="checkbox"/> No</p> <p><input type="checkbox"/> Yes <input checked="" type="checkbox"/> No</p>
<p><u>Media-Specific Criteria</u> Candidate sites must satisfy all three of these media-specific criteria:</p> <p>1. Groundwater: To satisfy the media-specific criteria for groundwater, the contaminant plume that exceeds water quality objectives must be stable or decreasing in areal extent, and meet all of the additional characteristics of one of the five classes of sites:</p> <p>Is the contaminant plume that exceeds water quality objectives stable or decreasing in areal extent?</p> <p>Does the contaminant plume that exceeds water quality objectives meet all of the additional characteristics of one of the five classes of sites?</p> <p>If YES, check applicable class: <input type="checkbox"/> 1 <input type="checkbox"/> 2 <input type="checkbox"/> 3 <input type="checkbox"/> 4 <input checked="" type="checkbox"/> 5</p>	<p><input checked="" type="checkbox"/> Yes <input type="checkbox"/> No <input type="checkbox"/> NA</p> <p><input checked="" type="checkbox"/> Yes <input type="checkbox"/> No <input type="checkbox"/> NA</p>

¹ Refer to the Low-Threat Underground Storage Tank Case Closure Policy for closure criteria for low-threat petroleum UST sites.

Site Name:
 Site Address:

<p>For sites with releases that have not affected groundwater, do mobile constituents (leachate, vapors, or light non-aqueous phase liquids) contain sufficient mobile constituents to cause groundwater to exceed the groundwater criteria?</p>	<p><input type="checkbox"/> Yes <input type="checkbox"/> No <input checked="" type="checkbox"/> NA</p>
<p>2. Petroleum Vapor Intrusion to Indoor Air: The site is considered low-threat for vapor intrusion to indoor air if site-specific conditions satisfy all of the characteristics of one of the three classes of sites (a through c) or if the exception for active commercial fueling facilities applies.</p> <p>Is the site an active commercial petroleum fueling facility? Exception: Satisfaction of the media-specific criteria for petroleum vapor intrusion to indoor air is not required at active commercial petroleum fueling facilities, except in cases where release characteristics can be reasonably believed to pose an unacceptable health risk.</p> <p>a. Do site-specific conditions at the release site satisfy all of the applicable characteristics and criteria of scenarios 1 through 3 or all of the applicable characteristics and criteria of scenario 4? If YES, check applicable scenarios: <input type="checkbox"/> 1 <input type="checkbox"/> 2 <input type="checkbox"/> 3 <input type="checkbox"/> 4</p> <p>b. Has a site-specific risk assessment for the vapor intrusion pathway been conducted and demonstrates that human health is protected to the satisfaction of the regulatory agency?</p> <p>c. As a result of controlling exposure through the use of mitigation measures or through the use of institutional or engineering controls, has the regulatory agency determined that petroleum vapors migrating from soil or groundwater will have no significant risk of adversely affecting human health?</p>	<p><input checked="" type="checkbox"/> Yes <input type="checkbox"/> No</p> <p><input type="checkbox"/> Yes <input type="checkbox"/> No <input checked="" type="checkbox"/> NA</p> <p><input type="checkbox"/> Yes <input type="checkbox"/> No <input checked="" type="checkbox"/> NA</p> <p><input type="checkbox"/> Yes <input type="checkbox"/> No <input checked="" type="checkbox"/> NA</p>
<p>3. Direct Contact and Outdoor Air Exposure: The site is considered low-threat for direct contact and outdoor air exposure if site-specific conditions satisfy one of the three classes of sites (a through c).</p> <p>a. Are maximum concentrations of petroleum constituents in soil less than or equal to those listed in Table 1 for the specified depth below ground surface (bgs)?</p> <p>b. Are maximum concentrations of petroleum constituents in soil less than levels that a site specific risk assessment demonstrates will have no significant risk of adversely affecting human health?</p> <p>c. As a result of controlling exposure through the use of mitigation measures or through the use of institutional or engineering controls, has the regulatory agency determined that the concentrations of petroleum constituents in soil will have no significant risk of adversely affecting human health?</p>	<p><input type="checkbox"/> Yes <input checked="" type="checkbox"/> No <input type="checkbox"/> NA</p> <p><input type="checkbox"/> Yes <input type="checkbox"/> No <input checked="" type="checkbox"/> NA</p> <p><input checked="" type="checkbox"/> Yes <input type="checkbox"/> No <input type="checkbox"/> NA</p>