



**Nahas Company, LLC**  
Real Estate Services

1111 Stone Valley Rd.  
Alamo, CA 94507  
P. O. Box 3059  
San Ramon, CA 94583  
925-855-1978  
Fax. 925-855-1414

**RECEIVED**

9:36 am, Feb 25, 2011

Alameda County  
Environmental Health

January 31, 2011

Alameda County Environmental Health  
Attn: Barbara Jakub, P.G.  
1131 Harbor Bay Parkway, Suite 250  
Alameda, CA 94502-6577

**Subject: Status Report**  
**First Half 2010**  
**Former Unocal Service Station**  
**20405 Redwood Road**  
**Castro Valley, California**

Dear Ms. Jakub:

Enclosed please find a copy of the subject Status Report dated January 14, 2011, prepared by BSK Associates.

I declare, under penalty of perjury, that the information and/or recommendations contained in the attached document or report is true and correct to the best of my knowledge.

Sincerely,

Randall Nahas



**STATUS REPORT  
FIRST HALF 2010**

**FORMER UNOCAL SERVICE STATION  
20405 REDWOOD ROAD  
CASTRO VALLEY, CALIFORNIA**

**BSK PROJECT E0805401S**

**PREPARED FOR:**

**MR. RANDALL NAHAS  
P.O. BOX 3049  
SAN RAMON, CA 94583**

**JANUARY 14, 2011**

---

**Engineers, Geologists, Inspectors, and Scientists**

**STATUS REPORT  
FIRST HALF 2010  
FORMER UNOCAL SERVICE STATION  
20405 REDWOOD ROAD  
CASTRO VALLEY, CALIFORNIA**

Prepared for:

Mr. Randall Nahas  
P.O. Box 3059  
San Ramon, CA 94583

BSK Project: E0805401S

January 14, 2011



Jeffrey Yeazell, P.E.  
Project Engineer



Kurt Balasek, P.G., C.H.G.  
Senior Geologist

**BSK Associates**  
3140 Gold Camp Drive, Suite 160  
Rancho Cordova, CA 95670  
(916) 853-9293  
(916) 853-9297 FAX  
[www.bskinc.com](http://www.bskinc.com)

© BSK Associates, 2011. All rights reserved.

**BSK**

## TABLE OF CONTENTS

1.0 INTRODUCTION .....	1
2.0 PROJECT SITE DESCRIPTION AND HISTORY .....	1
3.0 PURPOSE AND SCOPE .....	4
4.0 GROUNDWATER FLOW DIRECTION .....	4
5.0 GROUNDWATER SAMPLING AND ANALYTICAL RESULTS .....	5
6.0 DISCUSSION AND RECOMMENDATIONS.....	5
7.0 LIMITATIONS.....	5
8.0 REFERENCES .....	6

### TABLES

Table 1: Soil Sample Analytical Results

Table 2: Soil Sample Analytical Results – Volatile and Semi-Volatile Organic Compounds

Table 3: Groundwater Monitoring Analytical Results – Petroleum Hydrocarbon Constituents

Table 4: Groundwater Monitoring Analytical Results – Volatile Organic Compounds

Table 5: Summary of Groundwater Elevation Data

Table 6: Summary of Groundwater Flow Direction and Gradient Data

### FIGURES

Figure 1: Site Vicinity Map

Figure 2: Site Plan

Figure 3: Extent of Excavations and Excavation Soil Sample Locations

Figure 4: Generalized Groundwater Elevation Map - August 2010

Figure 5: MW-2 Time Series Plots

Figure 6: MW-3 Time Series Plots

Figure 7: MW-6 Time Series Plots

Figure 8: MW-7 Time Series Plots

Figure 9: MW-101 Time Series Plots

### APPENDICES

Appendix A: Water Sample Logs

Appendix B: Laboratory Data Reports and Chain-of-Custody Documentation

**STATUS REPORT  
FIRST HALF 2010  
FORMER UNOCAL SERVICE STATION  
20405 REDWOOD ROAD  
CASTRO VALLEY, CALIFORNIA**

## **1.0 INTRODUCTION**

At the request of Mr. Randall Nahas, BSK Associates performed groundwater monitoring and prepared this report summarizing data collected from the semi-annual monitoring of six groundwater monitoring wells located at the Former Unocal Service Station, 20405 Redwood Road, Castro Valley, California (the site). The site vicinity is shown on Figure 1.

## **2.0 PROJECT SITE DESCRIPTION AND HISTORY**

**December 1989, Soil Investigation and Monitoring Well Installation:** In December 1989, three groundwater monitoring wells (MW-2, MW-3 and MW-4) were installed at the locations shown on Figure 2. Soil samples were collected from soil borings MW-1 and MW-1A; however, they were not converted to monitoring wells (BSK, 1995). Summaries of soil sample analytical results are presented in Table 1 (petroleum hydrocarbons) and Table 2 (volatile and semi-volatile organic compounds). Monitoring well groundwater sample analytical results are summarized in Table 3.

**March 1991, Soil Investigation:** Thirteen soil borings (SB-1 through SB-13) were advanced at the locations shown on Figure 2 to depths ranging between approximately 10 and 20 feet bgs (BSK, 1996). Soil sample analytical results are summarized in Table 1.

**March through April 1992, Soil Borings and Monitoring Well Installation:** Soil borings MW-5, MW-6, MW-7, SB-14, and SB-15 were drilled at the locations shown on Figure 2. A summary of soil sample analytical results is presented in Table 1. Borings MW-5, MW-6, and MW-7 were completed as groundwater monitoring wells.

**October 1992, Chromatograph Evaluation:** BSK identified a non-standard peak in the chromatograph from a groundwater sample from well MW-7. The peak was not typical of petroleum hydrocarbons.

**November 1992, Groundwater Sampling:** Groundwater samples from monitoring well MW-7 were analyzed for volatile halocarbons by EPA Method 601. Analytical results are summarized in Table 3. Tetrachloroethylene (PCE) and trichloroethylene (TCE) were detected in groundwater samples from well MW-7 at concentrations of 14,000 µg/L and 660 µg/L, respectively. BSK Associates attributed the previous concentrations of TPHg to the presence of PCE and concluded gasoline contamination may not occur in a significant quantity in monitoring well MW-7. As a result, BSK Associates recommended ceasing any further investigation of the gasoline plume south of well MW-7 (BSK, 1992b).

**November 1993, Soil Borings:** Soil borings SP-1 and SP-2 were advanced at the locations shown on Figure 2. Soil and groundwater samples were collected from each boring. Summaries of soil sample analytical results are presented in Table 1 (petroleum hydrocarbons) and Table 2 (volatile and semi-volatile organic compounds). Monitoring well groundwater sample analytical results are summarized in Table 3 (Philip Environmental, 1996).

**December 1995, Feasibility Study:** Excavation and on-site treatment of excavated soil was selected as the remedial alternative for soil impacts. As a part of the feasibility study, an aquifer pump test was conducted. Groundwater extraction well MW-101 was installed at the location shown on Figure 2. Pump-and-treat was determined to be a feasible remedial alternative for groundwater impacts at the site. (BSK, 1995).

**June 1996, Revised Corrective Action Plan:** Philip Environmental prepared a Revised Corrective Action Plan. The plan stated that the site operator and property owner planned to cease operation of the site as a service station, which would require closure of the underground storage tanks. Philip Environmental recommended removal of the USTs, soil excavation and limited groundwater extraction (Philip Environmental, 1996).

As part of the Revised Corrective Action Plan, Tier I and Tier II Risk Assessments were conducted. Results of the Tier I Risk Assessment show benzene levels in soil at the site exceeded the risk based screening levels for volatilization from soil to outdoor air, vapor intrusion from soil to on-site buildings, soil ingestion, and leachate from soil to water exposure pathways. Toluene levels in soil at the site exceeded the risk based screening levels for the vapor intrusion from soil to on-site buildings exposure pathway. Results of the Tier II Risk Assessment indicated that concentrations of phase separated hydrocarbons and benzene in soil and groundwater exceed Tier II site specific screening levels in the area adjacent to the USTs and the southern property boundary (Philip Environmental, 1996).

**Summer 1997, Service Station Building Demolition:** The service station building was demolished and fuel dispensers removed (Life Springs Environmental Inc., 1999).

**November 1998, UST Removal:** The concrete slabs and foundation of the building, fueling area, and pump islands, were broken up and hauled to a recycling facility. The three USTs and associated piping were removed and transported to Ecology Control Industries (ECI) in Richmond, California. Two hydraulic hoists and clarifier sump were also removed. No holes were observed in the gasoline USTs, but small holes were observed in the waste oil UST. The excavated soil (approximately 175 cubic yards) was stockpiled. Figure 3 shows the approximate extent of the excavation.

Soil samples were collected after excavation. Sample locations are shown on Figure 3. Tables 1 and 2 provide summaries of soil sample analytical results. The release of petroleum hydrocarbons at the site appears to have primarily impacted the backfill material surrounding the two 10,000 gallon gasoline USTs (Life Springs Environmental Inc., 1999).

The UST pit was backfilled with aggregate base to within 5 feet of ground surface. Winter weather conditions led Life Springs Environmental Inc. to place impacted soil back in the excavations of the waste oil UST and clarifier sump (Life Springs Environmental Inc., 1999).

**April 1999, Stockpiled Soil Remediation:** Beginning in April 1999, impacted soil from the main UST excavation was laid out in shallow beds and aerated by periodic tilling.

**May 1999, Soil Re-Excavation and Sampling:** The waste oil UST and clarifier sump areas were re-excavated, with the second excavation extending slightly deeper than the first. Excavated soil from the waste oil UST and clarifier sump pits was disposed of at Vasco Road Sanitary Landfill in Livermore, California (Life Springs Environmental Inc., 2000). Soil samples were collected from native soil in both pits and analyzed for TPHd and total oil and grease. A section of the pipe trench area was excavated to a depth of 3 feet bgs. Excavated soil from the trench was laid out in shallow beds for aeration. A soil sample was collected from the trench re-excavation (sample name: GASLINE). The sample was analyzed for TPHg/BTEX and MTBE. Table 1 provides a summary of soil sample analytical results. Figure 3 shows the approximate extent of re-excavation and sample locations.

**August 1999, Waste Oil and Clarifier Sump Pit Sampling and Soil Stockpiling:** The aerated soil from previous excavations was stockpiled. Soil samples were collected from the bottom of the waste oil and clarifier sump pits at depths of 10 and 7 feet bgs respectively (Life Springs Environmental Inc., 1999). Table 1 provides a summary of soil sample analytical results, Figure 3 shows the approximate sample locations.

**September 1999, Waste Oil Pit Sampling:** A soil sample was collected from within the waste oil pit at a depth of 11.5 bgs and analyzed for chlorinated hydrocarbons and TPHd. Table 1 provides a summary of soil sample analytical results, Figure 3 shows the approximate sample location.

**October 1999, Clarifier Sump Pit Sampling:** A soil sample was collected within the clarifier sump pit at a depth of 9.5 feet bgs. Table 1 provides a summary of soil sample analytical results, Figure 3 shows the approximate sample location.

**November 1999, Permission to Re-Use Stockpiled Soil:** Permission was granted by Alameda County Environmental Health Services for the re-use of the stockpiled soil that had been remediated by aeration (Life Springs Environmental Inc., 2000).

**December 1999, Waste Oil and Clarifier Sump Pit Deepening and Sampling:** The waste oil pit was deepened to 10 feet bgs and the clarifier sump pit was deepened to 14 feet bgs. Soil removed from the over-excavation was also transported to the Vasco Road Sanitary Landfill in Livermore, California. Approximately 36.1 tons of soil were removed from both the waste oil pit and the clarifier sump pit during both re-excavation and over-excavation events. Soil samples were collected from the native soil in the bottom of each pit. The two excavations along with the final five feet of the main excavation were filled in with the remediated soil from the main excavation. Table 1 provides a summary of soil sample analytical results. Figure 3 shows the approximate extent of the over-excavation and sample locations.

Monitoring well MW-4 was abandoned by pressure grouting and drilling out. The vault boxes for monitoring wells MW-2 and MW-101 were replaced (Life Springs Environmental Inc., 2000).

**Groundwater Monitoring Program:** From August 1990 through 1999, groundwater monitoring activities were performed on a quarterly basis. Groundwater monitoring was performed semi-annually starting in 1999 through September 2003. Groundwater monitoring was not conducted from the third quarter of 2003 through the third quarter of 2008. Groundwater monitoring analytical data are summarized in Table 3 (petroleum hydrocarbon constituents) and Table 4 (volatile organic hydrocarbons). Groundwater elevation data are summarized in Table 5. Currently, groundwater monitoring is conducted on a semi-annual basis.

### 3.0 PURPOSE AND SCOPE

The purpose of quarterly monitoring is to collect data on groundwater quality, groundwater depths, and direction of flow beneath the subject property with the intention of evaluating residual hydrocarbon contamination in groundwater beneath the site. BSK performed the following tasks:

- Measured depth to groundwater in three of the six monitoring wells on August 4, 2010. At the time of sampling, monitoring wells MW-2 and MW-3 were inaccessible. Monitoring wells MW-2 and MW-3 were covered by a layer of mulch and could not be located.
- Purged and sampled four of the six groundwater monitoring wells.
- Analyzed groundwater samples from each accessible monitoring well, for:
  - Total petroleum hydrocarbons as diesel (TPHd)
  - Total petroleum hydrocarbons as gasoline (TPHg)
  - Benzene, toluene, ethylbenzene, and xylenes (BTEX)
  - Fuel Oxygenates
  - Lead Scavengers
- Prepared this status report summarizing the condition of the wells, depth to groundwater, groundwater flow direction, and laboratory analytical results.

### 4.0 GROUNDWATER FLOW DIRECTION

Groundwater depths were measured in the four accessible monitoring wells prior to purging and sampling on August 4, 2010. Depths were measured relative to the north side of the top of each well casing.

Based on our measurements, groundwater generally flowed east with an approximate hydraulic gradient of 0.01 feet/foot. Figure 4 presents a groundwater elevation contour map for the recent monitoring event, and includes a rose diagram depicting a summary of groundwater flow directions since 1992. Table 5 summarizes groundwater elevations recorded during the investigation. Table 6 summarizes associated groundwater gradient and flow direction data.



## **5.0 GROUNDWATER SAMPLING AND ANALYTICAL RESULTS**

Groundwater sampling was conducted on August 4, 2010. Each well was purged of a minimum of three casing volumes using an electric submersible pump. Water temperature, pH, and conductivity were measured after removal of each approximate casing volume. Water sample logs are included in Appendix A.

After purging, water samples were collected from each well using a clean disposable bailer. The samples were labeled with the sample identification, date and time collected, and project identification. Samples were preserved in a chilled cooler and transported with completed chain-of-custody forms to BSK's state-certified analytical laboratory. The samples were analyzed for TPHd and TPHg by EPA Method 8015B, BTEX by EPA Method 8021B, and fuel oxygenates and lead scavengers by EPA Method 8260B. Equipment used during purging and sampling activities was cleaned with non-phosphate detergent wash and rinsed prior to use at each well location. The purged groundwater was stored in appropriately-labeled 55-gallon drums at the site.

Tables 3 and 4 summarize past quarterly monitoring analytical results. Figures 5 through 9 present time series plots for monitoring wells MW-2, MW-3, MW-6, MW-7, and MW-101 respectively. Appendix B contains laboratory data reports and chain-of-custody documentation for the samples collected this quarter.

## **6.0 DISCUSSION AND RECOMMENDATIONS**

BSK has had significant difficulties in efficiently locating monitoring wells MW-2 and MW-3. Between sampling events, the wells become covered with bark and debris, and we have had minimal success in locating them with GPS devices and metal detectors.

BSK recommends the following:

1. Locate monitoring wells MW-2 and MW-3 and install a crash post next to their vault boxes. The crash posts will allow us to readily locate the wells in the future and also help in protecting the vault boxes from potential damage in the future.

## **7.0 LIMITATIONS**

This report has been prepared for the exclusive use of Mr. Randall Nahas. Unauthorized use of or reliance on the information contained in this report by others, unless given the express written consent by BSK Associates, is prohibited.

The conclusions presented in this report are professional opinions based on the indicated data described in this report. This report has been prepared in accordance with generally accepted methodologies and standards of professional practice. No other warranties, either expressed or implied, are made as to the findings or conclusions included in the report. Conclusions and recommendations are intended only for the purpose, site location and project indicated.

Opinions presented in this report apply to site conditions existing at the time of our study and those reasonably foreseeable. They cannot necessarily apply to site changes of which this office is not aware and has not evaluated. Changes in the conditions of the subject property may occur with time, because of natural processes or the works of man, on the subject site or on adjacent properties.

## 8.0 REFERENCES

- BSK 1992a, *Off Site Soil and Groundwater Contamination Characterization and Seventh Quarterly Groundwater Monitoring Report*, Unocal Service Station 20405 and 20629 Redwood Road, Castro Valley, California, May 29, 1992.
- BSK 1992b, *Letter Report, Well MW-7 Special Sampling, Unocal Service Station/Safeway Parking Lot, 20405 and 20629 Redwood Road, Castro Valley, California*, December 23, 1992.
- BSK 1995, *Feasibility Study, Soil and Groundwater Remediation, Tien's Unocal Station, 20405 Redwood Road, Castro Valley, California*, December 11, 1995.
- BSK, 1996, *Semi-Annual Groundwater Monitoring Report, Unocal 76 Service Station, 20405 and 20629 Redwood Road, Castro Valley, California*, BSK Associates, May 14, 1996.
- Philip Environmental 1996, *Revised Corrective Action Plan, R.T. Nahas Property/Tien Unocal 76 Service Station, 20405 Redwood Road, Castro Valley, California*, June 14, 1996.
- Life Springs Environmental, Inc. 1999, *Technical Report, Tank Closure, Underground Fuel Tank Site, R.T. Nahas Company Property, Formerly Frank Tien Unocal 76 Service Station, 20405 Redwood Road, Castro Valley, California, 94546*, February 18, 1999.
- Life Springs Environmental, Inc. 1999, *Soil Remediation Status Report, R.T. Nahas Property, Castro Valley*, August 17, 1999.
- Life Springs Environmental, Inc. 1999, *Soil Remediation Status Report #2, R.T. Nahas Property, Castro Valley*, October 26, 1999.
- Life Springs Environmental, Inc. 2000, *Technical Report, Soil Remediation Closure Report, Underground Fuel Tank Site, R.T. Nahas Company Property, Formerly Frank Tien Unocal 76 Service Station, 20405 Redwood Road, Castro Valley, California, 94546*, April 13, 2000.
- Graymer, R.W., 2000, *Geologic map and map database of the Oakland metropolitan area, Alameda, Contra Costa, and San Francisco Counties, California: U.S. Geological Survey, Miscellaneous Field Studies Map MF-2342, scale 1:50000*.
- BSK, 2003, *Report, Eighth Semi-Annual Groundwater Monitoring (Third Quarter 2003), Former Unocal 76 Service Station, 20405 and 20629 Redwood Road, Castro Valley, California*, BSK Associates, May 14, 1996.

---

## TABLES

**Table 1**  
**Soil Sample Analytical Results**  
**Petroleum Hydrocarbon Constituents**  
**Former Unocal Service Station**  
**20405 Redwood Road, Castro Valley, California**  
(Concentrations in mg/kg)

Location	Depth (feet)	TPHg	TPHd	Benzene	Toluene	Ethylbenzene	Xylenes	Oil and Grease	Total Lead	MTBE
<b>December 1989, Soil Investigation and Monitoring Well Installation</b>										
<b>MW-1</b>	5	<10	-	<0.02	<0.02	<0.02	<0.02	-	-	-
	10	<b>89</b>	-	<b>1.8</b>	<b>7.8</b>	<b>3.8</b>	<b>20</b>	-	-	-
	15	<10	-	<b>0.09</b>	<0.02	<0.02	<0.02	-	-	-
	19	<10	-	<0.02	<0.02	<0.02	<0.02	-	-	-
<b>MW-1A</b>	5	<10	<10	<0.02	<0.02	<0.02	<0.02	-	<2.0	-
	10	<b>110</b>	<b>50<sup>b</sup></b>	<b>2.2</b>	<b>11</b>	<b>5.4</b>	<b>25</b>	-	<2.0	-
	13	<b>11</b>	<10	<b>0.64</b>	<b>0.71</b>	<b>0.64</b>	<b>3.5</b>	-	<2.0	-
	16.5	<10	<10	<0.02	<0.02	<0.02	<0.02	-	<2.0	-
<b>MW-2</b>	5	<10	-	<0.02	<0.02	<0.02	<0.02	-	-	-
	10	<10	-	<b>0.05</b>	<0.02	<0.02	<b>0.03</b>	-	-	-
	15	<10	-	<0.02	<0.02	<0.02	<0.02	-	-	-
	20	<10	-	<0.02	<0.02	<0.02	<0.02	-	-	-
<b>MW-3</b>	5	<10	-	<0.02	<0.02	<0.02	<0.02	-	-	-
	10	<10	-	<0.02	<0.02	<0.02	<0.02	-	-	-
	15	<b>92</b>	-	ND	ND	<b>0.97</b>	<b>4.0</b>	-	-	-
	19	<10	-	<0.02	<0.02	<0.02	<0.02	-	-	-
<b>MW-4<sup>a</sup></b>	5	-	<10	<0.02	<0.02	<0.02	<0.02	<100	-	-
	8.5	-	<10	<0.02	<0.02	<0.02	<0.02	<100	-	-
	13	-	<10	<0.02	<0.02	<0.02	<0.02	<100	-	-
<b>March 1991, Soil Investigation</b>										
<b>SB-1</b>	14.5	<10	-	<b>0.05</b>	<b>0.03</b>	<0.02	<b>0.06</b>	-	-	-
<b>SB-2</b>	10.5	<b>440</b>	-	<b>4.5</b>	<b>18</b>	<b>11</b>	<b>55</b>	-	<2.0	-
	13	<b>810</b>	<b>340<sup>b</sup></b>	<b>5.3</b>	<b>4.2</b>	<b>13</b>	<b>76</b>	-	-	-
<b>SB-3</b>	13.5	<b>15</b>	<10	<b>0.09</b>	<b>0.18</b>	<b>0.19</b>	<b>1.1</b>	-	<2.0	-
	17	<10	-	<0.02	<0.02	<0.02	<0.02	-	-	-
<b>SB-4</b>	14	<10	<10	<0.02	<0.02	<0.02	<b>0.1</b>	-	-	-
<b>SB-5</b>	14.5	<10	-	<0.02	<0.02	<0.02	<0.02	-	-	-
<b>SB-6</b>	15	<b>310</b>	-	<b>0.8</b>	<b>15</b>	<b>6.2</b>	<b>36</b>	-	-	-
<b>SB-8</b>	20.5	<10	-	<0.02	<0.02	<0.02	<0.02	-	-	-
<b>SB-10</b>	16	<10	-	<0.02	<0.02	<0.02	<0.02	-	-	-
<b>SB-11</b>	10.5	<b>31</b>	-	<b>0.09</b>	<b>0.03</b>	<b>0.49</b>	<b>1.8</b>	-	-	-
<b>SB-12</b>	15.5	<10	-	<0.02	<0.02	<0.02	<0.02	-	-	-
<b>SB-13</b>	10.5	<b>1100</b>	-	<b>5.5</b>	<b>67</b>	<b>27</b>	<b>140</b>	-	-	-
	14	<b>530</b>	-	<b>7.8</b>	<b>48</b>	<b>14</b>	<b>73</b>	-	-	-

**Table 1**  
**Soil Sample Analytical Results**  
**Petroleum Hydrocarbon Constituents**  
**Former Unocal Service Station**  
**20405 Redwood Road, Castro Valley, California**  
(Concentrations in mg/kg)

Location	Depth (feet)	TPHg	TPHd	Benzene	Toluene	Ethylbenzene	Xylenes	Oil and Grease	Total Lead	MTBE
<b>March through April 1992, Soil Borings and Monitoring Well Installation</b>										
SB-14	21	<1	<1	<0.005	<0.005	<0.005	<0.005	-	-	-
SB-15	20.5	<1	3	<0.005	0.007	<0.005	<0.008	-	-	-
MW-5	21	<1	<1	<0.005	<0.005	<0.005	<0.005	-	-	-
MW-6	16	<1	<1	<0.005	<0.005	<0.005	<0.005	-	-	-
MW-7	15.5	<1	<1	<0.005	<0.005	<0.005	<0.005	-	-	-
<b>November 1993, Soil Borings</b>										
SP-2	14	9	-	0.14	0.52	0.19	1.0	-	-	-
SP-1	16	-	-	0.18	<0.005	0.075	0.055	-	-	-
<b>December 1995, Monitoring Well Installation</b>										
MW-101	10	120	-	<0.005	0.95	2.1	11	-	-	-
	15	63	-	ND	1.5	0.87	9.8	-	-	-
<b>November 1998, UST Removal</b>										
WO	8	<1.0	270	<0.005	0.0061	0.027	0.079	2300	9.0	<0.005
PIT NE COR	12	47	-	<0.62	<0.62	0.74	3.4	-	-	<0.62
PIT NE BOT	13	14	-	<0.62	<0.62	<0.62	<0.62	-	-	<0.62
PIT SE	12	31	-	<0.62	1.8	<0.62	3.0	-	-	<0.62
PIT SE	unk	100	-	<2.5	<2.5	2.6	14	-	-	<2.5
PIT SW	11.5	22	-	<0.62	<0.62	<0.62	3.0	-	-	<0.62
PIT NW	12	2.6	-	0.088	0.0054	0.11	0.52	-	-	0.014
WL NW	2	<1.0	-	<0.005	<0.005	<0.005	<0.005	-	-	0.018
WL J	2	<1.0	-	<0.005	<0.005	<0.005	<0.005	-	-	<0.005
WIS S	2	410	-	3.6	11	12	72	-	-	0.80
WIS N	2	<1.0	-	<0.005	<0.005	<0.005	<0.005	-	-	<0.005
EJ	2	<1.0	-	<0.005	<0.005	<0.005	<0.005	-	-	<0.005
EIS S	2	<1.0	-	<0.005	<0.005	<0.005	<0.005	-	-	<0.005
EIS N	2	<1.0	-	<0.005	<0.005	<0.005	<0.005	-	-	<0.005
CJ	2	<1.0	-	<0.005	<0.005	<0.005	<0.005	-	-	<0.005
WEST HOIST <sup>3</sup>	8.5	-	1000* <sup>1</sup>	-	-	-	-	-	-	-
EAST HOIST <sup>3</sup>	8.5	-	<1.0**	-	-	-	-	-	-	-
SUMP	4.5	<1.0	120 <sup>1</sup>	<0.005	<0.005	<0.005	<0.005	96	7.9	<0.005

**Table 1**  
**Soil Sample Analytical Results**  
**Petroleum Hydrocarbon Constituents**  
**Former Unocal Service Station**  
**20405 Redwood Road, Castro Valley, California**  
(Concentrations in mg/kg)

Location	Depth (feet)	TPHg	TPHd	Benzene	Toluene	Ethylbenzene	Xylenes	Oil and Grease	Total Lead	MTBE
<b>May 1999, Soil Re-excavation and Sampling</b>										
GASLINE	3	<1.0	-	<0.005	<0.005	<0.005	<0.005	-	-	-
SUMP	4	-	2700 <sup>1</sup> /4800 <sup>c</sup>	-	-	-	-	-	-	-
WO	9	-	38 <sup>1</sup>	-	-	-	-	140	-	-
<b>August 1999, Waste Oil and Clarifier Sump Pit Sampling</b>										
SUMP	7	-	84	-	-	-	-	88	-	-
WO	10	-	560	-	-	-	-	1400	-	-
<b>September 1999, Waste Oil Pit Sampling</b>										
WO	11.5	<1.0	1.2 <sup>1</sup>	<0.005	<0.005	<0.005	<0.005	<50	-	-
<b>October 1999, Clarifier Sump Pit Sampling</b>										
SUMP <sup>3</sup>	9.5	71 <sup>1</sup>	270 <sup>2</sup>	<0.62	<0.62	<0.62	<0.62	220	-	<0.62
<b>December 1999, Waste Oil and Clarifier Sump Pit Deepening and Sampling</b>										
WO <sup>3</sup>	11	<1.0	<1.0	<0.005	<0.005	<0.005	<0.005	<50	-	<0.005
SUMP <sup>3</sup>	15	6.3 <sup>1</sup>	690 <sup>1</sup>	<0.005	<0.005	0.14	0.25	1200	-	<0.005
Notes:										
-: Not analyzed.										
unk: Unknown.										
<sup>1</sup> : Hydrocarbon reported does not match the pattern of Chromalab, Inc. standard.										
<sup>2</sup> : Estimated concentration reported due to overlapping fuel patterns.										
<sup>3</sup> : Exact location not mapped.										
* West Hoist also had 2000 mg/kg hydraulic oil.										
**East Hoist <50 mg/kg hydraulic oil.										
<sup>a</sup> : Soil samples at were also analyzed for VOCs by EPA method 8010. None were detected.										
<sup>b</sup> : Sample contains lower molecular weight hydrocarbons.										
<sup>c</sup> : Reported as motor oil										

**Table 2**  
**Soil Sample Analytical Results**  
**Volatile and Semi-Volatile Organic Compounds**  
**Former Unocal Service Station**  
**20405 Redwood Road, Castro Valley, California**  
**(Concentrations in mg/kg)**

Well	Depth	Phenanthrene	Fluoranthene	Pyrene	bis(2-Ethylhexyl) phthalate
<b>December 1989, Soil Investigation and Monitoring Well Installation</b>					
MW-4*	5	-	-	-	-
	8.5	-	-	-	-
	13	-	-	-	-
<b>November 1993, Soil Borings</b>					
SP-2*	1	-	-	-	-
SP-1*	16	-	-	-	-
<b>November 1998, UST Removal</b>					
WO	8	0.10	0.17	0.22	0.6
SUMP	4.5	<0.10	<0.10	<0.10	<0.50
<b>August 1999, Waste Oil and Clarifier Sump Pit Sampling</b>					
SUMP	7	<0.10	<0.10	<0.10	<0.50
WO	10	<0.10	0.13	0.20	0.82
<b>September 1999, Waste Oil Pit Sampling</b>					
WO	11.5	<0.10	<0.10	<0.10	<0.50
Notes:					
-: Not analyzed					
*: Samples were analyzed for VOCs by EPA Method 8260 only; none were detected above reportable detection limits					

**Table 3**  
**Groundwater Monitoring Analytical Results**  
**Petroleum Hydrocarbon Constituents**  
**Former Unocal Service Station**  
**20405 Redwood Road, Castro Valley, California**  
(Concentrations in µg/kg)

Well	Date	TPHg	TPHd	Total Oil and Grease	Benzene	Toluene	Ethylbenzene	Xylenes	MTBE
MW-2	12/89	72	-	-	<0.5	<0.5	<0.5	<0.5	-
	8/90	180	-	-	21	3.9	7.2	28	-
	1/91	430	-	-	50	33	22	110	-
	4/91	4,800	-	-	640	520	140	790	-
	7/91	220	-	-	14	1	17	8	-
	10/91	170	-	-	2.9	ND	2.5	6	-
	1/92	5,200	-	-	480	870	160	860	-
	4/20/92	300	-	-	70	0.3	15	7	-
	7/9/92	84	-	-	10	ND	0.6	2.3	-
	10/8/92	ND	-	-	2.3	ND	2.3	3	-
	1/12/93	170	-	-	11	5.1	1.4	6.3	-
	3/4/93	720	-	-	110	32	67	28	-
	7/1/93	220	-	-	17	1.1	6	12	-
	10/19/93	98	-	-	4.0	ND	2.3	3.1	-
	1/12/94	130	-	-	13	3.4	4.9	9.2	-
	4/25/94	270	-	-	23	1.1	8.2	17	-
	7/28/94	180	-	-	14	0.7	5.8	12	-
	10/13/94	97	-	-	2.8	ND	2.9	1.8	-
	1/10/95	440	-	-	48	2.8	15	27	-
	4/19/95	480	-	-	72	2.8	47	22	-
	10/12/95	450	-	-	7.4	ND	5.1	5.5	-
	4/12/96	690	-	-	41	2.8	27	50	-
	10/8/96	180	-	-	9.4	0.5	7.2	9.4	1,400
	4/9/97	470	-	-	23	1.6	21	31.4	1,800
	11/5/97	360	-	-	6.8	0.64	4.7	8.2	1,200
	3/1/00	560	-	-	14	0.92	16	24	1,400
	9/00	180	-	-	0.89	ND	1	0.65	620
	3/22/01	1,000	-	-	ND	ND	ND	ND	1,300 <sup>1</sup> /1,200
	8/23/01	160	-	-	22	1.5	17	27	690 <sup>1</sup> /820
	3/02	140	-	-	2.6	0.31	2	1.7	420
	10/02	92	-	-	ND	ND	ND	ND	280
	03/03	IA	IA	IA	IA	IA	IA	IA	IA
	9/17/03	IA	IA	IA	IA	IA	IA	IA	IA
	11/20/08	IA	IA	IA	IA	IA	IA	IA	IA
	2/11/09*	<50	<50	-	<0.3	<0.3	<0.3	<0.3	62
	8/25/09	CNL	CNL	CNL	CNL	CNL	CNL	CNL	CNL
	8/4/10	CNL	CNL	CNL	CNL	CNL	CNL	CNL	CNL



**Table 3**  
**Groundwater Monitoring Analytical Results**  
**Petroleum Hydrocarbon Constituents**  
**Former Unocal Service Station**  
**20405 Redwood Road, Castro Valley, California**  
(Concentrations in  $\mu\text{g}/\text{kg}$ )

Well	Date	TPHg	TPHd	Total Oil and Grease	Benzene	Toluene	Ethylbenzene	Xylenes	MTBE
MW-3	12/89	<50	-	-	<0.5	<0.5	<0.5	<0.5	-
	8/90	290	-	-	55	3.8	20	59	-
	1/91	110	-	-	29	3.3	9.7	34	-
	4/91	3,600	-	-	450	270	150	760	-
	7/91	220	-	-	14	14	33	8.0	-
	10/91	ND	ND	ND	ND	ND	ND	ND	-
	1/92	60	-	-	4.0	10	2.0	8.0	-
	4/20/92	ND	-	-	1.0	0.4	ND	0.9	-
	7/9/92	ND	-	-	1.3	0.40	ND	1.3	-
	10/8/92	ND	-	-	2.1	ND	ND	0.30	-
	1/12/93	ND	-	-	1.2	1.0	0.60	4.1	-
	3/4/93	330	-	-	32	0.90	64	13	-
	7/1/93	330	-	-	24	11	14	82	-
	10/19/93	ND	-	-	5.0	ND	0.60	1.2	-
	1/12/94	69	-	-	13	3.4	4.9	9.2	-
	4/25/94	62	-	-	17	1.0	4.9	24	-
	7/28/94	52	-	-	7.2	0.4	1.6	4.6	-
	10/13/94	ND	-	-	0.9	ND	ND	ND	-
	1/10/95	250	-	-	26	0.60	14	45	-
	4/19/95	450	-	-	26	0.60	40	19	-
	10/12/95	340	-	-	9.0	3.9	8.5	34	-
	4/12/96	170	-	-	41	2.8	27	50	-
	10/8/96	79	-	-	3.8	1.5	2.1	6.8	55
	4/9/97	120	-	-	7.3	ND	3.3	5.4	230
	11/5/97	62	-	-	1.7	1.4	2.3	8.3	65
	3/1/00	96	-	-	0.61	ND	ND	ND	240
	9/00	ND	-	-	ND	ND	ND	ND	98
	3/22/01	ND	-	-	ND	ND	ND	ND	190
	8/23/01	ND	-	-	ND	ND	ND	ND	26
	3/02	ND	-	-	ND	ND	ND	ND	26
	10/02	ND	-	-	ND	ND	ND	ND	15
	3/03	IA	IA	IA	IA	IA	IA	IA	IA
	9/17/03	ND	-	-	ND	ND	ND	ND	13
11/20/08	IA	IA	IA	IA	IA	IA	IA	IA	
2/11/09*	<50	<50	-	<0.3	<0.3	<0.3	<0.3	12	
8/25/09	CNL	CNL	CNL	CNL	CNL	CNL	CNL	CNL	
8/4/10	CNL	CNL	CNL	CNL	CNL	CNL	CNL	CNL	

**Table 3**  
**Groundwater Monitoring Analytical Results**  
**Petroleum Hydrocarbon Constituents**  
**Former Unocal Service Station**  
**20405 Redwood Road, Castro Valley, California**  
(Concentrations in µg/kg)

Well	Date	TPHg	TPHd	Total Oil and Grease	Benzene	Toluene	Ethylbenzene	Xylenes	MTBE
MW-4	12/89	<50	<100	<5,000	<0.5	<0.5	<0.5	<0.5	-
	08/90	ND	ND	ND	ND	ND	ND	ND	-
	1/91	-	-	-	-	-	-	-	-
	4/91	ND	ND	ND	ND	ND	ND	ND	-
	7/91	-	-	-	-	-	-	-	-
	10/91	ND	ND	ND	ND	ND	ND	ND	-
	1/92	-	-	-	-	-	-	-	-
	4/20/92	ND	ND	ND	ND	ND	ND	ND	-
	7/9/92	-	-	-	-	-	-	-	-
	10/8/92	ND	120	ND	ND	ND	ND	ND	-
	1/12/93	ND	ND	ND	ND	ND	ND	ND	-
	3/4/93	ND	ND	ND	ND	ND	ND	ND	-
	7/1/93	ND	ND	1,000	ND	ND	ND	ND	-
	10/19/93	ND	ND	ND	0.40	ND	ND	0.40	-
	4/25/94	ND	ND	ND	ND	ND	ND	0.40	-
	7/28/94	ND	86	ND	ND	0.60	ND	ND	-
	10/13/94	70	ND	ND	ND	36	ND	1.3	-
	1/10/95	ND	ND	2,000	ND	ND	ND	ND	-
4/19/95	ND	ND	ND	ND	ND	ND	ND	-	
10/12/95	ND	ND	-	ND	ND	ND	ND	-	
4/12/96	ND	ND	-	ND	ND	ND	ND	-	
10/8/96	ND	ND	-	ND	ND	ND	ND	ND	
4/9/97	ND	ND	-	ND	ND	ND	ND	ND	
11/5/97	ND	ND	-	ND	ND	ND	ND	ND	
Abandoned December 1999.									

**Table 3**  
**Groundwater Monitoring Analytical Results**  
**Petroleum Hydrocarbon Constituents**  
**Former Unocal Service Station**  
**20405 Redwood Road, Castro Valley, California**  
(Concentrations in µg/kg)

Well	Date	TPHg	TPHd	Total Oil and Grease	Benzene	Toluene	Ethylbenzene	Xylenes	MTBE
MW-5	4/13/92	ND	-	-	ND	ND	ND	ND	-
	4/27/92	ND	-	-	ND	ND	ND	ND	-
	7/9/92	ND	-	-	ND	ND	ND	ND	-
	10/8/92	ND	-	-	ND	0.40	ND	ND	-
	1/12/93	ND	-	-	ND	ND	ND	ND	-
	3/4/93	ND	-	-	ND	ND	ND	ND	-
	7/1/93	ND	-	-	ND	ND	ND	ND	-
	10/19/93	ND	-	-	ND	ND	ND	ND	-
	4/25/94	ND	-	-	ND	0.40	ND	1.0	-
	7/94	-	-	-	-	-	-	-	-
	10/13/94	87	ND	ND	ND	36	ND	1.3	-
	1/95	-	-	-	-	-	-	-	-
	4/19/95	ND	-	-	ND	ND	ND	ND	-
	10/12/95	ND	-	-	ND	ND	ND	ND	-
	4/12/96	ND	-	-	ND	ND	ND	ND	-
	10/8/96	ND	-	-	ND	ND	ND	ND	ND
	4/9/97	ND	-	-	ND	ND	ND	ND	ND
	11/5/97	ND	ND	-	ND	ND	ND	ND	ND
	3/1/00	ND	-	-	ND	ND	ND	ND	ND
	9/00	ND	-	-	ND	ND	ND	ND	ND
	3/22/01	ND	-	-	ND	ND	ND	ND	ND
	8/23/01	NS	NS	NS	NS	NS	NS	NS	NS
	3/02	NS	NS	NS	NS	NS	NS	NS	NS
	10/02	NS	NS	NS	NS	NS	NS	NS	NS
	3/03	NS	NS	NS	NS	NS	NS	NS	NS
	9/17/03	NS	NS	NS	NS	NS	NS	NS	NS
	11/20/08*	<50	<50	-	-	0.31	<0.3	<0.3	0.38
2/6/09*	<50	<50	-	-	<0.3	<0.3	<0.3	<0.3	<5.0
8/25/09	<50	<50	-	-	<0.5	<0.5	<0.5	<0.5	<5.0
8/4/10	<50	<100	-	-	<0.3	<0.3	<0.3	<0.3	<1.0

**Table 3**  
**Groundwater Monitoring Analytical Results**  
**Petroleum Hydrocarbon Constituents**  
**Former Unocal Service Station**  
**20405 Redwood Road, Castro Valley, California**  
(Concentrations in µg/kg)

Well	Date	TPH <sub>g</sub>	TPH <sub>d</sub>	Total Oil and Grease	Benzene	Toluene	Ethylbenzene	Xylenes	MTBE	
MW-6	4/13/92	ND	-	-	ND	0.30	ND	ND	-	
	4/27/92	ND	-	-	ND	ND	ND	ND	-	
	7/9/92	ND	-	-	ND	ND	ND	ND	-	
	10/8/92	ND	-	-	ND	ND	ND	ND	-	
	1/12/93	ND	-	-	ND	ND	ND	ND	-	
	3/4/93	ND	-	-	ND	ND	ND	ND	-	
	7/1/93	ND	-	-	ND	ND	ND	ND	-	
	10/19/93	ND	-	-	ND	ND	ND	ND	-	
	4/25/94	ND	-	-	ND	0.30	ND	0.40	-	
	7/94	-	-	-	-	-	-	-	-	
	10/13/94	160	-	-	0.40	140	0.5	2.3	-	
	1/95	-	-	-	-	-	-	-	-	
	4/19/95	ND	-	-	ND	ND	ND	ND	-	
	10/12/95	ND	-	-	ND	ND	ND	ND	-	
	4/12/96	ND	-	-	2.9	2.9	ND	ND	-	
	10/8/96	ND	-	-	ND	ND	ND	ND	17	
	4/9/97	ND	-	-	ND	ND	ND	ND	ND	
	11/5/97	ND	ND	-	ND	ND	ND	ND	9.0	
	3/1/00	78	-	-	ND	0.49	ND	ND	260	
	9/00	54	-	-	ND	ND	ND	ND	170	
	3/22/01	130	-	-	ND	ND	ND	ND	440	
	8/23/01	79	-	-	ND	ND	ND	ND	280 <sup>1</sup> /350	
	3/02	91	-	-	ND	ND	ND	ND	370	
	10/02	83	-	-	ND	ND	ND	ND	260	
	3/03	61	-	-	ND	ND	ND	ND	200	
	9/17/03	140	-	-	ND	ND	ND	ND	440	
	11/20/08*	<50	<50	-	0.81	<0.3	<0.3	<0.3	<0.3	300
	2/6/09*	97	<50	-	<0.3	<0.3	<0.3	<0.3	<0.3	200
	8/25/09	NS	NS	NS	NS	NS	NS	NS	NS	NS
	8/4/10	<50	<100	-	<0.3	<0.3	<0.3	<0.3	<0.3	54

**Table 3**  
**Groundwater Monitoring Analytical Results**  
**Petroleum Hydrocarbon Constituents**  
**Former Unocal Service Station**  
**20405 Redwood Road, Castro Valley, California**  
(Concentrations in µg/kg)

Well	Date	TPHg	TPHd	Total Oil and Grease	Benzene	Toluene	Ethylbenzene	Xylenes	MTBE	
MW-7	4/13/92	1,300	-	-	0.40	0.30	0.30	0.9	-	
	4/27/92	1,100	-	-	ND	ND	ND	ND	-	
	7/9/92	830	-	-	ND	ND	ND	ND	-	
	10/8/92	3,900	-	-	ND	ND	ND	ND	-	
	11/30/92	2,700	ND	-	-	-	-	-	-	
	1/12/93	U	U	U	U	U	U	U	U	
	1/93	1,900	-	-	ND	ND	ND	ND	-	
	3/4/93	830	-	-	ND	ND	ND	ND	-	
	7/1/93	680	-	-	ND	ND	ND	ND	-	
	10/19/93	360	-	-	ND	ND	ND	0.70	-	
	1/12/94	330	-	-	ND	ND	ND	ND	-	
	4/25/94	360	-	-	ND	ND	ND	ND	-	
	7/28/94	-	-	-	-	-	-	-	-	
	10/13/94	-	-	-	-	-	-	-	-	
	1/95	-	-	-	-	-	-	-	-	
	4/19/95	-	-	-	-	ND	ND	ND	ND	
	10/12/95	-	-	-	-	ND	ND	ND	ND	
	4/12/96	-	-	-	-	ND	ND	ND	ND	
	10/8/96	-	-	-	-	-	-	-	-	
	4/9/97	-	-	-	-	-	-	-	-	
	11/5/97	-	-	-	-	-	-	-	-	
	3/1/00	ND	-	-	-	890	ND	ND	ND	ND
	9/00	770	-	-	-	3.0	0.32	13	27	ND
	3/22/01	630	-	-	-	ND	ND	ND	ND	ND
	8/23/01	800	-	-	-	ND	ND	ND	ND	7.3 <sup>1</sup> /ND
	3/02	280	-	-	-	0.35	ND	0.91	2.2	7.7
	10/02	IA	IA	IA	IA	IA	IA	IA	IA	IA
	3/03	IA	IA	IA	IA	IA	IA	IA	IA	IA
	9/17/03	IA	IA	IA	IA	IA	IA	IA	IA	IA
	11/20/08	520	70	-	-	<0.3	<0.3	<0.3	<0.3	<5.0
	2/6/09*	400	<50	-	-	<0.3	<0.3	<0.3	<0.3	<5.0
	8/25/09	IA	IA	IA	IA	IA	IA	IA	IA	IA
8/4/10	430	<100	-	-	<0.3	<0.3	<0.3	<0.3	<1	

**Table 3**  
**Groundwater Monitoring Analytical Results**  
**Petroleum Hydrocarbon Constituents**  
**Former Unocal Service Station**  
**20405 Redwood Road, Castro Valley, California**  
(Concentrations in  $\mu\text{g}/\text{kg}$ )

Well	Date	TPH <sub>g</sub>	TPH <sub>d</sub>	Total Oil and Grease	Benzene	Toluene	Ethylbenzene	Xylenes	MTBE
MW-101	9/95	9,400	-	-	170	94	150	710	-
	3/01/00	40,000	-	-	2,500	490	4,300	10,000	2,400 <sup>1</sup> /1,400
	9/00	770	-	-	3.0	0.32	13	27	-
	3/01	34,000	-	-	1,400	62	3,400	7,700	970
	8/23/01	12,000	-	-	630	ND	1,500	480	1,400
	3/02	19,000	-	-	600	25	1,600	3,100	1,600 <sup>1</sup> /870
	10/02	5,200	-	-	240	0.74	230	76	1,500 <sup>1</sup> /1,400
	3/03	6,300	-	-	330	ND	440	370	1,400 <sup>1</sup> /840
	9/17/03	3,000	-	-	150	ND	100	110	850 <sup>1</sup> /1,100
	11/20/08*	2,800	5,400	-	61	<0.3	38	1.6	570
	2/6/09*	<50	3,600	-	<0.3	<0.3	<0.3	<0.3	630
	8/25/09	2,200	1,500	-	9.9	<0.5	14	5.6	440
8/4/10	1,100	<100	-	11	<0.3	12	4.8	280	
SP-1	11/1993	49,000	-	-	3,900	13,000	2,800	15,000	-
SP-2	11/1993	1,400	-	-	54	240	87	390	-

Notes:

ND: Not detected.

<: Not detected above laboratory's indicated reportable detection limit.

NS: No sample collected.

IA: Well inaccessible at time of sampling.

CNL: Could not locate well.

U: Unavailable.

-: Not analyzed.

\*: Other fuel oxygenates and 1,2-DCA not detected above 5  $\mu\text{g}/\text{L}$  (50  $\mu\text{g}/\text{L}$  for TBA).

<sup>1</sup>: MTBE by EPA method 8015/8020; otherwise by EPA Method 8260.

**Table 4**  
**Groundwater Monitoring Analytical Results**  
**Volatile Organic Compounds**  
**Former Unocal Service Station**  
**20405 Redwood Road, Castro Valley, California**  
(Concentrations in µg/kg)

Well	Date	Chlorobenzene	Chloroform	cis-1,2-Dichloroethene	trans-1,2-Dichloroethene	1,2-Dichloroethane	Tetrachloroethene	Trichloroethene
<b>MW-2</b>	3/4/93	<0.5	<0.5	<0.5	<0.5	<b>0.6</b>	<0.5	<0.5
	10/19/93	<0.5	<0.5	<0.5	<0.5	<0.5	<0.5	<0.5
<b>MW-4</b>	12/14/89	<0.5	<0.5	-	<0.5	<0.5	<0.5	<0.5
	3/4/93	<0.5	<0.5	<0.5	<0.5	<0.5	<0.5	<0.5
	10/19/93	<0.5	<0.5	<0.5	<0.5	<0.5	<b>0.7</b>	<b>0.9</b>
<b>MW-5</b>	3/4/93	<0.5	<0.5	<0.5	<0.5	<0.5	<b>0.8</b>	<0.5
<b>MW-6</b>	3/4/93	<0.5	<0.5	<0.5	<0.5	<0.5	<b>3.5</b>	<0.5
<b>MW-7</b>	11/30/92	<b>2.0</b>	<b>2.0</b>	<b>180</b>	<b>1.5</b>	-	<b>14,000</b>	<b>660</b>
	3/4/93	-	<20	-	<20	<20	<b>3,700</b>	<b>210</b>
<b>SP-1</b>	11/18/93	unknown	unknown	<b>28</b>	<b>15</b>	<b>12</b>	<b>22</b>	<b>20</b>
<b>SP-2</b>	11/18/93	unknown	unknown	ND	ND	ND	ND	ND
Notes:								
<: Not detected above laboratory's indicated reportable detection limit.								
-: Not analyzed								

**Table 5**  
**Summary of Groundwater Elevation Data**  
**Former Unocal Service Station**  
**20405 Redwood Road, Castro Valley, California**

<b>Well</b>	<b>Date Measured</b>	<b>Casing Elevation (Feet above MSL)</b>	<b>Depth to Groundwater (Feet)</b>	<b>Groundwater Elevation (Feet above MSL)</b>
<b>MW-101</b>	09/95	U	U	-
	3/1/00		9.75	-
	09/00		U	-
	03/01		U	-
	08/23/01		9.70	-
	03/02		U	-
	10/02		U	-
	03/03		U	-
	9/17/03		9.80	-
	11/20/08		10.69	-
	2/6/09		10.46	-
8/25/09		10.53	-	
8/4/10		11.47	-	
<b>MW-2</b>	12/89	U	U	-
	08/90		U	-
	01/91		U	-
	04/91		U	-
	07/91		U	-
	10/91		U	-
	01/92		U	-
	4/20/92	183.10	10.36	172.74
	7/9/92		10.65	172.45
	10/8/92	183.47	11.60	171.87
	1/12/93		9.11	174.36
	3/4/93		9.28	174.19
	7/1/93		10.37	173.10
	10/19/93		10.82	172.65
	1/12/94		10.66	172.81
	4/25/94		10.23	173.24
	7/28/94		10.70	172.77
	10/13/94		14.19	169.28
	1/10/95		8.12	175.35
	4/19/95		9.24	174.23
	10/12/95		10.66	172.81
	4/12/96		10.05	173.42
	10/8/96		10.61	172.86
	4/9/97		10.40	173.07
	11/5/97		10.88	172.59
	3/1/00		8.49	174.98
	09/00		U	-
	3/22/01		9.65	173.82
	8/23/01		9.65	173.82
	03/2002		U	-
	10/2002		U	-
	03/2003		IA	-
9/17/03		IA	-	
11/20/08		IA	-	
2/11/09		U	-	
8/25/09		CNL	-	
8/4/10		CNL	-	



**Table 5**  
**Summary of Groundwater Elevation Data**  
**Former Unocal Service Station**  
**20405 Redwood Road, Castro Valley, California**

Well	Date Measured	Casing Elevation (Feet above MSL)	Depth to Groundwater (Feet)	Groundwater Elevation (Feet above MSL)
MW-3	12/89	U	U	-
	08/90		U	-
	01/91		U	-
	04/91		U	-
	07/91		U	-
	10/91		U	-
	01/92		U	-
	4/20/92	183.52	10.34	173.18
	7/9/92		10.84	172.68
	10/8/92	184.03	11.96	172.07
	1/12/93		9.28	174.75
	3/4/93		9.53	174.50
	7/1/93		10.56	173.47
	10/19/93		11.04	172.99
	1/12/94		10.90	173.13
	4/25/94		10.37	173.66
	7/28/94		10.95	173.08
	10/13/94		14.37	169.66
	1/10/95		8.23	175.80
	4/19/95		9.54	174.49
	10/12/95		10.97	173.06
	4/12/96		10.06	173.97
	10/8/96		10.87	173.16
	4/9/97		10.40	173.63
	11/5/97		10.97	173.06
	3/1/00		8.68	175.35
	09/00		U	-
	3/22/01		10.22	173.81
	8/23/01		10.02	174.01
	03/02		U	-
	10/02		U	-
	03/03		U	-
9/17/03	10.00		174.03	
11/20/08	IA		-	
2/11/09	U		-	
8/25/09	CNL		-	
8/4/10	CNL	-		

**Table 5**  
**Summary of Groundwater Elevation Data**  
**Former Unocal Service Station**  
**20405 Redwood Road, Castro Valley, California**

<b>Well</b>	<b>Date Measured</b>	<b>Casing Elevation (Feet above MSL)</b>	<b>Depth to Groundwater (Feet)</b>	<b>Groundwater Elevation (Feet above MSL)</b>
<b>MW-4</b>	12/89	U	U	-
	08/90		U	-
	01/91		U	-
	04/91		U	-
	07/91		U	-
	10/91		U	-
	01/92		U	-
	4/20/92		10.89	-
	7/9/92	184.33	10.65	173.68
	10/8/92	184.61	12.78	171.83
	1/12/93		9.67	174.94
	3/4/93		10.20	174.41
	7/1/93		11.41	173.20
	10/19/93		11.92	172.69
	4/25/94		10.94	173.67
	7/28/94		11.74	172.87
	10/13/94		15.31	169.30
	1/10/95		8.02	176.59
	4/19/95		9.97	174.64
	10/12/95		11.70	172.91
4/12/96		10.33	174.28	
10/8/96		11.65	172.96	
4/9/97		10.93	173.68	
11/5/97		11.82	172.79	

MW-4 abandoned December 1999.

**Table 5**  
**Summary of Groundwater Elevation Data**  
**Former Unocal Service Station**  
**20405 Redwood Road, Castro Valley, California**

<b>Well</b>	<b>Date Measured</b>	<b>Casing Elevation (Feet above MSL)</b>	<b>Depth to Groundwater (Feet)</b>	<b>Groundwater Elevation (Feet above MSL)</b>
<b>MW-5</b>	4/27/92	183.62	11.72	171.90
	7/9/92		12.24	171.38
	10/8/92	183.92	13.24	170.68
	1/12/93		10.30	173.62
	3/4/93		10.53	173.39
	7/1/93		11.85	172.07
	10/19/93		12.32	171.60
	4/25/94		11.58	172.34
	07/94		U	-
	10/13/94		15.71	168.21
	01/95		U	-
	4/19/95		10.41	173.51
	10/12/95		12.12	171.80
	4/12/96		10.85	173.07
	10/8/96		12.00	171.92
	4/9/97		11.40	172.52
	11/5/97		12.19	171.73
	3/1/00		9.45	174.47
	09/00		U	-
	3/22/01		11.04	172.88
	8/23/01		11.06	172.86
	03/02		NS	-
	10/02	NS	-	
	03/03	NS	-	
	9/17/03	11.03	172.89	
	11/20/08	11.80	172.12	
	2/6/09	11.56	172.36	
	8/25/09	11.90	172.02	
	8/4/10	11.61	172.31	

**Table 5**  
**Summary of Groundwater Elevation Data**  
**Former Unocal Service Station**  
**20405 Redwood Road, Castro Valley, California**

<b>Well</b>	<b>Date Measured</b>	<b>Casing Elevation (Feet above MSL)</b>	<b>Depth to Groundwater (Feet)</b>	<b>Groundwater Elevation (Feet above MSL)</b>
<b>MW-6</b>	4/27/92	U	11.90	171.80
	7/9/92	183.70	12.34	171.36
	10/8/92	183.96	13.3	170.66
	1/12/93	183.60	10.59	173.01
	3/4/93		10.86	172.74
	7/1/93		12.00	171.60
	10/19/93		12.48	171.12
	4/25/94		11.86	171.74
	07/94		U	-
	10/13/94		15.87	167.73
	01/95		U	-
	4/19/95		10.70	172.90
	10/12/95		12.32	171.28
	4/12/96		11.09	172.51
	10/8/96		12.19	171.41
	4/9/97		11.70	171.90
	11/5/97		12.33	171.27
	3/1/00		9.73	173.87
	09/00		U	-
	3/22/01		11.01	172.59
	8/23/01		11.21	172.39
	03/02		U	-
	10/02		U	-
03/03		U	-	
9/17/03		11.50	172.10	
11/20/08		12.10	171.50	
2/6/09		11.83	171.77	
8/25/09		Dry	-	
8/4/10		12.85	170.75	

**Table 5**  
**Summary of Groundwater Elevation Data**  
**Former Unocal Service Station**  
**20405 Redwood Road, Castro Valley, California**

Well	Date Measured	Casing Elevation (Feet above MSL)	Depth to Groundwater (Feet)	Groundwater Elevation (Feet above MSL)
MW-7	4/27/92	182.52	10.97	171.55
	7/9/92		11.43	171.09
	10/8/92	182.78	12.40	170.38
	11/30/92		12.00	170.78
	1/12/93		9.51	173.27
	01/93		U	-
	3/4/93		9.88	172.90
	7/1/93		11.07	171.71
	10/19/93		11.55	171.23
	1/12/94	182.42	11.36	171.06
	4/25/94		10.85	171.57
	7/28/94		NS	-
	10/13/94		NS	-
	01/95		U	-
	4/19/95		9.66	172.76
	10/12/95		11.34	171.08
	4/12/96		10.06	172.36
	10/8/96		11.16	171.26
	4/9/97		11.70	170.72
	11/5/97		11.36	171.06
	3/1/00		8.72	173.70
	09/00		U	-
	3/22/01		10.04	172.38
	8/23/01		10.18	172.24
	03/02		U	-
	10/02		IA	-
	03/03	IA	-	
	9/17/03	IA	-	
	11/20/08	11.05	171.37	
	2/6/09	10.76	171.66	
8/25/09	IA	-		
8/4/10	10.76	171.66		

Notes:

IA: Well Inaccessible

CNL: Could not locate well

NS: Well Not Sampled

U: Data Unavailable

-: Unable to calculate elevation

**Table 6**  
**Summary of Groundwater Flow Direction and Gradient Data**  
**Former Unocal Service Station**  
**20405 Redwood Road, Castro Valley, California**

<b>Date</b>	<b>Flow Direction</b>	<b>Gradient (Feet/Foot)</b>
11/1/92	Southeast	0.006
1/27/93	Southeast	0.01
3/4/93	Southeast	0.01
7/1/93	Southeast	0.01
10/19/93	South	0.005
1/12/94	South	0.001
5/13/94	Southwest	0.007
10/13/94	South	0.001
1/31/95	South	0.002
5/17/95	South	0.009
10/30/95	South	0.007
4/12/96	South	0.008
11/5/96	South	0.008
4/9/97	South	0.01
8/23/01	South	0.008
9/17/03	Southeast	0.01
11/20/08	Southeast	0.01
2/5/09	South-southeast	0.01
8/25/09	-	-
8/4/10	East-southeast	0.01

Notes:  
 -: Unable to calculate flow direction

---

## FIGURES

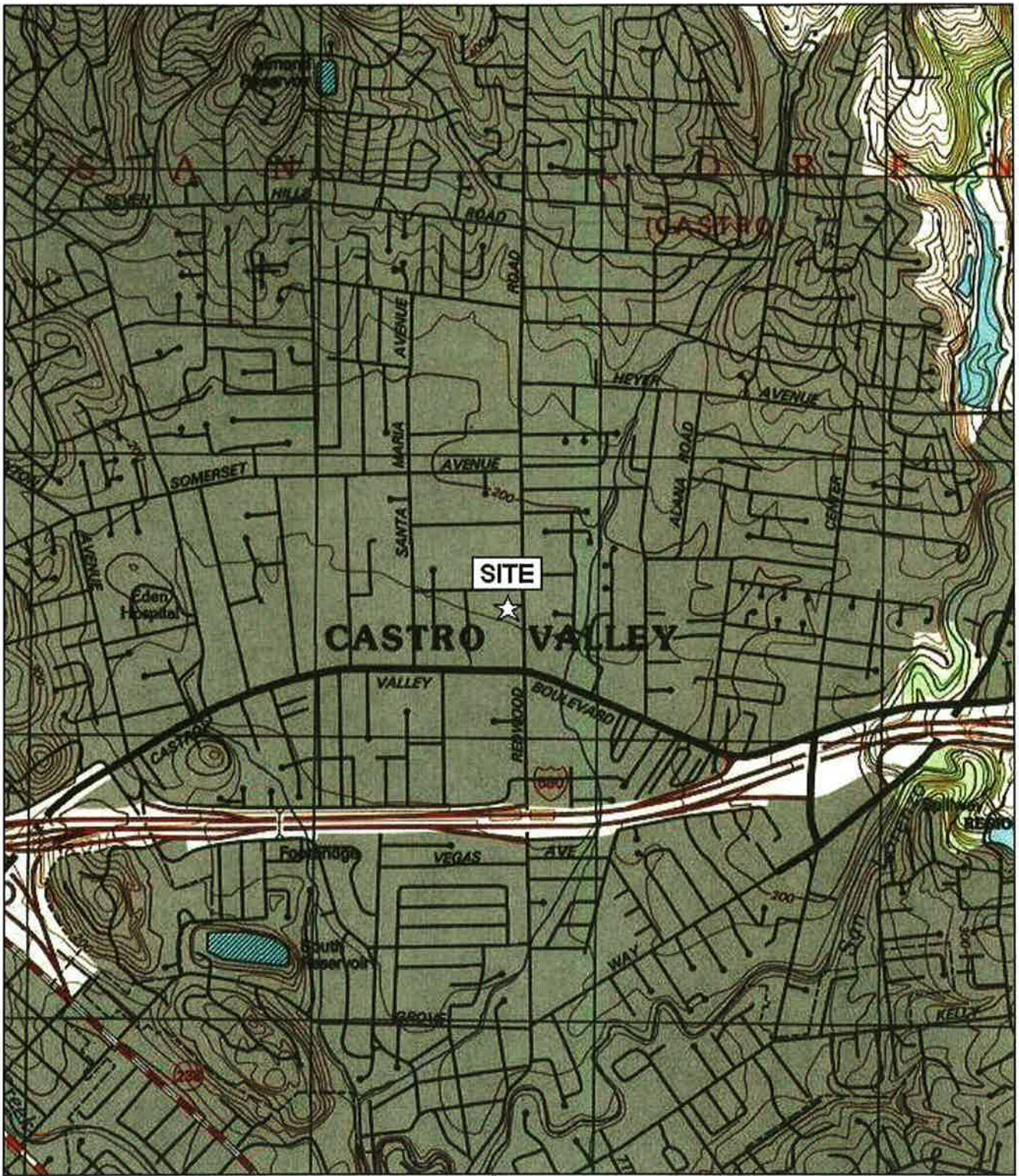

TN  $\star$  /MN  
15°



Map created with TOPO!® ©2003 National Geographic ([www.nationalgeographic.com/topo](http://www.nationalgeographic.com/topo))



**SITE VICINITY**  
FORMER UNOCAL SERVICE STATION  
20405 REDWOOD ROAD  
CASTRO VALLEY, CALIFORNIA

FIGURE 1

PROJECT: E0805401S



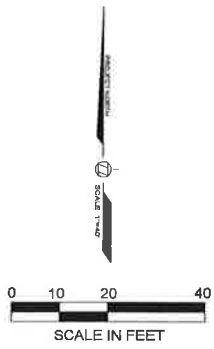
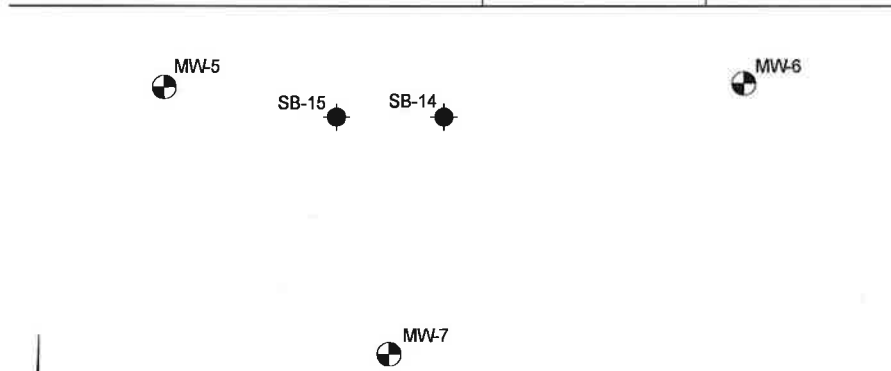
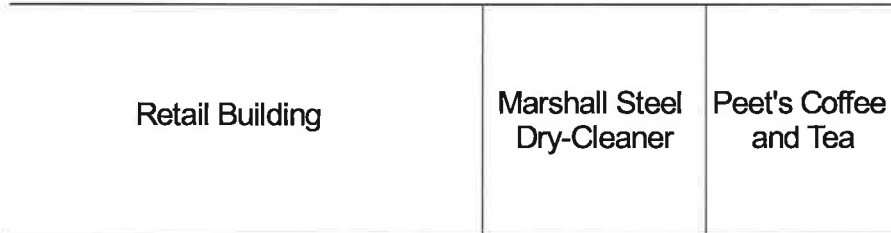
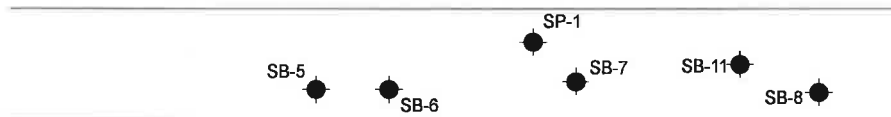
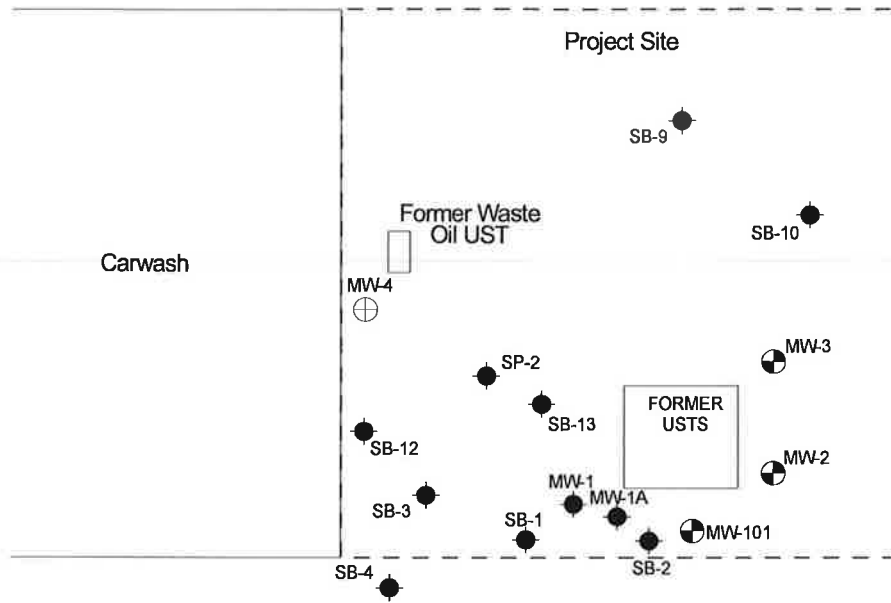

- LEGEND**
- ⊕ Monitoring Well
  - ⊕ Abandoned Monitoring Well
  - Soil Boring



**SITE PLAN**  
FORMER UNOCAL SERVICE STATION  
20405 REDWOOD ROAD  
CASTRO VALLEY, CALIFORNIA

**FIGURE 2**  
PROJECT: E0805401S  
DATE: 1/6/10

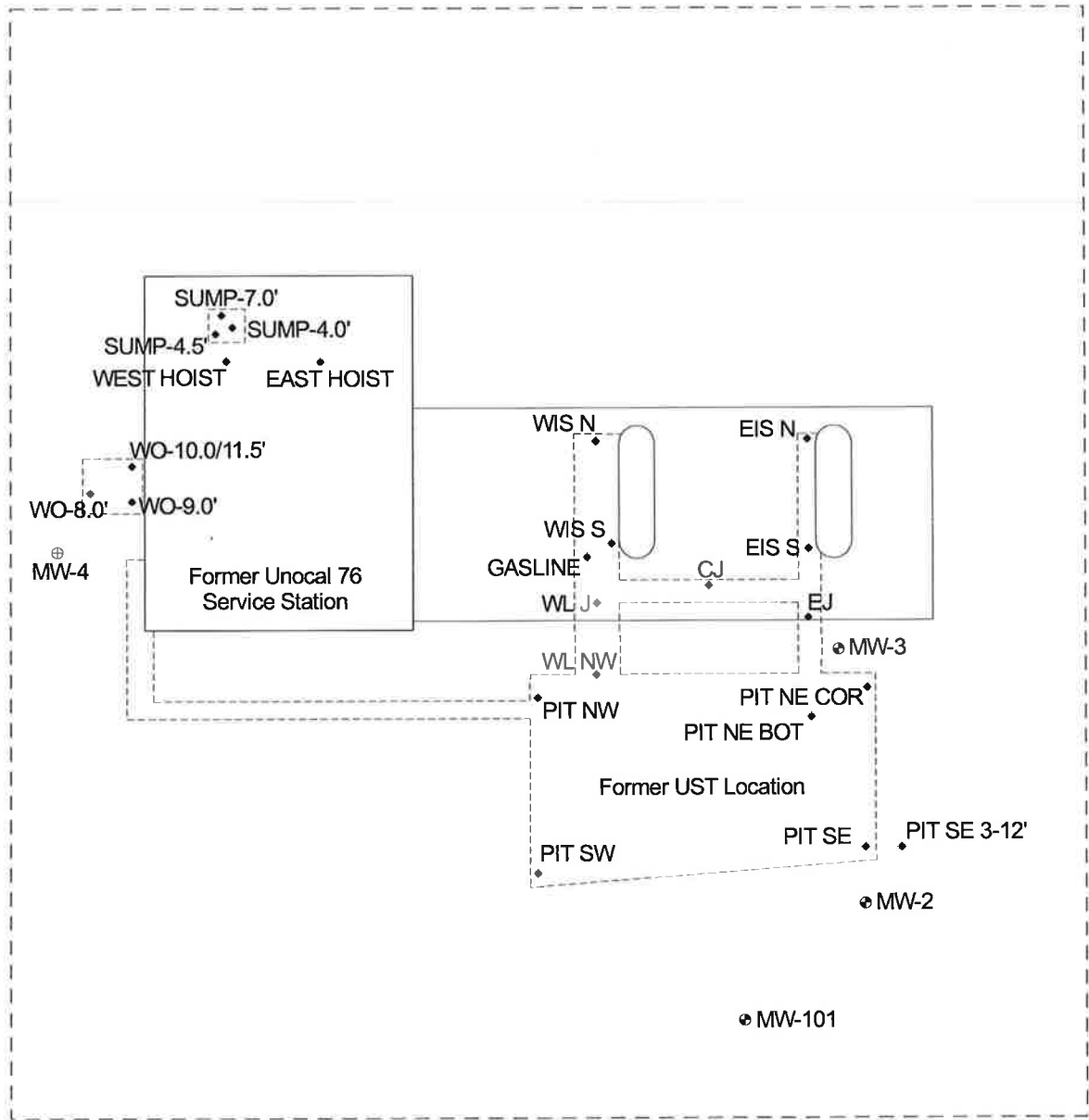

Driveway to Shopping Center ←

Redwood Road

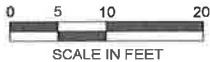

LEGEND	
•	Soil Sample Location
---	Approximate Extent of Excavation
⊕	Monitoring Well Location
⊕	Abandoned Monitoring Well Location



EXTENT OF EXCAVATIONS AND  
EXCAVATION SOIL SAMPLE LOCATIONS  
FORMER UNOCAL SERVICE STATION  
20405 REDWOOD ROAD  
CASTRO VALLEY, CALIFORNIA

FIGURE 3

PROJECT: E0805401S

DATE: 2/12/09

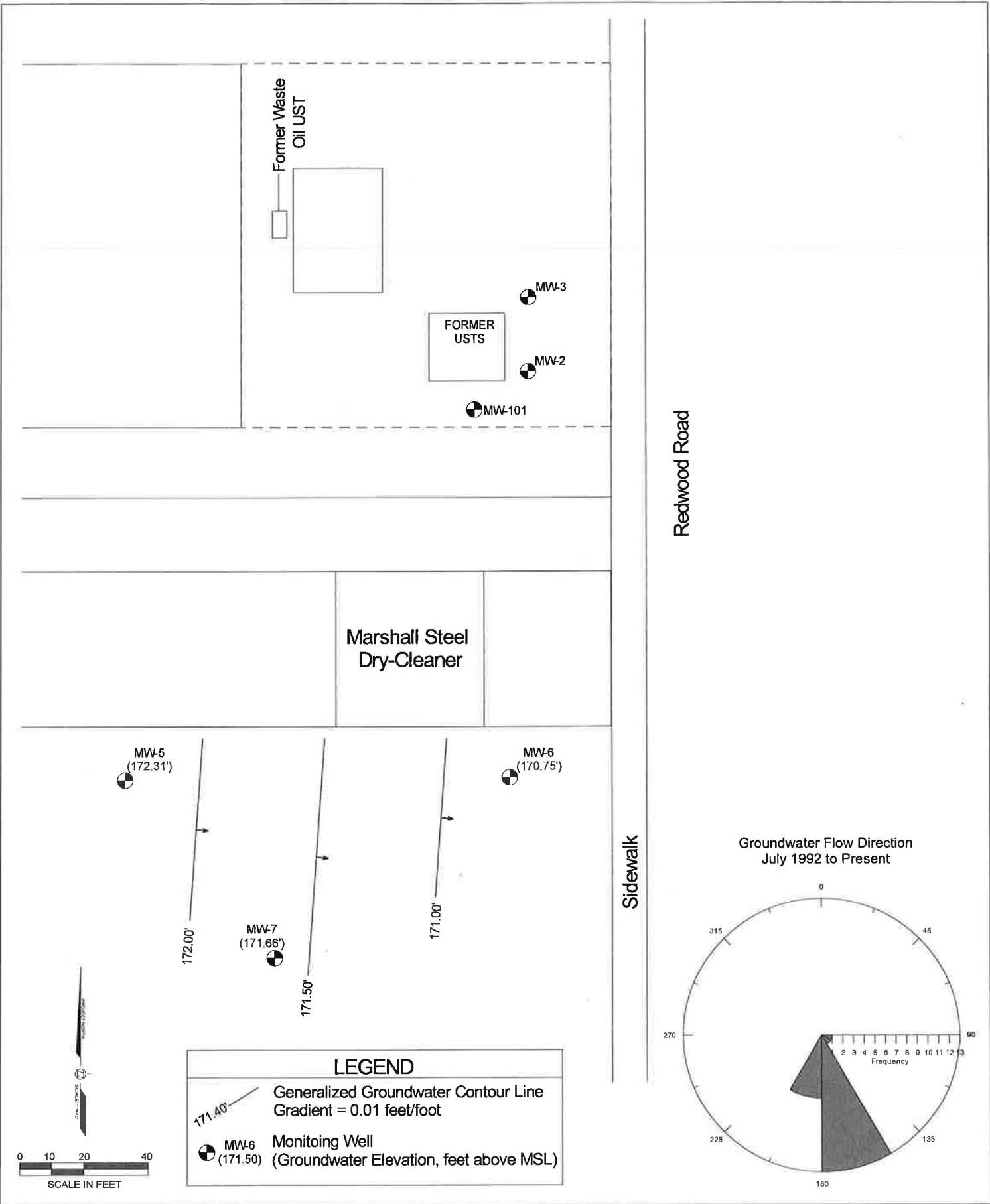

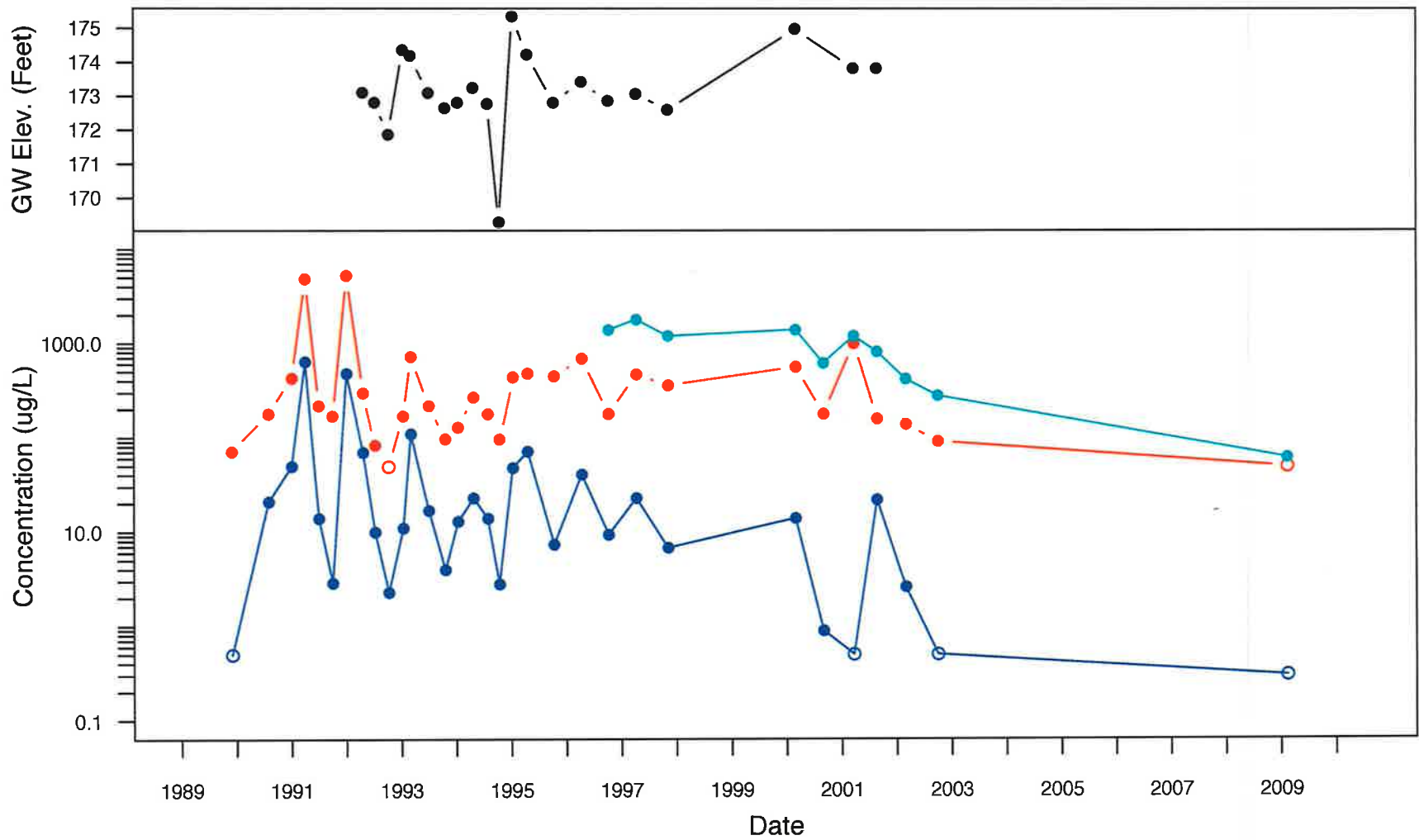

● GW Elevation ● TPHg ● Benzene ● MTBE ○ Not Detected



**MW-2 TIME-SERIES PLOTS**  
 FORMER UNOCAL SERVICE STATION  
 20405 REDWOOD ROAD  
 CASTRO VALLEY, CALIFORNIA

FIGURE 5

PROJECT: E0503102S

DATE: 1/6/11

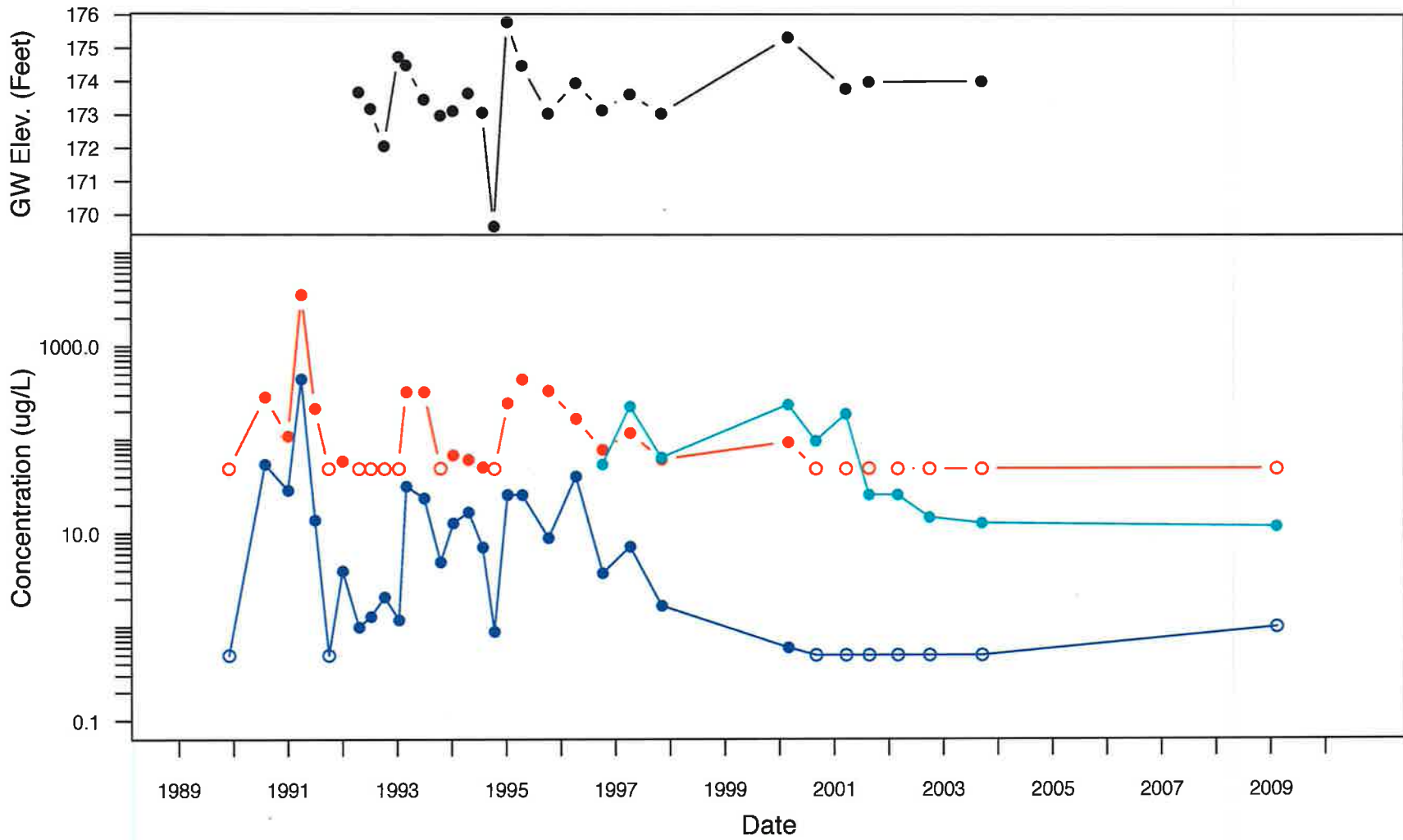

● GW Elevation ● TPHg ● Benzene ● MTBE ○ Not Detected



**MW-3 TIME-SERIES PLOTS**  
 FORMER UNOCAL SERVICE STATION  
 20405 REDWOOD ROAD  
 CASTRO VALLEY, CALIFORNIA

FIGURE 6  
 PROJECT: E0503102S  
 DATE: 1/6/11

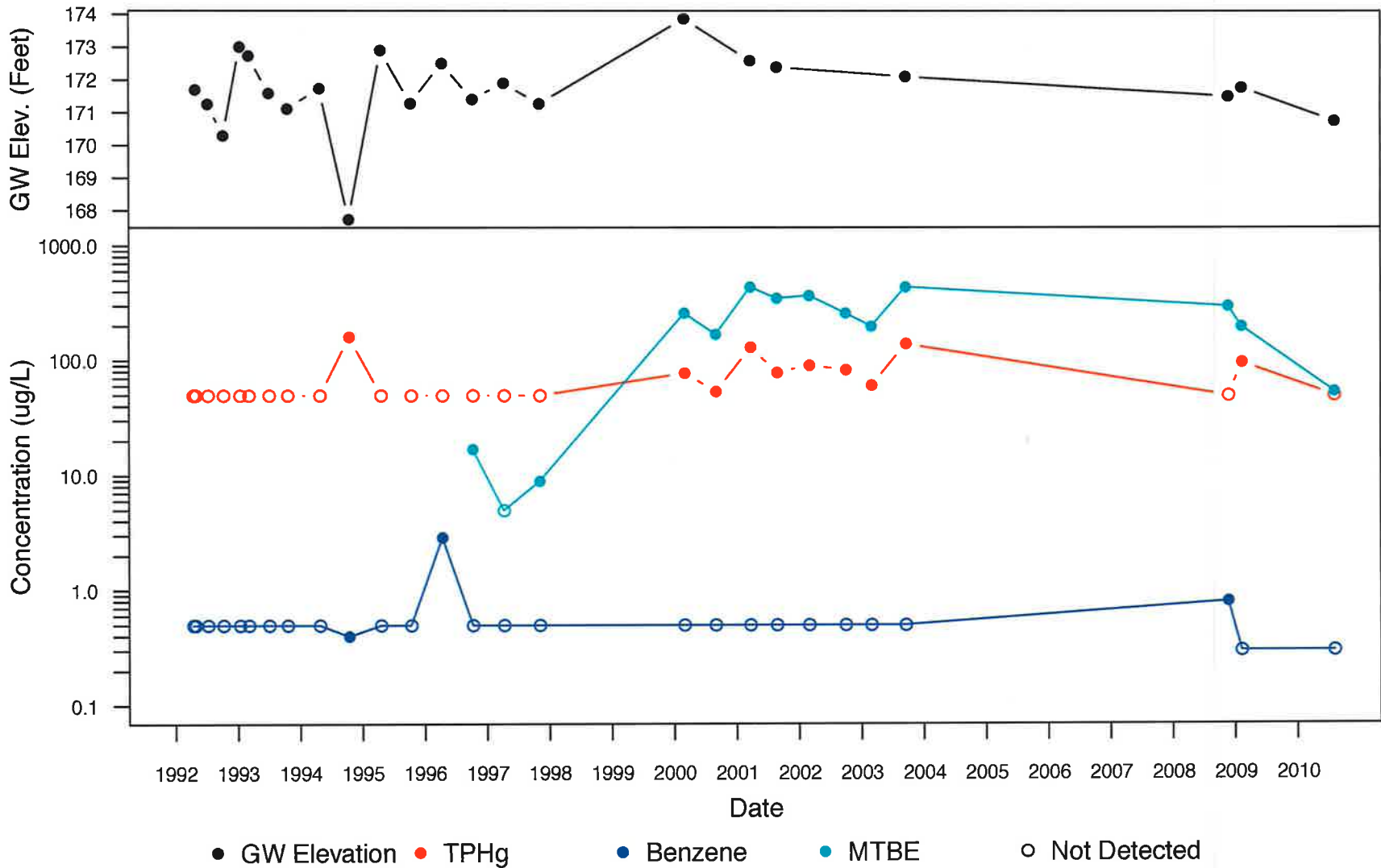

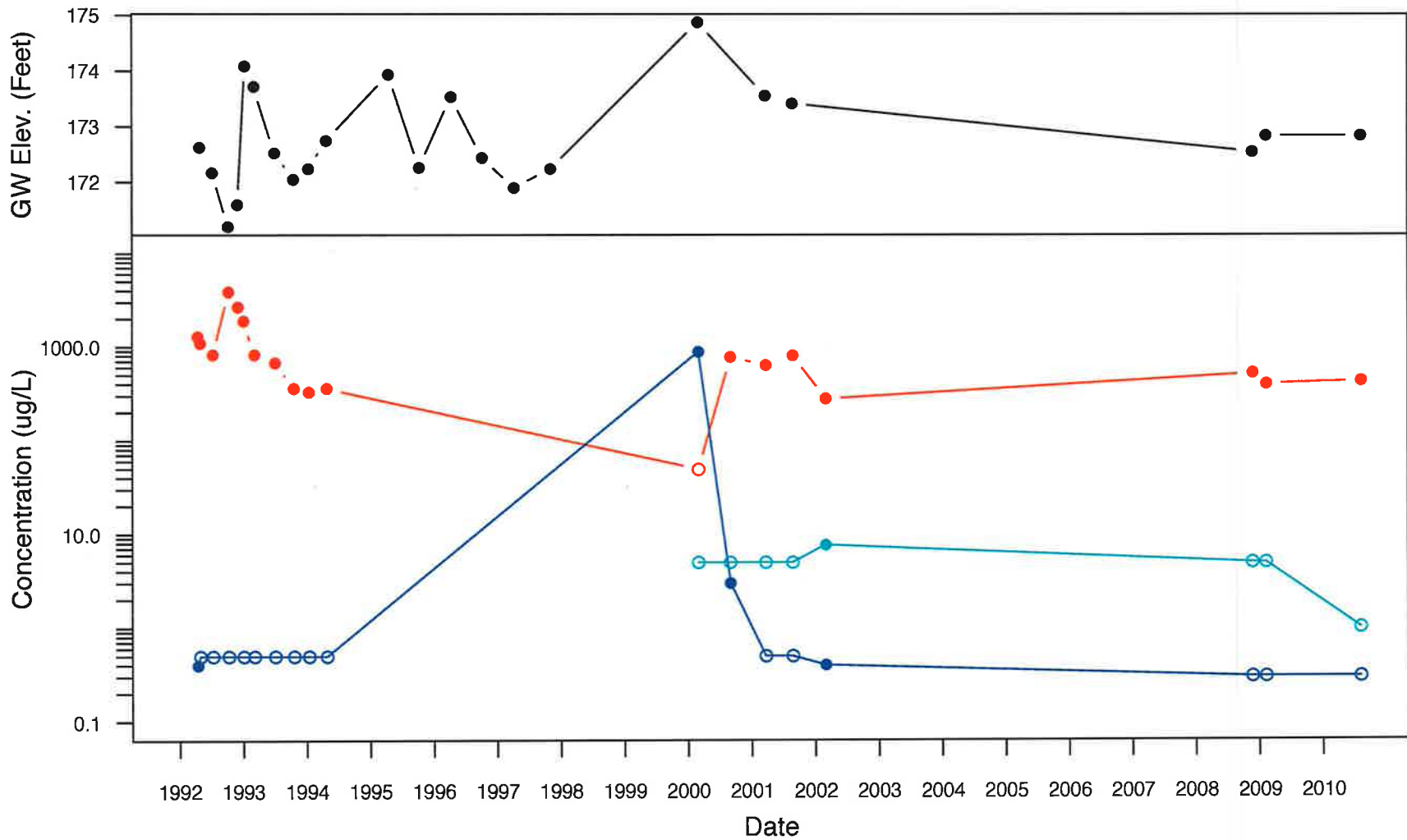

● GW Elevation ● TPHg ● Benzene ● MTBE ○ Not Detected



**MW-7 TIME-SERIES PLOTS**  
 FORMER UNOCAL SERVICE STATION  
 20405 REDWOOD ROAD  
 CASTRO VALLEY, CALIFORNIA

FIGURE 8

PROJECT: E0503102S

DATE: 1/6/10

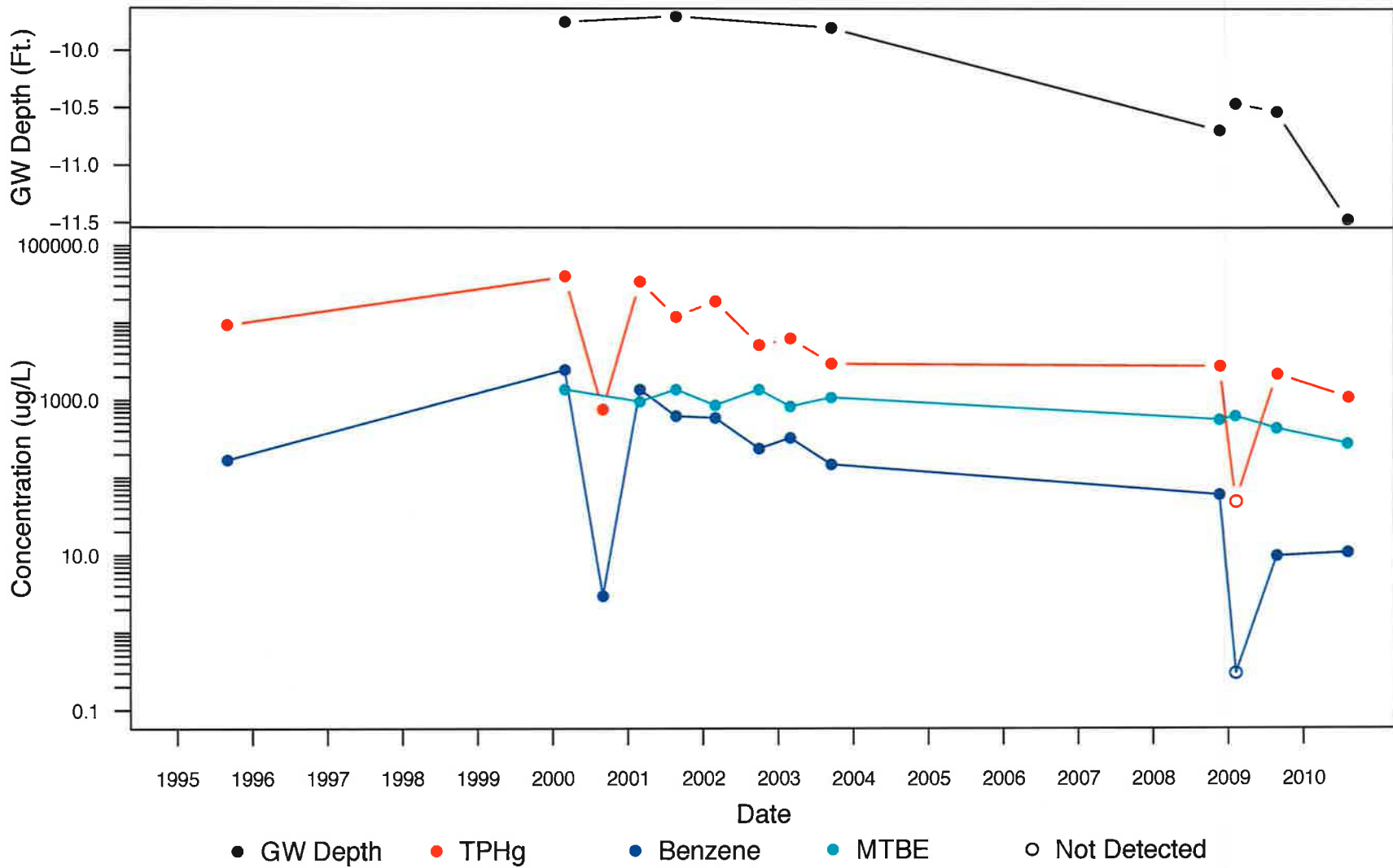



---

## APPENDIX A

# WATER SAMPLE LOG

Project Name: <u>Unocal</u>	Job #: <u>E08054015</u>	Field Personnel: <u>E. Basel</u>
Day: Mon Tu <u>Wed</u> Thur Fri Sat Sun <small>(circle one)</small>	Date: <u>8/4/10</u>	Weather: Clear <u>Partly Cloudy</u> <u>Overcast</u> Rain <small>(circle)</small> Cold <u>Cool</u> Warm Hot Very Hot

Well:	<u>MW-101</u>	Water Level Measurement Technique: (Circle) <u>Electric Sounder</u> Ser # _____ Not Measured
Static Depth to Water-Ft. (A)	<u>11.47</u>	Purge Method: Grundfos Submersible Pump Pneumatic Pump
Total Depth of Casing-Ft. (B)	<u>29.31</u>	(Circle) <u>Electric Pump</u> Hand Bailed
Total Ft. of Water (B-A)	<u>17.84</u>	Other _____
Casing Dia-in.	2" <u>4</u> 6" 8"	Dedicated System: Yes <u>No</u>
Casing Capacity-gal/ft (C)	.163 <u>653</u> 1.46 2.50	Dedicated System: Yes <u>No</u>
Gallons per Casing Volume	(B-A)*C <u>12</u>	pH Calibration: <u>X</u> 4.0 <u>X</u> 7.0 / 10.0 EC Calibration(umhos) <u>X</u> 1413

Time	Gallons Purged	Casing Volumes	PH	EC (umhos)	Temp (EF) (EC)	Turbidity NTU or D.O.mg/l	Remarks (Color, Odor, Turbidity, etc.)
<u>10:05</u>	<u>0</u>	<u>0</u>	<u>---</u>	<u>---</u>	<u>---</u>	<u>---</u>	Started Purge/Opened Sample Port
<u>10:12</u>	<u>12</u>	<u>1</u>	<u>6.41</u>	<u>803</u>	<u>67.5</u>	<u>-</u>	<u>clear, HCl odor</u>
<u>10:19</u>	<u>24</u>	<u>2</u>	<u>6.82</u>	<u>795</u>	<u>68.0</u>	<u>-</u>	<u>" "</u>
<u>10:25</u>	<u>36</u>	<u>3</u>	<u>6.95</u>	<u>788</u>	<u>68.7</u>	<u>-</u>	<u>" "</u>

Chloride	Sulfate	Nitrate	X4.4	Sampled/Stopped
				Other Field Results:

Purge Pump On	<u>10:05</u>	Discharge Measurement: (Circle) <u>Bucket</u> Tank Flowmeter
Purge Pump Off	<u>10:25</u>	Sample Collection Method: <u>X</u> Direct From Discharge Hose
Total Gallons Purged		_____ Teflon Bailer <u>X</u> Disposable Bailer
Purge Rate (gpm)		Ice Chest Coolant <u>X</u> Crushed Ice _____ Blue Ice Ice Chest Temp (EC) _____

Sample Time	Analyses	Amount/Container Used	Sample Description
<u>10:32</u>		<u>4x 40ml vials</u> <u>1x 250 ml amber</u>	<u>H2SO4</u>

Well Vault Type:	<u>flush</u>	Floating Product: ___ Yes ___ No ___ NA
Lock Number/Type:		Thickness: _____
Drums Filled/Used:	<u>yes</u>	Description: _____

Notes: \_\_\_\_\_

\_\_\_\_\_

\_\_\_\_\_

\_\_\_\_\_

# WATER SAMPLE LOG

Project Name: <u>Unocal</u>	Job #: <u>E0805405</u>	Field Personnel: <u>E. Basel</u>
Day: Mon Tu <u>Wed</u> Thur Fri Sat Sun <small>(circle one)</small>	Date: <u>8/4/10</u>	Weather: Clear <u>Partly Cloudy</u> Overcast Rain <small>(circle)</small> Cold Cool <u>Warm</u> Hot Very Hot

Well: <u>MW-5</u>	Water Level Measurement Technique: (Circle) <u>Electric Sounder</u> Ser # _____ Not Measured
Static Depth to Water-Ft. (A) <u>11.61</u>	Purge Method: Grundfos Submersible Pump Pneumatic Pump
Total Depth of Casing-Ft. (B) <u>34.3</u>	(Circle) Electric Pump <u>Hand Bailed</u>
Total Ft. of Water (B-A) <u>22.69</u>	Other _____
Casing Dia-in. <u>2</u> 4" 6" 8"	Dedicated System: Yes <u>No</u>
Casing Capacity-gal/ft (C) <u>163</u> .653 1.46 2.50	Dedicated System: _____ Yes <u>No</u>
Gallons per Casing Volume (B-A)*C <u>3.75</u>	pH Calibration: <u>X</u> 4.0 <u>X</u> 7.0 10.0 EC Calibration(µmhos) <u>1413</u>

Time	Gallons Purged	Casing Volumes	PH	EC (µmhos)	Temp (EF) (EC)	Turbidity NTU or D.O.mg/l	Remarks (Color, Odor, Turbidity, etc.)
	0	0	---	---	---	---	Started Purge/Opened Sample Port
12:26	3.75	1	6.87	561	70.7	—	clear odor less
12:42	7.5	2	6.87	553	68.9	—	v n
12:56	11.25	3	6.91	547	70.2	—	n - n

Chloride	Sulfate	Nitrate	X4.4	Sampled/Stopped	Other Field Results:
----------	---------	---------	------	-----------------	----------------------

Purge Pump On	—	Discharge Measurement: (Circle) <u>Bucket</u> Tank Flowmeter
Purge Pump Off	—	Sample Collection Method: _____ Direct From Discharge Hose
Total Gallons Purged	—	_____ Teflon Bailer <u>X</u> Disposable Bailer
Purge Rate (gpm)	—	Ice Chest Coolant <u>X</u> Crushed Ice _____ Blue Ice Ice Chest Temp (EC) _____

Sample Time	Analyses	Amount/Container Used	Sample Description
13:05		4x 40ml vials 1x 250 amber	H <sub>2</sub> SO <sub>4</sub>

Well Vault Type: <u>flush</u>	Lock Number/Type: <u>master lock</u>	Floating Product: ___ Yes ___ No ___ NA
Drums Filled/Used: <u>yes</u>		Thickness: _____
		Description: _____

Notes: \_\_\_\_\_

\_\_\_\_\_

\_\_\_\_\_

\_\_\_\_\_

# WATER SAMPLE LOG

Project Name: <u>Unocal</u>	Job #: <u>E08054015</u>	Field Personnel: <u>E. Basel</u>
Day: Mon Tu <u>Wed</u> Thur Fri Sat Sun <small>(circle one)</small>	Date: <u>8/4/10</u>	Weather: Clear <u>Partly Cloudy</u> <u>Overcast</u> Rain <small>(circle)</small> Cold <u>Cool</u> Warm Hot Very Hot

Well:	<u>MW-6</u>	Water Level Measurement Technique: (Circle) <u>Electric Sounder</u> Ser # _____ Not Measured
Static Depth to Water-Ft. (A)	<u>12.85</u>	Purge Method: Grundfos Submersible Pump Pneumatic Pump (Circle) <u>Electric Pump</u> Hand Bailed Other _____ Dedicated System: Yes <u>No</u>
Total Depth of Casing-Ft. (B)	<u>26.54</u>	
Total Ft. of Water (B-A)	<u>13.69</u>	
Casing Dia-in.	<u>2</u> 4" 6" 8"	
Casing Capacity-gal/ft (C)	<u>163</u> .653 1.46 2.50	Dedicated System: Yes <u>No</u>
Gallons per Casing Volume	(B-A)*C <u>2.23</u>	pH Calibration: <u>X</u> 4.0 <u>X</u> 7.0 10.0 EC Calibration(µmhos) _____

Time	Gallons Purged	Casing Volumes	PH	EC (µmhos)	Temp (EF) (EC)	Turbidity NTU or D.O.mg/l	Remarks (Color, Odor, Turbidity, etc.)
<u>8:58</u>	<u>0</u>	<u>0</u>	<u>---</u>	<u>---</u>	<u>---</u>	<u>---</u>	Started Purge/Opened Sample Port
<u>9:00</u>	<u>2.25</u>	<u>1</u>	<u>5.85</u>	<u>658</u>	<u>67.1</u>	<u>---</u>	<u>clear odorless</u>
<u>9:01</u>	<u>4.5</u>	<u>2</u>	<u>5.97</u>	<u>663</u>	<u>68.4</u>	<u>---</u>	<u>" "</u>
<u>9:02</u>	<u>6.75</u>	<u>3</u>	<u>6.19</u>	<u>674</u>	<u>68.5</u>	<u>---</u>	<u>" "</u>

Chloride	Sulfate	Nitrate	X4.4	Sampled/Stopped
				Other Field Results:

Purge Pump On	<u>8:58</u>	Discharge Measurement: (Circle) <u>Bucket</u> Tank Flowmeter
Purge Pump Off	<u>9:02</u>	Sample Collection Method: <u>X</u> Direct From Discharge Hose Teflon Bailer <u>X</u> Disposable Bailer
Total Gallons Purged	<u>6.75</u>	
Purge Rate (gpm)		Ice Chest Coolant <u>X</u> Crushed Ice Blue Ice Ice Chest Temp (EC) _____

Sample Time	Analyses	Amount/Container Used	Sample Description
<u>9:10</u>		<u>4 vials 40ml</u> <u>1 x 250 amber</u>	<u>H2SO4</u>

Well Vault Type:	<u>flush</u>	Floating Product: ___ Yes ___ No ___ NA
Lock Number/Type:	<u>master lock</u>	Thickness: _____
Drums Filled/Used:	<u>yes</u>	Description: _____

Notes: \_\_\_\_\_

\_\_\_\_\_

\_\_\_\_\_

\_\_\_\_\_

# WATER SAMPLE LOG

Project Name: <u>Unocal</u>	Job #: <u>E08054015</u>	Field Personnel: <u>E. Basel</u>
Day: Mon Tu <u>Wed</u> Thur Fri Sat Sun <small>(circle one)</small>	Date: <u>8/4/10</u>	Weather: Clear <u>Partly Cloudy</u> Overcast Rain <small>(circle)</small> Cold Cool <u>Warm</u> Hot Very Hot

Well: <u>MW-7</u>	Water Level Measurement Technique: (Circle) <u>Electric Sounder</u> Ser # _____ Not Measured
Static Depth to Water-Ft. (A) <u>10.76</u>	Purge Method: Grundfos Submersible Pump Pneumatic Pump (Circle) <u>Electric Pump</u> Hand Bailed Other _____ Dedicated System: Yes <input checked="" type="checkbox"/> No
Total Depth of Casing-Ft. (B) <u>27.07</u>	
Total Ft. of Water (B-A) <u>16.33</u>	
Casing Dia-in. <u>4" 6" 8"</u>	Dedicated System: Yes <input checked="" type="checkbox"/> No
Casing Capacity-gal/ft (C) <u>163</u> .653 1.46 2.50	pH Calibration: <u>X</u> 4.0 <u>X</u> 7.0 10.0 EC Calibration(μmhos) <u>1413</u>
Gallons per Casing Volume (B-A)*C	

Time	Gallons Purged	Casing Volumes	PH	EC (μmhos)	Temp (EF) (EC)	Turbidity NTU or D.O.mg/l	Remarks (Color, Odor, Turbidity, etc.)
<u>13:30</u>	<u>0</u>	<u>0</u>	<u>---</u>	<u>---</u>	<u>---</u>	<u>---</u>	Started Purge/Opened Sample Port
<u>13:31</u>	<u>2.75</u>	<u>1</u>	<u>7.24</u>	<u>617</u>	<u>73.9</u>	<u>-</u>	<u>clear for sediment colorless</u>
<u>13:32</u>	<u>5.5</u>	<u>2</u>	<u>7.04</u>	<u>640</u>	<u>71.4</u>	<u>-</u>	<u>2</u>
<u>13:34</u>	<u>8.25</u>	<u>3</u>	<u>7.02</u>	<u>631</u>	<u>70.9</u>	<u>-</u>	<u>2</u>

Chloride	Sulfate	Nitrate	X4.4	Sampled/Stopped
				Other Field Results:

Purge Pump On <u>13:30</u>	Discharge Measurement: (Circle) <u>Bucket</u> Tank Flowmeter
Purge Pump Off <u>13:34</u>	Sample Collection Method: <input checked="" type="checkbox"/> Direct From Discharge Hose <input type="checkbox"/> Teflon Bailer <input checked="" type="checkbox"/> Disposable Bailer
Total Gallons Purged <u>8.25</u>	
Purge Rate (gpm)	Ice Chest Coolant <input checked="" type="checkbox"/> Crushed Ice <input type="checkbox"/> Blue Ice Ice Chest Temp (EC) _____

Sample Time	Analyses	Amount/Container Used	Sample Description
<u>13:36</u>		<u>4x 4ml vials</u>	
		<u>1x 250ml amber</u>	<u>H2SO4</u>

Well Vault Type: <u>Flush</u>	Floating Product: <input type="checkbox"/> Yes <input type="checkbox"/> No <input type="checkbox"/> NA
Lock Number/Type: <u>Master Key</u>	Thickness: _____
Drums Filled/Used: <u>Yes</u>	Description: _____

Notes: \_\_\_\_\_

\_\_\_\_\_

\_\_\_\_\_

\_\_\_\_\_

Jeff Yeazell  
BSK Associates - Sacramento  
3140 Gold Camp Drive Suite 160  
Rancho Cordova, CA 95670

Dear Jeff Yeazell,

Thank you for selecting BSK Analytical Laboratories for your analytical testing needs. We have prepared this report in response to your request for analytical services. Enclosed are the results of analyses for samples received by the laboratory on 08/12/2010 08:00.

If additional clarification of any information is required, please contact your Client Services Representative, Julio Morales at (800) 877-8310 or (559) 497-2888.

BSK ANALYTICAL LABORATORIES



---

Julio Morales  
Client Service Representative

---

## APPENDIX B

**Case Narrative**

**Work Order Information**

**Client Name:** BSK Associates - Sacramento  
**Client Code:** BSKAs9293  
**Work Order:** A0H1054  
**Project:** Unocal Castro Valley  
**Client Project:** E0805401S

**Submitted by:** Erin Basel  
**Shipped by:** ONTRAC  
**COC Number:**  
**TAT:** 10  
**PO #:**

**Sample Receipt Conditions**

**Cooler:** Default Cooler      **Temp. °C:** 0  
Containers Intact  
COC/Labels Agree  
Received On Wet Ice  
Packing Material - Bubble Wrap  
Packing Material - Foam  
Sample(s) were received in temperature range.  
Initial receipt at BSK-SAC

**Report Manager**

Jeff Yeazell  
Jeff Yeazell

**Report Format**

FAL Final MultiOrder.rpt  
FAL Final MultiOrder.rpt



## Certificate of Analysis

Jeff Yeazell  
BSK Associates - Sacramento  
3140 Gold Camp Drive Suite 160  
Rancho Cordova, CA 95670

Report Issue Date: 8/31/2010 14:11  
Received Date: 08/12/2010  
Received Time: 08:00

Lab Sample ID: A0H1054-01  
Sample Date: 08/04/2010 09:10  
Sample Type: Grab

Client Project: E0805401S  
Sampled by:  
Matrix: Water

Sample Description: MW-6

### Organics

Analyte	Method	Result	RL	Units	Dil.	Batch	Prepared	Analyzed	Qualifiers
<b>BTEX and TPH-Gasoline by EPA 8015B/8021B</b>									
*Benzene	8015/8021	ND	0.30	ug/L	1	A007269	08/16/10	08/16/10	
*Ethylbenzene	8015/8021	ND	0.30	ug/L	1	A007269	08/16/10	08/16/10	
*Toluene	8015/8021	ND	0.30	ug/L	1	A007269	08/16/10	08/16/10	
*TPH as Gasoline	8015/8021	ND	50	ug/L	1	A007269	08/16/10	08/16/10	
*Xylene (Total)	8015/8021	ND	0.30	ug/L	1	A007269	08/16/10	08/16/10	
<b>VOCs by EPA 8260B</b>									
Sample Qualifiers: SC07									
*1,2-Dibromoethane (EDB)	EPA 8260B	ND	1.0	ug/L	1	A007267	08/13/10	08/13/10	
*1,2-Dichloroethane	EPA 8260B	ND	1.0	ug/L	1	A007267	08/13/10	08/13/10	
*Di-isopropyl ether (DIPE)	EPA 8260B	ND	1.0	ug/L	1	A007267	08/13/10	08/13/10	
*Ethyl tert-Butyl Ether (ETBE)	EPA 8260B	ND	1.0	ug/L	1	A007267	08/13/10	08/13/10	
*Methyl-t-butyl ether	EPA 8260B	54	1.0	ug/L	1	A007267	08/13/10	08/13/10	
*tert-Amyl Methyl Ether (TAME)	EPA 8260B	ND	1.0	ug/L	1	A007267	08/13/10	08/13/10	
*tert-Butyl alcohol (TBA)	EPA 8260B	ND	50	ug/L	1	A007267	08/13/10	08/13/10	
<b>Total Petroleum Hydrocarbons by EPA 8015B</b>									
*TPH as Diesel	8015B	ND	100	ug/L	1	A007279	08/16/10	08/17/10	

	Method	Result	
Surrogate: Fluorobenzene	8015/8021	100 %	Acceptable range: 70-130 %
Surrogate: Toluene-d8	EPA 8260B	104 %	Acceptable range: 80-130 %
Surrogate: Tetracosane	8015B	77.4 %	Acceptable range: 45-189 %

Lab Sample ID: A0H1054-02  
Sample Date: 08/04/2010 10:32  
Sample Type: Grab

Client Project: E0805401S  
Sampled by:  
Matrix: Water

Sample Description: MW-101

### Organics

Analyte	Method	Result	RL	Units	Dil.	Batch	Prepared	Analyzed	Qualifiers
<b>BTEX and TPH-Gasoline by EPA 8015B/8021B</b>									
*Benzene	8015/8021	11	0.30	ug/L	1	A007269	08/16/10	08/16/10	
*Ethylbenzene	8015/8021	12	0.30	ug/L	1	A007269	08/16/10	08/16/10	
*Toluene	8015/8021	ND	0.30	ug/L	1	A007269	08/16/10	08/16/10	

## Certificate of Analysis

Jeff Yeazell  
BSK Associates - Sacramento  
3140 Gold Camp Drive Suite 160  
Rancho Cordova, CA 95670

Report Issue Date: 8/31/2010 14:11  
Received Date: 08/12/2010  
Received Time: 08:00

Lab Sample ID: A0H1054-02  
Sample Date: 08/04/2010 10:32  
Sample Type: Grab

Client Project: E0805401S  
Sampled by:  
Matrix: Water

Sample Description: MW-101

### Organics

Analyte	Method	Result	RL	Units	Dil.	Batch	Prepared	Analyzed	Qualifiers
*TPH as Gasoline	8015/8021	1100	50	ug/L	1	A007269	08/16/10	08/16/10	
*Xylene (Total)	8015/8021	4.8	0.30	ug/L	1	A007269	08/16/10	08/16/10	
<b>VOCs by EPA 8260B</b>						<i>Sample Qualifiers: SC07</i>			
*1,2-Dibromoethane (EDB)	EPA 8260B	ND	1.0	ug/L	1	A007267	08/13/10	08/13/10	
*1,2-Dichloroethane	EPA 8260B	ND	1.0	ug/L	1	A007267	08/13/10	08/13/10	
*Di-isopropyl ether (DIPE)	EPA 8260B	ND	1.0	ug/L	1	A007267	08/13/10	08/13/10	
*Ethyl tert-Butyl Ether (ETBE)	EPA 8260B	ND	1.0	ug/L	1	A007267	08/13/10	08/13/10	
*Methyl-t-butyl ether	EPA 8260B	280	20	ug/L	20	A007267	08/13/10	08/13/10	
*tert-Amyl Methyl Ether (TAME)	EPA 8260B	ND	1.0	ug/L	1	A007267	08/13/10	08/13/10	
*tert-Butyl alcohol (TBA)	EPA 8260B	ND	50	ug/L	1	A007267	08/13/10	08/13/10	
<b>Total Petroleum Hydrocarbons by EPA 8015B</b>									
*TPH as Diesel	8015B	1300	100	ug/L	1	A007279	08/16/10	08/17/10	

	<u>Method</u>	<u>Result</u>	
Surrogate: Fluorobenzene	8015/8021	110 %	Acceptable range: 70-130 %
Surrogate: Toluene-d8	EPA 8260B	102 %	Acceptable range: 80-130 %
Surrogate: Tetracosane	8015B	112 %	Acceptable range: 45-189 %

Lab Sample ID: A0H1054-03  
Sample Date: 08/04/2010 13:05  
Sample Type: Grab

Client Project: E0805401S  
Sampled by:  
Matrix: Water

Sample Description: MW-5

### Organics

Analyte	Method	Result	RL	Units	Dil.	Batch	Prepared	Analyzed	Qualifiers
<b>BTEX and TPH-Gasoline by EPA 8015B/8021B</b>									
*Benzene	8015/8021	ND	0.30	ug/L	1	A007269	08/16/10	08/16/10	
*Ethylbenzene	8015/8021	ND	0.30	ug/L	1	A007269	08/16/10	08/16/10	
*Toluene	8015/8021	ND	0.30	ug/L	1	A007269	08/16/10	08/16/10	
*TPH as Gasoline	8015/8021	ND	50	ug/L	1	A007269	08/16/10	08/16/10	
*Xylene (Total)	8015/8021	ND	0.30	ug/L	1	A007269	08/16/10	08/16/10	
<b>VOCs by EPA 8260B</b>						<i>Sample Qualifiers: SC07</i>			
*1,2-Dibromoethane (EDB)	EPA 8260B	ND	1.0	ug/L	1	A007267	08/13/10	08/13/10	

## Certificate of Analysis

Jeff Yeazell  
BSK Associates - Sacramento  
3140 Gold Camp Drive Suite 160  
Rancho Cordova, CA 95670

Report Issue Date: 8/31/2010 14:11  
Received Date: 08/12/2010  
Received Time: 08:00

Lab Sample ID: A0H1054-03  
Sample Date: 08/04/2010 13:05  
Sample Type: Grab

Client Project: E0805401S  
Sampled by:  
Matrix: Water

Sample Description: MW-5

### Organics

Analyte	Method	Result	RL	Units	Dil.	Batch	Prepared	Analyzed	Qualifiers
*1,2-Dichloroethane	EPA 8260B	ND	1.0	ug/L	1	A007267	08/13/10	08/13/10	
*Di-isopropyl ether (DIPE)	EPA 8260B	ND	1.0	ug/L	1	A007267	08/13/10	08/13/10	
*Ethyl tert-Butyl Ether (ETBE)	EPA 8260B	ND	1.0	ug/L	1	A007267	08/13/10	08/13/10	
*Methyl-t-butyl ether	EPA 8260B	ND	1.0	ug/L	1	A007267	08/13/10	08/13/10	
*tert-Amyl Methyl Ether (TAME)	EPA 8260B	ND	1.0	ug/L	1	A007267	08/13/10	08/13/10	
*tert-Butyl alcohol (TBA)	EPA 8260B	ND	50	ug/L	1	A007267	08/13/10	08/13/10	
<b>Total Petroleum Hydrocarbons by EPA 8015B</b>									
*TPH as Diesel	8015B	ND	100	ug/L	1	A007279	08/16/10	08/17/10	

	Method	Result	
Surrogate: Fluorobenzene	8015/8021	102 %	Acceptable range: 70-130 %
Surrogate: Toluene-d8	EPA 8260B	102 %	Acceptable range: 80-130 %
Surrogate: Tetracosane	8015B	107 %	Acceptable range: 45-189 %

Lab Sample ID: A0H1054-04  
Sample Date: 08/04/2010 13:36  
Sample Type: Grab

Client Project: E0805401S  
Sampled by:  
Matrix: Water

Sample Description: MW-7

### Organics

Analyte	Method	Result	RL	Units	Dil.	Batch	Prepared	Analyzed	Qualifiers
<b>BTEX and TPH-Gasoline by EPA 8015B/8021B</b>									
*Benzene	8015/8021	ND	0.30	ug/L	1	A007269	08/16/10	08/16/10	
*Ethylbenzene	8015/8021	ND	0.30	ug/L	1	A007269	08/16/10	08/16/10	
*Toluene	8015/8021	ND	0.30	ug/L	1	A007269	08/16/10	08/16/10	
*TPH as Gasoline	8015/8021	430	50	ug/L	1	A007269	08/16/10	08/16/10	
*Xylene (Total)	8015/8021	ND	0.30	ug/L	1	A007269	08/16/10	08/16/10	
<b>VOCs by EPA 8260B</b>									
Sample Qualifiers: SC07									
*1,2-Dibromoethane (EDB)	EPA 8260B	ND	1.0	ug/L	1	A007267	08/13/10	08/13/10	
*1,2-Dichloroethane	EPA 8260B	ND	1.0	ug/L	1	A007267	08/13/10	08/13/10	
*Di-isopropyl ether (DIPE)	EPA 8260B	ND	1.0	ug/L	1	A007267	08/13/10	08/13/10	
*Ethyl tert-Butyl Ether (ETBE)	EPA 8260B	ND	1.0	ug/L	1	A007267	08/13/10	08/13/10	
*Methyl-t-butyl ether	EPA 8260B	ND	1.0	ug/L	1	A007267	08/13/10	08/13/10	
*tert-Amyl Methyl Ether (TAME)	EPA 8260B	ND	1.0	ug/L	1	A007267	08/13/10	08/13/10	

A0H1054 FINAL 08312010 1411

## Certificate of Analysis

Jeff Yeazell  
BSK Associates - Sacramento  
3140 Gold Camp Drive Suite 160  
Rancho Cordova, CA 95670

Report Issue Date: 8/31/2010 14:11  
Received Date: 08/12/2010  
Received Time: 08:00

Lab Sample ID: A0H1054-04  
Sample Date: 08/04/2010 13:36  
Sample Type: Grab

Client Project: E0805401S  
Sampled by:  
Matrix: Water

Sample Description: MW-7

### Organics

Analyte	Method	Result	RL	Units	Dil.	Batch	Prepared	Analyzed	Qualifiers
*tert-Butyl alcohol (TBA)	EPA 8260B	ND	50	ug/L	1	A007267	08/13/10	08/13/10	
<b><u>Total Petroleum Hydrocarbons by EPA 8015B</u></b>									
*TPH as Diesel	8015B	ND	100	ug/L	1	A007279	08/16/10	08/17/10	

	<u>Method</u>	<u>Result</u>	
Surrogate: Fluorobenzene	8015/8021	101 %	Acceptable range: 70-130 %
Surrogate: Toluene-d8	EPA 8260B	102 %	Acceptable range: 80-130 %
Surrogate: Tetracosane	8015B	97.5 %	Acceptable range: 45-189 %

## Organics Quality Control Report

Analyte	Result	RL	Units	Spike Level	Source Result	%REC	Limit	RPD	Limit	Qualifiers
---------	--------	----	-------	-------------	---------------	------	-------	-----	-------	------------

Batch: A007267

Analyst: AMN

Prepared & Analyzed: 8/13/2010

**Blank (A007267-BLK1) EPA 8260B - Quality Control**

1,2-Dibromoethane (EDB)	ND	1.0	ug/L							
1,2-Dichloroethane	ND	1.0	ug/L							
Di-isopropyl ether (DIPE)	ND	1.0	ug/L							
Ethyl tert-Butyl Ether (ETBE)	ND	1.0	ug/L							
Methyl-t-butyl ether	ND	1.0	ug/L							
tert-Amyl Methyl Ether (TAME)	ND	1.0	ug/L							
tert-Butyl alcohol (TBA)	ND	50	ug/L							

Surrogate: Toluene-d8      13      12      102      80-130

**Blank Spike (A007267-BS1) EPA 8260B - Quality Control**

1,2-Dibromoethane (EDB)	14	1.0	ug/L	12	114	70-130				
1,2-Dichloroethane	17	1.0	ug/L	12	133	70-130				BS01 High
Di-isopropyl ether (DIPE)	15	1.0	ug/L	12	121	70-130				
Ethyl tert-Butyl Ether (ETBE)	15	1.0	ug/L	12	123	70-130				
Methyl-t-butyl ether	16	1.0	ug/L	12	125	70-130				
tert-Amyl Methyl Ether (TAME)	16	1.0	ug/L	12	125	70-130				
tert-Butyl alcohol (TBA)	140	50	ug/L	120	115	60-140				

Surrogate: Toluene-d8      13      12      103      80-130

**Blank Spike Dup (A007267-BSD1) EPA 8260B - Quality Control**

1,2-Dibromoethane (EDB)	14	1.0	ug/L	12	115	70-130	0.6	30		
1,2-Dichloroethane	16	1.0	ug/L	12	130	70-130	2	30		
Di-isopropyl ether (DIPE)	15	1.0	ug/L	12	117	70-130	3	30		
Ethyl tert-Butyl Ether (ETBE)	15	1.0	ug/L	12	118	70-130	4	30		
Methyl-t-butyl ether	15	1.0	ug/L	12	123	70-130	2	30		
tert-Amyl Methyl Ether (TAME)	15	1.0	ug/L	12	122	70-130	3	30		
tert-Butyl alcohol (TBA)	160	50	ug/L	120	126	60-140	9	30		

Surrogate: Toluene-d8      13      12      104      80-130

Batch: A007269

Analyst: PYA

Prepared & Analyzed: 8/16/2010

**Blank (A007269-BLK1) 8015/8021 - Quality Control**

Benzene	ND	0.30	ug/L							
Ethylbenzene	ND	0.30	ug/L							
Toluene	ND	0.30	ug/L							
TPH as Gasoline	ND	50	ug/L							
Xylene (Total)	ND	0.30	ug/L							

Surrogate: Fluorobenzene      31      30      104      70-130

**Blank Spike (A007269-BS1) 8015/8021 - Quality Control**

Benzene	19	0.30	ug/L	20	93	70-130				
Ethylbenzene	18	0.30	ug/L	20	92	70-130				
Toluene	19	0.30	ug/L	20	94	70-130				
TPH as Gasoline	490	50	ug/L	500	98	70-130				
Xylene (Total)	56	0.30	ug/L	60	93	70-130				

Surrogate: Fluorobenzene      28      30      94      70-130

## Organics Quality Control Report

Analyte	Result	RL	Units	Spike Level	Source Result	%REC	Limits	RPD	RPD Limit	Qualifiers
---------	--------	----	-------	-------------	---------------	------	--------	-----	-----------	------------

Batch: A007269

Analyst: PYA

Prepared & Analyzed: 8/16/2010

**Blank Spike Dup (A007269-BSD1) 8015/8021 - Quality Control**

Benzene	20	0.30	ug/L	20		102	70-130	9	20	
Ethylbenzene	20	0.30	ug/L	20		101	70-130	10	20	
Toluene	21	0.30	ug/L	20		103	70-130	10	20	
Xylene (Total)	60	0.30	ug/L	60		101	70-130	8	20	
Surrogate: Fluorobenzene	30			30		102	70-130			

**Matrix Spike (A007269-MS1) 8015/8021 - Quality Control**

Source: A0H1054-01

Benzene	10	0.30	ug/L	10	ND	102	70-130			
Ethylbenzene	10	0.30	ug/L	10	ND	102	70-130			
Toluene	10	0.30	ug/L	10	ND	103	70-130			
Xylene (Total)	30	0.30	ug/L	30	ND	101	70-130			
Surrogate: Fluorobenzene	30			30		101	70-130			

Batch: A007279

Analyst: PYA

Prepared: 8/16/2010 Analyzed: 8/17/2010

**Blank (A007279-BLK1) 8015B - Quality Control**

TPH as Diesel	ND	100	ug/L							
Surrogate: Tetracosane	41			50		81.2	45-189			

**Blank Spike (A007279-BS1) 8015B - Quality Control**

TPH as Diesel	2500	100	ug/L	2500		100	70-130			
Surrogate: Tetracosane	69			50		138	45-189			

**Blank Spike Dup (A007279-BSD1) 8015B - Quality Control**

TPH as Diesel	2500	100	ug/L	2500		98.1	70-130	2.04	30	
Surrogate: Tetracosane	65			50		130	45-189			

**Matrix Spike (A007279-MS1) 8015B - Quality Control**

Source: A0H0796-01

TPH as Diesel	2400	100	ug/L	2500	77	91.2	70-130			
Surrogate: Tetracosane	62			50		125	45-189			

**Notes:**

- The Chain of Custody document and Sample Integrity Sheet are part of the analytical report.
- Any remaining sample(s) for testing will be disposed of one month from the final report date unless other arrangements are made in advance.
- Sample(s) received, prepared, and analyzed within the method specified criteria unless otherwise noted within this report.
- The results relate only to the samples analyzed in accordance with test(s) requested by the client on the Chain of Custody document. Any analytical quality control exceptions to method criteria that are to be considered when evaluating these results have been flagged and are defined in the data qualifiers section.
- All results are expressed on wet weight basis unless otherwise specified.
- All positive results for EPA Methods 504.1, 502.2, and 524.2 require the analysis of a Field Reagent Blank (FRB) to confirm that the results are not a contamination error from field sampling steps. If Field Reagent Blanks were not submitted with the samples, this method requirement has not been performed.
- Results contained in this analytical report must be reproduced in its entirety.
- Samples collected by BSK Analytical Laboratories were collected in accordance with the BSK Sampling and Collection Standard Operating Procedures.
- BSK Analytical Laboratories certifies that the test results contained in this report meet all requirements of the NELAC Standards for applicable certified drinking water chemistry analyses unless qualified or noted in the Case Narrative.
- Analytical data contained in this report may be used for regulatory purposes to meet the requirements of the Federal or State drinking water, wastewater, and hazardous waste programs.
- J-value is equivalent to DNQ (Detected, not quantified) which is a trace value. A trace value is an analyte detected between the MDL and the laboratory reporting limit. This result is of an unknown data quality and is only qualitative (estimated). Baseline noise, calibration curve extrapolation below the lowest calibrator, method blank detections, and integration artifacts can all produce apparent DNQ values, which contribute to the un-reliability of these values.
- (1) - Residual chlorine and pH analysis have a 15 minute holding time for both drinking and waste water samples as defined by the EPA and 40 CFR 136. Waste water and ground water (monitoring well) samples must be field filtered to meet the 15 minute holding time for dissolved metals. Samples submitted to the laboratory have been analyzed outside of this holding time requirement.
- \* - This is not a NELAP accredited analyte.
- Summations of analytes (i.e. Total Trihalomethanes) may appear to add individual amounts incorrectly, due to rounding of analyte values occurring before or after the total value is calculated, as well as rounding of the total value.
- (2) The digestion used to produce this result deviated from EPA 200.2 by excluding hydrochloric acid in order to produce acceptable recoveries for affected metals.

**Certifications:**

State of California - CDPH - ELAP	1180
State of California - CDPH - NELAP	04227CA
State of New Mexico - NMED-DWB	
State of Nevada - NDEP	CA000792009A

**Definitions and Flags for Data Qualifiers**

mg/L:	Milligrams/Liter (ppm)	M:	Method Detection Limit	MDA:	Min. Detected Activity
mg/Kg:	Milligrams/Kilogram (ppm)	RL:	Reporting Limit	MPN:	Most Probable Number
µg/L:	Micrograms/Liter (ppb)	:	DL x Dilution	CFU:	Colony Forming Unit
µg/Kg:	Micrograms/Kilogram (ppb)	ND:	None Detected at RL	Absent:	Less than 1 CFU/100mLs
%:	Percent Recovered (surrogates)	pCi/L:	Picocuries per Liter	Present:	1 or more CFU/100mLs

SC07 Sample received and analyzed without chemical preservation.

BS01 The associated blank spike recovery was above acceptance limits. Results were accepted based on duplicate spike.

A0H1054

**BSK Associates - Sacramento**

**BSKAs9293**

**08122010**

Erik Ringerburg  
No Project

Turnaround: Standard  
Duc Date: 08/26/2010

Sample ID	Sample Description	Date Sampled	Lab Notes
A0H1054-01	MW-6	08/04/2010	O.K. to run on Non-Preserved as per Jeff Y.
A0H1054-02	MW-101	08/04/2010	O.K. to run on Non-Preserved as per Jeff Y.
A0H1054-03	MW-5	08/04/2010	O.K. to run on Non-Preserved as per Jeff Y.
A0H1054-04	MW-7	08/04/2010	O.K. to run on Non-Preserved as per Jeff Y.



# BSK ANALYTICAL LABORATORIES

1414 Stanislaus, Fresno CA 93706  
 (559) 497-2888, (800) 877-8310, FAX (559) 485-6935

BSK Submission:   
 COC Number:   
 Global ID Number: T0600101370

A0H1054  
 BSKAs9293



Facility/Project Name: Unocal Castro Valley			Report Attention: Jeff Yeazell			Method Preserved					Anal							
Address			BSK Job No.: E0805401S			HCl	HNO3	H2SO4	NONE	OTHER (List)	BTEX/TPH-G (8020/8015M)	TPH-Diesel (8015M)	Fuel Oxygenates (8260B)	Lead Scavengers (8260B)				
City, State, Zip			Copy to:															
Phone			FAX															
Lab Use Only		Sampling Info		Sampled by: E. Basel														
S#	T	#C	Date	Time	Field Point Name													
1			8/4/10	9:10	NW-6						X	X	X	X				
2			8/4/10	10:32	NW-101						X	X	X	X				
3	✓		8/4/10	13:05	NW-5						X	X	X	X				
4	✓		8/4/10	13:36	NW-7						X	X	X	X				

QC Report Type: Level  2  3  4

Formal COC Required:

Electronic Data Format Required:

Email EDF To: jyeazell@bskinc.com

Low Level Fuel Oxygenates Detection Limits Req:

Signature	Print Name	Company	Date/Time
	Erin Basel	BSK/5	8/5/10/205
	Samantha Baric	BSK Lab	8/6/10/205

Sample Integrity

Pg. 1 of 2 WORK



Date Received 8/16/10

Section 1- Receiving Information

Sample Transport: ONTRAC UPS PMS Walk-In BSK-Courier GSO Fed Exp. Other: \_\_\_\_\_  
 Samples arrived at lab on same day sampled: Yes \_\_\_\_\_ No X (If Yes- Temperature is not needed)  
 Coolers/ice Chests Description/Temperature(s): (If more than 4 received, list information in comment section)  
 1) Ø 2) \_\_\_\_\_ 3) \_\_\_\_\_ 4) \_\_\_\_\_  
 Was Temperature In Range: Y N N/A Received On Ice: Wet Blue Received Ambient: Y N  
 Describe type of packing materials: Bubble Wrap Foam Packing Peanuts Paper Other: \_\_\_\_\_  
 Initial Receipt: BSK-Visalia BSK-Bakersfield BSK-SAC BSK-FDL BSK-FAL Ø  
 Were ice chest custody seals present? Y N Intact: Y N

Section 2- COC Info.

	Completed		Info From Container	Completed		Info From Container
	Yes	No		Yes	No	
Was COC Received	<u>---</u>					Analysis Requested
Date Sampled	<u>---</u>					Any hold times less than 72hr
Time Sampled	<u>---</u>					Client Name
Sample ID	<u>---</u>					Address
Special Storage/Handling Ins.		<u>-</u>				Telephone #

Section 3- Bottles / Analysis

	Yes	No	N/A	Comment
Did all bottles arrive unbroken and intact?	<u>---</u>			
Were bottle custody seals present?		<u>---</u>		
Were bottle custody seals intact?		<u>---</u>		
Did all bottle labels agree with COC?	<u>---</u>			
Were correct containers used for the tests requested?	<u>---</u>			
Were correct preservations used for the tests requested?	<u>---</u>			<u>*</u>
Was a sufficient amount of sample sent for tests indicated?	<u>---</u>			
Were bubbles present in VOA Vials? (Volatile Methods Only)		<u>---</u>		
Were Ascorbic Acid Bottles received with the VOAs?		<u>---</u>		

Section 4- Comments / Discrepancies

Sample(s) Split/Preserve: Yes Ø Container: \_\_\_\_\_ Preservation: \_\_\_\_\_ Dt/Time/Init \_\_\_\_\_

Container: \_\_\_\_\_ Preservation: \_\_\_\_\_ Dt/Time/Init \_\_\_\_\_

Was Client Service Rep. notified of discrepancies: Yes No N/A CSR: JLH Notified By: SF

Explanations / Comments

\* Receive unpreserve voa's for test requesting

Okay to run unpres as per Jeff Yearzoll

Report Comment Entered:

Labeled by: ML @ 17:41 Labels checked by: JLH @ 18:12

BSK Bottles  Yes  No



250ml (A) 500ml (B) 1Liter (C) Amber Glass (AG)

Container(s) Received	1-4				
Bacti Na <sub>2</sub> S <sub>2</sub> O <sub>3</sub>					
None (p) <small>White Cap</small>					
None (p) <small>Blue Cap</small> w/NH <sub>4</sub> + Buffer					
HNO <sub>3</sub> (p) <small>Red Cap</small>					
H <sub>2</sub> SO <sub>4</sub> (p) <small>Yellow Cap</small>					
NaOH (p) <small>Green Cap</small>					
Other:					
Dissolved Oxygen 300ml (g)					
Centrifuge Tube HNO <sub>3</sub>					
250ml (AG) None					
250ml (AG) H <sub>2</sub> SO <sub>4</sub> COD <small>Yellow Label</small>	1				
250ml (AG) Na <sub>2</sub> S <sub>2</sub> O <sub>3</sub> 515,547 <small>Blue Label</small>					
250ml (AG) Na <sub>2</sub> S <sub>2</sub> O <sub>3</sub> - MCAA 531.1 <small>Orange Label</small>					
250ml (AG) NH <sub>4</sub> Cl 552 <small>Purple Label</small>					
250ml (AG) EDA DBPs <small>Brown Label</small>					
250ml (AG) Other:					
500ml (AG) None					
500ml (AG) H <sub>2</sub> SO <sub>4</sub> TPH-Diesel <small>Yellow Label</small>					
1 Liter (AG) None					
1 Liter (AG) H <sub>2</sub> SO <sub>4</sub> O&G <small>Yellow Label</small>					
1 Liter (AG) Na <sub>2</sub> S <sub>2</sub> O <sub>3</sub> 548 / 525 / 521 <small>Blue Label</small>					
1 Liter (P) Na <sub>2</sub> S <sub>2</sub> O <sub>3</sub> + H <sub>2</sub> SO <sub>4</sub> 549					
1 Liter (AG) NaOH+ZnAc Sulfide					
1 Liter (AG) Ascorbic/EDTA/Pot Citrate 527 <small>Grey Label</small>					
1 Liter (AG) CuSO <sub>4</sub> /Trizma 529 <small>Turquoise Label</small>					
1 Liter (AG) Na <sub>2</sub> SO <sub>3</sub> / HCL 525 UCMR <small>Neon Green Label</small>					
1 Liter (AG) Ammonium Chloride 535 <small>Purple Label</small>					
40ml VOA Vial Clear - HCl					
40ml VOA Vial Amber - Na <sub>2</sub> S <sub>2</sub> O <sub>3</sub>					
40ml VOA Vial Clear - None	4				
40ml VOA Vial Clear - Na <sub>2</sub> S <sub>2</sub> O <sub>3</sub> 504, 505					
40ml VOA Vial Clear - H <sub>3</sub> PO <sub>4</sub>					
Other:					
Asbestos 1Liter Plastic/Foil					
Radon 200ml Clear (g)					
Low Level Hg/Metals Double Baggie					
Bioassay Jug					
250 Clear Glass Jar					
500 Clear Glass Jar					
1 Liter Clear Glass Jar					
Plastic Bag					
Soil Tube Brass / Steel / Plastic					
Tedlar Bags					

S

8/12/10  
S