



Nahas Company, LLC
Real Estate Services

130 Ryan Industrial Ct., Ste. 200
P. O. Box 3059
San Ramon, CA 94583
925-855-1978
Fax. 925-855-1414

RECEIVED

2:51 pm, Jun 01, 2009

**Alameda County
Environmental Health**

May 26, 2009

Alameda County Environmental Health
Attn: Barbara Jakub, P.G.
1131 Harbor Bay Parkway, Suite 250
Alameda, CA 94502-6577

**Subject: Status Report
First Quarter 2009
Former Unocal Service Station
20405 Redwood Road
Castro Valley, California**

Dear Ms. Jakub:

Enclosed please find a copy of the subject Status Report dated May 21, 2009, prepared by BSK Associates.

I declare, under penalty of perjury, that the information and/or recommendations contained in the attached document or report is true and correct to the best of my knowledge.

Sincerely,

Randal Nahas



**STATUS REPORT
FIRST QUARTER 2009**

**FORMER UNOCAL SERVICE STATION
20405 REDWOOD ROAD
CASTRO VALLEY, CALIFORNIA**

BSK PROJECT E0805401S

PREPARED FOR:

**MR. RANDY NAHAS
P.O. BOX 3049
SAN RAMON, CA 94583**

MAY 21, 2009

Engineers, Geologists, Inspectors and Scientists

**STATUS REPORT
FIRST QUARTER 2009
FORMER UNOCAL SERVICE STATION
20405 REDWOOD ROAD
CASTRO VALLEY, CALIFORNIA**

Prepared for:

Mr. Randall Nahas
P.O. Box 3059
San Ramon, CA 94583

BSK Project: E0805401S

May 21, 2009



Jeffrey G. Yeazell
Project Manager

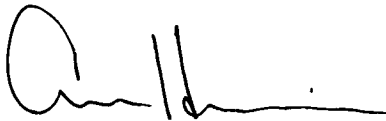

Amer A. Hussain, PE
Senior Engineer



BSK Associates
3140 Gold Camp Drive, Suite 160
Rancho Cordova, CA 95670
(916) 853-9293
(916) 853-9297 FAX
www.bskinc.com

TABLE OF CONTENTS

1.0	INTRODUCTION	1
2.0	PROJECT SITE DESCRIPTION AND HISTORY	1
3.0	PURPOSE AND SCOPE.....	4
4.0	GROUNDWATER FLOW DIRECTION	4
5.0	GROUNDWATER SAMPLING AND ANALYTICAL RESULTS	5
6.0	LIMITATIONS.....	5
7.0	REFERENCES	5

TABLES

Table 1: Soil Sample Analytical Results

Table 2: Soil Sample Analytical Results – Volatile and Semi-Volatile Organic Compounds

Table 3: Groundwater Monitoring Analytical Results – Petroleum Hydrocarbon Constituents

Table 4: Groundwater Monitoring Analytical Results – Volatile Organic Compounds

Table 5: Summary of Groundwater Elevation Data

Table 6: Summary of Groundwater Flow Direction and Gradient Data

FIGURES

Figure 1: Site Vicinity Map

Figure 2: Site Plan

Figure 3: Extent of Excavations and Excavation Soil Sample Locations

Figure 4: Generalized Groundwater Elevation Map - February 2009

Figure 5: MW-2 Time Series Plots

Figure 6: MW-3 Time Series Plots

Figure 7: MW-6 Time Series Plots

Figure 8: MW-7 Time Series Plots

Figure 9: MW-101 Time Series Plots

APPENDICES

Appendix A: Water Sample Logs

Appendix B: Laboratory Data Reports and Chain of Custody Documentation

**STATUS REPORT
FIRST QUARTER 2009
FORMER UNOCAL SERVICE STATION
20405 REDWOOD ROAD
CASTRO VALLEY, CALIFORNIA**

1.0 INTRODUCTION

At the request of Mr. Randall Nahas, BSK Associates performed groundwater monitoring and prepared this report summarizing data collected from the semi-annual monitoring of six groundwater monitoring wells located at the Former Unocal Service Station, 20405 Redwood Road, Castro Valley, California (the site). The site vicinity is shown on Figure 1.

2.0 PROJECT SITE DESCRIPTION AND HISTORY

December 1989, Soil Investigation and Monitoring Well Installation: In December 1989, three groundwater monitoring wells (MW-2, MW-3 and MW-4) were installed at the locations shown on Figure 2. Soil samples were collected from soil borings MW-1 and MW-1A; however, they were not converted to monitoring wells (BSK, 1995). Summaries of soil sample analytical results are presented in Table 1 (petroleum hydrocarbons) and Table 2 (volatile and semi-volatile organic compounds). Monitoring well groundwater sample analytical results are summarized in Table 3.

March 1991, Soil Investigation: Thirteen soil borings (SB-1 through SB-13) were advanced at the locations shown on Figure 2 to depths ranging between approximately 10 and 20 feet bgs (BSK, 1996). Soil sample analytical results are summarized in Table 1.

March through April 1992, Soil Borings and Monitoring Well Installation: Soil borings MW-5, MW-6, MW-7, SB-14, and SB-15 were drilled at the locations shown on Figure 2. A summary of soil sample analytical results is presented in Table 1. Borings MW-5, MW-6, and MW-7 were completed as groundwater monitoring wells.

October 1992, Chromatograph Evaluation: BSK identified a non-standard peak in the chromatograph from a groundwater sample from well MW-7. The peak was not typical of petroleum hydrocarbons.

November 1992, Groundwater Sampling: Groundwater samples from monitoring well MW-7 were analyzed for volatile halocarbons by EPA Method 601. Analytical results are summarized in Table 3. Tetrachloroethylene (PCE) and trichloroethylene (TCE) were detected in groundwater samples from well MW-7 at concentrations of 14,000 µg/L and 660 µg/L, respectively. BSK Associates attributed the previous concentrations of TPHg to the presence of PCE and concluded gasoline contamination may not occur in a significant quantity in monitoring well MW-7 and attributed the contamination to another source. BSK Associates recommended ceasing any further investigation of the gasoline plume south of well MW-7 (BSK, 1992b).

November 1993, Soil Borings: Soil borings SP-1 and SP-2 were advanced at the locations shown on Figure 2. Soil and groundwater samples were collected from each boring. Summaries of soil sample analytical results are presented in Table 1 (petroleum hydrocarbons) and Table 2 (volatile and semi-volatile organic compounds). Monitoring well groundwater sample analytical results are summarized in Table 3 (Philip Environmental, 1996).

December 1995, Feasibility Study: Excavation and on-site treatment of excavated soil was selected as the remedial alternative for soil impacts. As a part of the feasibility study, an aquifer pump test was conducted. Groundwater extraction well MW-101 was installed at the location shown on Figure 2. Pump-and-treat was determined to be a feasible remedial alternative for groundwater impacts at the site. (BSK, 1995).

June 1996, Revised Corrective Action Plan: Philip Environmental prepared a Revised Corrective Action Plan. The plan stated that the site operator and property owner planned to cease operation of the site as a service station, which would require closure of the underground storage tanks. Philip Environmental recommended removal of the USTs, soil excavation and limited groundwater extraction (Philip Environmental, 1996).

As part of the Revised Corrective Action Plan, Tier I and Tier II Risk Assessments were conducted. Results of the Tier I Risk Assessment show benzene levels in soil at the site exceeded the risk based screening levels for volatilization from soil to outdoor air, vapor intrusion from soil to on-site buildings, soil ingestion, and leachate from soil to water exposure pathways. Toluene levels in soil at the site exceeded the risk based screening levels for the vapor intrusion from soil to on-site buildings exposure pathway. Results of the Tier II Risk Assessment indicated that concentrations of phase separated hydrocarbons and benzene in soil and groundwater exceed Tier II site specific screening levels in the area adjacent to the USTs and the southern property boundary (Philip Environmental, 1996).

Summer 1997, Service Station Building Demolition: The service station building was demolished and fuel dispensers removed (Life Springs Environmental Inc., 1999).

November 1998, UST Removal: The concrete slabs and foundation of the building, fueling area, and pump islands, were broken up and hauled to a recycling facility. The three USTs and associated piping were removed and transported to Ecology Control Industries (ECI) in Richmond, California. Two hydraulic hoists and clarifier sump were also removed. No holes were observed in the gasoline USTs, but small holes were observed in the waste oil UST. The excavated soil (approximately 175 cubic yards) was stockpiled. Figure 3 shows the approximate extent of the excavation.

Soil samples were collected after excavation. Sample locations are shown on Figure 3. Tables 1 and 2 provide summaries of soil sample analytical results. The release of petroleum hydrocarbons at the site appears to have primarily impacted the backfill material surrounding the two 10,000 gallon gasoline USTs (Life Springs Environmental Inc., 1999).

The UST pit was backfilled with aggregate base to within 5 feet of ground surface. Winter weather conditions led Life Springs Environmental Inc. to place impacted soil back in the excavations of the waste oil UST and clarifier sump (Life Springs Environmental Inc., 1999).

April 1999, Stockpiled Soil Remediation: Beginning in April 1999, impacted soil from the main UST excavation was laid out in shallow beds and aerated by periodic tilling.

May 1999, Soil Re-Excavation and Sampling: The waste oil UST and clarifier sump areas were re-excavated, with the second excavation extending slightly deeper than the first. Excavated soil from the waste oil UST and clarifier sump pits was disposed of at Vasco Road Sanitary Landfill in Livermore, California (Life Springs Environmental Inc., 2000). Soil samples were collected from native soil in both pits and analyzed for TPHd and total oil and grease. A section of the pipe trench area was excavated to a depth of 3 feet bgs. Excavated soil from the trench was laid out in shallow beds for aeration. A soil sample was collected from the trench re-excavation (sample name: GASLINE). The sample was analyzed for TPHg/BTEX and MTBE. Table 1 provides a summary of soil sample analytical results. Figure 3 shows the approximate extent of re-excavation and sample locations.

August 1999, Waste Oil and Clarifier Sump Pit Sampling and Soil Stockpiling: The aerated soil from previous excavations was stockpiled. Soil samples were collected from the bottom of the waste oil and clarifier sump pits at depths of 10 and 7 feet bgs respectively (Life Springs Environmental Inc., 1999). Table 1 provides a summary of soil sample analytical results, Figure 3 shows the approximate sample locations.

September 1999, Waste Oil Pit Sampling: A soil sample was collected from within the waste oil pit at a depth of 11.5 bgs and analyzed for chlorinated hydrocarbons and TPHd. Table 1 provides a summary of soil sample analytical results, Figure 3 shows the approximate sample location.

October 1999, Clarifier Sump Pit Sampling: A soil sample was collected within the clarifier sump pit at a depth of 9.5 feet bgs. Table 1 provides a summary of soil sample analytical results, Figure 3 shows the approximate sample location.

November 1999, Permission to Re-Use Stockpiled Soil: Permission was granted by Alameda County Environmental Health Services for the re-use of the stockpiled soil that had been remediated by aeration (Life Springs Environmental Inc., 2000).

December 1999, Waste Oil and Clarifier Sump Pit Deepening and Sampling: The waste oil pit was deepened to 10 feet bgs and the clarifier sump pit was deepened to 14 feet bgs. Soil removed from the over-excavation was also transported to the Vasco Road Sanitary Landfill in Livermore, California. Approximately 36.1 tons of soil were removed from both the waste oil pit and the clarifier sump pit during both re-excavation and over-excavation events. Soil samples were collected from the native soil in the bottom of each pit. The two excavations along with the final five feet of the main excavation were filled in with the remediated soil from the main excavation. Table 1 provides a summary of soil sample analytical results. Figure 3 shows the approximate extent of the over-excavation and sample locations.

Monitoring well MW-4 was abandoned by pressure grouting and drilling out. The vault boxes for monitoring wells MW-2 and MW-101 were replaced (Life Springs Environmental Inc., 2000).

Groundwater Monitoring Program: From August 1990 through 1999, groundwater monitoring activities were performed on a quarterly basis. Groundwater monitoring was performed semi-annually starting in 1999 through September 2003. Groundwater monitoring was not conducted from the third quarter of 2003 through the third quarter of 2008. Groundwater monitoring analytical data are summarized in Table 3 (petroleum hydrocarbon constituents) and Table 4 (volatile organic hydrocarbons). Groundwater elevation data is summarized in Table 5.

3.0 PURPOSE AND SCOPE

The purpose of quarterly monitoring is to collect data on groundwater quality, groundwater depths, and direction of flow beneath the subject property with the intention of evaluating residual hydrocarbon contamination in groundwater beneath the site. BSK performed the following tasks:

- Measured depth to groundwater in four of the six monitoring wells on February 5, 2009. At the time of sampling, monitoring wells MW-2 and MW-3 were inaccessible because they were covered by a layer of mulch. BSK later located the two wells using a magnetic locator device on February 11, 2009. Both wells were then sampled that day.
- Purged and sampled the six groundwater monitoring wells;
- Analyzed groundwater samples from each accessible monitoring well, for:
 - Total petroleum hydrocarbons as diesel (TPHd)
 - Total petroleum hydrocarbons as gasoline (TPHg)
 - Benzene, toluene, ethylbenzene, and xylenes (BTEX)
 - Fuel Oxygenates
 - Lead Scavengers
- Prepared this quarterly monitoring report summarizing the condition of the wells, depth to groundwater, groundwater flow direction, and laboratory analytical results.

4.0 GROUNDWATER FLOW DIRECTION

Groundwater depths were measured in the four accessible monitoring wells prior to purging and sampling on February 5, 2009 and February 11, 2009. Depths were measured relative to the north side of the top of each well casing. Sample logs from February 11, 2009 were inadvertently misplaced by the sample technician and the information on them is no longer available.

Based on our measurements, groundwater generally flowed approximately south-southeast, with a general hydraulic gradient of 0.01 feet/foot. Figure 4 presents a groundwater elevation contour map for the recent monitoring event, and includes a rose diagram depicting the groundwater flow direction. Table 5 summarizes groundwater elevations recorded during the investigation. Table 6 summarizes associated groundwater gradient and flow direction data.

5.0 GROUNDWATER SAMPLING AND ANALYTICAL RESULTS

Groundwater sampling was conducted on February 6 and 11, 2009. Each well was purged of a minimum of three casing volumes using an electric submersible pump. Water temperature, pH, and conductivity were measured after removal of each approximate casing volume. The purged water was discharged to the on-site ponds. Water sample logs are included in Appendix A.

After purging, water samples were collected from each well using a clean disposable bailer. The samples were labeled with the sample identification, date and time collected, and project identification. Samples were preserved in a chilled cooler and transported with completed chain-of-custody forms to BSK's state-certified analytical laboratory. The samples were analyzed for TPHd and TPHg by EPA Method 8015B, BTEX by EPA Method 8021B, and fuel oxygenates and lead scavengers by EPA Method 8260B. Equipment used during purging and sampling activities was cleaned with non-phosphate detergent wash and rinsed prior to use at each well location. The purged groundwater was stored in appropriately-labeled 55-gallon drums at the site.

Tables 3 and 4 summarize past quarterly monitoring analytical results. Figures 5 through 9 present time series plots for monitoring wells MW-2, MW-3, MW-6, MW-7, and MW-101 respectively. Appendix B contains laboratory data reports and chain-of-custody documentation for the samples collected this quarter.

6.0 LIMITATIONS

This report has been prepared for the exclusive use of Mr. Randall Nahas. Unauthorized use of or reliance on the information contained in this report by others, unless given the express written consent by BSK Associates, is prohibited.

The conclusions presented in this report are professional opinions based on the indicated data described in this report. This report has been prepared in accordance with generally accepted methodologies and standards of professional practice. No other warranties, either expressed or implied, are made as to the findings or conclusions included in the report. Conclusions and recommendations are intended only for the purpose, site location and project indicated.

Opinions presented in this report apply to site conditions existing at the time of our study and those reasonably foreseeable. They cannot necessarily apply to site changes of which this office is not aware and has not evaluated. Changes in the conditions of the subject property may occur with time, because of natural processes or the works of man, on the subject site or on adjacent properties.

7.0 REFERENCES

BSK 1992a, *Off Site Soil and Groundwater Contamination Characterization and Seventh Quarterly Groundwater Monitoring Report*, Unocal Service Station 20405 and 20629 Redwood Road, Castro Valley, California, May 29, 1992.

- BSK 1992b, *Letter Report, Well MW-7 Special Sampling, Unocal Service Station/Safeway Parking Lot, 20405 and 20629 Redwood Road, Castro Valley, California, December 23, 1992.*
- BSK 1995, *Feasibility Study, Soil and Groundwater Remediation, Tien's Unocal Station, 20405 Redwood Road, Castro Valley, California, December 11, 1995.*
- BSK, 1996, *Semi-Annual Groundwater Monitoring Report, Unocal 76 Service Station, 20405 and 20629 Redwood Road, Castro Valley, California, BSK Associates, May 14, 1996.*
- Philip Environmental 1996, *Revised Corrective Action Plan, R.T. Nahas Property/Tien Unocal 76 Service Station, 20405 Redwood Road, Castro Valley, California, June 14, 1996.*
- Life Springs Environmental, Inc. 1999, *Technical Report, Tank Closure, Underground Fuel Tank Site, R.T. Nahas Company Property, Formerly Frank Tien Unocal 76 Service Station, 20405 Redwood Road, Castro Valley, California, 94546, February 18, 1999.*
- Life Springs Environmental, Inc. 1999, *Soil Remediation Status Report, R.T. Nahas Property, Castro Valley, August 17, 1999.*
- Life Springs Environmental, Inc. 1999, *Soil Remediation Status Report #2, R.T. Nahas Property, Castro Valley, October 26, 1999.*
- Life Springs Environmental, Inc. 2000, *Technical Report, Soil Remediation Closure Report, Underground Fuel Tank Site, R.T. Nahas Company Property, Formerly Frank Tien Unocal 76 Service Station, 20405 Redwood Road, Castro Valley, California, 94546, April 13, 2000.*
- Graymer, R.W., 2000, *Geologic map and map database of the Oakland metropolitan area, Alameda, Contra Costa, and San Francisco Counties, California: U.S. Geological Survey, Miscellaneous Field Studies Map MF-2342, scale 1:50000.*
- BSK, 2003, *Report, Eighth Semi-Annual Groundwater Monitoring (Third Quarter 2003), Former Unocal 76 Service Station, 20405 and 20629 Redwood Road, Castro Valley, California, BSK Associates, May 14, 1996.*

Table 1
Soil Sample Analytical Results
Former Unocal Service Station
20405 Redwood Road
Castro Valley, California

Location	Depth (feet bgs)	TPHg (mg/kg)	TPHd (mg/kg)	Benzene (mg/kg)	Toluene (mg/kg)	Ethylbenzene (mg/kg)	Xylenes (mg/kg)	Oil and Grease (mg/kg)	Total Lead (mg/kg)	MTBE (mg/kg)
December 1989, Soil Investigation and Monitoring Well Installation										
MW-1	5	<10	-	<0.02	<0.02	<0.02	<0.02	-	-	-
	10	89	-	1.8	7.8	3.8	20	-	-	-
	15	<10	-	0.09	<0.02	<0.02	<0.02	-	-	-
	19	<10	-	<0.02	<0.02	<0.02	<0.02	-	-	-
MW-1A	5	<10	<10	<0.02	<0.02	<0.02	<0.02	-	<2.0	-
	10	110	50 ^b	2.2	11	5.4	25	-	<2.0	-
	13	11	<10	0.64	0.71	0.64	3.5	-	<2.0	-
	16.5	<10	<10	<0.02	<0.02	<0.02	<0.02	-	<2.0	-
MW-2	5	<10	-	<0.02	<0.02	<0.02	<0.02	-	-	-
	10	<10	-	0.05	<0.02	<0.02	0.03	-	-	-
	15	<10	-	<0.02	<0.02	<0.02	<0.02	-	-	-
	20	<10	-	<0.02	<0.02	<0.02	<0.02	-	-	-
MW-3	5	<10	-	<0.02	<0.02	<0.02	<0.02	-	-	-
	10	<10	-	<0.02	<0.02	<0.02	<0.02	-	-	-
	15	92	-	ND	ND	0.97	4.0	-	-	-
	19	<10	-	<0.02	<0.02	<0.02	<0.02	-	-	-
MW-4 ^a	5	-	<10	<0.02	<0.02	<0.02	<0.02	<100	-	-
	8.5	-	<10	<0.02	<0.02	<0.02	<0.02	<100	-	-
	13	-	<10	<0.02	<0.02	<0.02	<0.02	<100	-	-
March 1991, Soil Investigation										
SB-1	14.5	<10	-	0.05	0.03	<0.02	0.06	-	-	-
SB-2	10.5	440	-	4.5	18	11	55	-	<2.0	-
	13	810	340 ^b	5.3	4.2	13	76	-	-	-
SB-3	13.5	15	<10	0.09	0.18	0.19	1.1	-	<2.0	-
	17	<10	-	<0.02	<0.02	<0.02	<0.02	-	-	-
SB-4	14	<10	<10	<0.02	<0.02	<0.02	0.1	-	-	-
SB-5	14.5	<10	-	<0.02	<0.02	<0.02	<0.02	-	-	-
SB-6	15	310	-	0.8	15	6.2	36	-	-	-
SB-8	20.5	<10	-	<0.02	<0.02	<0.02	<0.02	-	-	-
SB-10	16	<10	-	<0.02	<0.02	<0.02	<0.02	-	-	-
SB-11	10.5	31	-	0.09	0.03	0.49	1.8	-	-	-
SB-12	15.5	<10	-	<0.02	<0.02	<0.02	<0.02	-	-	-
SB-13	10.5	1100	-	5.5	67	27	140	-	-	-
	14	530	-	7.8	48	14	73	-	-	-
March through April 1992, Soil Borings and Monitoring Well Installation										
SB-14	21	<1	<1	<0.005	<0.005	<0.005	<0.005	-	-	-
SB-15	20.5	<1	3	<0.005	0.007	<0.005	<0.008	-	-	-
	21	<1	<1	<0.005	<0.005	<0.005	<0.005	-	-	-
MW-5	21	<1	<1	<0.005	<0.005	<0.005	<0.005	-	-	-
MW-6	16	<1	<1	<0.005	<0.005	<0.005	<0.005	-	-	-
MW-7	15.5	<1	<1	<0.005	<0.005	<0.005	<0.005	-	-	-
November 1993, Soil Borings										
SP-2	14	9	-	0.14	0.52	0.19	1.0	-	-	-
SP-1	16	-	-	0.18	<0.005	0.075	0.055	-	-	-
December 1995, Monitoring Well Installation										
MW-101	10	120	-	<0.005	0.95	2.1	11	-	-	-
	15	63	-	ND	1.5	0.87	9.8	-	-	-

Table 1
Soil Sample Analytical Results
Former Unocal Service Station
20405 Redwood Road
Castro Valley, California

Location	Depth (feet bgs)	TPHg (mg/kg)	TPHd (mg/kg)	Benzene (mg/kg)	Toluene (mg/kg)	Ethylbenzene (mg/kg)	Xylenes (mg/kg)	Oil and Grease (mg/kg)	Total Lead (mg/kg)	MTBE (mg/kg)
November 1998, UST Removal										
WO	8	<1.0	270	<0.005	0.0061	0.027	0.079	2300	9.0	<0.005
PIT NE COR	12	47	-	<0.62	<0.62	0.74	3.4	-	-	<0.62
PIT NE BOT	13	14	-	<0.62	<0.62	<0.62	<0.62	-	-	<0.62
PIT SE	12	31	-	<0.62	1.8	<0.62	3.0	-	-	<0.62
PIT SE	unk	100	-	<2.5	<2.5	2.6	14	-	-	<2.5
PIT SW	11.5	22	-	<0.62	<0.62	<0.62	3.0	-	-	<0.62
PIT NW	12	2.6	-	0.088	0.0054	0.11	0.52	-	-	0.014
WL NW	2	<1.0	-	<0.005	<0.005	<0.005	<0.005	-	-	0.018
WL J	2	<1.0	-	<0.005	<0.005	<0.005	<0.005	-	-	<0.005
WIS S	2	410	-	3.6	11	12	72	-	-	0.80
WIS N	2	<1.0	-	<0.005	<0.005	<0.005	<0.005	-	-	<0.005
EJ	2	<1.0	-	<0.005	<0.005	<0.005	<0.005	-	-	<0.005
EIS S	2	<1.0	-	<0.005	<0.005	<0.005	<0.005	-	-	<0.005
EIS N	2	<1.0	-	<0.005	<0.005	<0.005	<0.005	-	-	<0.005
CJ	2	<1.0	-	<0.005	<0.005	<0.005	<0.005	-	-	<0.005
WEST HOIST ³	8.5	-	1000 ^{*1}	-	-	-	-	-	-	-
EAST HOIST ³	8.5	-	<1.0 ^{**}	-	-	-	-	-	-	-
SUMP	4.5	<1.0	120 ¹	<0.005	<0.005	<0.005	<0.005	96	7.9	<0.005
May 1999, Soil Re-excavation and Sampling										
GASLINE	3	<1.0	-	<0.005	<0.005	<0.005	<0.005	-	-	-
SUMP	4	-	2700 ¹ /4800 ^c	-	-	-	-	-	-	-
WO	9	-	38 ¹	-	-	-	-	140	-	-
August 1999, Waste Oil and Clarifier Sump Pit Sampling										
SUMP	7	-	84	-	-	-	-	88	-	-
WO	10	-	560	-	-	-	-	1400	-	-
September 1999, Waste Oil Pit Sampling										
WO	11.5	<1.0	1.2 ¹	<0.005	<0.005	<0.005	<0.005	<50	-	-
October 1999, Clarifier Sump Pit Sampling										
SUMP ³	9.5	71 ¹	270 ²	<0.62	<0.62	<0.62	<0.62	220	-	<0.62
December 1999, Waste Oil and Clarifier Sump Pit Deepening and Sampling										
WO ³	11	<1.0	<1.0	<0.005	<0.005	<0.005	<0.005	<50	-	<0.005
SUMP ³	15	6.3 ¹	690 ¹	<0.005	<0.005	0.14	0.25	1200	-	<0.005
Notes:										
-: Not analyzed.										
unk: Unknown.										
¹ : Hydrocarbon reported does not match the pattern of Chromalab, Inc. standard.										
² : Estimated concentration reported due to overlapping fuel patterns.										
³ : Exact location not mapped.										
* West Hoist also had 2000 mg/kg hydraulic oil.										
^{**} East Hoist <50 mg/kg hydraulic oil.										
^a . Soil samples at were also analyzed for VOCs by EPA method 8010. None were detected.										
^b . Sample contains lower molecular weight hydrocarbons.										
^c . Reported as motor oil										

Table 2
Soil Sample Analytical Results
Volatile and Semi-Volatile Organic Compounds
Former Unocal Service Station
20405 Redwood Road
Castro Valley, California

Well	Depth	Phenanthrene (mg/kg)	Fluoranthene (mg/kg)	Pyrene (mg/kg)	bis(2-Ethylhexyl) phthalate (mg/kg)
December 1989, Soil Investigation and Monitoring Well Installation					
MW-4*	5	-	-	-	-
	8.5	-	-	-	-
	13	-	-	-	-
November 1993, Soil Borings					
SP-2*	1	-	-	-	-
SP-1*	16	-	-	-	-
November 1998, UST Removal					
WO	8	0.10	0.17	0.22	0.6
SUMP	4.5	<0.10	<0.10	<0.10	<0.50
August 1999, Waste Oil and Clarifier Sump Pit Sampling					
SUMP	7	<0.10	<0.10	<0.10	<0.50
WO	10	<0.10	0.13	0.20	0.82
September 1999, Waste Oil Pit Sampling					
WO	11.5	<0.10	<0.10	<0.10	<0.50
Notes:					
-: Not analyzed					
*: Samples were analyzed for VOCs by EPA Method 8260 only; none were detected above reportable detection limits					

Table 3
Groundwater Monitoring Analytical Results - Petroleum Hydrocarbon Constituents
Former Unocal Service Station
20405 Redwood Road
Castro Valley, California

Well	Date	TPHg (µg/L)	TPHd (µg/L)	Total Oil and Grease (µg/L)	Benzene (µg/L)	Toluene (µg/L)	Ethylbenzene (µg/L)	Xylenes (µg/L)	MTBE (µg/L)
MW-2	12/89	72	.	.	<0.5	<0.5	<0.5	<0.5	.
	08/90	180	.	.	21	3.9	7.2	28	.
	01/91	430	.	.	50	33	22	110	.
	04/91	4,800	.	.	640	520	140	790	.
	07/91	220	.	.	14	1	17	8	.
	10/91	170	.	.	2.9	ND	2.5	6	.
	01/92	5,200	.	.	480	870	160	860	.
	4/20/92	300	.	.	70	0.3	15	7	.
	7/9/92	84	.	.	10	ND	0.6	2.3	.
	10/8/92	ND	.	.	2.3	ND	2.3	3	.
	1/12/93	170	.	.	11	5.1	1.4	6.3	.
	3/4/93	720	.	.	110	32	67	28	.
	7/1/93	220	.	.	17	1.1	6	12	.
	10/19/93	98	.	.	4.0	ND	2.3	3.1	.
	1/12/94	130	.	.	13	3.4	4.9	9.2	.
	4/25/94	270	.	.	23	1.1	8.2	17	.
	7/28/94	180	.	.	14	0.7	5.8	12	.
	10/13/94	97	.	.	2.8	ND	2.9	1.8	.
	1/10/95	440	.	.	48	2.8	15	27	.
	4/19/95	480	.	.	72	2.8	47	22	.
	10/12/95	450	.	.	7.4	ND	5.1	5.5	.
	4/12/96	690	.	.	41	2.8	27	50	.
	10/8/96	180	.	.	9.4	0.5	7.2	9.4	1,400
	4/9/97	470	.	.	23	1.6	21	31.4	1,800
	11/5/97	360	.	.	6.8	0.64	4.7	8.2	1,200
	3/1/00	560	.	.	14	0.92	16	24	1,400
	09/00	180	.	.	0.89	ND	1	0.65	620
	3/22/01	1,000	.	.	ND	ND	ND	ND	1,300 ¹ /1,200
	8/23/01	160	.	.	22	1.5	17	27	690 ¹ /820
	03/02	140	.	.	2.6	0.31	2	1.7	420
10/02	92	.	.	ND	ND	ND	ND	280	
03/03	IA	IA	IA	IA	IA	IA	IA	IA	
9/17/03	IA	IA	IA	IA	IA	IA	IA	IA	
11/20/08	IA	IA	IA	IA	IA	IA	IA	IA	
2/11/09*	<50	<50	.	.	<0.3	<0.3	<0.3	<0.3	62

Table 3
Groundwater Monitoring Analytical Results - Petroleum Hydrocarbon Constituents
Former Unocal Service Station
20405 Redwood Road
Castro Valley, California

Well	Date	TPHg (µg/L)	TPHd (µg/L)	Total Oil and Grease (µg/L)	Benzene (µg/L)	Toluene (µg/L)	Ethylbenzene (µg/L)	Xylenes (µg/L)	MTBE (µg/L)
MW-3	12/89	<50	-	-	<0.5	<0.5	<0.5	<0.5	-
	08/90	290	-	-	55	3.8	20	59	-
	01/91	110	-	-	29	3.3	9.7	34	-
	04/91	3,600	-	-	450	270	150	760	-
	07/91	220	-	-	14	14	33	8.0	-
	10/91	ND	ND	ND	ND	ND	ND	ND	-
	01/92	60	-	-	4.0	10	2.0	8.0	-
	4/20/92	ND	-	-	1.0	0.4	ND	0.9	-
	7/9/92	ND	-	-	1.3	0.40	ND	1.3	-
	10/8/92	ND	-	-	2.1	ND	ND	0.30	-
	1/12/93	ND	-	-	1.2	1.0	0.60	4.1	-
	3/4/93	330	-	-	32	0.90	64	13	-
	7/1/93	330	-	-	24	11	14	82	-
	10/19/93	ND	-	-	5.0	ND	0.60	1.2	-
	1/12/94	69	-	-	13	3.4	4.9	9.2	-
	4/25/94	62	-	-	17	1.0	4.9	24	-
	7/28/94	52	-	-	7.2	0.4	1.6	4.6	-
	10/13/94	ND	-	-	0.9	ND	ND	ND	-
	1/10/95	250	-	-	26	0.60	14	45	-
	4/19/95	450	-	-	26	0.60	40	19	-
	10/12/95	340	-	-	9.0	3.9	8.5	34	-
	4/12/96	170	-	-	41	2.8	27	50	-
	10/8/96	79	-	-	3.8	1.5	2.1	6.8	55
	4/9/97	120	-	-	7.3	ND	3.3	5.4	230
	11/5/97	62	-	-	1.7	1.4	2.3	8.3	65
	3/1/00	96	-	-	0.61	ND	ND	ND	240
	09/00	ND	-	-	ND	ND	ND	ND	98
	3/22/01	ND	-	-	ND	ND	ND	ND	190
	8/23/01	ND	-	-	ND	ND	ND	ND	26
	03/02	ND	-	-	ND	ND	ND	ND	26
	10/02	ND	-	-	ND	ND	ND	ND	15
	03/03	IA	IA	IA	IA	IA	IA	IA	IA
	9/17/03	ND	-	-	ND	ND	ND	ND	13
	11/20/08	IA	IA	IA	IA	IA	IA	IA	IA
	2/11/09*	<50	<50	-	<0.3	<0.3	<0.3	<0.3	12

Table 3
Groundwater Monitoring Analytical Results - Petroleum Hydrocarbon Constituents
Former Unocal Service Station
20405 Redwood Road
Castro Valley, California

Well	Date	TPHg (µg/L)	TPHd (µg/L)	Total Oil and Grease (µg/L)	Benzene (µg/L)	Toluene (µg/L)	Ethylbenzene (µg/L)	Xylenes (µg/L)	MTBE (µg/L)
MW-4	12/89	<50	<100	<5,000	<0.5	<0.5	<0.5	<0.5	
	08/90	ND	ND	ND	ND	ND	ND	ND	
	01/91	-	-	-	-	-	-	-	
	04/91	ND	ND	ND	ND	ND	ND	ND	
	07/91	-	-	-	-	-	-	-	
	10/91	ND	ND	ND	ND	ND	ND	ND	
	01/92	-	-	-	-	-	-	-	
	4/20/92	ND	ND	ND	ND	ND	ND	ND	
	7/9/92	-	-	-	-	-	-	-	
	10/8/92	ND	120	ND	ND	ND	ND	ND	
	1/12/93	ND	ND	ND	ND	ND	ND	ND	
	3/4/93	ND	ND	ND	ND	ND	ND	ND	
	7/1/93	ND	ND	1,000	ND	ND	ND	ND	
	10/19/93	ND	ND	ND	0.40	ND	ND	0.40	
	4/25/94	ND	ND	ND	ND	ND	ND	0.40	
	7/28/94	ND	86	ND	ND	0.60	ND	ND	
	10/13/94	70	ND	ND	ND	36	ND	1.3	
	1/10/95	ND	ND	2,000	ND	ND	ND	ND	
4/19/95	ND	ND	ND	ND	ND	ND	ND		
10/12/95	ND	ND	-	ND	ND	ND	ND		
4/12/96	ND	ND	-	ND	ND	ND	ND		
10/8/96	ND	ND	-	ND	ND	ND	ND	ND	
4/9/97	ND	ND	-	ND	ND	ND	ND	ND	
11/5/97	ND	ND	-	ND	ND	ND	ND	ND	
Abandoned December 1999.									

Table 3
Groundwater Monitoring Analytical Results - Petroleum Hydrocarbon Constituents
Former Unocal Service Station
20405 Redwood Road
Castro Valley, California

Well	Date	TPHg (µg/L)	TPHd (µg/L)	Total Oil and Grease (µg/L)	Benzene (µg/L)	Toluene (µg/L)	Ethylbenzene (µg/L)	Xylenes (µg/L)	MTBE (µg/L)	
MW-5	4/13/92	ND	.	.	ND	ND	ND	ND	.	
	4/27/92	ND	.	.	ND	ND	ND	ND	.	
	7/9/92	ND	.	.	ND	ND	ND	ND	.	
	10/8/92	ND	.	.	ND	0.40	ND	ND	.	
	1/12/93	ND	.	.	ND	ND	ND	ND	.	
	3/4/93	ND	.	.	ND	ND	ND	ND	.	
	7/1/93	ND	.	.	ND	ND	ND	ND	.	
	10/19/93	ND	.	.	ND	ND	ND	ND	.	
	4/25/94	ND	.	.	ND	0.40	ND	1.0	.	
	07/94	-	.	.	-	-	-	-	.	
	10/13/94	87	ND	ND	ND	36	ND	1.3	.	
	01/95	-	.	.	-	-	-	-	.	
	4/19/95	ND	.	.	ND	ND	ND	ND	.	
	10/12/95	ND	.	.	ND	ND	ND	ND	.	
	4/12/96	ND	.	.	ND	ND	ND	ND	.	
	10/8/96	ND	.	.	ND	ND	ND	ND	ND	
	4/9/97	ND	.	.	ND	ND	ND	ND	ND	
	11/5/97	ND	ND	.	ND	ND	ND	ND	ND	
	3/1/00	ND	.	.	ND	ND	ND	ND	ND	
	09/00	ND	.	.	ND	ND	ND	ND	ND	
	3/22/01	ND	.	.	ND	ND	ND	ND	ND	
	8/23/01	NS	NS	NS	NS	NS	NS	NS	NS	
	03/02	NS	NS	NS	NS	NS	NS	NS	NS	
	10/02	NS	NS	NS	NS	NS	NS	NS	NS	
	03/03	NS	NS	NS	NS	NS	NS	NS	NS	
	9/17/03	NS	NS	NS	NS	NS	NS	NS	NS	
	11/20/08*	<50	<50	.	.	0.31	<0.3	<0.3	0.38	<5.0
	2/6/09*	<50	<50	.	.	<0.3	<0.3	<0.3	<0.3	<5.0

Table 3
Groundwater Monitoring Analytical Results - Petroleum Hydrocarbon Constituents
Former Unocal Service Station
20405 Redwood Road
Castro Valley, California

Well	Date	TPHg (µg/L)	TPHd (µg/L)	Total Oil and Grease (µg/L)	Benzene (µg/L)	Toluene (µg/L)	Ethylbenzene (µg/L)	Xylenes (µg/L)	MTBE (µg/L)
MW-6	4/13/92	ND	.	.	ND	0.30	ND	ND	.
	4/27/92	ND	.	.	ND	ND	ND	ND	.
	7/9/92	ND	.	.	ND	ND	ND	ND	.
	10/8/92	ND	.	.	ND	ND	ND	ND	.
	1/12/93	ND	.	.	ND	ND	ND	ND	.
	3/4/93	ND	.	.	ND	ND	ND	ND	.
	7/1/93	ND	.	.	ND	ND	ND	ND	.
	10/19/93	ND	.	.	ND	ND	ND	ND	.
	4/25/94	ND	.	.	ND	0.30	ND	0.40	.
	07/94	-	.	.	-	-	-	-	.
	10/13/94	160	.	.	0.40	140	0.5	2.3	.
	01/95	-	.	.	-	-	-	-	.
	4/19/95	ND	.	.	ND	ND	ND	ND	.
	10/12/95	ND	.	.	ND	ND	ND	ND	.
	4/12/96	ND	.	.	2.9	2.9	ND	ND	.
	10/8/96	ND	.	.	ND	ND	ND	ND	17
	4/9/97	ND	.	.	ND	ND	ND	ND	ND
	11/5/97	ND	ND	.	ND	ND	ND	ND	9.0
	3/1/00	78	.	.	ND	0.49	ND	ND	260
	09/00	54	.	.	ND	ND	ND	ND	170
	3/22/01	130	.	.	ND	ND	ND	ND	440
	8/23/01	79	.	.	ND	ND	ND	ND	280 ¹ /350
	03/02	91	.	.	ND	ND	ND	ND	370
	10/02	83	.	.	ND	ND	ND	ND	260
	03/03	61	.	.	ND	ND	ND	ND	200
	9/17/03	140	.	.	ND	ND	ND	ND	440
11/20/08*	<50	<50	.	.	0.81	<0.3	<0.3	<0.3	300
2/6/09*	97	<50	.	.	<0.3	<0.3	<0.3	<0.3	200

Table 3
Groundwater Monitoring Analytical Results - Petroleum Hydrocarbon Constituents
Former Unocal Service Station
20405 Redwood Road
Castro Valley, California

Well	Date	TPHg (µg/L)	TPHd (µg/L)	Total Oil and Grease (µg/L)	Benzene (µg/L)	Toluene (µg/L)	Ethylbenzene (µg/L)	Xylenes (µg/L)	MTBE (µg/L)	
MW-7	04/13/92	1,300	-	-	0.40	0.30	0.30	0.9	-	
	4/27/92	1,100	-	-	ND	ND	ND	ND	-	
	7/9/92	830	-	-	ND	ND	ND	ND	-	
	10/8/92	3,900	-	-	ND	ND	ND	ND	-	
	11/30/92	2,700	ND	-	-	-	-	-	-	
	1/12/93	U	U	U	U	U	U	U	U	
	01/93	1,900	-	-	ND	ND	ND	ND	-	
	3/4/93	830	-	-	ND	ND	ND	ND	-	
	7/1/93	680	-	-	ND	ND	ND	ND	-	
	10/19/93	360	-	-	ND	ND	ND	0.70	-	
	1/12/94	330	-	-	ND	ND	ND	ND	-	
	4/25/94	360	-	-	ND	ND	ND	ND	-	
	7/28/94	-	-	-	-	-	-	-	-	
	10/13/94	-	-	-	-	-	-	-	-	
	01/95	-	-	-	-	-	-	-	-	
	4/19/95	-	-	-	ND	ND	ND	ND	ND	
	10/12/95	-	-	-	ND	ND	ND	ND	ND	
	4/12/96	-	-	-	ND	ND	ND	ND	ND	
	10/8/96	-	-	-	-	-	-	-	-	
	4/9/97	-	-	-	-	-	-	-	-	
	11/5/97	-	-	-	-	-	-	-	-	
	3/1/00	ND	-	-	890	ND	ND	ND	ND	ND
	09/00	770	-	-	3.0	0.32	13	27	ND	
	3/22/01	630	-	-	ND	ND	ND	ND	ND	
	8/23/01	800	-	-	ND	ND	ND	ND	7.3 ¹ /ND	
	03/02	280	-	-	0.35	ND	0.91	2.2	7.7	
	10/02	IA	IA	IA	IA	IA	IA	IA	IA	
	03/03	IA	IA	IA	IA	IA	IA	IA	IA	
	9/17/03	IA	IA	IA	IA	IA	IA	IA	IA	
	11/20/08	520	70	-	<0.3	<0.3	<0.3	<0.3	<5.0	
2/6/09*	400	<50	-	<0.3	<0.3	<0.3	<0.3	<5.0		

Table 3
Groundwater Monitoring Analytical Results - Petroleum Hydrocarbon Constituents
Former Unocal Service Station
20405 Redwood Road
Castro Valley, California

Well	Date	TPHg (µg/L)	TPHd (µg/L)	Total Oil and Grease (µg/L)	Benzene (µg/L)	Toluene (µg/L)	Ethylbenzene (µg/L)	Xylenes (µg/L)	MTBE (µg/L)
MW-101	09/95	9,400	-	-	170	94	150	710	-
	03/01/00	40,000	-	-	2,500	490	4,300	10,000	2,400 ¹ /1,400
	09/00	770	-	-	3.0	0.32	13	27	-
	03/01	34,000	-	-	1,400	62	3,400	7,700	970
	08/23/01	12,000	-	-	630	ND	1,500	480	1,400
	03/02	19,000	-	-	600	25	1,600	3,100	1,600 ¹ /870
	10/02	5,200	-	-	240	0.74	230	76	1,500 ¹ /1,400
	03/03	6,300	-	-	330	ND	440	370	1,400 ¹ /840
	9/17/03	3,000	-	-	150	ND	100	110	850 ¹ /1,100
	11/20/08*	2,800	5,400	-	61	<0.3	38	1.6	570
	2/6/09*	<50	3,600	-	<0.3	<0.3	<0.3	<0.3	630
SP-1	11/1993	49,000	-	-	3,900	13,000	2,800	15,000	-
SP-2	11/1993	1,400	-	-	54	240	87	390	-

Notes:

ND: Not detected.

<: Not detected above laboratory's indicated reportable detection limit.

NS: No sample collected.

IA: Well inaccessible at time of sampling.

U: Unavailable.

-: Not analyzed.

*: Other fuel oxygenates and 1,2-DCA not detected above 5 µg/L (50 µg/L for TBA).

¹: MTBE by EPA method 8015/8020; otherwise by EPA Method 8260.

Table 4
Groundwater Monitoring Analytical Results
Volatile Organic Compounds
Former Unocal Service Station
20405 Redwood Road
Castro Valley, California

Well	Date	Chlorobenzene	Chloroform	cis-1,2-Dichloroethene	trans-1,2-Dichloroethene	1,2-Dichloroethane	Tetrachloroethene	Trichloroethene
MW-2	Mar-93	<0.5	<0.5	<0.5	<0.5	0.6	<0.5	<0.5
	10/19/93	<0.5	<0.5	<0.5	<0.5	<0.5	<0.5	<0.5
MW-4	12/14/89	<0.5	<0.5	-	<0.5	<0.5	<0.5	<0.5
	3/4/93	<0.5	<0.5	<0.5	<0.5	<0.5	<0.5	<0.5
	10/19/93	<0.5	<0.5	<0.5	<0.5	<0.5	0.7	0.9
MW-5	3/4/93	<0.5	<0.5	<0.5	<0.5	<0.5	0.8	<0.5
MW-6	3/4/93	<0.5	<0.5	<0.5	<0.5	<0.5	3.5	<0.5
MW-7	11/30/92	2.0	2.0	180	1.5	-	14,000	660
	3/4/93	-	<20	-	<20	<20	3,700	210
SP-1	11/18/93	unknown	unknown	28	15	12	22	20
SP-2	11/18/93	unknown	unknown	ND	ND	ND	ND	ND

Notes:
<: Not detected above laboratory's indicated reportable detection limit.
-: Not analyzed

Table 5
Summary of Groundwater Elevation Data
Former Unocal Service Station
20405 Redwood Road
Castro Valley, California

Well	Date Measured	Casing Elevation (Feet above MSL)	Depth to Groundwater (Feet)	Groundwater Elevation (Feet above MSL)
MW-101	09/95	U	U	-
	3/1/00		9.75	-
	09/00		U	-
	03/01		U	-
	08/23/01		9.70	-
	03/02		U	-
	10/02		U	-
	03/03		U	-
	9/17/03		9.80	-
	11/20/08		10.69	-
2/6/09	10.46	-		

Table 5
Summary of Groundwater Elevation Data
Former Unocal Service Station
20405 Redwood Road
Castro Valley, California

Well	Date Measured	Casing Elevation (Feet above MSL)	Depth to Groundwater (Feet)	Groundwater Elevation (Feet above MSL)
MW-2	12/89	U	U	-
	08/90		U	-
	01/91		U	-
	04/91		U	-
	07/91		U	-
	10/91		U	-
	01/92		U	-
	4/20/92	183.10	10.36	172.74
	7/9/92		10.65	172.45
	10/8/92	183.47	11.60	171.87
	1/12/93		9.11	174.36
	3/4/93		9.28	174.19
	7/1/93		10.37	173.10
	10/19/93		10.82	172.65
	1/12/94		10.66	172.81
	4/25/94		10.23	173.24
	7/28/94		10.70	172.77
	10/13/94		14.19	169.28
	1/10/95		8.12	175.35
	4/19/95		9.24	174.23
	10/12/95		10.66	172.81
	4/12/96		10.05	173.42
	10/8/96		10.61	172.86
	4/9/97		10.40	173.07
	11/5/97		10.88	172.59
	3/1/00		8.49	174.98
	09/00		U	-
3/22/01		9.65	173.82	
8/23/01		9.65	173.82	
03/2002		U	-	
10/2002		U	-	
03/2003		IA	-	
9/17/03		IA	-	
11/20/08		IA	-	
2/11/09		U	-	

Table 5
Summary of Groundwater Elevation Data
Former Unocal Service Station
20405 Redwood Road
Castro Valley, California

Well	Date Measured	Casing Elevation (Feet above MSL)	Depth to Groundwater (Feet)	Groundwater Elevation (Feet above MSL)
MW-3	12/89	U	U	-
	08/90		U	-
	01/91		U	-
	04/91		U	-
	07/91		U	-
	10/91		U	-
	01/92		U	-
	4/20/92	183.52	10.34	173.18
	7/9/92		10.84	172.68
	10/8/92	184.03	11.96	172.07
	1/12/93		9.28	174.75
	3/4/93		9.53	174.50
	7/1/93		10.56	173.47
	10/19/93		11.04	172.99
	1/12/94		10.90	173.13
	4/25/94		10.37	173.66
	7/28/94		10.95	173.08
	10/13/94		14.37	169.66
	1/10/95		8.23	175.80
	4/19/95		9.54	174.49
	10/12/95		10.97	173.06
	4/12/96		10.06	173.97
	10/8/96		10.87	173.16
	4/9/97		10.40	173.63
	11/5/97		10.97	173.06
	3/1/00		8.68	175.35
	09/00		U	-
3/22/01		10.22	173.81	
8/23/01		10.02	174.01	
03/02		U	-	
10/02		U	-	
03/03		U	-	
9/17/03		10.00	174.03	
11/20/08		IA	-	
2/11/09		U	-	

Table 5
Summary of Groundwater Elevation Data
Former Unocal Service Station
20405 Redwood Road
Castro Valley, California

Well	Date Measured	Casing Elevation (Feet above MSL)	Depth to Groundwater (Feet)	Groundwater Elevation (Feet above MSL)
MW-4	12/89	U	U	-
	08/90		U	-
	01/91		U	-
	04/91		U	-
	07/91		U	-
	10/91		U	-
	01/92		U	-
	4/20/92		10.89	
	7/9/92	184.33	10.65	173.68
	10/8/92	184.61	12.78	171.83
	1/12/93		9.67	174.94
	3/4/93		10.20	174.41
	7/1/93		11.41	173.20
	10/19/93		11.92	172.69
	4/25/94		10.94	173.67
	7/28/94		11.74	172.87
	10/13/94		15.31	169.30
	1/10/95		8.02	176.59
	4/19/95		9.97	174.64
	10/12/95		11.70	172.91
4/12/96		10.33	174.28	
10/8/96		11.65	172.96	
4/9/97		10.93	173.68	
11/5/97		11.82	172.79	

Table 5
Summary of Groundwater Elevation Data
Former Unocal Service Station
20405 Redwood Road
Castro Valley, California

Well	Date Measured	Casing Elevation (Feet above MSL)	Depth to Groundwater (Feet)	Groundwater Elevation (Feet above MSL)
MW-5	4/27/92	183.62	11.72	171.90
	7/9/92		12.24	171.38
	10/8/92	183.92	13.24	170.68
	1/12/93		10.30	173.62
	3/4/93		10.53	173.39
	7/1/93		11.85	172.07
	10/19/93		12.32	171.60
	4/25/94		11.58	172.34
	07/94		U	-
	10/13/94		15.71	168.21
	01/95		U	-
	4/19/95		10.41	173.51
	10/12/95		12.12	171.80
	4/12/96		10.85	173.07
	10/8/96		12.00	171.92
	4/9/97		11.40	172.52
	11/5/97		12.19	171.73
	3/1/00		9.45	174.47
	09/00		U	-
	3/22/01		11.04	172.88
	8/23/01		11.06	172.86
	03/02		NS	-
	10/02		NS	-
	03/03		NS	-
	9/17/03		11.03	172.89
	11/20/08		11.80	172.12
	2/6/09		11.56	172.36

Table 5
Summary of Groundwater Elevation Data
Former Unocal Service Station
20405 Redwood Road
Castro Valley, California

Well	Date Measured	Casing Elevation (Feet above MSL)	Depth to Groundwater (Feet)	Groundwater Elevation (Feet above MSL)
MW-6	4/27/92	U	11.90	171.80
	7/9/92	183.70	12.34	171.36
	10/8/92	183.96	13.3	170.66
	1/12/93	183.60	10.59	173.01
	3/4/93		10.86	172.74
	7/1/93		12.00	171.60
	10/19/93		12.48	171.12
	4/25/94		11.86	171.74
	07/94		U	-
	10/13/94		15.87	167.73
	01/95		U	-
	4/19/95		10.70	172.90
	10/12/95		12.32	171.28
	4/12/96		11.09	172.51
	10/8/96		12.19	171.41
	4/9/97		11.70	171.90
	11/5/97		12.33	171.27
	3/1/00		9.73	173.87
	09/00		U	-
	3/22/01		11.01	172.59
	8/23/01		11.21	172.39
	03/02		U	-
	10/02		U	-
03/03		U	-	
9/17/03		11.50	172.10	
11/20/08		12.10	171.50	
2/6/09		11.83	171.77	

Table 5
Summary of Groundwater Elevation Data
Former Unocal Service Station
20405 Redwood Road
Castro Valley, California

Well	Date Measured	Casing Elevation (Feet above MSL)	Depth to Groundwater (Feet)	Groundwater Elevation (Feet above MSL)
MW-7	4/27/92	182.52	10.97	171.55
	7/9/92		11.43	171.09
	10/8/92	182.78	12.40	170.38
	11/30/92		12.00	170.78
	1/12/93		9.51	173.27
	01/93		U	-
	3/4/93		9.88	172.90
	7/1/93		11.07	171.71
	10/19/93		11.55	171.23
	1/12/94	182.42	11.36	171.06
	4/25/94		10.85	171.57
	7/28/94		NS	-
	10/13/94		NS	-
	01/95		U	-
	4/19/95		9.66	172.76
	10/12/95		11.34	171.08
	4/12/96		10.06	172.36
	10/8/96		11.16	171.26
	4/9/97		11.70	170.72
	11/5/97		11.36	171.06
	3/1/00		8.72	173.70
	09/00		U	-
	3/22/01		10.04	172.38
	8/23/01		10.18	172.24
	03/02		U	-
	10/02		IA	-
	03/03		IA	-
9/17/03	IA		-	
11/20/08	11.05		171.37	
2/6/09	10.76	171.66		

Notes:
IA: Well Inaccessible
NS: Well Not Sampled
U: Data Unavailable
-: Unable to calculate elevation

Table 6
Summary of Groundwater Flow Direction and Gradient Data
Former Unocal Service Station
20405 Redwood Road
Castro Valley, California

Date	Flow Direction	Gradient (Feet/Foot)
11/1/1992	Southeast	0.006
1/27/1993	Southeast	0.010
3/4/1993	Southeast	0.012
7/1/1993	Southeast	0.012
10/19/1993	South	0.005
1/12/1994	South	0.001
5/13/1994	Southwest	0.007
10/13/1994	South	0.001
1/31/1995	South	0.002
5/17/1995	South	0.009
10/30/1995	South	0.007
4/12/1996	South	0.008
11/5/1996	South	0.008
4/9/1997	South	0.010
8/23/2001	South	0.008
9/17/2003	Southeast	0.012
11/20/2008	Southeast	0.010
2/5/2009	South-southeast	0.010



TN / MN
15°

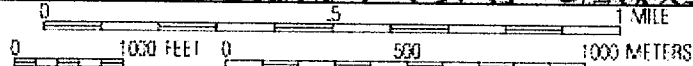

Map created with TOPO!® ©2003 National Geographic (www.nationalgeographic.com/topo)

BSK
Associates
Engineers/Laboratories

SITE VICINITY
FORMER UNOCAL SERVICE STATION
20405 REDWOOD ROAD
CASTRO VALLEY, CALIFORNIA

FIGURE 1

PROJECT: E0805401S

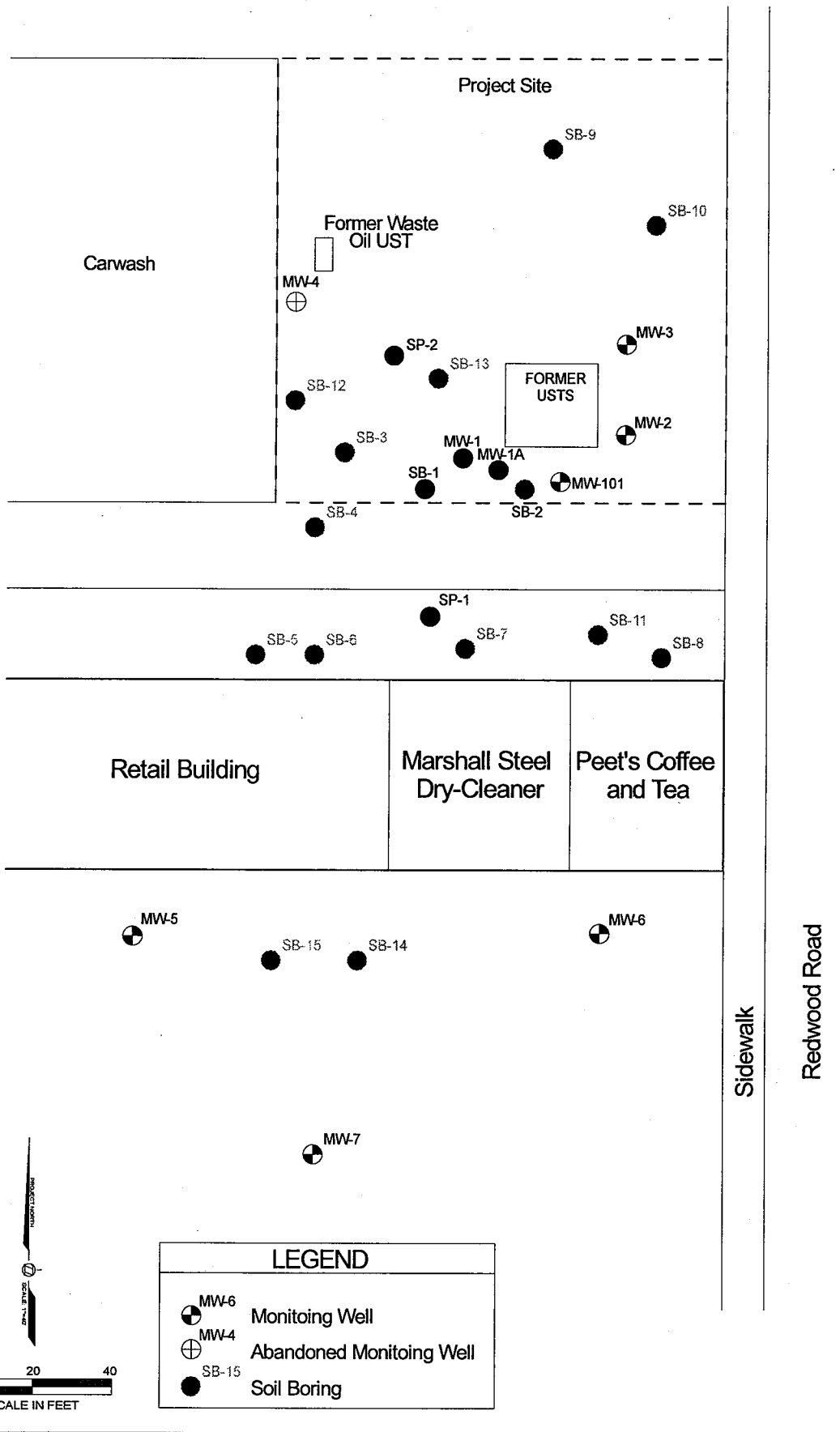

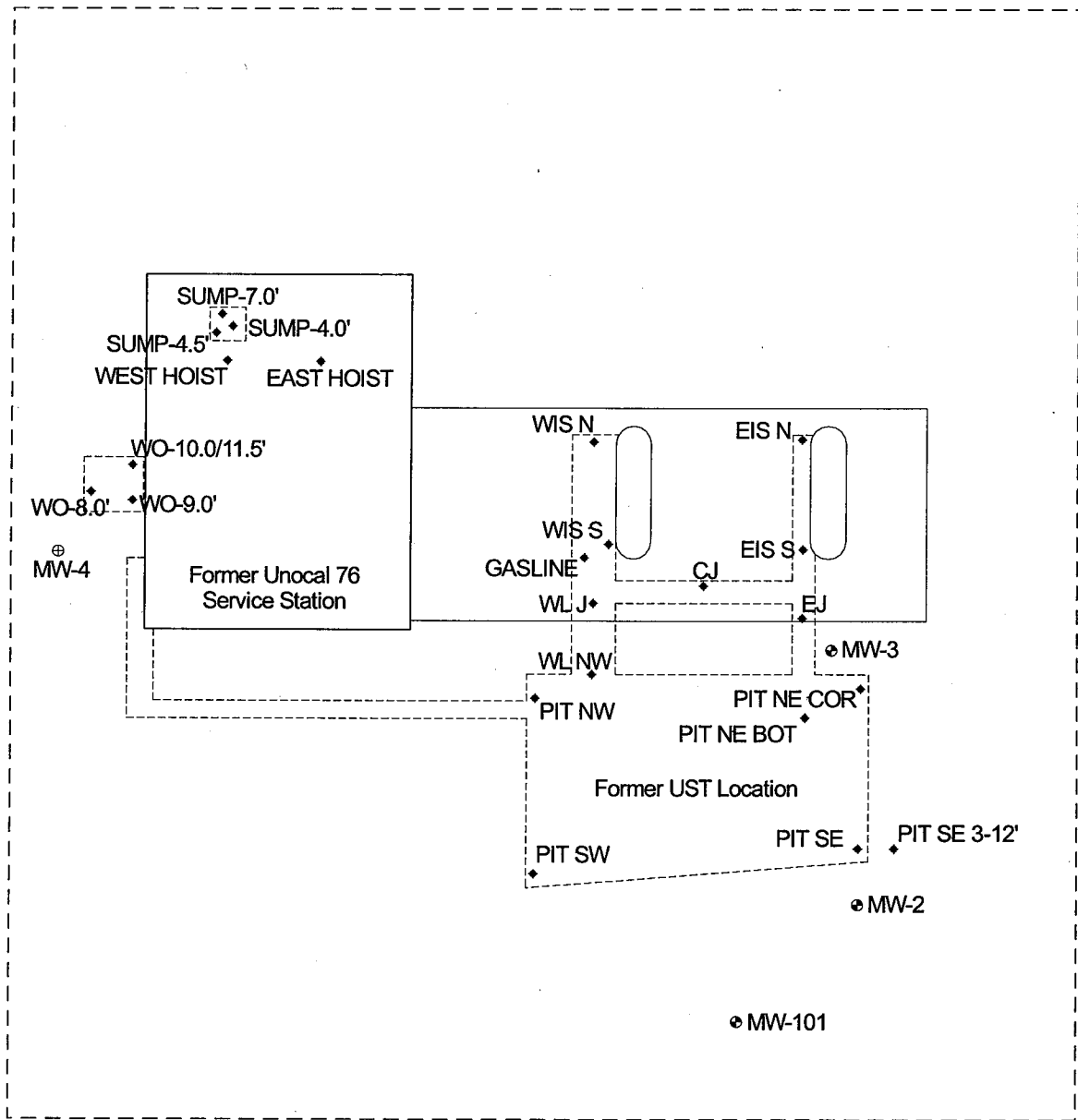

Redwood Road

← Driveway to Shopping Center

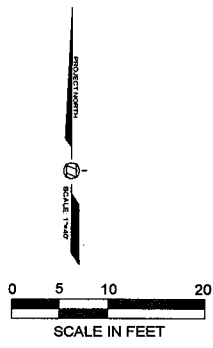

LEGEND	
◆	Soil Sample Location
⊔	Approximate Extent of Excavation
●	Monitoring Well Location
⊕	Abandoned Monitoring Well Location



EXTENT OF EXCAVATIONS AND
EXCAVATION SOIL SAMPLE LOCATIONS
FORMER UNOCAL SERVICE STATION
20405 REDWOOD ROAD
CASTRO VALLEY, CALIFORNIA

FIGURE 3
PROJECT: E0805401S
DATE: 2/12/09

Groundwater Flow Direction

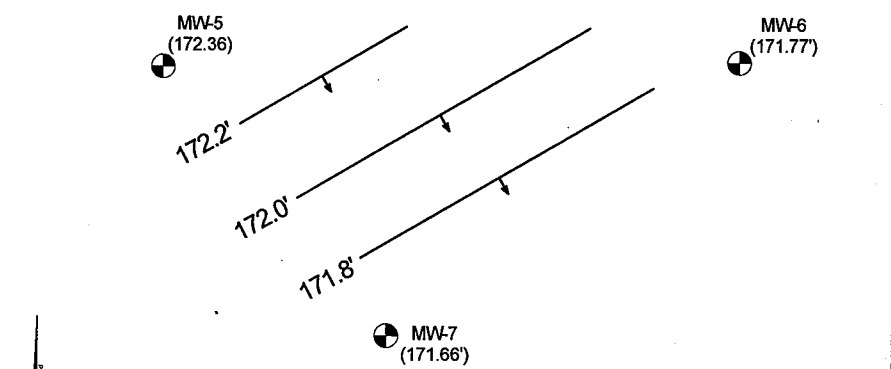
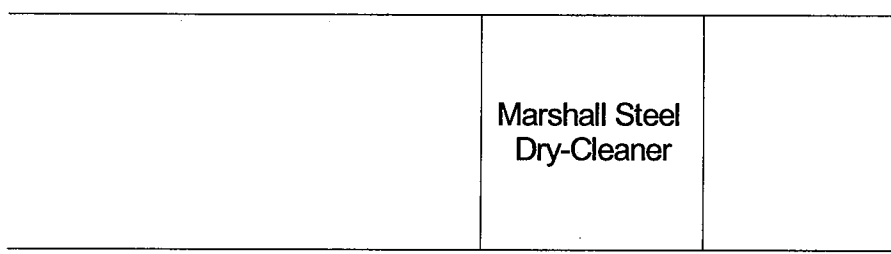
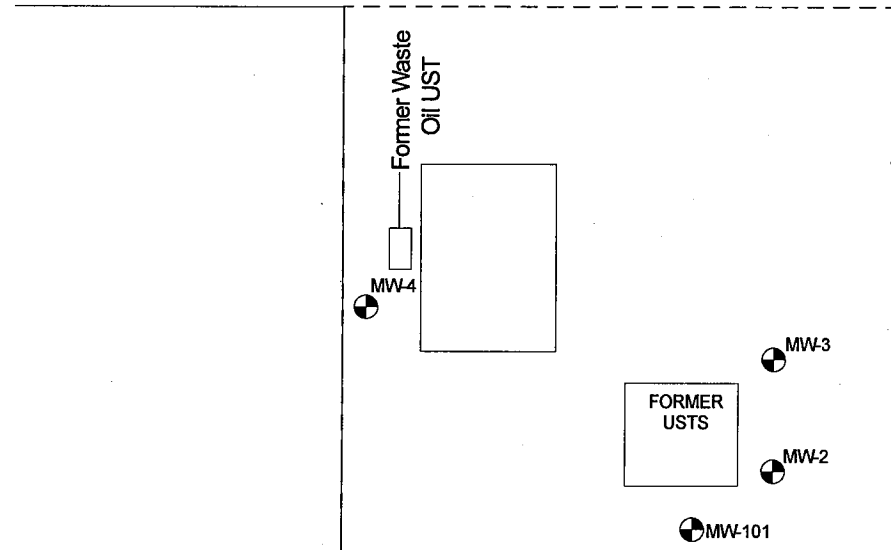
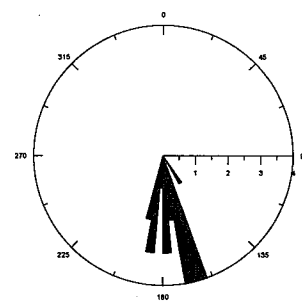

Sidewalk

Redwood Road



LEGEND	
	Generalized Groundwater Contour Line
	Monitoring Well (Groundwater Elevation, feet above MSL)

BSK
Associates
Engineers & Laboratories

GENERALIZED GROUNDWATER ELEVATION MAP
FEBRUARY 2009
FORMER UNOCAL SERVICE STATION
20405 REDWOOD ROAD
CASTRO VALLEY, CALIFORNIA

FIGURE 4
PROJECT: E0805401S
DATE: 4/13/09

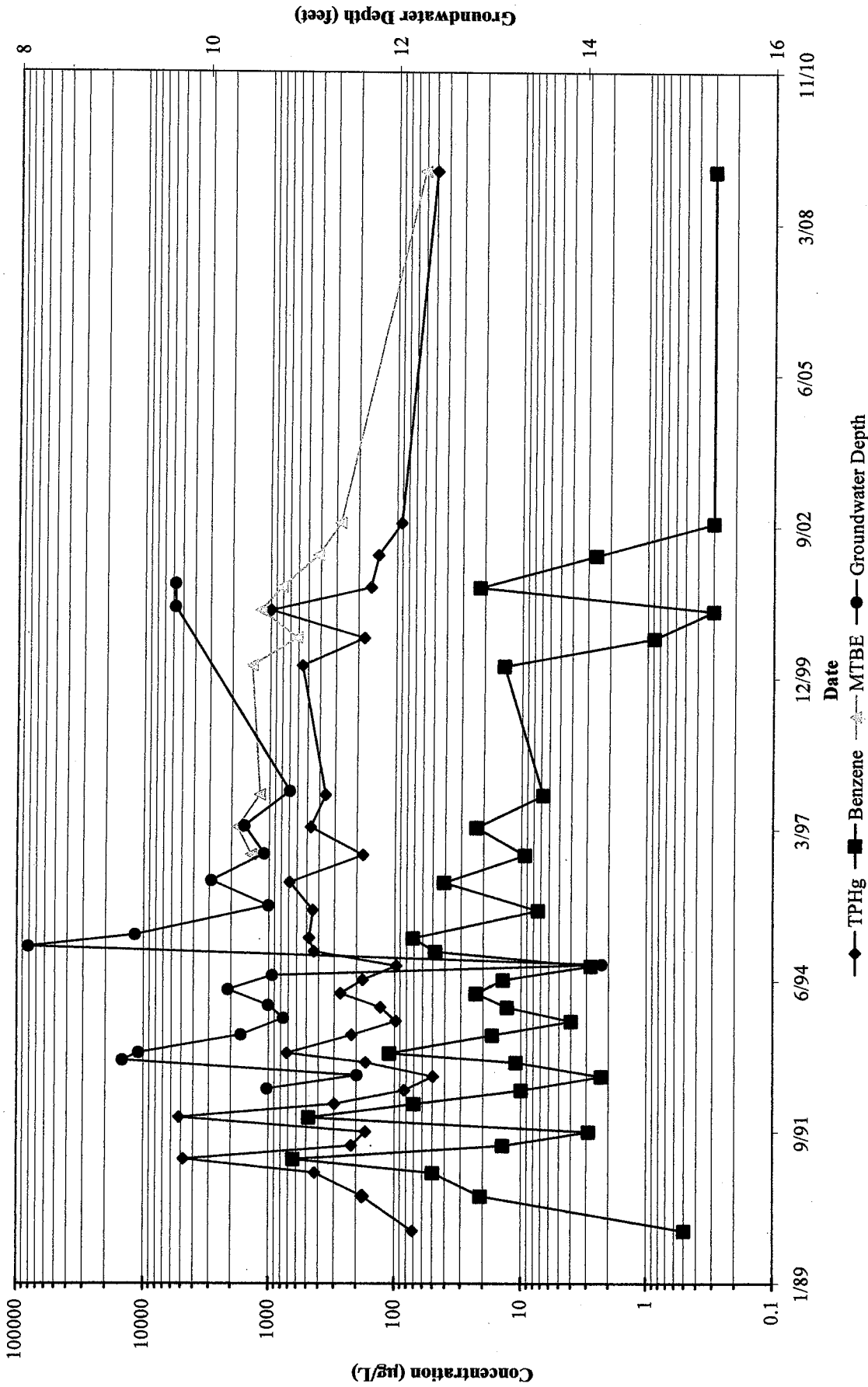

Non-detects plotted as 1/2 of the reportable detection limits (typically 50 µg/L for TPH, 0.3 µg/L for Benzene, and 5 µg/L for MTBE).

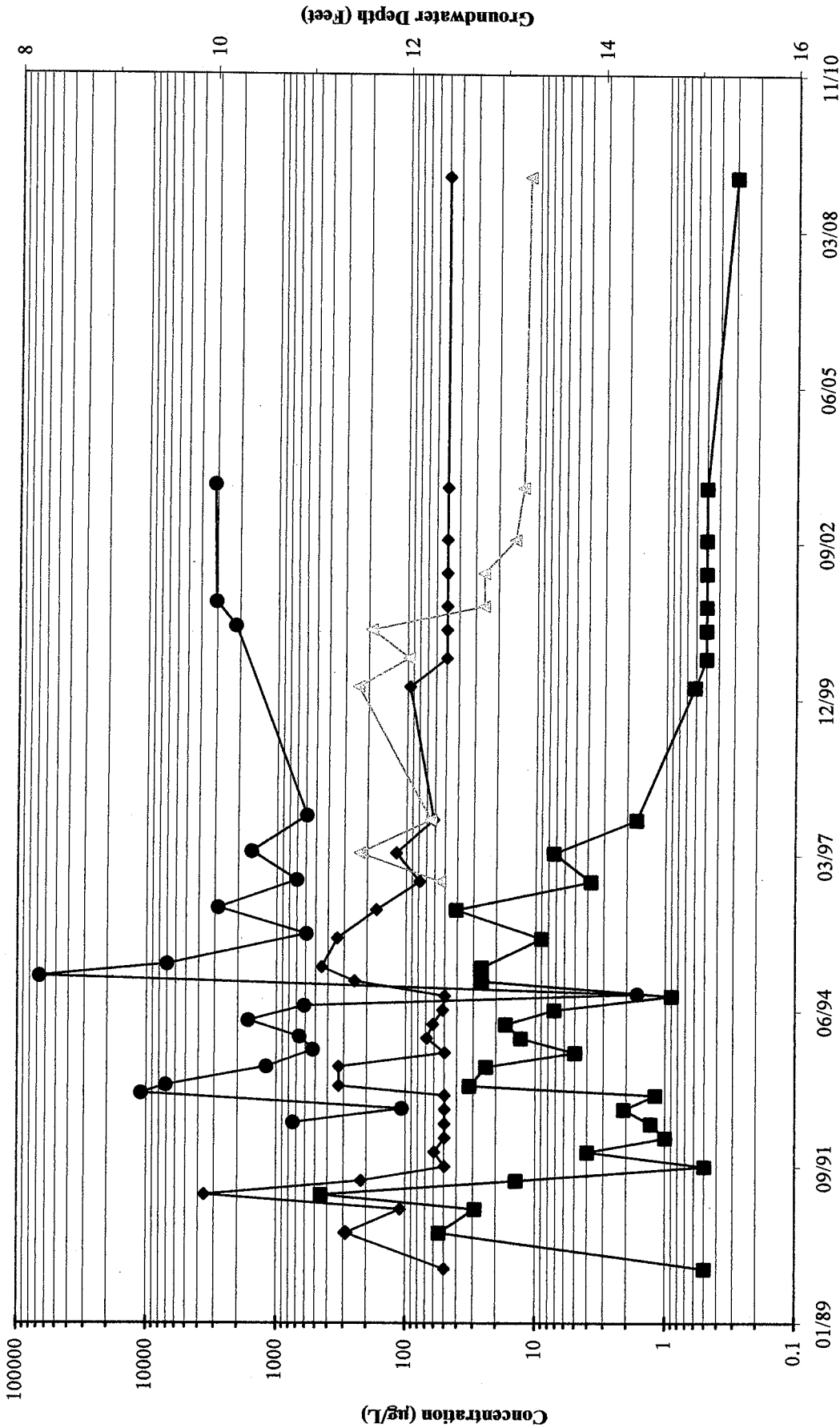

Legend:
 ◆—TPHg
 ■—Benzene
 ▲—MTBE
 ●—Groundwater Depth

Non-detects plotted as 1/2 of the reportable detection limits (typically 50 µg/L for TPHg, 0.3 µg/L for Benzene, and 5 µg/L for MTBE).



MW-3 TIME-SERIES PLOTS
 FORMER UNOCAL SERVICE STATION
 20405 REDWOOD ROAD
 CASTRO VALLEY, CALIFORNIA

FIGURE 6

PROJECT: E0503102S

DATE: 4/13/09

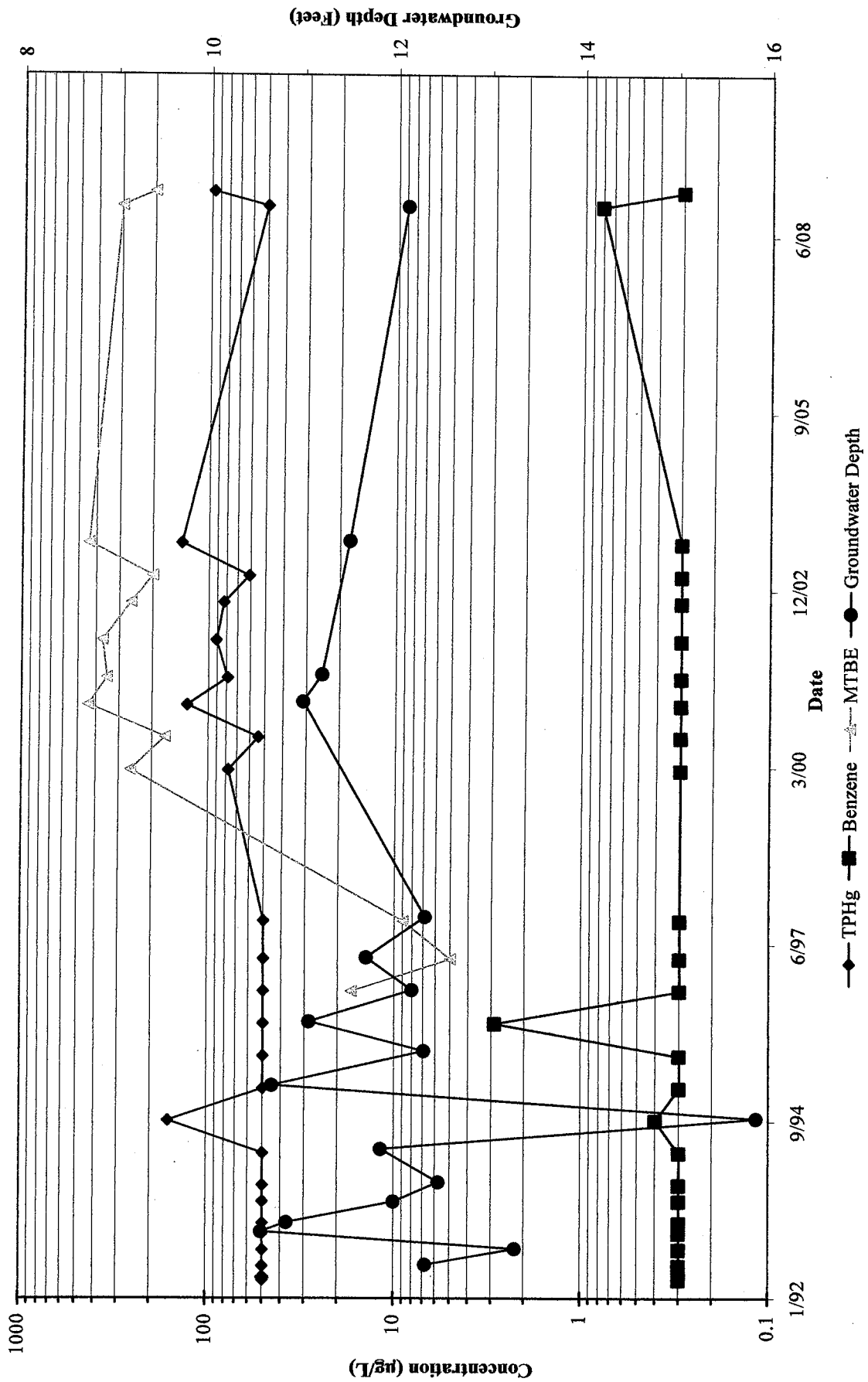

Non-detects plotted as 1/2 of the reportable detection limits (typically 50 µg/L for TPH, 0.3 µg/L for Benzene, and 5 µg/L for MTBE).



MW-6 TIME-SERIES PLOTS
 FORMER UNOCAL SERVICE STATION
 20405 REDWOOD ROAD
 CASTRO VALLEY, CALIFORNIA

FIGURE 7

PROJECT: E0503102S

DATE: 4/13/09

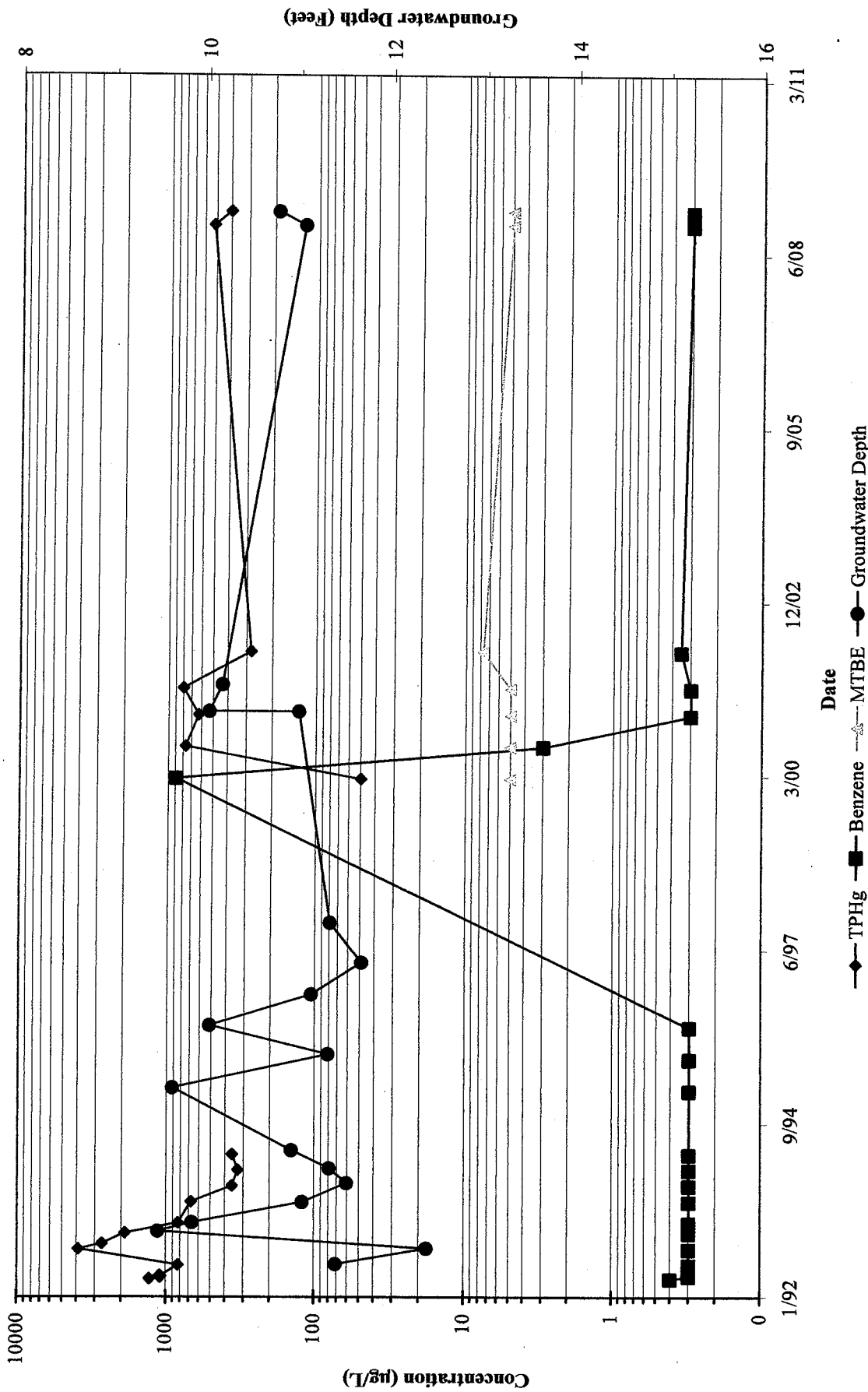

Non-detects plotted as 1/2 of the reportable detection limits (typically 50 µg/L for TPH, 0.3 µg/L for Benzene, and 5 µg/L for MTBE).



MW-7 TIME-SERIES PLOTS
 FORMER UNOCAL SERVICE STATION
 20405 REDWOOD ROAD
 CASTRO VALLEY, CALIFORNIA

FIGURE 8

PROJECT: E0503102S

DATE: 4/13/09

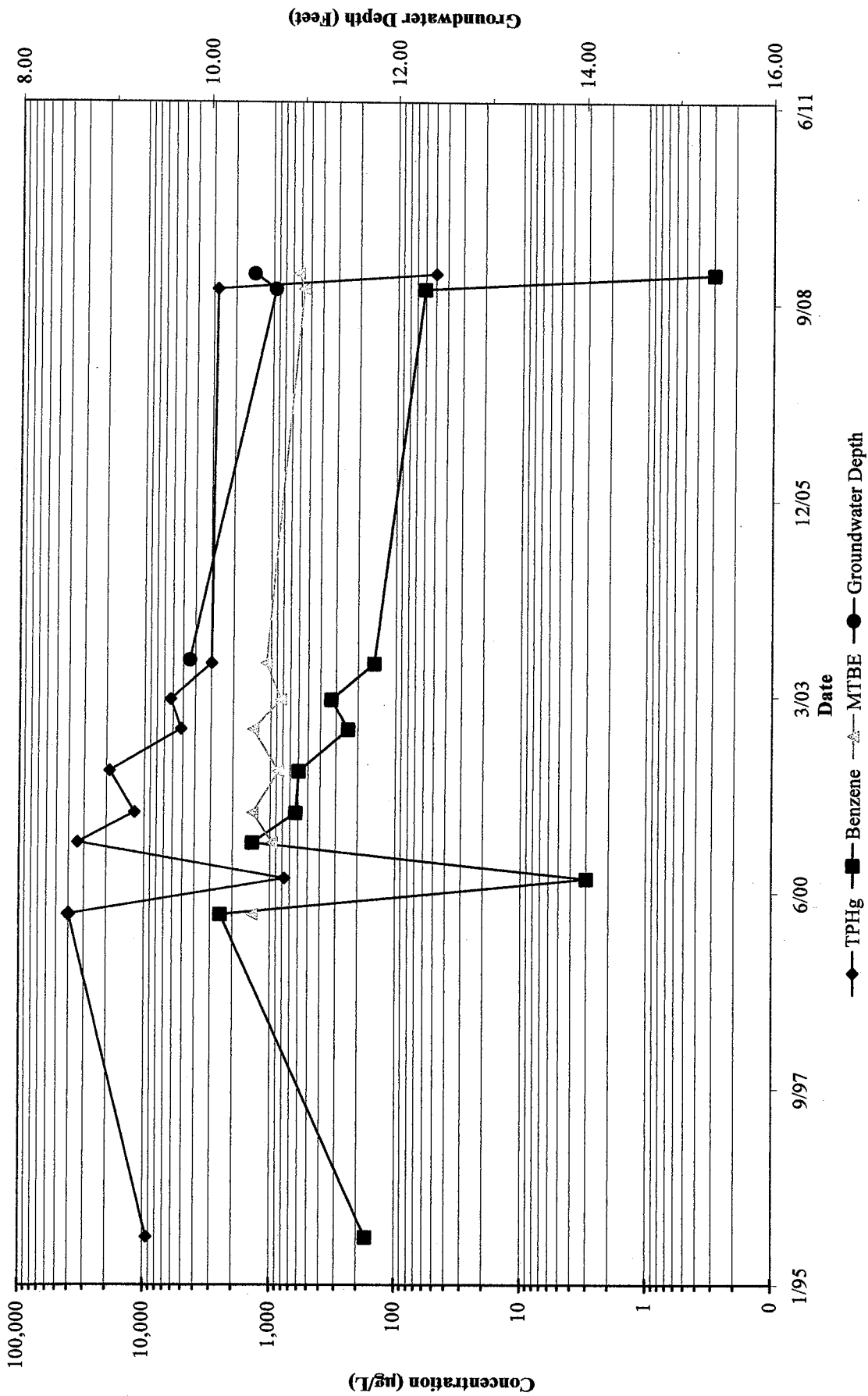

Non-detects plotted as 1/2 of the reportable detection limits (typically 50 µg/L for TPH, 0.3 µg/L for Benzene, and 5 µg/L for MTBE).



MW-101 TIME-SERIES PLOTS
 FORMER UNOCAL SERVICE STATION
 20405 REDWOOD ROAD
 CASTRO VALLEY, CALIFORNIA

FIGURE 9

PROJECT: E0503102S

DATE: 4/13/09

APPENDIX A

Water Sample Logs

WELL SAMPLE LOG

Project Name: <u>UNOCAL CASTRO VALLEY</u>	Job #: <u>E08054015</u>	Field Personnel: <u>D. CUELLAR</u>
Day: Mon Tu Wed <u>Thur</u> Fri Sat Sun (Circle)	Date: <u>02-05-09</u>	Weather: Clear <u>Partly Cloudy</u> Overcast Rain (Circle) Cold <u>Cool</u> Warm Hot Very Hot

Well: <u>MW-101</u>	Water Level Measurement Technique: <input checked="" type="checkbox"/> Electric Sounder <input type="checkbox"/> Not Measured
Static Depth to Water (Ft.) (A) ¹⁾ <u>10.46</u> ²⁾	Purge Method: <u>Grundfos Submersible Pump</u> Pneumatic Pump (Circle) Electric Pump Hand Bailed
Total Depth of Casing (Ft.) (B) <u>29.57</u>	
Total Ft. of Water (B-A) <u>19.11</u>	Dedicated System: Yes <input type="checkbox"/> <u>No</u> <input checked="" type="checkbox"/>
Casing Diameter (in.) <u>4" 3/4"</u>	pH Calibration: <input checked="" type="checkbox"/> 4.0 <input checked="" type="checkbox"/> 7.0 <input type="checkbox"/> 10.0
Casing Capacity-gal/ft (C) <u>0.653 @ 163</u>	EC Calibration(μmhos) <u>1413</u>
Gallons per Casing Volume [(B-A)*C] <u>12.48</u>	

Time	Gallons Purged	PH	EC (μmhos)	Temp (°F)/(°C)	Other	Remarks (Color, Odor, Turbidity, etc.)
1456						
1500	13	6.92	768	19.7		mostly clear, strong odor
1531	26	6.90	787	20.2		clear, strong hydro c odor
1604	39	6.72	782	19.7		clear, strong hydro c odor

Purge Pump On	Discharge Measurement: (Circle) <u>Bucket</u> Tank Flowmeter
Purge Pump Off	Sample Collection Method: <input type="checkbox"/> Direct From Discharge Hose
Total Gallons Purged	<input type="checkbox"/> Teflon Bailor <input checked="" type="checkbox"/> Disposable Bailor
Purge Rate (gpm)	Ice Chest Coolant: <input type="checkbox"/> Crushed Ice <input checked="" type="checkbox"/> Blue Ice Ice Chest Temp (°C) _____

Sample Time	Analyses	Amount/Container Used	Sample Description
1625		6-40ml VOA's w/ HCl 1-500ml amber w/ H ₂ SO ₄	

Well Vault Type: <u>FLUSH MOUNT</u>	Floating Product: <input type="checkbox"/> Yes <input checked="" type="checkbox"/> No <input type="checkbox"/> NA
Lock Number/Type:	Thickness: _____
Drums Filled/Used:	Description: _____

WELL SAMPLE LOG

Project Name: <u>UNOCAL CASTRO VALLEY</u>	Job #: <u>E08054015</u>	Field Personnel: <u>D. CUELLAR</u>
Day: Mon Tu Wed <u>Thur</u> Fri Sat Sun (Circle)	Date: <u>02-05-09</u>	Weather: Clear <u>Partly Cloudy</u> Overcast Rain (Circle) Cold <u>Cool</u> Warm Hot Very Hot

Well: <u>MW-5</u>	Water Level Measurement Technique: <input checked="" type="checkbox"/> Electric Sounder <input type="checkbox"/> Not Measured
Static Depth to Water (Ft.) (A) ¹⁾ <u>11.56</u> ²⁾	Purge Method: <u>Grundfos Submersible Pump</u> Pneumatic Pump (Circle) Electric Pump Hand Bailed Other _____
Total Depth of Casing (Ft.) (B) <u>34.30</u>	
Total Ft. of Water (B-A) <u>22.74</u>	Dedicated System: Yes <input type="checkbox"/> <u>No</u>
Casing Diameter (in.) <u>2"</u>	pH Calibration: <input checked="" type="checkbox"/> 4.0 <input checked="" type="checkbox"/> 7.0 <input type="checkbox"/> 10.0
Casing Capacity-gal/ft (C) <u>0.163</u>	EC Calibration(µmhos) <u>1413</u>
Gallons per Casing Volume [(B-A)*C] <u>3.71</u>	

Time	Gallons Purged	PH	EC (µmhos)	Temp (°F)/(°C)	Other	Remarks (Color, Odor, Turbidity, etc.)
<u>1144</u>						
<u>1146</u>	<u>4</u>	<u>5.92</u>	<u>604</u>	<u>18.7</u>		<u>Mostly clear</u>
<u>1147</u>	<u>8</u>	<u>5.92</u>	<u>578</u>	<u>19.4</u>		<u>11 11</u>
<u>1148</u>	<u>12</u>	<u>6.04</u>	<u>575</u>	<u>20.0</u>		<u>11 11</u>

Purge Pump On	<u>1144</u>	Discharge Measurement: (Circle) <u>Bucket</u> Tank Flowmeter
Purge Pump Off	<u>1148</u>	Sample Collection Method: <input type="checkbox"/> Direct From Discharge Hose <input type="checkbox"/> Teflon Bailer <input checked="" type="checkbox"/> Disposable Bailer
Total Gallons Purged	<u>12</u>	
Purge Rate (gpm)	<u>3.0</u>	Ice Chest Coolant: <input type="checkbox"/> Crushed Ice <input checked="" type="checkbox"/> Blue Ice Ice Chest Temp (°C) _____

Sample Time	Analyses	Amount/Container Used	Sample Description
<u>1205</u>		<u>6-40ml VOA's w/ HCl</u>	
		<u>1-500ml amber w/ H₂SO₄</u>	

Well Vault Type:	<u>FLUSH MOUNT</u>	Floating Product: <input type="checkbox"/> Yes <input checked="" type="checkbox"/> No <input type="checkbox"/> NA
Lock Number/Type:		Thickness: _____
Drums Filled/Used:		Description: _____

WELL SAMPLE LOG

Project Name: UNOCAL CASTRO VALLEY	Job #: E08054015	Field Personnel: D. CUELLAR
Day: Mon Tu Wed Thur Fri Sat Sun (Circle)	Date: 02-05-09	Weather: Clear Partly Cloudy Overcast Rain (Circle) Cold Cool Warm Hot Very Hot

Well: MW-6	Water Level Measurement Technique: <input checked="" type="checkbox"/> Electric Sounder <input type="checkbox"/> Not Measured
Static Depth to Water (Ft.) (A) ¹⁾ 11.93 ²⁾	Purge Method: Grundfos Submersible Pump Pneumatic Pump (Circle) Electric Pump Hand Bailed Other _____
Total Depth of Casing (Ft.) (B) 26.85	
Total Ft. of Water (B-A) 15.02	Dedicated System: Yes <input type="checkbox"/> No <input checked="" type="checkbox"/>
Casing Diameter (in.) 2 1/2	pH Calibration: <input checked="" type="checkbox"/> 4.0 <input checked="" type="checkbox"/> 7.0 <input type="checkbox"/> 10.0
Casing Capacity-gal/ft (C) 0.163	EC Calibration(µmhos) 1413
Gallons per Casing Volume ((B-A)*C) 2.45	

Time	Gallons Purged	PH	EC (µmhos)	Temp (°F)/(°C)	Other	Remarks (Color, Odor, Turbidity, etc.)
1236						
1245	2.5	6.78	695	20.5		lt brown, light turbidity
1254	5.0	6.78	726	19.8		" "
1303	7.5	6.79	731	19.7		" "

Purge Pump On	Discharge Measurement: (Circle) Bucket Tank Flowmeter
Purge Pump Off	Sample Collection Method: <input type="checkbox"/> Direct From Discharge Hose <input type="checkbox"/> Teflon Bailer <input checked="" type="checkbox"/> Disposable Bailer
Total Gallons Purged	
Purge Rate (gpm)	Ice Chest Coolant: <input type="checkbox"/> Crushed Ice <input checked="" type="checkbox"/> Blue Ice Ice Chest Temp (°C) _____

Sample Time	Analyses	Amount/Container Used	Sample Description
1310		6-40ml VOA w/ HCl 1-500ml amber w/ H ₂ SO ₄	

Well Vault Type: FLUSH MOUNT	Floating Product: <input type="checkbox"/> Yes <input checked="" type="checkbox"/> No <input type="checkbox"/> NA
Lock Number/Type:	Thickness: _____
Drums Filled/Used:	Description: _____

WELL SAMPLE LOG

Project Name: <u>VINOCA CASTRO VALLEY</u>	Job #: <u>E08054015</u>	Field Personnel: <u>D. CUELLAR</u>
Day: Mon Tu Wed <u>Thur</u> Fri Sat Sun (Circle)	Date: <u>02-05-09</u>	Weather: Clear <u>Partly Cloudy</u> Overcast Rain (Circle) Cold <u>Cool</u> Warm Hot Very Hot

Well: <u>MW-7</u>	Water Level Measurement Technique: <input checked="" type="checkbox"/> Electric Sounder <input type="checkbox"/> Not Measured	
Static Depth to Water (Ft.) (A) ¹⁾ <u>10.76</u> ²⁾	Purge Method: Grundfos Submersible Pump Pneumatic Pump (Circle) Electric Pump <u>Hand Bailed</u> Other _____	
Total Depth of Casing (Ft.) (B) <u>28.00</u>		
Total Ft. of Water (B-A) <u>17.24</u>		
Casing Diameter (in.) <u>2"</u>	Dedicated System: <input checked="" type="checkbox"/> Yes <input checked="" type="checkbox"/> No	
Casing Capacity-gal/ft (C) <u>0.163</u>	pH Calibration: <input checked="" type="checkbox"/> 4.0 <input checked="" type="checkbox"/> 7.0 <input type="checkbox"/> 10.0	
Gallons per Casing Volume ((B-A)*C) <u>2.81</u>	EC Calibration(µmhos) <u>1413</u>	

Time	Gallons Purged	PH	EC (µmhos)	Temp (°F)/(°C)	Other	Remarks (Color, Odor, Turbidity, etc.)
<u>1335</u>						
<u>1344</u>	<u>3</u>	<u>6.94</u>	<u>624</u>	<u>20.2</u>		<u>Faint gray, very slightly turbid</u>
<u>1352</u>	<u>6</u>	<u>6.84</u>	<u>656</u>	<u>19.6</u>		<u>" "</u>
<u>1400</u>	<u>9</u>	<u>6.90</u>	<u>634</u>	<u>19.7</u>		<u>" "</u>

Purge Pump On	Discharge Measurement: (Circle) <u>Bucket</u> Tank Flowmeter
Purge Pump Off	Sample Collection Method: <input type="checkbox"/> Direct From Discharge Hose <input type="checkbox"/> Teflon Bailer <input checked="" type="checkbox"/> Disposable Bailer
Total Gallons Purged	
Purge Rate (gpm)	Ice Chest Coolant: <input type="checkbox"/> Crushed Ice <input checked="" type="checkbox"/> Blue Ice Ice Chest Temp (°C) _____

Sample Time	Analyses	Amount/Container Used	Sample Description
<u>1410</u>		<u>6-40ml VOAS w/ HCl</u>	
		<u>1-500ml amber w/ H2SO4</u>	

Well Vault Type: <u>FLUSH MOUNT</u>	Floating Product: <input type="checkbox"/> Yes <input checked="" type="checkbox"/> No <input type="checkbox"/> NA
Lock Number/Type:	Thickness: _____
Drums Filled/Used:	Description: _____

APPENDIX B

*Laboratory Reports
Groundwater Samples*

Jeff Yeazell
BSK Associates - Sacramento
3140 Gold Camp Drive Suite 160
Rancho Cordova, CA 95670

02/20/2009

Dear Jeff Yeazell,

Thank you for selecting BSK Analytical Laboratories for your analytical testing needs. We have prepared this report in response to your request for analytical services. Please find enclosed the following sections for your complete laboratory report, each uniquely paginated:

CASE NARRATIVE: An overview of the work performed.

CERTIFICATE OF ANALYSIS: Analytical results.

QUALITY CONTROL (QC) SUMMARY: QC supporting the results presented herein.

REPORT OF SAMPLE INTEGRITY

CHAIN OF CUSTODY FORM

Certification: BSK Analytical Laboratories certifies that the test results contained in this report meet all requirements of the NELAC Standards for applicable certified drinking water chemistry analyses under CA NELAP Certificate #04227CA, CA-ELAP Certificate #1180, and Nevada Certificate #CA79. For all other matrices and bacteriological analyses, this data package is in compliance with ELAP Standards for applicable certified analyses under CA-ELAP Certificate #1180. Any exceptions to applicable standards have been noted in the case narrative. Please note that certifications are applicable only to tests and/or analytes specified on each. Certification information may be obtained by contacting the laboratory or visiting our website at www.bsklabs.com. The results in this report pertain only to the samples tested in the laboratory. This report shall not be reproduced, except in full, without written permission from BSK Analytical Laboratories.

If additional clarification of any information is required, please contact your Client Services Representative, Dan Larkin, at (800) 877-8310 or (559) 497-2888.

BSK ANALYTICAL LABORATORIES



Dan Larkin

Client Services Representative



Quality Control Reviewer



SAMPLE AND RECEIPT INFORMATION

The sample(s) was received, prepared, and analyzed within the method specified holding times unless otherwise noted on the Certificate of Analysis. Samples, when shipped, arrived within acceptable temperature requirements of 0° to 6° Celsius unless otherwise noted on the Report of Sample Integrity. Samples collected by BSK Analytical Laboratories were collected in accordance with the BSK Sampling and Collection Standard Operating Procedures.

QUALITY CONTROL

All analytical quality controls are within established method criteria except when noted in the Quality Control section or on the Certificate of Analysis. All positive results for EPA Methods 504.1, 502.2, and 524.2 require the analysis of a Field Reagent Blank (FRB) to confirm that the results are not a contamination error from field sampling steps. If Field Reagent Blanks were not submitted with the samples, this method requirement has not been performed. OC samples may include analytes not requested in this submission.

<u>RUN</u>	<u>ORDER</u>	<u>TEST</u>	<u>ANALYTE</u>	<u>COMMENT</u>
167518	1086164	EPA 8260B	Methyl-t-Butyl Ether	MS recovery was affected by the matrix.

SAMPLE RESULT INFORMATION

Samples are analyzed as received (wet weight basis) unless noted here. The results relate only to the items tested. Any exceptions to be considered when evaluating these results are also listed here, if applicable. Results contained in this package shall not be reproduced, except in full, without written approval of BSK Analytical Laboratories.

<u>ORDER</u>	<u>TEST</u>	<u>ANALYTE</u>	<u>COMMENT</u>
--------------	-------------	----------------	----------------



Jeff Yeazell
BSK Associates - Sacramento
3140 Gold Camp Drive Suite 160
Rancho Cordova, CA 95670

BSK Submission #: 2009020490

BSK Sample ID #: 1084227

Report Issue Date: 02/20/2009

Project ID: E0805401S

Project Desc: Unocal Castro Valley

Submission Comments:

Sample Type: Liquid

Date Sampled: 02/06/2009

Sample Description: MW-5

Time Sampled: 1205

Sample Comments:

Date Received: 02/06/2009

Organics

Analyte	Method	Result	Units	PQL	Dilution	DLR	Prep Date/Time	Analysis Date/Time
TPH as Diesel (C10-C28)	EPA 8015B	ND	µg/L	50	1	50	02/12/09	02/13/09
TPH as Gasoline (C6-C10)	EPA 8015B	ND	µg/L	50	1	50	02/13/09	02/14/09
Benzene	EPA 8021B	ND	µg/L	0.30	1	0.30	02/13/09	02/14/09
Ethylbenzene	EPA 8021B	ND	µg/L	0.30	1	0.30	02/13/09	02/14/09
Toluene	EPA 8021B	ND	µg/L	0.30	1	0.30	02/13/09	02/14/09
Total Xylenes	EPA 8021B	ND	µg/L	0.30	1	0.30	02/13/09	02/14/09
1,2-Dibromoethane	EPA 8260B	ND	µg/L	5.0	1	5.0	02/12/09	02/13/09
1,2-Dichloroethane	EPA 8260B	ND	µg/L	5.0	1	5.0	02/12/09	02/13/09
Di-isopropyl Ether	EPA 8260B	ND	µg/L	5.0	1	5.0	02/12/09	02/13/09
Ethyl t-Butyl Ether	EPA 8260B	ND	µg/L	5.0	1	5.0	02/12/09	02/13/09
Methyl-t-Butyl Ether	EPA 8260B	ND	µg/L	5.0	1	5.0	02/12/09	02/13/09
t-Amyl Methyl Ether	EPA 8260B	ND	µg/L	5.0	1	5.0	02/12/09	02/13/09
tert-Butyl Alcohol	EPA 8260B	ND	µg/L	50	1	50	02/12/09	02/13/09

Surrogate

Tetracosane	EPA 8015B	120	% Rec	-	1	N/A	02/12/09	02/13/09
Fluorobenzene	EPA 8021B	100	% Rec	-	1	N/A	02/13/09	02/14/09
Toluene-d8	EPA 8260B	100	% Rec	-	1	N/A	02/12/09	02/13/09

mg/L: Milligrams/Liter (ppm)
mg/Kg: Milligrams/Kilogram (ppm)
µg/L: Micrograms/Liter (ppb)
µg/Kg: Micrograms/Kilogram (ppb)
%Rec: Percent Recovered (surrogates)

PQL: Practical Quantitation Limit
DLR: Detection Limit for Reporting
: PQL x Dilution
ND: None Detected at DLR
pCi/L: Picocurie per Liter

H: Analyzed outside of hold time
P: Preliminary result
S: Suspect result. See Case Narrative for comments.
E: Analysis performed by External laboratory.
See External Laboratory Report attachments.
MDC: Min Detectable Concentration

Report Authentication Code:



Jeff Yeazell
BSK Associates - Sacramento
3140 Gold Camp Drive Suite 160
Rancho Cordova, CA 95670

BSK Submission #: 2009020490

BSK Sample ID #: 1084228

Report Issue Date: 02/20/2009

Project ID: E0805401S

Project Desc: Unocal Castro Valley

Submission Comments:

Sample Type: Liquid

Date Sampled: 02/06/2009

Sample Description: MW-6

Time Sampled: 1310

Sample Comments:

Date Received: 02/06/2009

Organics

Analyte	Method	Result	Units	PQL	Dilution	DLR	Prep Date/Time	Analysis Date/Time
TPH as Diesel (C10-C28)	EPA 8015B	ND	µg/L	50	1	50	02/12/09	02/13/09
TPH as Gasoline (C6-C10)	EPA 8015B	ND	µg/L	50	1	50	02/13/09	02/14/09
Benzene	EPA 8021B	ND	µg/L	0.30	1	0.30	02/13/09	02/14/09
Ethylbenzene	EPA 8021B	ND	µg/L	0.30	1	0.30	02/13/09	02/14/09
Toluene	EPA 8021B	ND	µg/L	0.30	1	0.30	02/13/09	02/14/09
Total Xylenes	EPA 8021B	ND	µg/L	0.30	1	0.30	02/13/09	02/14/09
1,2-Dibromoethane	EPA 8260B	ND	µg/L	5.0	1	5.0	02/12/09	02/13/09
1,2-Dichloroethane	EPA 8260B	ND	µg/L	5.0	1	5.0	02/12/09	02/13/09
Di-isopropyl Ether	EPA 8260B	ND	µg/L	5.0	1	5.0	02/12/09	02/13/09
Ethyl t-Butyl Ether	EPA 8260B	ND	µg/L	5.0	1	5.0	02/12/09	02/13/09
Methyl-t-Butyl Ether	EPA 8260B	200	µg/L	5.0	20	100	02/13/09	02/13/09
t-Amyl Methyl Ether	EPA 8260B	ND	µg/L	5.0	1	5.0	02/12/09	02/13/09
tert-Butyl Alcohol	EPA 8260B	ND	µg/L	50	1	50	02/12/09	02/13/09

Surrogate

Tetracosane	EPA 8015B	98	% Rec	-	1	N/A	02/12/09	02/13/09
Fluorobenzene	EPA 8021B	100	% Rec	-	1	N/A	02/13/09	02/14/09
Toluene-d8	EPA 8260B	100	% Rec	-	1	N/A	02/12/09	02/13/09

mg/L: Milligrams/Liter (ppm)
mg/Kg: Milligrams/Kilogram (ppm)
µg/L: Micrograms/Liter (ppb)
µg/Kg: Micrograms/Kilogram (ppb)
%Rec: Percent Recovered (surrogates)

PQL: Practical Quantitation Limit
DLR: Detection Limit for Reporting
: PQL x Dilution
ND: None Detected at DLR
pCi/L: Picocurie per Liter

H: Analyzed outside of hold time
P: Preliminary result
S: Suspect result. See Case Narrative for comments.
E: Analysis performed by External laboratory.
See External Laboratory Report attachments.
MDC: Min Detectable Concentration

Report Authentication Code:



Jeff Yeazell
BSK Associates - Sacramento
3140 Gold Camp Drive Suite 160
Rancho Cordova, CA 95670

BSK Submission #: 2009020490

BSK Sample ID #: 1084229

Report Issue Date: 02/20/2009

Project ID: E0805401S

Project Desc: Unocal Castro Valley

Submission Comments:

Sample Type: Liquid

Date Sampled: 02/06/2009

Sample Description: MW-7

Time Sampled: 1410

Sample Comments:

Date Received: 02/06/2009

Organics

Analyte	Method	Result	Units	PQL	Dilution	DLR	Prep Date/Time	Analysis Date/Time
TPH as Diesel (C10-C28)	EPA 8015B	ND	µg/L	50	1	50	02/12/09	02/13/09
TPH as Gasoline (C6-C10)	EPA 8015B	320	µg/L	50	1	50	02/13/09	02/14/09
Benzene	EPA 8021B	ND	µg/L	0.30	1	0.30	02/13/09	02/14/09
Ethylbenzene	EPA 8021B	ND	µg/L	0.30	1	0.30	02/13/09	02/14/09
Toluene	EPA 8021B	ND	µg/L	0.30	1	0.30	02/13/09	02/14/09
Total Xylenes	EPA 8021B	ND	µg/L	0.30	1	0.30	02/13/09	02/14/09
1,2-Dibromoethane	EPA 8260B	ND	µg/L	5.0	1	5.0	02/12/09	02/13/09
1,2-Dichloroethane	EPA 8260B	ND	µg/L	5.0	1	5.0	02/12/09	02/13/09
Di-isopropyl Ether	EPA 8260B	ND	µg/L	5.0	1	5.0	02/12/09	02/13/09
Ethyl t-Butyl Ether	EPA 8260B	ND	µg/L	5.0	1	5.0	02/12/09	02/13/09
Methyl-t-Butyl Ether	EPA 8260B	ND	µg/L	5.0	1	5.0	02/12/09	02/13/09
t-Amyl Methyl Ether	EPA 8260B	ND	µg/L	5.0	1	5.0	02/12/09	02/13/09
tert-Butyl Alcohol	EPA 8260B	ND	µg/L	50	1	50	02/12/09	02/13/09

Surrogate

Tetracosane	EPA 8015B	100	% Rec	-	1	N/A	02/12/09	02/13/09
Fluorobenzene	EPA 8021B	99	% Rec	-	1	N/A	02/13/09	02/14/09
Toluene-d8	EPA 8260B	100	% Rec	-	1	N/A	02/12/09	02/13/09

mg/L: Milligrams/Liter (ppm)
mg/Kg: Milligrams/Kilogram (ppm)
µg/L: Micrograms/Liter (ppb)
µg/Kg: Micrograms/Kilogram (ppb)
%Rec: Percent Recovered (surrogates)

PQL: Practical Quantitation Limit
DLR: Detection Limit for Reporting
: PQL x Dilution
ND: None Detected at DLR
pCi/L: Picocurie per Liter

H: Analyzed outside of hold time
P: Preliminary result
S: Suspect result. See Case Narrative for comments.
E: Analysis performed by External laboratory.
See External Laboratory Report attachments.
MDC: Min Detectable Concentration

Report Authentication Code:



Jeff Yeazell
BSK Associates - Sacramento
3140 Gold Camp Drive Suite 160
Rancho Cordova, CA 95670

BSK Submission #: 2009020490

BSK Sample ID #: 1084230

Report Issue Date: 02/20/2009

Project ID: E0805401S

Project Desc: Unocal Castro Valley

Submission Comments:

Sample Type: Liquid

Date Sampled: 02/06/2009

Sample Description: MW-101

Time Sampled: 1625

Sample Comments:

Date Received: 02/06/2009

Organics

Analyte	Method	Result	Units	PQL	Dilution	DLR	Prep Date/Time	Analysis Date/Time
TPH as Diesel (C10-C28)	EPA 8015B	3600	µg/L	50	1	50	02/12/09	02/13/09
TPH as Gasoline (C6-C10)	EPA 8015B	ND	µg/L	50	1	50	02/13/09	02/14/09
Benzene	EPA 8021B	ND	µg/L	0.30	1	0.30	02/13/09	02/14/09
Ethylbenzene	EPA 8021B	ND	µg/L	0.30	1	0.30	02/13/09	02/14/09
Toluene	EPA 8021B	ND	µg/L	0.30	1	0.30	02/13/09	02/14/09
Total Xylenes	EPA 8021B	ND	µg/L	0.30	1	0.30	02/13/09	02/14/09
1,2-Dibromoethane	EPA 8260B	ND	µg/L	5.0	1	5.0	02/12/09	02/13/09
1,2-Dichloroethane	EPA 8260B	ND	µg/L	5.0	1	5.0	02/12/09	02/13/09
Di-isopropyl Ether	EPA 8260B	ND	µg/L	5.0	1	5.0	02/12/09	02/13/09
Ethyl t-Butyl Ether	EPA 8260B	ND	µg/L	5.0	1	5.0	02/12/09	02/13/09
Methyl-t-Butyl Ether	EPA 8260B	630	µg/L	5.0	50	250	02/13/09	02/13/09
t-Amyl Methyl Ether	EPA 8260B	ND	µg/L	5.0	1	5.0	02/12/09	02/13/09
tert-Butyl Alcohol	EPA 8260B	ND	µg/L	50	1	50	02/12/09	02/13/09

Surrogate

Tetracosane	EPA 8015B	110	% Rec	-	1	N/A	02/12/09	02/13/09
Fluorobenzene	EPA 8021B	100	% Rec	-	1	N/A	02/13/09	02/14/09
Toluene-d8	EPA 8260B	100	% Rec	-	1	N/A	02/12/09	02/13/09

LUFT Comments

TPH as Diesel (C10-C28) Higher boiling point hydrocarbons decreased relative to standard

mg/L: Milligrams/Liter (ppm)
mg/Kg: Milligrams/Kilogram (ppm)
µg/L: Micrograms/Liter (ppb)
µg/Kg: Micrograms/Kilogram (ppb)
%Rec: Percent Recovered (surrogates)

PQL: Practical Quantitation Limit
DLR: Detection Limit for Reporting
: PQL x Dilution
ND: None Detected at DLR
pCi/L: Picocurie per Liter

H: Analyzed outside of hold time
P: Preliminary result
S: Suspect result. See Case Narrative for comments.
E: Analysis performed by External laboratory.
See External Laboratory Report attachments.
MDC: Min Detectable Concentration

Report Authentication Code:



QC Summary Report

02/20/2009



BSK Submission : 2009020490
Client : BSK Associates - Sacramento
Date Submitted : 02/06/2009
Project ID : E0805401S

NELAP Certificate #04227CA
ELAP Certificate #1180

Project Desc : Unocal Castro Valley

BSK StarLims Run #: 167517



Analyst Initials: AMYN

Method Number: 8260OX

Analyte	QC Type	Matrix Spike ID	Result	Units	% Rec or RPD	Spike RPD	Spk Conc	Matrix Conc	UCL	LCL	Date	
1,2-Dibromoethane	LCS	N/A	12	µg/L	92		12.5	ND	130	80	02/12/09	Acceptable
1,2-Dichloroethane	LCS	N/A	11	µg/L	88		12.5	ND	130	75	02/12/09	Acceptable
Di-isopropyl Ether	LCS	N/A	11	µg/L	90		12.5	ND	130	80	02/12/09	Acceptable
Ethyl t-Butyl Ether	LCS	N/A	11	µg/L	88		12.5	ND	130	70	02/12/09	Acceptable
Methyl-t-Butyl Ether	LCS	N/A	11	µg/L	87		12.5	ND	130	80	02/12/09	Acceptable
t-Amyl Methyl Ether	LCS	N/A	11	µg/L	89		12.5	ND	140	60	02/12/09	Acceptable
tert-Butyl Alcohol	LCS	N/A	110	µg/L	91		125.0	ND	140	60	02/12/09	Acceptable
1,2-Dibromoethane	LCSD	N/A	13	µg/L	102	10	12.5	ND	130	80	02/12/09	Acceptable
1,2-Dichloroethane	LCSD	N/A	13	µg/L	106	19	12.5	ND	130	75	02/12/09	Acceptable
Di-isopropyl Ether	LCSD	N/A	13	µg/L	105	14	12.5	ND	130	80	02/12/09	Acceptable
Ethyl t-Butyl Ether	LCSD	N/A	14	µg/L	111	22	12.5	ND	130	70	02/12/09	Acceptable
Methyl-t-Butyl Ether	LCSD	N/A	14	µg/L	108	21	12.5	ND	130	80	02/12/09	Acceptable
t-Amyl Methyl Ether	LCSD	N/A	14	µg/L	110	21	12.5	ND	140	60	02/12/09	Acceptable
tert-Butyl Alcohol	LCSD	N/A	140	µg/L	115	23	125.00	ND	140	60	02/12/09	Acceptable
1,2-Dibromoethane	RBLK	N/A	ND	µg/L	< 5.0				5.0	N/A	02/12/09	Acceptable
1,2-Dichloroethane	RBLK	N/A	ND	µg/L	< 5.0				5.0	N/A	02/12/09	Acceptable
Di-isopropyl Ether	RBLK	N/A	ND	µg/L	< 5.0				5.0	N/A	02/12/09	Acceptable
Ethyl t-Butyl Ether	RBLK	N/A	ND	µg/L	< 5.0				5.0	N/A	02/12/09	Acceptable
Methyl-t-Butyl Ether	RBLK	N/A	ND	µg/L	< 5.0				5.0	N/A	02/12/09	Acceptable
t-Amyl Methyl Ether	RBLK	N/A	ND	µg/L	< 5.0				5.0	N/A	02/12/09	Acceptable
tert-Butyl Alcohol	RBLK	N/A	ND	µg/L	< 5.0				5.0	N/A	02/12/09	Acceptable

Surrogate Results

Analyte	QC Type	Surr. Result	UCL	LCL	Date	
Toluene-d8	LCS	N/A 100 % Rec	100	120	80	02/12/09 Acceptable
Toluene-d8	LCSD	N/A 100 % Rec	100	120	80	02/12/09 Acceptable
Toluene-d8	RBLK	N/A 100 % Rec	N/A	N/A	02/12/09	Acceptable

StarLims Run 167517 includes the following BSK Sample ID# :

1083530 1083970 1083971 1083972 1083973 1083974 1083975 1083976 1084227 1086158 1086159 1086160

BSK StarLims Run #: 167518



Analyst Initials: AMYN

Method Number: 8260OX

Analyte Results

Analyte	QC Type	Matrix Spike ID	Result	Units	% Rec or RPD	Spike RPD	Spk Conc	Matrix Conc	UCL	LCL	Date
---------	---------	-----------------	--------	-------	--------------	-----------	----------	-------------	-----	-----	------

%Rec: Percent Recovered
RPD: Relative Percent Difference
UCL: Upper Control Limit
LCL: Lower Control Limit
LCS: Laboratory Control Sample
LCSD: Laboratory Control Sample Duplicate
LDUP: Laboratory Sample Duplicate

Parent Sample: Sample used as background matrix for MS/MSD
OOS-High: QC Result Above UCL
OOS-Low: QC Result Below LCL
MS: Matrix Spike
MSD: Matrix Spike Duplicate
RBLK: Reagent (Method) Blank

Surrogate results for QC standards are not evaluated for acceptability (due to definition of a surrogate standard)

QC Summary Report

02/20/2009



NELAP Certificate #04227CA
ELAP Certificate #1180

BSK Submission : 2009020490
Client : BSK Associates - Sacramento
Date Submitted : 02/06/2009
Project ID : E0805401S

Project Desc : Unocal Castro Valley

BSK StarLims Run #: 167518



Analyst Initials: AMYN

Method Number: 8260OX

Analyte	QC Type	Matrix Spike ID	Result	Units	% Rec or RPD	Spike RPD	Spk Conc	Matrix Conc	UCL	LCL	Date	
1,2-Dibromoethane	LCS	N/A	12	µg/L	98		12.5	ND	130	80	02/13/09	Acceptable
1,2-Dichloroethane	LCS	N/A	12	µg/L	99		12.5	ND	130	75	02/13/09	Acceptable
Di-isopropyl Ether	LCS	N/A	13	µg/L	100		12.5	ND	130	80	02/13/09	Acceptable
Ethyl t-Butyl Ether	LCS	N/A	13	µg/L	102		12.5	ND	130	70	02/13/09	Acceptable
Methyl-t-Butyl Ether	LCS	N/A	13	µg/L	103		12.5	ND	130	80	02/13/09	Acceptable
t-Amyl Methyl Ether	LCS	N/A	12	µg/L	100		12.50	ND	140	60	02/13/09	Acceptable
tert-Butyl Alcohol	LCS	N/A	140	µg/L	109		125.0	ND	140	60	02/13/09	Acceptable
1,2-Dibromoethane	LCSD	N/A	13	µg/L	101	3	12.5	ND	130	80	02/13/09	Acceptable
1,2-Dichloroethane	LCSD	N/A	12	µg/L	98	0.48	12.5	ND	130	75	02/13/09	Acceptable
Di-isopropyl Ether	LCSD	N/A	12	µg/L	98	2.6	12.50	ND	130	80	02/13/09	Acceptable
Ethyl t-Butyl Ether	LCSD	N/A	12	µg/L	99	3	12.5	ND	130	70	02/13/09	Acceptable
Methyl-t-Butyl Ether	LCSD	N/A	12	µg/L	98	5	12.5	ND	130	80	02/13/09	Acceptable
t-Amyl Methyl Ether	LCSD	N/A	12	µg/L	99	0.24	12.5	ND	140	60	02/13/09	Acceptable
tert-Butyl Alcohol	LCSD	N/A	130	µg/L	101	7	125.0	ND	140	60	02/13/09	Acceptable
1,2-Dibromoethane	MS	1085805	12	µg/L	94		12.5	ND	130	80	02/13/09	Acceptable
1,2-Dichloroethane	MS	1085805	11	µg/L	85		12.5	ND	130	75	02/13/09	Acceptable
Di-isopropyl Ether	MS	1085805	11	µg/L	88		12.5	ND	130	70	02/13/09	Acceptable
Ethyl t-Butyl Ether	MS	1085805	11	µg/L	86		12.5	ND	130	70	02/13/09	Acceptable
Methyl-t-Butyl Ether	MS	1085805	65	µg/L	16		12.5	62	145	70	02/13/09	OOS-Low
t-Amyl Methyl Ether	MS	1085805	11	µg/L	87		12.5	ND	125	70	02/13/09	Acceptable
tert-Butyl Alcohol	MS	1085805	100	µg/L	82		125.0	ND	140	70	02/13/09	Acceptable
1,2-Dibromoethane	MSD	1085805	12	µg/L	100	5.3	12.5	ND	130	80	02/13/09	Acceptable
1,2-Dichloroethane	MSD	1085805	12	µg/L	97	13	12.5	ND	130	75	02/13/09	Acceptable
Di-isopropyl Ether	MSD	1085805	13	µg/L	104	16	12.5	ND	130	70	02/13/09	Acceptable
Ethyl t-Butyl Ether	MSD	1085805	13	µg/L	103	18	12.5	ND	130	70	02/13/09	Acceptable
Methyl-t-Butyl Ether	MSD	1085805	76	µg/L	109	16	12.5	62	145	70	02/13/09	Acceptable
t-Amyl Methyl Ether	MSD	1085805	13	µg/L	102	15	12.5	ND	125	70	02/13/09	Acceptable
tert-Butyl Alcohol	MSD	1085805	130	µg/L	106	24	125.0	ND	140	70	02/13/09	Acceptable
1,2-Dibromoethane	RBLK	N/A	ND	µg/L	< 5.0				5.0	N/A	02/13/09	Acceptable
1,2-Dichloroethane	RBLK	N/A	ND	µg/L	< 5.0				5.0	N/A	02/13/09	Acceptable
Di-isopropyl Ether	RBLK	N/A	ND	µg/L	< 5.0				5.0	N/A	02/13/09	Acceptable
Ethyl t-Butyl Ether	RBLK	N/A	ND	µg/L	< 5.0				5.0	N/A	02/13/09	Acceptable
Methyl-t-Butyl Ether	RBLK	N/A	ND	µg/L	< 5.0				5.0	N/A	02/13/09	Acceptable
t-Amyl Methyl Ether	RBLK	N/A	ND	µg/L	< 5.0				5.0	N/A	02/13/09	Acceptable
tert-Butyl Alcohol	RBLK	N/A	ND	µg/L	< 5.0				5.0	N/A	02/13/09	Acceptable

%Rec: Percent Recovered
RPD: Relative Percent Difference
UCL: Upper Control Limit
LCL: Lower Control Limit
LCS: Laboratory Control Sample
LCSD: Laboratory Control Sample Duplicate
LDUP: Laboratory Sample Duplicate

Parent Sample: Sample used as background matrix for MS/MSD
OOS-High: QC Result Above UCL
OOS-Low: QC Result Below LCL
MS: Matrix Spike
MSD: Matrix Spike Duplicate
RBLK: Reagent (Method) Blank

Surrogate results for QC standards are not evaluated for acceptability (due to definition of a surrogate standard)

QC Summary Report

02/20/2009



NELAP Certificate #04227CA
ELAP Certificate #1180

BSK Submission : 2009020490
Client : BSK Associates - Sacramento
Date Submitted : 02/06/2009
Project ID : E0805401S

Project Desc : Unocal Castro Valley

BSK StarLims Run #: 167518



Analyst Initials: AMYN

Method Number: 8260OX

Run	Test	Analyte	Comment
167518	8260OX	MTBE	MS recovery was affected by the matrix.

Surrogate Results

Analyte	QC Type	Surr. Result	UCL	LCL	Date
Toluene-d8	LCS N/A	100 % Rec	100	120 80	02/13/09 Acceptable
Toluene-d8	LCSD N/A	100 % Rec	100	120 80	02/13/09 Acceptable
Toluene-d8	MS 1085805	100 % Rec	100	130 80	02/13/09 Acceptable
Toluene-d8	MSD 1085805	100 % Rec	100	130 80	02/13/09 Acceptable
Toluene-d8	RBLK N/A	100 % Rec	N/A	N/A	02/13/09 Acceptable

StarLims Run 167518 includes the following BSK Sample ID# :

1084228 1084229 1084230 1085804 1085805 1086161 1086162 1086163 1086164 1086165

BSK StarLims Run #: 167537



Analyst Initials: PAOY

Method Number: TPHD_LL

Analyte Results

Analyte	QC Type	Matrix Spike ID	Result	Units	% Rec or RPD	Spike RPD	Spk Conc	Matrix Conc	UCL	LCL	Date
TPH as Diesel (C10-C28)	LCS	N/A	3100	µg/L	123		2500	ND	130	70	02/13/09 Acceptable
TPH as Diesel (C10-C28)	LCSD	N/A	3100	µg/L	124	0.46	2500	ND	130	70	02/13/09 Acceptable
TPH as Diesel (C10-C28)	MS	1083937	3100	µg/L	121		2500	100	130	70	02/13/09 Acceptable
TPH as Diesel (C10-C28)	RBLK	N/A	ND	µg/L	< 50				50	N/A	02/13/09 Acceptable

Surrogate Results

Analyte	QC Type	Surr. Result	UCL	LCL	Date
Tetracosane	LCS N/A	160 % Rec	150	189 45	02/13/09 Acceptable
Tetracosane	LCSD N/A	240 % Rec	150	189 45	02/13/09 OOS-High
Tetracosane	MS 1083937	91 % Rec	69	189 45	02/13/09 Acceptable
Tetracosane	RBLK N/A	150 % Rec	N/A	N/A	02/13/09 Acceptable

StarLims Run 167537 includes the following BSK Sample ID# :

1083937 1084200 1084227 1084228 1084229 1084230 1085804 1085805 1086278 1086279 1086280 1086281

BSK StarLims Run #: 167583



Analyst Initials: PAOY

Method Number: BTEX_LL

Analyte Results

Analyte	QC Type	Matrix Spike ID	Result	Units	% Rec or RPD	Spike RPD	Spk Conc	Matrix Conc	UCL	LCL	Date

%Rec: Percent Recovered
RPD: Relative Percent Difference
UCL: Upper Control Limit
LCL: Lower Control Limit
LCS: Laboratory Control Sample
LCSD: Laboratory Control Sample Duplicate
LDUP: Laboratory Sample Duplicate

Parent Sample: Sample used as background matrix for MS/MSD
OOS-High: QC Result Above UCL
OOS-Low: QC Result Below LCL
MS: Matrix Spike
MSD: Matrix Spike Duplicate
RBLK: Reagent (Method) Blank

QC Summary Report

02/20/2009



NELAP Certificate #04227CA
ELAP Certificate #1180

BSK Submission : 2009020490
Client : BSK Associates - Sacramento
Date Submitted : 02/06/2009
Project ID : E0805401S

Project Desc : Unocal Castro Valley

BSK StarLims Run #: 167583



Analyst Initials: PAOY

Method Number: BTEX_LL

Analyte Results	QC Type	Matrix Spike ID	Result	Units	% Rec or RPD	Spike RPD	Spk Conc	Matrix Conc	UCL	LCL	Date	
Benzene	LCS	N/A	20	µg/L	98		20	ND	130	70	02/13/09	Acceptable
Ethylbenzene	LCS	N/A	20	µg/L	100		20	ND	130	70	02/13/09	Acceptable
Toluene	LCS	N/A	19	µg/L	96		20	ND	130	70	02/13/09	Acceptable
Total Xylenes	LCS	N/A	59	µg/L	98		60	ND	130	70	02/13/09	Acceptable
TPH as Gasoline (C6-C10)	LCS	N/A	120	µg/L	98		120	ND	130	70	02/13/09	Acceptable
Benzene	LCSD	N/A	21	µg/L	103	4.8	20	ND	130	70	02/14/09	Acceptable
Ethylbenzene	LCSD	N/A	21	µg/L	106	5.4	20	ND	130	70	02/14/09	Acceptable
Toluene	LCSD	N/A	20	µg/L	101	4.6	20	ND	130	70	02/14/09	Acceptable
Total Xylenes	LCSD	N/A	63	µg/L	104	6.2	60	ND	130	70	02/14/09	Acceptable
TPH as Gasoline (C6-C10)	LCSD	N/A	120	µg/L	103	5	120	ND	130	70	02/14/09	Acceptable
Benzene	MS	1083976	11	µg/L	110		10	ND	130	70	02/14/09	Acceptable
Ethylbenzene	MS	1083976	11	µg/L	111		10	ND	130	70	02/14/09	Acceptable
Toluene	MS	1083976	11	µg/L	106		10	ND	130	70	02/14/09	Acceptable
Total Xylenes	MS	1083976	33	µg/L	110		30	ND	130	70	02/14/09	Acceptable
TPH as Gasoline (C6-C10)	MS	1083976	65	µg/L	108		60	ND	130	70	02/14/09	Acceptable
Benzene	RBLK	N/A	ND	µg/L	< 0.30				0.30	N/A	02/13/09	Acceptable
Ethylbenzene	RBLK	N/A	ND	µg/L	< 0.30				0.30	N/A	02/13/09	Acceptable
Toluene	RBLK	N/A	ND	µg/L	< 0.30				0.30	N/A	02/13/09	Acceptable
Total Xylenes	RBLK	N/A	ND	µg/L	< 0.30				0.30	N/A	02/13/09	Acceptable
TPH as Gasoline (C6-C10)	RBLK	N/A	ND	µg/L	< 50				50	N/A	02/13/09	Acceptable

Surrogate Results

Analyte	QC Type	Surr. Result	UCL	LCL	Date	
Fluorobenzene	LCS	N/A 97 % Rec	100	130	70	02/13/09 Acceptable
Fluorobenzene	LCSD	N/A 100 % Rec	100	130	70	02/14/09 Acceptable
Fluorobenzene	MS	1083976 110 % Rec	100	130	70	02/14/09 Acceptable
Fluorobenzene	RBLK	N/A 100 % Rec	N/A	N/A	02/13/09	Acceptable

StarLims Run 167583 includes the following BSK Sample ID#:

1083937 1083976 1084200 1084227 1084228 1084229 1084230 1085804 1085805 1086581 1086582 1086583 1086584

Approved by: Maia C. Manuel

%Rec: Percent Recovered
RPD: Relative Percent Difference
UCL: Upper Control Limit
LCL: Lower Control Limit
LCS: Laboratory Control Sample
LCSD: Laboratory Control Sample Duplicate
LDUP: Laboratory Sample Duplicate

Parent Sample: Sample used as background matrix for MS/MSD
OOS-High: QC Result Above UCL
OOS-Low: QC Result Below LCL
MS: Matrix Spike
MSD: Matrix Spike Duplicate
RBLK: Reagent (Method) Blank

Surrogate results for QC standards are not evaluated for acceptability (due to definition of a surrogate standard)

Sample Integrity

Pg. 1 of 2

2009020490

02/06/2009

BSK S

TAT: Standard

26138

Date Received 2/6/09



Section 1- Sampled Same Day
 Sample Transport: Walk In SJVC BSK-Courier Transported In: Ice Chest Box Hand
 Has chilling process begun? Y N Samples Received: Chilled to Touch / Ambient / On Ice

Section 2- Sampled Previously
 Sample Transport: CAO UPS SJVC Walk-In BSK-Courier GSO Fed Exp. Other: _____
 No. Coolers/Ice Chests: _____ Temperature(s): _____
 Was Temperature In Range: Y N Received On Ice: Wet Blue
 Describe type of packing materials: Bubble Wrap Foam Packing Peanuts Paper Other: _____
 Were ice chest custody seals present? Y N Intact: Y N

Section 3- COC Info.	Completed		Info From Container		Completed		Info From Container
	Yes	No			Yes	No	
Was COC Received	✓			Analysis Requested	✓		
Date Sampled	✓			Any hold times less than 72hr		✓	
Time Sampled	✓			Client Name	✓		
Sample ID	✓			Address	✓		
Special Storage/Handling Ins.		✓		Telephone #	✓		

Section 4- Bottles / Analysis	Yes	No	N/A	Comment
Did all bottles arrive unbroken and intact?:	✓			
Were bottle custody seals present?			✓	
Were bottle custody seals intact?			✓	
Did all bottle labels agree with COC?:	✓			
Were correct containers used for the tests requested?:	✓			
Were correct preservations used for the tests requested?:	✓			
Was a sufficient amount of sample sent for tests indicated?:	✓			
Were bubbles present in VOA Vials?: (Volatile Methods Only)			✓	
Were Ascorbic Acid Bottles received with the VOAs			✓	

Section 5- Comments / Discrepancies
 Sample(s) Split/Preserve: Yes No Container: _____ Preservation: _____ Init.: _____
 Was Client Service Rep. notified of discrepancies: Yes No N/A CSR: _____ Notified By: _____
 Explanations / Comments

 Report Comment Entered:

Labeled by: [Signature]

Labels checked by: [Signature]

Sample Integrity

Pg 2 of 2

2009020490

02/06/2009

BSK S

TAT: Standard

SR-FL-0002-02

BSK Bottles Yes No

26138

8oz (A) 16oz (B) 32oz (C) Amber Glass (AG)



Container(s) Received	1-4								
Bacti Na ₂ S ₂ O ₃									
None (p) ^{White Cap}									
None (p) ^{Blue Cap}									
HNO ₃ (p) ^{Red Cap}									
H ₂ SO ₄ (p) ^{Yellow Cap}									
NaOH (p) ^{Green Cap}									
Other:									
Dissolved Oxygen 300ml (g)									
250ml (AG) None									
250ml (AG) H ₂ SO ₄ COD ^{Yellow Label}									
250ml (AG) Na ₂ S ₂ O ₃ 515,547 ^{Blue Label}									
250ml (AG) Na ₂ S ₂ O ₃ + MCAA 531.1 ^{Orange Label}									
250ml (AG) NH ₄ Cl 552 ^{Purple Label}									
250ml (AG) EDA DBPs ^{Brown Label}									
250ml (AG) Other:									
500ml (AG) None									
500ml (AG) H ₂ SO ₄ TPH-Diesel ^{Yellow Label}	1								
1 Liter (AG) None									
1 Liter (AG) H ₂ SO ₄ O&G ^{Yellow Label}									
1 Liter (AG) Na ₂ S ₂ O ₃ 548 / 525 / 521 ^{Blue Label}									
1 Liter (P) Na ₂ S ₂ O ₃ + H ₂ SO ₄ 549									
1 Liter (AG) NaOH+ZnAc Sulfide									
1 Liter (AG) Ascorbic/EDTA/Pot Citrate 527 ^{Grey Label}									
1 Liter (AG) CuSO ₄ /Trizma 529 ^{Turquoise Label}									
1 Liter (AG) Na ₂ SO ₃ / HCL 525 UCMR ^{Neon Green Label}									
1 Liter (AG) Ammonium Chloride 535 ^{Purple Label}									
40ml VOA Vial Clear - HCL	6								
40ml VOA Vial Amber - Na ₂ S ₂ O ₃									
40ml VOA Vial Clear - None									
40ml VOA Vial Clear - Na ₂ S ₂ O ₃ 504, 505									
40ml VOA Vial Clear - H ₃ PO ₄									
Other:									
Asbestos 32oz Plastic/Foil									
Radiological GA / GB (1/2 Gal Plastic)									
Radiological 226 / 228 (32 oz plastic N-BSK)									
Radon 200ml Clear (g)									
Low Level Hg/Metals Double Baggie									
THM-FP 4-40ml VOA None									
250 Clear Glass Jar									
500 Clear Glass Jar									
1 Liter Clear Glass Jar									
Plastic Bag									
Soil Tube Brass / Steel / Plastic									
Tedlar Bags									

[Large handwritten scribble or signature across the table]

[Handwritten signature]
2/6/09

BSK ANALYTICAL LABORATORIES

1414 Stanislaus, Fresno CA 93706
 (559) 497-2888, (800) 877-8310, FAX (559) 485-6935

BSK Submission: 26138
 COC Number: _____
 Global ID Number: T0600101370

2009020490 02/06/2009
 BSK S TAT: Standard
 26138



Facility/Project Name			Report Attention			Method Preserved					BTEX/TPH-G (8020/8015M)	TPH-Diesel (8015M)	Fuel Oxygenates (8260B)	Lead Scavengers (8260E)	Rush Priority (1-Day, 2-Day, 5)
Unocal Castro Valley			Jeff Yeazell			Method Preserved									
Address			BSK Job No.: E0805401S			HCl	HNO3	H2SO4	NONE	OTHER (List)					
City, State, Zip			Copy to:												
Phone			FAX:												
Lab Use Only		Sampling Info		Sampled by: DAVID J. CUELLAR											
S#	T#	#C	Date	Time	Field Point Name										
1		7	2/6/09	1205	MW-5	✓		✓			✓	✓	✓	✓	
2				1310	MW-6	✓		✓			✓	✓	✓	✓	1084227
3				1410	MW-7	✓		✓			✓	✓	✓	✓	228
4				1625	MW-101	✓		✓			✓	✓	✓	✓	229
															230

QC Report Type: Level 2 3 4

Formal COC Required:

Electronic Data Format Required:

Email EDF To: jyeazell@bskinc.com

Low Level Fuel Oxygenates Detection Limits Req:

Received / Relinquished by:	Signature	Print Name	Company	Date/Time
Received / Relinquished by:	<i>[Signature]</i>	DAVID J. CUELLAR	BSK	2/6/09 1720
Received / Relinquished by:				
Received / Relinquished by:				
Received / Relinquished by:	<i>[Signature]</i>	<i>[Signature]</i>	BSK	2/6/09 17:20

Jeff Yeazell
BSK Associates - Sacramento
3140 Gold Camp Drive Suite 160
Rancho Cordova, CA 95670

02/20/2009

Dear Jeff Yeazell,

Thank you for selecting BSK Analytical Laboratories for your analytical testing needs. We have prepared this report in response to your request for analytical services. Please find enclosed the following sections for your complete laboratory report, each uniquely paginated:

CASE NARRATIVE: An overview of the work performed.

CERTIFICATE OF ANALYSIS: Analytical results.

QUALITY CONTROL (QC) SUMMARY: QC supporting the results presented herein.

REPORT OF SAMPLE INTEGRITY

CHAIN OF CUSTODY FORM

Certification: BSK Analytical Laboratories certifies that the test results contained in this report meet all requirements of the NELAC Standards for applicable certified drinking water chemistry analyses under CA NELAP Certificate #04227CA, CA-ELAP Certificate #1180, and Nevada Certificate #CA79. For all other matrices and bacteriological analyses, this data package is in compliance with ELAP Standards for applicable certified analyses under CA-ELAP Certificate #1180. Any exceptions to applicable standards have been noted in the case narrative. Please note that certifications are applicable only to tests and/or analytes specified on each. Certification information may be obtained by contacting the laboratory or visiting our website at www.bsklabs.com. The results in this report pertain only to the samples tested in the laboratory. This report shall not be reproduced, except in full, without written permission from BSK Analytical Laboratories.

If additional clarification of any information is required, please contact your Client Services Representative, Dan Larkin, at (800) 877-8310 or (559) 497-2888.

BSK ANALYTICAL LABORATORIES

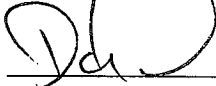

Dan Larkin

Client Services Representative



Quality Control Reviewer



SAMPLE AND RECEIPT INFORMATION

The sample(s) was received, prepared, and analyzed within the method specified holding times unless otherwise noted on the Certificate of Analysis. Samples, when shipped, arrived within acceptable temperature requirements of 0° to 6° Celsius unless otherwise noted on the Report of Sample Integrity. Samples collected by BSK Analytical Laboratories were collected in accordance with the BSK Sampling and Collection Standard Operating Procedures.

QUALITY CONTROL

All analytical quality controls are within established method criteria except when noted in the Quality Control section or on the Certificate of Analysis. All positive results for EPA Methods 504.1, 502.2, and 524.2 require the analysis of a Field Reagent Blank (FRB) to confirm that the results are not a contamination error from field sampling steps. If Field Reagent Blanks were not submitted with the samples, this method requirement has not been performed. OC samples may include analytes not requested in this submission.

<u>RUN</u>	<u>ORDER</u>	<u>TEST</u>	<u>ANALYTE</u>	<u>COMMENT</u>
167518	1086164	EPA 8260B	Methyl-t-Butyl Ether	MS recovery was affected by the matrix.

SAMPLE RESULT INFORMATION

Samples are analyzed as received (wet weight basis) unless noted here. The results relate only to the items tested. Any exceptions to be considered when evaluating these results are also listed here, if applicable. Results contained in this package shall not be reproduced, except in full, without written approval of BSK Analytical Laboratories.

<u>ORDER</u>	<u>TEST</u>	<u>ANALYTE</u>	<u>COMMENT</u>
--------------	-------------	----------------	----------------



Jeff Yeazell
BSK Associates - Sacramento
3140 Gold Camp Drive Suite 160
Rancho Cordova, CA 95670

BSK Submission #: 2009020847

BSK Sample ID #: 1085804

Report Issue Date: 02/20/2009

Project ID: E0805401S

Project Desc: Unocal Castro Valley

Submission Comments:

Sample Type: Liquid

Date Sampled: 02/11/2009

Sample Description: MW-3

Time Sampled: 1120

Sample Comments:

Date Received: 02/11/2009

Organics

Analyte	Method	Result	Units	PQL	Dilution	DLR	Prep Date/Time	Analysis Date/Time
TPH as Diesel (C10-C28)	EPA 8015B	ND	µg/L	50	1	50	02/12/09	02/13/09
TPH as Gasoline (C6-C10)	EPA 8015B	ND	µg/L	50	1	50	02/13/09	02/14/09
Benzene	EPA 8021B	ND	µg/L	0.30	1	0.30	02/13/09	02/14/09
Ethylbenzene	EPA 8021B	ND	µg/L	0.30	1	0.30	02/13/09	02/14/09
Toluene	EPA 8021B	ND	µg/L	0.30	1	0.30	02/13/09	02/14/09
Total Xylenes	EPA 8021B	ND	µg/L	0.30	1	0.30	02/13/09	02/14/09
1,2-Dibromoethane	EPA 8260B	ND	µg/L	5.0	1	5.0	02/12/09	02/13/09
1,2-Dichloroethane	EPA 8260B	ND	µg/L	5.0	1	5.0	02/12/09	02/13/09
Di-isopropyl Ether	EPA 8260B	ND	µg/L	5.0	1	5.0	02/12/09	02/13/09
Ethyl t-Butyl Ether	EPA 8260B	ND	µg/L	5.0	1	5.0	02/12/09	02/13/09
Methyl-t-Butyl Ether	EPA 8260B	12	µg/L	5.0	1	5.0	02/12/09	02/13/09
t-Amyl Methyl Ether	EPA 8260B	ND	µg/L	5.0	1	5.0	02/12/09	02/13/09
tert-Butyl Alcohol	EPA 8260B	ND	µg/L	50	1	50	02/12/09	02/13/09

Surrogate

Tetracosane	EPA 8015B	110	% Rec	-	1	N/A	02/12/09	02/13/09
Fluorobenzene	EPA 8021B	100	% Rec	-	1	N/A	02/13/09	02/14/09
Toluene-d8	EPA 8260B	99	% Rec	-	1	N/A	02/12/09	02/13/09

mg/L: Milligrams/Liter (ppm)
mg/Kg: Milligrams/Kilogram (ppm)
µg/L: Micrograms/Liter (ppb)
µg/Kg: Micrograms/Kilogram (ppb)
%Rec: Percent Recovered (surrogates)

PQL: Practical Quantitation Limit
DLR: Detection Limit for Reporting
: PQL x Dilution
ND: None Detected at DLR
pCi/L: Picocurie per Liter

H: Analyzed outside of hold time
P: Preliminary result
S: Suspect result. See Case Narrative for comments.
E: Analysis performed by External laboratory.
See External Laboratory Report attachments.
MDC: Min Detectable Concentration

Report Authentication Code:



Jeff Yeazell
BSK Associates - Sacramento
3140 Gold Camp Drive Suite 160
Rancho Cordova, CA 95670

BSK Submission #: 2009020847

BSK Sample ID #: 1085805

Report Issue Date: 02/20/2009

Project ID: E0805401S

Project Desc: Unocal Castro Valley

Submission Comments:

Sample Type: Liquid

Date Sampled: 02/11/2009

Sample Description: MW-2

Time Sampled: 1220

Sample Comments:

Date Received: 02/11/2009

Organics

Analyte	Method	Result	Units	PQL	Dilution	DLR	Prep Date/Time	Analysis Date/Time
TPH as Diesel (C10-C28)	EPA 8015B	ND	µg/L	50	1	50	02/12/09	02/13/09
TPH as Gasoline (C6-C10)	EPA 8015B	ND	µg/L	50	1	50	02/13/09	02/14/09
Benzene	EPA 8021B	ND	µg/L	0.30	1	0.30	02/13/09	02/14/09
Ethylbenzene	EPA 8021B	ND	µg/L	0.30	1	0.30	02/13/09	02/14/09
Toluene	EPA 8021B	ND	µg/L	0.30	1	0.30	02/13/09	02/14/09
Total Xylenes	EPA 8021B	ND	µg/L	0.30	1	0.30	02/13/09	02/14/09
1,2-Dibromoethane	EPA 8260B	ND	µg/L	5.0	1	5.0	02/12/09	02/13/09
1,2-Dichloroethane	EPA 8260B	ND	µg/L	5.0	1	5.0	02/12/09	02/13/09
Di-isopropyl Ether	EPA 8260B	ND	µg/L	5.0	1	5.0	02/12/09	02/13/09
Ethyl t-Butyl Ether	EPA 8260B	ND	µg/L	5.0	1	5.0	02/12/09	02/13/09
Methyl-t-Butyl Ether	EPA 8260B	62	µg/L	5.0	1	5.0	02/12/09	02/13/09
t-Amyl Methyl Ether	EPA 8260B	ND	µg/L	5.0	1	5.0	02/12/09	02/13/09
tert-Butyl Alcohol	EPA 8260B	ND	µg/L	50	1	50	02/12/09	02/13/09

Surrogate

Tetracosane	EPA 8015B	120	% Rec	-	1	N/A	02/12/09	02/13/09
Fluorobenzene	EPA 8021B	73	% Rec	-	1	N/A	02/13/09	02/14/09
Toluene-d8	EPA 8260B	100	% Rec	-	1	N/A	02/12/09	02/13/09

mg/L: Milligrams/Liter (ppm)
mg/Kg: Milligrams/Kilogram (ppm)
µg/L: Micrograms/Liter (ppb)
µg/Kg: Micrograms/Kilogram (ppb)
%Rec: Percent Recovered (surrogates)

PQL: Practical Quantitation Limit
DLR: Detection Limit for Reporting
: PQL x Dilution
ND: None Detected at DLR
pCi/L: Picocurie per Liter

H: Analyzed outside of hold time
P: Preliminary result
S: Suspect result. See Case Narrative for comments.
E: Analysis performed by External laboratory.
See External Laboratory Report attachments.
MDC: Min Detectable Concentration

Report Authentication Code:



QC Summary Report

02/20/2009



BSK Submission : 2009020847
Client : BSK Associates - Sacramento
Date Submitted : 02/11/2009
Project ID : E0805401S

NELAP Certificate #04227CA
ELAP Certificate #1180

Project Desc : Unocal Castro Valley

BSK StarLims Run #: 167518



Analyst Initials: AMYN

Method Number: 8260OX

Analyte Results

Analyte	QC Type	Matrix Spike ID	Result	Units	% Rec or RPD	Spike RPD	Spk Conc	Matrix Conc	UCL	LCL	Date	
1,2-Dibromoethane	LCS	N/A	12	µg/L	98		12.5	ND	130	80	02/13/09	Acceptable
1,2-Dichloroethane	LCS	N/A	12	µg/L	99		12.5	ND	130	75	02/13/09	Acceptable
Di-isopropyl Ether	LCS	N/A	13	µg/L	100		12.5	ND	130	80	02/13/09	Acceptable
Ethyl t-Butyl Ether	LCS	N/A	13	µg/L	102		12.5	ND	130	70	02/13/09	Acceptable
Methyl-t-Butyl Ether	LCS	N/A	13	µg/L	103		12.5	ND	130	80	02/13/09	Acceptable
t-Amyl Methyl Ether	LCS	N/A	12	µg/L	100		12.50	ND	140	60	02/13/09	Acceptable
tert-Butyl Alcohol	LCS	N/A	140	µg/L	109		125.0	ND	140	60	02/13/09	Acceptable
1,2-Dibromoethane	LCSD	N/A	13	µg/L	101	3	12.5	ND	130	80	02/13/09	Acceptable
1,2-Dichloroethane	LCSD	N/A	12	µg/L	98	0.48	12.5	ND	130	75	02/13/09	Acceptable
Di-isopropyl Ether	LCSD	N/A	12	µg/L	98	2.6	12.50	ND	130	80	02/13/09	Acceptable
Ethyl t-Butyl Ether	LCSD	N/A	12	µg/L	99	3	12.5	ND	130	70	02/13/09	Acceptable
Methyl-t-Butyl Ether	LCSD	N/A	12	µg/L	98	5	12.5	ND	130	80	02/13/09	Acceptable
t-Amyl Methyl Ether	LCSD	N/A	12	µg/L	99	0.24	12.5	ND	140	60	02/13/09	Acceptable
tert-Butyl Alcohol	LCSD	N/A	130	µg/L	101	7	125.0	ND	140	60	02/13/09	Acceptable
1,2-Dibromoethane	MS	1085805	12	µg/L	94		12.5	ND	130	80	02/13/09	Acceptable
1,2-Dichloroethane	MS	1085805	11	µg/L	85		12.5	ND	130	75	02/13/09	Acceptable
Di-isopropyl Ether	MS	1085805	11	µg/L	88		12.5	ND	130	70	02/13/09	Acceptable
Ethyl t-Butyl Ether	MS	1085805	11	µg/L	86		12.5	ND	130	70	02/13/09	Acceptable
Methyl-t-Butyl Ether	MS	1085805	65	µg/L	16		12.5	62	145	70	02/13/09	OOS-Low
t-Amyl Methyl Ether	MS	1085805	11	µg/L	87		12.5	ND	125	70	02/13/09	Acceptable
tert-Butyl Alcohol	MS	1085805	100	µg/L	82		125.0	ND	140	70	02/13/09	Acceptable
1,2-Dibromoethane	MSD	1085805	12	µg/L	100	5.3	12.5	ND	130	80	02/13/09	Acceptable
1,2-Dichloroethane	MSD	1085805	12	µg/L	97	13	12.5	ND	130	75	02/13/09	Acceptable
Di-isopropyl Ether	MSD	1085805	13	µg/L	104	16	12.5	ND	130	70	02/13/09	Acceptable
Ethyl t-Butyl Ether	MSD	1085805	13	µg/L	103	18	12.5	ND	130	70	02/13/09	Acceptable
Methyl-t-Butyl Ether	MSD	1085805	76	µg/L	109	16	12.5	62	145	70	02/13/09	Acceptable
t-Amyl Methyl Ether	MSD	1085805	13	µg/L	102	15	12.5	ND	125	70	02/13/09	Acceptable
tert-Butyl Alcohol	MSD	1085805	130	µg/L	106	24	125.0	ND	140	70	02/13/09	Acceptable
1,2-Dibromoethane	RBLK	N/A	ND	µg/L	< 5.0				5.0	N/A	02/13/09	Acceptable
1,2-Dichloroethane	RBLK	N/A	ND	µg/L	< 5.0				5.0	N/A	02/13/09	Acceptable
Di-isopropyl Ether	RBLK	N/A	ND	µg/L	< 5.0				5.0	N/A	02/13/09	Acceptable
Ethyl t-Butyl Ether	RBLK	N/A	ND	µg/L	< 5.0				5.0	N/A	02/13/09	Acceptable
Methyl-t-Butyl Ether	RBLK	N/A	ND	µg/L	< 5.0				5.0	N/A	02/13/09	Acceptable
t-Amyl Methyl Ether	RBLK	N/A	ND	µg/L	< 5.0				5.0	N/A	02/13/09	Acceptable
tert-Butyl Alcohol	RBLK	N/A	ND	µg/L	< 5.0				5.0	N/A	02/13/09	Acceptable

%Rec: Percent Recovered
RPD: Relative Percent Difference
UCL: Upper Control Limit
LCL: Lower Control Limit
LCS: Laboratory Control Sample
LCSD: Laboratory Control Sample Duplicate
LDUP: Laboratory Sample Duplicate

Parent Sample: Sample used as background matrix for MS/MSD
OOS-High: QC Result Above UCL
OOS-Low: QC Result Below LCL
MS: Matrix Spike
MSD: Matrix Spike Duplicate
RBLK: Reagent (Method) Blank

QC Summary Report

02/20/2009



NELAP Certificate #04227CA
ELAP Certificate #1180

BSK Submission : 2009020847
Client : BSK Associates - Sacramento
Date Submitted : 02/11/2009
Project ID : E0805401S

Project Desc : Unocal Castro Valley

BSK StarLims Run #: 167518



Analyst Initials: AMYN

Method Number: 8260OX

Run	Test	Analyte	Comment
167518	8260OX	MTBE	MS recovery was affected by the matrix.

Surrogate Results

Analyte	QC Type	Surr. Result	UCL	LCL	Date
Toluene-d8	LCS N/A	100 % Rec	100	120	80 02/13/09 Acceptable
Toluene-d8	LCSD N/A	100 % Rec	100	120	80 02/13/09 Acceptable
Toluene-d8	MS 1085805	100 % Rec	100	130	80 02/13/09 Acceptable
Toluene-d8	MSD 1085805	100 % Rec	100	130	80 02/13/09 Acceptable
Toluene-d8	RBLK N/A	100 % Rec	N/A	N/A	02/13/09 Acceptable

StarLims Run 167518 includes the following BSK Sample ID# :

1084228 1084229 1084230 1085804 1085805 1086161 1086162 1086163 1086164 1086165

BSK StarLims Run #: 167537



Analyst Initials: PAOY

Method Number: TPHD_LL

Analyte Results

Analyte	QC Type	Matrix Spike ID	Result	Units	% Rec or RPD	Spike RPD	Spk Conc	Matrix Conc	UCL	LCL	Date
TPH as Diesel (C10-C28)	LCS	N/A	3100	µg/L	123		2500	ND	130	70	02/13/09 Acceptable
TPH as Diesel (C10-C28)	LCSD	N/A	3100	µg/L	124	0.46	2500	ND	130	70	02/13/09 Acceptable
TPH as Diesel (C10-C28)	MS	1083937	3100	µg/L	121		2500	100	130	70	02/13/09 Acceptable
TPH as Diesel (C10-C28)	RBLK	N/A	ND	µg/L	< 50				50	N/A	02/13/09 Acceptable

Surrogate Results

Analyte	QC Type	Surr. Result	UCL	LCL	Date
Tetracosane	LCS N/A	160 % Rec	150	189	45 02/13/09 Acceptable
Tetracosane	LCSD N/A	240 % Rec	150	189	45 02/13/09 OOS-High
Tetracosane	MS 1083937	91 % Rec	69	189	45 02/13/09 Acceptable
Tetracosane	RBLK N/A	150 % Rec	N/A	N/A	02/13/09 Acceptable

StarLims Run 167537 includes the following BSK Sample ID# :

1083937 1084200 1084227 1084228 1084229 1084230 1085804 1085805 1086278 1086279 1086280 1086281

BSK StarLims Run #: 167583



Analyst Initials: PAOY

Method Number: BTEX_LL

Analyte Results

Analyte	QC Type	Matrix Spike ID	Result	Units	% Rec or RPD	Spike RPD	Spk Conc	Matrix Conc	UCL	LCL	Date
---------	---------	-----------------	--------	-------	--------------	-----------	----------	-------------	-----	-----	------

%Rec: Percent Recovered
RPD: Relative Percent Difference
UCL: Upper Control Limit
LCL: Lower Control Limit
LCS: Laboratory Control Sample
LCSD: Laboratory Control Sample Duplicate
LDUP: Laboratory Sample Duplicate

Parent Sample: Sample used as background matrix for MS/MSD
OOS-High: QC Result Above UCL
OOS-Low: QC Result Below LCL
MS: Matrix Spike
MSD: Matrix Spike Duplicate
RBLK: Reagent (Method) Blank

QC Summary Report

02/20/2009



BSK Submission : 2009020847
Client : BSK Associates - Sacramento
Date Submitted : 02/11/2009
Project ID : E0805401S

NELAP Certificate #04227CA
ELAP Certificate #1180

Project Desc : Unocal Castro Valley

BSK StarLims Run #: 167583



Analyst Initials: PAOY

Method Number: BTEX_LL

Analyte	QC Type	Matrix Spike ID	Result	Units	% Rec or RPD	Spike RPD	Spk Conc	Matrix Conc	UCL	LCL	Date	
Benzene	LCS	N/A	20	µg/L	98		20	ND	130	70	02/13/09	Acceptable
Ethylbenzene	LCS	N/A	20	µg/L	100		20	ND	130	70	02/13/09	Acceptable
Toluene	LCS	N/A	19	µg/L	96		20	ND	130	70	02/13/09	Acceptable
Total Xylenes	LCS	N/A	59	µg/L	98		60	ND	130	70	02/13/09	Acceptable
TPH as Gasoline (C6-C10)	LCS	N/A	120	µg/L	98		120	ND	130	70	02/13/09	Acceptable
Benzene	LCSD	N/A	21	µg/L	103	4.8	20	ND	130	70	02/14/09	Acceptable
Ethylbenzene	LCSD	N/A	21	µg/L	106	5.4	20	ND	130	70	02/14/09	Acceptable
Toluene	LCSD	N/A	20	µg/L	101	4.6	20	ND	130	70	02/14/09	Acceptable
Total Xylenes	LCSD	N/A	63	µg/L	104	6.2	60	ND	130	70	02/14/09	Acceptable
TPH as Gasoline (C6-C10)	LCSD	N/A	120	µg/L	103	5	120	ND	130	70	02/14/09	Acceptable
Benzene	MS	1083976	11	µg/L	110		10	ND	130	70	02/14/09	Acceptable
Ethylbenzene	MS	1083976	11	µg/L	111		10	ND	130	70	02/14/09	Acceptable
Toluene	MS	1083976	11	µg/L	106		10	ND	130	70	02/14/09	Acceptable
Total Xylenes	MS	1083976	33	µg/L	110		30	ND	130	70	02/14/09	Acceptable
TPH as Gasoline (C6-C10)	MS	1083976	65	µg/L	108		60	ND	130	70	02/14/09	Acceptable
Benzene	RBLK	N/A	ND	µg/L	< 0.30				0.30	N/A	02/13/09	Acceptable
Ethylbenzene	RBLK	N/A	ND	µg/L	< 0.30				0.30	N/A	02/13/09	Acceptable
Toluene	RBLK	N/A	ND	µg/L	< 0.30				0.30	N/A	02/13/09	Acceptable
Total Xylenes	RBLK	N/A	ND	µg/L	< 0.30				0.30	N/A	02/13/09	Acceptable
TPH as Gasoline (C6-C10)	RBLK	N/A	ND	µg/L	< 50				50	N/A	02/13/09	Acceptable

Surrogate Results

Analyte	QC Type	Surr. Result	UCL	LCL	Date	
Fluorobenzene	LCS	N/A 97 % Rec	100	130	70	02/13/09 Acceptable
Fluorobenzene	LCSD	N/A 100 % Rec	100	130	70	02/14/09 Acceptable
Fluorobenzene	MS	1083976 110 % Rec	100	130	70	02/14/09 Acceptable
Fluorobenzene	RBLK	N/A 100 % Rec	N/A	N/A	02/13/09	Acceptable

StarLims Run 167583 includes the following BSK Sample ID#:

1083937 1083976 1084200 1084227 1084228 1084229 1084230 1085804 1085805 1086581 1086582 1086583 1086584

Approved by: Maia C Hamel

%Rec: Percent Recovered
RPD: Relative Percent Difference
UCL: Upper Control Limit
LCL: Lower Control Limit
LCS: Laboratory Control Sample
LCSD: Laboratory Control Sample Duplicate
LDUP: Laboratory Sample Duplicate

Parent Sample: Sample used as background matrix for MS/MSD
OOS-High: QC Result Above UCL
OOS-Low: QC Result Below LCL
MS: Matrix Spike
MSD: Matrix Spike Duplicate
RBLK: Reagent (Method) Blank

Sample Integrity

Pg. 1 of 2

2009020847

02/11/2009

BSK S
21120

TAT: Standard

Date Received

2/11/09



Section 1- Sampled Same Day
 Sample Transport: Walk In SJVC BSK-Courier Transported In: Ice Chest Box Hand
 Has chilling process begun? Y N Samples Received: Chilled to Touch / Ambient On Ice

Section 2- Sampled Previously
 Sample Transport: CAO UPS SJVC Walk In BSK-Courier GSO Fed Exp. Other: _____
 No. Coolers/Ice Chests: _____ Temperature(s): _____
 Was Temperature In Range: Y N Received On Ice Wet Blue
 Describe type of packing materials: Bubble Wrap Foam Packing Peanuts Paper Other: _____
 Were ice chest custody seals present? Y N Intact: Y N

Section 3- COC Info.

	Completed		Info From Container	Completed		Info From Container
	Yes	No		Yes	No	
Was COC Received	<u>Y</u>					Analysis Requested <u>Y</u>
Date Sampled	<u>Y</u>					Any hold times less than 72hr <u>Y</u>
Time Sampled	<u>Y</u>					Client Name <u>Y</u>
Sample ID	<u>Y</u>					Address <u>Y</u>
Special Storage/Handling Ins.	<u>Y</u>					Telephone # <u>Y</u>

Section 4- Bottles / Analysis

	Yes	No	N/A	Comment
Did all bottles arrive unbroken and intact?:	<u>Y</u>			
Were bottle custody seals present?		<u>Y</u>		
Were bottle custody seals intact?		<u>Y</u>		
Did all bottle labels agree with COC?:	<u>Y</u>			
Were correct containers used for the tests requested?:	<u>Y</u>			
Were correct preservations used for the tests requested?:	<u>Y</u>			
Was a sufficient amount of sample sent for tests indicated?:	<u>Y</u>			
Were bubbles present in VOA Vials?: (Volatile Methods Only)		<u>Y</u>		
Were Ascorbic Acid Bottles received with the VOAs		<u>Y</u>		

Section 5- Comments / Discrepancies

Sample(s) Split/Preserve: Yes No Container: _____ Preservation: _____ Init.: _____

Was Client Service Rep. notified of discrepancies: Yes No N/A CSR: _____ Notified By: _____

Explanations / Comments

Report Comment Entered:

Sample Integrity

Pg 22 of 2

2009020847 02/11/2009
BSK S TAT: Standard

SR-FL-0002-02

BSK Bottles Yes No

211120



8oz (A) 16oz (B) 32oz (C) Amber Glass (AG)

PRE LOG #:

Container(s) Received	1-2				
Bacti Na ₂ S ₂ O ₃					
None (p) ^{White Cap}					
None (p) ^{Blue Cap}					
HNO ₃ (p) ^{Red Cap}					
H ₂ SO ₄ (p) ^{Yellow Cap}					
NaOH (p) ^{Green Cap}					
Other:					
Dissolved Oxygen 300ml (g)					
250ml (AG) None					
250ml (AG) H ₂ SO ₄ COD ^{Yellow Label}					
250ml (AG) Na ₂ S ₂ O ₃ 515,547 ^{Blue Label}					
250ml (AG) Na ₂ S ₂ O ₃ + MCAA 531.1 ^{Orange Label}					
250ml (AG) NH ₄ Cl 552 ^{Purple Label}					
250ml (AG) EDA DBPs ^{Brown Label}					
250ml (AG) Other:					
500ml (AG) None					
500ml (AG) H ₂ SO ₄ TPH-Diesel ^{Yellow Label}	1				
1 Liter (AG) None					
1 Liter (AG) H ₂ SO ₄ O&G ^{Yellow Label}					
1 Liter (AG) Na ₂ S ₂ O ₃ 548 / 525 / 521 ^{Blue Label}					
1 Liter (P) Na ₂ S ₂ O ₃ + H ₂ SO ₄ 549					
1 Liter (AG) NaOH+ZnAc Sulfide					
1 Liter (AG) Ascorbic/EDTA/Pot Citrate 527 ^{Grey Label}					
1 Liter (AG) CuSO ₄ /Trizma 529 ^{Turquoise Label}					
1 Liter (AG) Na ₂ SO ₃ / HCL 525 UCMR ^{Neon Green Label}					
1 Liter (AG) Ammonium Chloride 535 ^{Purple Label}					
40ml VOA Vial Clear - HCL	6				
40ml VOA Vial Amber - Na ₂ S ₂ O ₃					
40ml VOA Vial Clear - None					
40ml VOA Vial Clear - Na ₂ S ₂ O ₃ 504, 505					
40ml VOA Vial Clear - H ₃ PO ₄					
Other:					
Asbestos 32oz Plastic/Foil					
Radiological GA / GB (1/2 Gal Plastic)					
Radiological 226 / 228 (32 oz plastic N-BSK)					
Radon 200ml Clear (g)					
Low Level Hg/Metals Double Baggie					
THM-FP 4-40ml VOA None					
250 Clear Glass Jar					
500 Clear Glass Jar					
1 Liter Clear Glass Jar					
Plastic Bag					
Soil Tube Brass / Steel / Plastic					
Tedlar Bags					

Handwritten signature and date: RA 2/11/09

BSK ANALYTICAL LABORATORIES

1414 Stanislaus, Fresno CA 93706
 (559) 497-2888, (800) 877-8310, FAX (559) 485-6935

Page: 1 of 1

BSK Submission:
 COC Number:
 Global ID Number: T0600101370

2009020847 02/11/2009
 BSK S TAT: Standard
 211120



Facility/Project Name		Report Attention		Method Preserved					BTEX/TPH-G (8020/8015M)	TPH-Diesel (8015M)	Fuel Oxygenates (8260B)	Lead Scavengers (8260B)	Rush Priority (1-Day, 2-Day, 5-Day)
Unocal Castro Valley		Jeff Yeazell		HCl	HNO3	H2SO4	NONE	OTHER (List)					
Address		BSK Job No.:											
City, State, Zip		Copy to:											
Phone		FAX											
Lab Use Only	Sampling Info		Sampled by:										
S	C	Date	Time	Field Point Name									
1	27	2/11/09	1120	MW-3	✓		✓		✓	✓	✓	✓	1085804
2	27	2/11/09	1220	MW-2	✓		✓		✓	✓	✓	✓	1085805
/													

QC Report Type: Level 2 3 4

Formal COC Required:

Electronic Data Format Required:

Email EDF To: jyeazell@bskinc.com

Low Level Fuel Oxygenates Detection Limits Req:

Signature	Print Name	Company	Date/Time
	DAVID J. CUEVAS	BSK	2/11/09 1637
Received / Relinquished by:			
Received / Relinquished by:			
Received / Relinquished by:			
	Ryan Harris	BSK	2/11/09 1637



1414 Stanislaus Street
Fresno, California 93706
(559) 497-2888
Fax (559) 485-6935

BSK Submission Number: 2009020490

AMENDED REPORT

03/16/2009

Jeff Yeazell
BSK Associates - Sacramento
3140 Gold Camp Drive Suite 160
Rancho Cordova, CA 95670

Dear Jeff Yeazell,

Once again, we would like to thank you for selecting BSK Analytical Laboratories for your analytical testing needs. Amendments have been made to the original BSK Analytical report identified above. The pertinent amended pages are enclosed, along with a copy of the original Chain of Custody for this submission. Listed below are the amendments that have been made:

Report amended to reflect correct values for TPH-G. (TPH-G for MW-6 changed from ND to 97 ppb and TPH-G for MW-7 changed from 320 ppb to 400 ppb)

If additional clarification of any information is required, please contact your Client Services Representative, Dan Larkin, at (800) 877-8310 or (559) 497-2888.

BSK ANALYTICAL LABORATORIES

A handwritten signature in black ink, appearing to read "Dan Larkin", written over a horizontal line.

Dan Larkin

Client Services Representative

A handwritten signature in black ink, written over a horizontal line.

Quality Control Reviewer



Jeff Yeazell
BSK Associates - Sacramento
3140 Gold Camp Drive Suite 160
Rancho Cordova, CA 95670

BSK Submission #: 2009020490

BSK Sample ID #: 1084227

Report Issue Date: 03/16/2009

Project ID: E0805401S

Project Desc: Unocal Castro Valley

Submission Comments:

Sample Type: Liquid

Date Sampled: 02/06/2009

Sample Description: MW-5

Time Sampled: 1205

Sample Comments:

Date Received: 02/06/2009

Organics

Analyte	Method	Result	Units	PQL	Dilution	DLR	Prep Date/Time	Analysis Date/Time
TPH as Diesel (C10-C28)	EPA 8015B	ND	µg/L	50	1	50	02/12/09	02/13/09
TPH as Gasoline (C6-C10)	EPA 8015B	ND	µg/L	50	1	50	02/13/09	02/14/09
Benzene	EPA 8021B	ND	µg/L	0.30	1	0.30	02/13/09	02/14/09
Ethylbenzene	EPA 8021B	ND	µg/L	0.30	1	0.30	02/13/09	02/14/09
Toluene	EPA 8021B	ND	µg/L	0.30	1	0.30	02/13/09	02/14/09
Total Xylenes	EPA 8021B	ND	µg/L	0.30	1	0.30	02/13/09	02/14/09
1,2-Dibromoethane	EPA 8260B	ND	µg/L	5.0	1	5.0	02/12/09	02/13/09
1,2-Dichloroethane	EPA 8260B	ND	µg/L	5.0	1	5.0	02/12/09	02/13/09
Di-isopropyl Ether	EPA 8260B	ND	µg/L	5.0	1	5.0	02/12/09	02/13/09
Ethyl t-Butyl Ether	EPA 8260B	ND	µg/L	5.0	1	5.0	02/12/09	02/13/09
Methyl-t-Butyl Ether	EPA 8260B	ND	µg/L	5.0	1	5.0	02/12/09	02/13/09
t-Amyl Methyl Ether	EPA 8260B	ND	µg/L	5.0	1	5.0	02/12/09	02/13/09
tert-Butyl Alcohol	EPA 8260B	ND	µg/L	50	1	50	02/12/09	02/13/09

Surrogate

Tetracosane	EPA 8015B	120	% Rec	-	1	N/A	02/12/09	02/13/09
Fluorobenzene	EPA 8021B	100	% Rec	-	1	N/A	02/13/09	02/14/09
Toluene-d8	EPA 8260B	100	% Rec	-	1	N/A	02/12/09	02/13/09

mg/L: Milligrams/Liter (ppm)
mg/Kg: Milligrams/Kilogram (ppm)
µg/L: Micrograms/Liter (ppb)
µg/Kg: Micrograms/Kilogram (ppb)
%Rec: Percent Recovered (surrogates)

PQL: Practical Quantitation Limit
DLR: Detection Limit for Reporting
: PQL x Dilution
ND: None Detected at DLR
pCi/L: Picocurie per Liter

H: Analyzed outside of hold time
P: Preliminary result
S: Suspect result. See Case Narrative for comments.
E: Analysis performed by External laboratory.
See External Laboratory Report attachments.
MDC: Min Detectable Concentration

Report Authentication Code:



Jeff Yeazell
BSK Associates - Sacramento
3140 Gold Camp Drive Suite 160
Rancho Cordova, CA 95670

BSK Submission #: 2009020490

BSK Sample ID #: 1084228

Report Issue Date: 03/16/2009

Project ID: E0805401S

Project Desc: Unocal Castro Valley

Submission Comments:

Sample Type: Liquid

Sample Description: MW-6

Sample Comments:

Date Sampled: 02/06/2009

Time Sampled: 1310

Date Received: 02/06/2009

Organics

Analyte	Method	Result	Units	PQL	Dilution	DLR	Prep Date/Time	Analysis Date/Time
TPH as Diesel (C10-C28)	EPA 8015B	ND	µg/L	50	1	50	02/12/09	02/13/09
TPH as Gasoline (C6-C10)	EPA 8015B	97	µg/L	50	1	50	02/13/09	02/14/09
Benzene	EPA 8021B	ND	µg/L	0.30	1	0.30	02/13/09	02/14/09
Ethylbenzene	EPA 8021B	ND	µg/L	0.30	1	0.30	02/13/09	02/14/09
Toluene	EPA 8021B	ND	µg/L	0.30	1	0.30	02/13/09	02/14/09
Total Xylenes	EPA 8021B	ND	µg/L	0.30	1	0.30	02/13/09	02/14/09
1,2-Dibromoethane	EPA 8260B	ND	µg/L	5.0	1	5.0	02/12/09	02/13/09
1,2-Dichloroethane	EPA 8260B	ND	µg/L	5.0	1	5.0	02/12/09	02/13/09
Di-isopropyl Ether	EPA 8260B	ND	µg/L	5.0	1	5.0	02/12/09	02/13/09
Ethyl t-Butyl Ether	EPA 8260B	ND	µg/L	5.0	1	5.0	02/12/09	02/13/09
Methyl-t-Butyl Ether	EPA 8260B	200	µg/L	5.0	20	100	02/13/09	02/13/09
t-Amyl Methyl Ether	EPA 8260B	ND	µg/L	5.0	1	5.0	02/12/09	02/13/09
tert-Butyl Alcohol	EPA 8260B	ND	µg/L	50	1	50	02/12/09	02/13/09

Surrogate

Tetracosane	EPA 8015B	98	% Rec	-	1	N/A	02/12/09	02/13/09
Fluorobenzene	EPA 8021B	100	% Rec	-	1	N/A	02/13/09	02/14/09
Toluene-d8	EPA 8260B	100	% Rec	-	1	N/A	02/12/09	02/13/09

mg/L: Milligrams/Liter (ppm)
mg/Kg: Milligrams/Kilogram (ppm)
µg/L: Micrograms/Liter (ppb)
µg/Kg: Micrograms/Kilogram (ppb)
%Rec: Percent Recovered (surrogates)

PQL: Practical Quantitation Limit
DLR: Detection Limit for Reporting
: PQL x Dilution
ND: None Detected at DLR
pCi/L: Picocurie per Liter

H: Analyzed outside of hold time
P: Preliminary result
S: Suspect result. See Case Narrative for comments.
E: Analysis performed by External laboratory.
See External Laboratory Report attachments.
MDC: Min Detectable Concentration

Report Authentication Code:



Certificate of Analysis

NELAP Certificate #04227CA

ELAP Certificate #1180

Jeff Yeazell
BSK Associates - Sacramento
3140 Gold Camp Drive Suite 160
Rancho Cordova, CA 95670

BSK Submission #: 2009020490

BSK Sample ID #: 1084229

Report Issue Date: 03/16/2009

Project ID: E0805401S

Project Desc: Unocal Castro Valley

Submission Comments:

Sample Type: Liquid

Date Sampled: 02/06/2009

Sample Description: MW-7

Time Sampled: 1410

Sample Comments:

Date Received: 02/06/2009

Organics

Analyte	Method	Result	Units	PQL	Dilution	DLR	Prep Date/Time	Analysis Date/Time
TPH as Diesel (C10-C28)	EPA 8015B	ND	µg/L	50	1	50	02/12/09	02/13/09
TPH as Gasoline (C6-C10)	EPA 8015B	400	µg/L	50	1	50	02/13/09	02/14/09
Benzene	EPA 8021B	ND	µg/L	0.30	1	0.30	02/13/09	02/14/09
Ethylbenzene	EPA 8021B	ND	µg/L	0.30	1	0.30	02/13/09	02/14/09
Toluene	EPA 8021B	ND	µg/L	0.30	1	0.30	02/13/09	02/14/09
Total Xylenes	EPA 8021B	ND	µg/L	0.30	1	0.30	02/13/09	02/14/09
1,2-Dibromoethane	EPA 8260B	ND	µg/L	5.0	1	5.0	02/12/09	02/13/09
1,2-Dichloroethane	EPA 8260B	ND	µg/L	5.0	1	5.0	02/12/09	02/13/09
Di-isopropyl Ether	EPA 8260B	ND	µg/L	5.0	1	5.0	02/12/09	02/13/09
Ethyl t-Butyl Ether	EPA 8260B	ND	µg/L	5.0	1	5.0	02/12/09	02/13/09
Methyl-t-Butyl Ether	EPA 8260B	ND	µg/L	5.0	1	5.0	02/12/09	02/13/09
t-Amyl Methyl Ether	EPA 8260B	ND	µg/L	5.0	1	5.0	02/12/09	02/13/09
tert-Butyl Alcohol	EPA 8260B	ND	µg/L	50	1	50	02/12/09	02/13/09

Surrogate

Tetracosane	EPA 8015B	100	% Rec	-	1	N/A	02/12/09	02/13/09
Fluorobenzene	EPA 8021B	99	% Rec	-	1	N/A	02/13/09	02/14/09
Toluene-d8	EPA 8260B	100	% Rec	-	1	N/A	02/12/09	02/13/09

mg/L: Milligrams/Liter (ppm)
mg/Kg: Milligrams/Kilogram (ppm)
µg/L: Micrograms/Liter (ppb)
µg/Kg: Micrograms/Kilogram (ppb)
%Rec: Percent Recovered (surrogates)

PQL: Practical Quantitation Limit
DLR: Detection Limit for Reporting
: PQL x Dilution
ND: None Detected at DLR
pCi/L: Picocurie per Liter

H: Analyzed outside of hold time
P: Preliminary result
S: Suspect result. See Case Narrative for comments.
E: Analysis performed by External laboratory.
See External Laboratory Report attachments.
MDC: Min Detectable Concentration

Report Authentication Code:



Certificate of Analysis

NELAP Certificate #04227CA

ELAP Certificate #1180

Jeff Yeazell
BSK Associates - Sacramento
3140 Gold Camp Drive Suite 160
Rancho Cordova, CA 95670

BSK Submission #: 2009020490

BSK Sample ID #: 1084230

Report Issue Date: 03/16/2009

Project ID: E0805401S

Project Desc: Unocal Castro Valley

Submission Comments:

Sample Type: Liquid

Date Sampled: 02/06/2009

Sample Description: MW-101

Time Sampled: 1625

Sample Comments:

Date Received: 02/06/2009

Organics

Analyte	Method	Result	Units	PQL	Dilution	DLR	Prep Date/Time	Analysis Date/Time
TPH as Diesel (C10-C28)	EPA 8015B	3600	µg/L	50	1	50	02/12/09	02/13/09
TPH as Gasoline (C6-C10)	EPA 8015B	ND	µg/L	50	1	50	02/13/09	02/14/09
Benzene	EPA 8021B	ND	µg/L	0.30	1	0.30	02/13/09	02/14/09
Ethylbenzene	EPA 8021B	ND	µg/L	0.30	1	0.30	02/13/09	02/14/09
Toluene	EPA 8021B	ND	µg/L	0.30	1	0.30	02/13/09	02/14/09
Total Xylenes	EPA 8021B	ND	µg/L	0.30	1	0.30	02/13/09	02/14/09
1,2-Dibromoethane	EPA 8260B	ND	µg/L	5.0	1	5.0	02/12/09	02/13/09
1,2-Dichloroethane	EPA 8260B	ND	µg/L	5.0	1	5.0	02/12/09	02/13/09
Di-isopropyl Ether	EPA 8260B	ND	µg/L	5.0	1	5.0	02/12/09	02/13/09
Ethyl t-Butyl Ether	EPA 8260B	ND	µg/L	5.0	1	5.0	02/12/09	02/13/09
Methyl-t-Butyl Ether	EPA 8260B	630	µg/L	5.0	50	250	02/13/09	02/13/09
t-Amyl Methyl Ether	EPA 8260B	ND	µg/L	5.0	1	5.0	02/12/09	02/13/09
tert-Butyl Alcohol	EPA 8260B	ND	µg/L	50	1	50	02/12/09	02/13/09

Surrogate

Tetracosane	EPA 8015B	110	% Rec	-	1	N/A	02/12/09	02/13/09
Fluorobenzene	EPA 8021B	100	% Rec	-	1	N/A	02/13/09	02/14/09
Toluene-d8	EPA 8260B	100	% Rec	-	1	N/A	02/12/09	02/13/09

LUFT Comments

TPH as Diesel (C10-C28) Higher boiling point hydrocarbons decreased relative to standard

mg/L: Milligrams/Liter (ppm)
mg/Kg: Milligrams/Kilogram (ppm)
µg/L: Micrograms/Liter (ppb)
µg/Kg: Micrograms/Kilogram (ppb)
%Rec: Percent Recovered (surrogates)

PQL: Practical Quantitation Limit
DLR: Detection Limit for Reporting
: PQL x Dilution
ND: None Detected at DLR
pCi/L: Picocurie per Liter

H: Analyzed outside of hold time
P: Preliminary result
S: Suspect result. See Case Narrative for comments.
E: Analysis performed by External laboratory.
See External Laboratory Report attachments.
MDC: Min Detectable Concentration

Report Authentication Code:



Sample Integrity

Pg. 1 of 2

2009020490

02/06/2009

BSK S
26138

TAT: Standard

Date Received 2/6/09



Section 1- Sampled Same Day
 Sample Transport: Walk In SJVC BSK-Courier Transported In: Ice Chest Box Hand
 Has chilling process begun? Y N Samples Received: Chilled to Touch / Ambient / On Ice

Section 2- Sampled Previously
 Sample Transport: CAO UPS SJVC Walk-In BSK-Courier GSO Fed Exp. Other:
 No. Coolers/Ice Chests: _____ Temperature(s): _____
 Was Temperature In Range: Y N Received On Ice: Wet Blue
 Describe type of packing materials: Bubble Wrap Foam Packing Peanuts Paper Other:
 Were ice chest custody seals present? Y N Intact: Y N

Section 3- COC Info.	Completed		Info From Container	Completed		Info From Container
	Yes	No		Yes	No	
Was COC Received	—		Analysis Requested	—		
Date Sampled	—		Any hold times less than 72hr	—		
Time Sampled	—		Client Name	—		
Sample ID	—		Address	—		
Special Storage/Handling Ins.	—		Telephone #	—		

Section 4- Bottles / Analysis	Yes	No	N/A	Comment
Did all bottles arrive unbroken and intact?:	—			
Were bottle custody seals present?			—	
Were bottle custody seals intact?			—	
Did all bottle labels agree with COC?:	—			
Were correct containers used for the tests requested?:	—			
Were correct preservations used for the tests requested?:	—			
Was a sufficient amount of sample sent for tests indicated?:	—			
Were bubbles present in VOA Vials?: (Volatile Methods Only)			—	
Were Ascorbic Acid Bottles received with the VOAs			—	

Section 5- Comments / Discrepancies
 Sample(s) Split/Preserve: Yes No Container: _____ Preservation: _____ Init.: _____
 Was Client Service Rep. notified of discrepancies: Yes No N/A CSR: _____ Notified By: _____
 Explanations / Comments

 Report Comment Entered:

Labeled by: [Signature]

Labels checked by: [Signature]

Sample Integrity Pg 2 of 2

2009020490 02/06/2009

SR-FL-0002-02

BSK Bottles Yes No

BSK S

TAT: Standard

26138

8oz (A) 16oz (B) 32oz (C) Amber Glass (AG)



Container(s) Received									
Bacti-Na ₂ S ₂ O ₃									
None (p) <small>White Cap</small>									
None (p) <small>Blue Cap</small>									
HNO ₃ (p) <small>Red Cap</small>									
H ₂ SO ₄ (p) <small>Yellow Cap</small>									
NaOH (p) <small>Green Cap</small>									
Other:									
Dissolved Oxygen 300ml (g)									
250ml (AG) None									
250ml (AG) H ₂ SO ₄ COD <small>Yellow Label</small>									
250ml (AG) Na ₂ S ₂ O ₃ 515, 547 <small>Blue Label</small>									
250ml (AG) Na ₂ S ₂ O ₃ + MCAA 531.1 <small>Orange Label</small>									
250ml (AG) NH ₄ Cl 552 <small>Purple Label</small>									
250ml (AG) EDA DBPs <small>Brown Label</small>									
250ml (AG) Other:									
500ml (AG) None									
500ml (AG) H ₂ SO ₄ TPH-Diesel <small>Yellow Label</small>									
1 Liter (AG) None									
1 Liter (AG) H ₂ SO ₄ O&G <small>Yellow Label</small>									
1 Liter (AG) Na ₂ S ₂ O ₃ 548 / 525 / 521 <small>Blue Label</small>									
1 Liter (P) Na ₂ S ₂ O ₃ + H ₂ SO ₄ 549									
1 Liter (AG) NaOH+ZnAc Sulfide									
1 Liter (AG) Ascorbic/EDTA/Pot Citrate 527 <small>Grey Label</small>									
1 Liter (AG) CuSO ₄ /Trizma 529 <small>Turquoise Label</small>									
1 Liter (AG) Na ₂ SO ₃ / HCL 525 UCMR <small>Neon Green Label</small>									
1 Liter (AG) Ammonium Chloride 535 <small>Purple Label</small>									
40ml VOA Vial Clear - HCL									
40ml VOA Vial Amber - Na ₂ S ₂ O ₃									
40ml VOA Vial Clear - None									
40ml VOA Vial Clear - Na ₂ S ₂ O ₃ 504, 505									
40ml VOA Vial Clear - H ₃ PO ₄									
Other:									
Asbestos 32oz Plastic/Foil									
Radiological GA / GB (1/2 Gal Plastic)									
Radiological 226 / 228 (32 oz plastic N-BSK)									
Radon 200ml Clear (g)									
Low Level Hg/Metals Double Baggie									
THM-FP 4-40ml VOA None									
250 Clear Glass Jar									
500 Clear Glass Jar									
1 Liter Clear Glass Jar									
Plastic Bag									
Soil Tube Brass / Steel / Plastic									
Tedlar Bags									

1-4

1

6

[Handwritten signature and date]
 2/6/09

BSK ANALYTICAL LABORATORIES

1414 Stanislaus, Fresno CA 93706
 (559) 497-2888, (800) 877-8310, FAX (559) 485-6935

Page: 1 of 1

BSK Submission: 26138
 COC Number: T0600101370
 Global ID Number: T0600101370

2009020490 02/06/2009
 BSK S TAT: Standard
 26138



Facility/Project Name		Report Attention		Method Preserved						BTEX/TPH-G (8020/8015M)	TPH-Diesel (8015M)	Fuel Oxygenates (8260B)	Lead Scavengers (8260E)	Rush Priority (1-Day, 2-Day, 5)
Unocal Castro Valley		Jeff Yeazell		HCl	HNO3	H2SO4	NONE	OTHER (List)						
Address		BSK Job No.:												
		E0805401S												
City, State, Zip		Copy to:												
Phone		FAX												
Lab Use Only		Sampling Info		Sampled by: <u>DAVID J CUELLAR</u>										
Sl	IC	Date	Time	Field Point Name										
1	7	2/6/09	1205	MW-5	✓		✓		✓	✓	✓	✓		
2			1310	MW-6	✓		✓		✓	✓	✓	✓	1084227	
3			1410	MW-7	✓		✓		✓	✓	✓	✓	228	
4			1625	MW-101	✓		✓		✓	✓	✓	✓	229	
													230	

QC Report Type: Level 2 3 4

Formal COC Required:

Electronic Data Format Required:

Email EDF To: jyeazell@bskinc.com

Low Level Fuel Oxygenates Detection Limits Req:

Signature	Print Name	Company	Date/Time
<i>[Signature]</i>	DAVID J. CUELLAR	BSK	2/6/09 1720
Received / Relinquished by:			
Received / Relinquished by:			
Received / Relinquished by:			
Received / Relinquished by:			
<i>[Signature]</i>	<i>[Signature]</i>	<i>[Signature]</i>	2/6/09 17:20