



Environmental Bio-Systems, Inc.

Innovative Solutions for a Better Environment

www.EBSinfo.com Since 1989

January 26, 2004

Contractor's Lic. # 687236: A-B-C57-Haz-Asb-HIC

Mr. Amir Gholami
Alameda County Health Care Services Agency
Department of Environmental Health
Environmental Protection Division
1131 Harbor Bay Parkway, Room 250
Alameda, CA 94502-6577

208294

Alameda County
FEB 05 2004
Environmental Health

Re: WORKPLAN TRANSMITTAL
23rd Avenue Partners
1125 Miller Avenue
Oakland, California

Dear Mr. Gholami:

Environmental Bio-Systems, Inc. (EBS) is pleased to submit this workplan and attached permit for the above mentioned site. EBS has also submitted copies of the Workplan to the client and will forward the files to Underground Storage Tank Cleanup Fund (USTCF). Once approved, we will perform the work described in the workplan.

I will be teaching Environmental Engineering on a Fulbright grant in Jamaica from February 14 to March 20, 2004. If you would like to move this project forward before I return, then please contact Matthew Bromley, R.G. of Clearwater Group (510) 307-9943; ext. 231 who has been briefed about the project. He can move the project forward during my absence.

I will be available by email (augerpro@sbcglobal.net), even in Jamaica.

Sincerely,

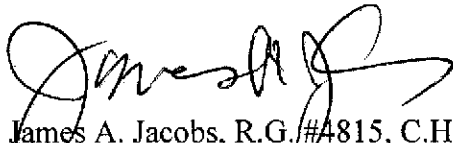

James A. Jacobs, R.G.#4815, C.H.G.#88
Chief Hydrogeologist

Cc: Mr. Al Pelton
23rd Avenue Partners
P.O. Box 7509
Oakland, CA 94601



Environmental Bio-Systems, Inc.

Innovative Solutions for a Better Environment

www.EBSinfo.com Since 1989

Contractor's Lic. # 687236: A-B-C57-Haz-Asb-HIC

Alameda County
FEB 05 2004
Environmental Health

WORK PLAN:
GROUND WATER MONITORING
WELL INSTALLATION
Project #707

1125 Miller Avenue
Oakland, California

PREPARED BY ENVIRONMENTAL BIO-SYSTEMS, INC.

FOR

MR. AL PELTON

23RD AVENUE PARTNERS

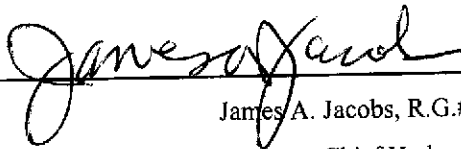
James A. Jacobs, R.G.#4815, C.H.G.
Chief Hydrogeologist

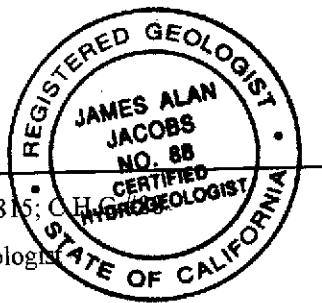

26 January 2004

TABLE OF CONTENTS

1. INTRODUCTION.....	1
2. SITE DESCRIPTION	2
2.1. Location	2
2.2 Topography, Geology and Hydrology.....	2
3. PREVIOUS ENVIRONMENTAL WORK	5
4. SCOPE OF WORK.....	8
4.1. Drilling.....	8
4.1.1. Soil Sampling.....	8
4.1.2. Drill Cuttings	9
4.2. Well Installation.....	9
4.2.1. Well Locations	9
4.2.2. Well Construction	10
4.2.3. Well Development	10
4.2.4. Well Sampling	10
4.2.5. Purge and Decontamination Water	11
4.3. Sample Analyses	12
4.4. Decontamination Procedures	12
4.5. Well Casing Survey	12
5. DOCUMENTATION.....	13
6. CONDITIONS	14
7. REFERENCES	16
8. DISTRIBUTION.....	18

APPENDICES

APPENDIX A. FIGURES

FIGURE 1. SITE LOCATION MAP

FIGURE 2. SITE MAP

FIGURE 3. WELL CONSTRUCTION DIAGRAM

APPENDIX B. REGULATORY CORRESPONDENCE

1. INTRODUCTION

Environmental Bio-Systems, Inc. (EBS) has been retained by Mr. Al Pelton of the 23rd Avenue Partners (the client) to prepare and carry out this work plan for subsurface exploration and ground water monitoring well installation at 1125 Miller Avenue in Oakland, California (the site). A site location map and site map are included as Figures 1 and 2 of Appendix A.

This work plan has been prepared pursuant to a request by the Alameda County Health Care Services Agency (ACHCSA). The proposed scope of work is intended to assess the lateral impact by petroleum hydrocarbons to soil and ground water at the site. The existence of this release was discovered beneath the fuel dispensers during the previous removal of two underground storage tanks (USTs) at the site.

The site is owned by the Client. The principal project contacts are:

Client - Client: Mr. Al Pelton, 23rd Avenue Partners, P.O. Box 7509, Oakland, CA 94601

Consultant – Mr. James A. Jacobs, C.H.G. #88, Chief Hydrogeologist, Environmental Bio-Systems, Inc., 707 View Point Road, Mill Valley, CA 94941; tel: 415-381-5195

2. SITE DESCRIPTION

2.1. Location

The Site is located at 1125 Miller Avenue in Oakland, California. The Site contains a single two-story building currently housing live-work apartments and studio space. It is located in the City of Oakland, County of Alameda, and California. The United States Geological Survey Oakland East Quadrangle Map shows the site to be located in Section six, Township two south, Range three west of the Mount Diablo Base and Meridian (U.S.G.S., 1980). Site Location Map and Site Map, Figures 1 and 2, respectively, are included in Appendix A.

Miller Avenue bounds the Site from the southwest to north. Another apartment building lies across Miller Place to the northeast. A fenced parking and storage lot abuts the southeast end of the building. A set of railroad tracks lies behind a chain-link fence to the northeast of the Subject Property.

A reconnaissance of properties within a one-quarter mile property radius was conducted to visually identify nearby sites that might have regulatory information and files. The area contains mixed residential and industrial units along Miller Avenue, East 23rd Avenue, and East 11th Street.

2.2 Topography, Geology and Hydrology

Topography

Based on the USGS East Oakland 7.5 minute topographic quadrangle map (1949), the local topography is relatively flat, with a slight topographic gradient of approximately one percent to the southwest toward the Alameda Tidal Canal.

The elevation of the Subject Property is approximately 18 feet above mean sea level.

Regional Geology

The Site is located Within the Coast Ranges Province of California. This province is bounded on the north by the Oregon State line, on the east by the South Fork Mountain and Coast Range trusts bordering the Klamath Mountains and Great Valley Provinces, on the south by the Santa Ynez Fault and Transverse Ranges Province, and on the west by the continental borderland. San Francisco Bay fills a late Pliocene structural depression that divides the regionally southeast-northwest trending Coast Ranges province into northern and southern portions. Extensive folding and faulting during the late Pliocene to mid-Pleistocene Epochs created northwest trending ranges within this province (Norris and Webb, 1976). The deeper Jurassic Franciscan Formation meta-sediments, found east of the San Andreas Fault, consists of fractured greywacke, serpentine, shales, cherts, limestones and conglomerates making up the core of the California Coast Range. The Franciscan represents a subduction zone complex. The area in which the Site is located has been geologically mapped as Quaternary (Holocene) estuarine deposits (Bay Mud, Qhbm). The Hayward Fault Zone is mapped approximately 3.5 miles east of the Site. The faults and soil characterizations of the area were reviewed on the Geological Map of California prepared by the California Geological Survey, (Jennings, 1969).

Site Geology

Soils encountered during EBS drilling of October, 2000 (EBS, 2001) typically included medium-grained dense sand to approximately two feet below ground surface (bgs), at which depth medium-stiff silty clay was encountered. The clay become very stiff at approximately four feet bgs, continuing to approximately 16

feet bgs, at which depth clayey silty sand was encountered to the total drilled depth (22 feet bgs). Groundwater was first encountered at between 16.5 and 17 feet bgs. Groundwater flow direction on the Subject Property is estimated to be flowing to the south and west toward the Alameda Tidal Canal and ultimately into San Francisco Bay. The Alameda Tidal Canal, located between the Oakland Harbor and the San Leandro Bay, is a little more than ¼ mile south and southwest of the Subject Property.

3. PREVIOUS ENVIRONMENTAL WORK

December 1998

EBS excavated and removed two 5,000-gallon diesel USTs and associated product piping from the site. Two soil samples were collected near the ends of each tank (a total of four samples) from approximately nine feet below ground surface (bgs). All four soil samples were subsequently analyzed for total petroleum hydrocarbons calculated as diesel (TPHd), benzene, toluene, ethylbenzene and total xylenes (BTEX), and methyl tertiary butyl ether (MtBE). Sample locations adjacent to the ends of Tank A were both taken from the south pit wall due to access limitations. Of the two samples taken from the ends of this tank, the east end sample was found to contain 1,800 milligrams per kilogram (mg/kg) TPHd and 0.051 mg/kg xylenes. The west end sample from this tank was not found to contain detectable concentrations of any of the chosen analytes. Samples collected from the soil adjacent to the ends of Tank B (north and west pit walls) were not found to contain any of the chosen analytes.

October 2000

In October 2000, EBS drilled four soil cores (designated TW1, TW2, TW3 and D1). Soil cores TW1 through TW3 were drilled in the concrete-paved area surrounding the former UST excavation. Core D1 was drilled adjacent to the former dispenser location. The dispenser had been housed within an enclosed room at the north end of the building. EBS collected four soil samples from the cores and installed pre-packed temporary well points in two of the cores (TW2 and TW3). The sampling was performed by FAST-TEK Engineering Support Services of Point Richmond, California (C-57 Lic. #624461) using a Geoprobe 5400 direct push rig. The borings TW2 and TW3 were drilled to a total depth of 22 feet bgs. Boring D1 was drilled to a total depth of 8 feet bgs, and core TW1

was abandoned at 3 feet bgs due to subsurface obstructions without soil or groundwater sampling. Groundwater was encountered between 16.5 feet and 17.0 feet below ground surface (bgs).

EBS submitted four soil samples and two groundwater samples to Analytical Sciences, Inc. of Petaluma, California, California State certified laboratory for the following analyses: Total petroleum hydrocarbons as diesel (TPHd) benzene, toluene, ethyl benzene and total xylenes (BTEX), methyl t-butyl ether (MTBE).

Analytical Results Soil sample TW2-16.5' was found to contain 4,200 mg/kg TPHd and 1.4 mg/kg benzene. Soil sample TW3-17' was found to contain 2,700 mg/kg TPHd. Soil samples D1-3' and D1-8' were found to contain 3,400 and 34 mg/kg TPHd, respectively. Groundwater sample TW2-H₂O was found to contain 660 µg/L TPHd, 65 µg/L benzene, 2.4 µg/L, toluene, and 3.2 µg/L total xylenes. Groundwater sample TW3-H₂O was found to contain 800 µg/L TPHd and 0.9 µg/L benzene. The results were presented in an EBS Subsurface Exploration Report dated December 31, 2001.

October, 2001

EBS drilled four exploratory soil cores at the Site. One of the cores was abandoned without sampling due to an impenetrable obstruction. Groundwater was encountered in two of the borings at 16.5 and 17 feet bgs. Screening of soil samples using an OVM yielded no detectable ionizable compounds. Four soil samples were submitted for laboratory analysis to detect TPHd, BTEX, and MtBE. Temporary wells were constructed of pre-packed well screen within two of the soil cores. Groundwater samples were collected from both temporary wells and submitted for laboratory analysis to detect TPHd, BTEX, and MTBE.

Soil samples were found to contain TPHd at concentrations up to 4,200 mg/kg, and benzene up to 1.4 mg/kg. Groundwater samples were found to contain TPHd at concentrations up to 800 µg/L, benzene up to 65 µg/L, toluene up to 2.4 µg/L, and total xylenes up to 3.2 µg/L.

Subsurface conduits at the Site include relatively shallow utility trenches (i.e. gas, water and sewer). The nearest observed trench supplies a fire hydrant located approximately 12 feet northwest of TW3. According to the utility survey conducted during this project, the supply line for this hydrant approaches from the northwest (the supply line does not extend beneath the Site). Gas and sewer lines were not observed in proximity to the former UST excavation.

According to the EBS well survey dated 26 July 1993, groundwater flow direction at a nearby site (527 23rd Avenue) is to the north with a gradient of approximately 0.01 feet per foot. An Alameda County Public Works Agency survey of groundwater wells showed no water supply wells or other active wells in the nearby vicinity. The nearest sensitive receptors are present in residential dwellings on the Site and on an adjacent property immediately to the east of the Site.

A Risk Management Plan (RMP) was prepared by EBS on September 11, 2002 and should be used to prevent exposure to subsurface contaminants to workers or residents. The concrete surface inside the building should be maintained and sealed to minimize any potential for upward migration of contaminants. Written documentation of this activity should be performed. The RMP also stipulates that no wells (domestic or irrigation) can be installed on the Subject Property. A Site Closure Report was prepared by EBS on October 3, 2002.

4. SCOPE OF WORK

The scope of work contained within this work plan is intended to meet the requirements of the ACHCSA letter of request (Appendix B). The scope of work is to evaluate the extent of ground water impact by MTBE and near the former site UST and dispenser locations. Three soil borings will be drilled and completed as ground water monitoring wells (to be designated MW1 to MW3). Figure 2 shows the prospective locations of the wells. The elevations of these wells will be measured by a licensed surveyor and the direction and gradient of ground water flow will subsequently be calculated. The new wells will also be surveyed with a global positioning system (GPS) for the state's Geotracker system. All work will be performed under the supervision of a California Registered Geologist.

4.1. Drilling

Three soil borings (to be designated MW1 to MW3) will be drilled using hollow stem augers advanced by a truck mounted drill rig. The borings will be drilled at the locations depicted on Figure 2.

4.1.1. Soil Sampling

Soil samples will be collected from the borings using a California split-spoon sampler holding three stainless steel tubes. Upon removal from the sampler, the bottom ends of the tubes will be sealed with Teflon sheets and tight fitting caps. Each tube will be labeled with a unique designation for this project and stored in an insulated cooler on top of ice. A chain of custody will be generated in the field and will accompany all samples during transit to the laboratory.

A thermometer will be placed into the cooler with the samples. The laboratory representative receiving the samples will be asked to read the temperature inside the cooler, and to record it on the sample chain of custody.

At least one soil sample will be submitted for laboratory analyses from each borehole from just above the soil/ground water interface. Ground water is anticipated to be encountered at approximately 15 to 20 feet below ground surface (bgs). Additional soil samples from other horizons may be submitted if field observations (e.g. elevated PID readings, soil discoloration) indicate the possibility of petroleum hydrocarbon impact.

4.1.2. Drill Cuttings

All soil cuttings generated during drilling will be contained within Department of Transportation (DOT) approved 55-gallon drums. Subsequent to profiling, the drums of soil will be transported and disposed/recycled at an approved facility.

4.2. Well Installation

4.2.1. Well Locations

MW1 will be drilled outside the rollup door, about 5 feet south of the former tank pit and 5 feet north of the former dispenser. Monitoring well MW2 will be drilled about 5 feet south of TW2, in the presumed downgradient direction to find the downgradient zero contamination line. MW3 will be drilled approximately 30 feet north of MW1. MW3 is designed to test the cross gradient zero contamination line.

4.2.2. Well Construction

Wells MW1 to MW3 will be constructed of 2 inch diameter PVC screen and casing. The methods of construction used will be in accordance with the standards and guidelines of the ACHCSA and the California Department of Water Resources. A well construction diagram is included as Figure 3 in Appendix A

The wells will be installed after advancing the augers to a depth of approximately 10 feet below first water encounter. The screened interval of the wells will be extended to approximately 2 feet above the depth at which water is encountered within the borings. Completion of the wells will include a filter pack of #2/12 or #3 sand to a depth of 0.5 to 1 foot above the tops of the screens, 0.5 foot bentonite clay spacer, 2 feet of Portland cement seal to grade, traffic boxes set in concrete, and locking well caps with a water-tight seals.

4.2.3. Well Development

Wells MW1 to MW3 will be developed after allowing at least 72 hours to elapse following completion of the ground water monitoring well installation. Development of the wells will be performed using alternate surging and bailing. The wells will be purged until free of sediment or until measured parameters of pH, temperature, and conductivity have been noted to have stabilized.

4.2.4. Well Sampling

Sampling of all three wells will be performed subsequent to allowing a period of at least 48 hours (since installing MW1 to MW3) for stabilization following

development. A field log will be maintained by the sampling technician during purging and sampling. Observations of the presence or absence and/or thickness of free or emulsified product as well as the presence of sheen will be included on the sampling log. Other pertinent information including well recharge rates, pH, temperature, conductivity, and physical conditions at the time of sampling will also be recorded.

A minimum of 4 casing volumes will be purged from the new wells prior to collection of samples. When periodic measurements of pH, temperature, and conductivity are found to have stabilized, a water sample will be collected from the well using a new disposable bailer. No sample will be collected for laboratory analysis from wells exhibiting measurable free product.

Of the new wells which fail to recharge sufficiently prior to the purging of at least 4 well casing volumes will be allowed to recovered to 80% of their initial water level prior to sampling.

4.2.5. Purge and Decontamination Water

All purge and decontamination water generated during this project will be contained within Department of Transportation (DOT) approved 55-gallon drums. The drums will be labeled and stored on-site in the location depicted on Figure 2. Subsequent to profiling, the drums will be transported and disposed or recycled at an approved facility.

4.3. Sample Analyses

All soil and ground water samples will be analyzed by Kiff Analytical of Davis, California. Kiff is certified by the California environmental laboratory accreditation program (ELAP). All samples submitted for laboratory analysis will be analyzed for the following:

- Total petroleum hydrocarbons as diesel (TPHd) using the Environmental Protection Agency (EPA) Method 8015.
- Benzene, toluene, ethylbenzene, and total xylenes (BTEX) using the EPA Method 8260.

Although analyzed in the past, since MTBE was not found on site, nor is it associated with diesel fuel, MTBE is not recommended for analyses.

4.4. Decontamination Procedures

All downhole drilling and sampling equipment will be cleaned using an Alconox solution, tap water rinse, and deionized water rinse prior to the drilling of each boring. All decontamination water will be stored on-site in labeled drums approved by the Department of Transportation (DOT) for this purpose.

4.5. Well Casing Survey

The top of well casing (TOC) of the three site wells will be surveyed to Mean Sea Level. Ground water elevations within the wells will then be calculated, and a ground water flow direction and gradient map will be generated for inclusion in the final report.

5. DOCUMENTATION

A final report documenting the observations, results, conclusions, and recommendations will be prepared and submitted upon completion of field work. The report will include scaled diagrams, laboratory analytical reports, and chain of custody documentation. As part of the report, EBS will determine a cleanup priority classification for the site.

Based on the results of the proposed scope of work and discussions with the ACHCSA at the time of report submittal, EBS will evaluate future activities. If required by the ACHCSA, EBS will develop a Corrective Action Plan (CAP) to address cleanup levels. The objective of the various investigation and remedial activities is to move the facility to a site closure and no further action status.

6. CONDITIONS

EBS will perform the stated scope of work in accordance with generally accepted standards of current environmental practice in Northern California. Conclusions and recommendations presented by EBS are time-dependent and should not be considered valid after a 1 year period from issue of the summary report. After 1 year from the issue of this report, site conditions and recommendations contained within the report should be reviewed.

The proposed study will be performed solely for the purpose of evaluating environmental conditions of the site subsurface relative to hydrocarbon impact. No engineering or geotechnical references will be implied or should be inferred.

Evaluation of the condition of the site, for the purpose of the proposed study, will be made from a limited number of observation points. Subsurface conditions may deviate away from these points. Additional work, including further study of the subsurface, can reduce the inherent uncertainties associated with this type of work.

The proposed study will be performed, and the report would be prepared for the sole use of our Client, Mr. Al Pelton of 23rd Avenue Partners. The report and the findings contained therein shall not be disclosed to nor used by any other party without the prior written consent of Environmental Bio-Systems, Inc.

Recommendations stated in the proposed summary report will represent professional opinions that our firm has endeavored to provide with competence and reasonable care. We are not able to eliminate the risks associated with

environmental work. No guarantees or warrants, express or implied, are provided regarding our recommendations.

Any and all hazardous wastes generated during this work are to remain the property of the Client to be disposed of properly. It is the clients' responsibility to identify property lines and easements. EBS is not responsible for the accuracy of any property line, easement, or other marker identified by the client. EBS will contact Underground Service Alert (USA), a public utilities locating service which is provided by the utility companies. USA will mark the location of utilities on public property. EBS will not be liable for any damages to underground structures as a result of subsurface activities.

7. REFERENCES

City of Oakland, 2002, City Water Maps, Public Works Department, City of Oakland, California

Earth Systems Environmental, Inc., July 26, 1993, Letter Report, Soil and Groundwater Investigation.

Environmental Data Resources, April 29, 2002, The EDR Radius Map with GeoCheck; Topographic Maps, Sanborn Insurance Maps, Historic Aerial Photographs; 23rd Avenue Partners, 1125 Miller Ave., Oakland, CA 94617; Inquiry Number: 770535.3S, Southport, Connecticut.

Environmental Bio-Systems, Inc., October 3, 2002, Site Closure Report, 23rd Avenue Partners, 1125 Miller Avenue, Oakland, California; Mill Valley, California

Environmental Bio-Systems, Inc., December 31, 2001, Subsurface Exploration, Project #079-541A, 23rd Avenue Partners, 1125 Miller Avenue, Oakland, California; San Jose, California

Environmental Bio-Systems, Inc., March, 2000, Site Closure Workplan, Project #590, 23rd Avenue Partners, 1125 Miller Avenue, Oakland, California; Mill Valley, California

Environmental Bio-Systems, Inc., February 18, 2000, Workplan: Subsurface Exploration, Project #079-541B, 23rd Avenue Partners, 1125 Miller Avenue, Oakland, California; San Jose, California

Environmental Bio-Systems, Inc., April 21, 1999, UST Excavation, 23rd Avenue Partners, 1125 Miller Avenue, Oakland, California; San Jose, California

Norris, Robert M., and Webb, Robert W., Geology of California, John Wiley & Sons, 1976.

State Water Resources Control Board (SWRCB) August, 2000, Application of Risk-Based Screening Levels and Decision Making to Sites with Impacted Soil And Groundwater (Interim Final) San Francisco Region, (Region 2).

United States Geological Survey (USGS), 1959, photorevised, 1980, Oakland East, California Quadrangle Map, 7.5 Minute Series, Topographic Map, Washington, D.C.

8. DISTRIBUTION

Environmental Bio-Systems, Inc. has submitted copies of this document to the following agencies on behalf of the client.

CLIENT

Mr. Al Pelton
23rd Avenue Partners
P.O. Box 7509
Oakland, CA 94601

ACHCSA CONTACT:

Mr. Amir Gholami
Alameda County Health Care Services Agency
Department of Environmental Health
Environmental Protection Division
1131 Harbor Bay Parkway, Room 250
Alameda, CA 94502-6577

REGIONAL BOARD CONTACT

1-22-04; Not required to submit any report to RWQCB:
California Regional Water Quality Control Board
San Francisco Bay Region
1515 Clay Street, Suite 1400
Oakland, CA 94612

26 January 2004

23rd Avenue Partners
1125 Miller Avenue
Oakland, California

Page 19

APPENDIX A:

FIGURES

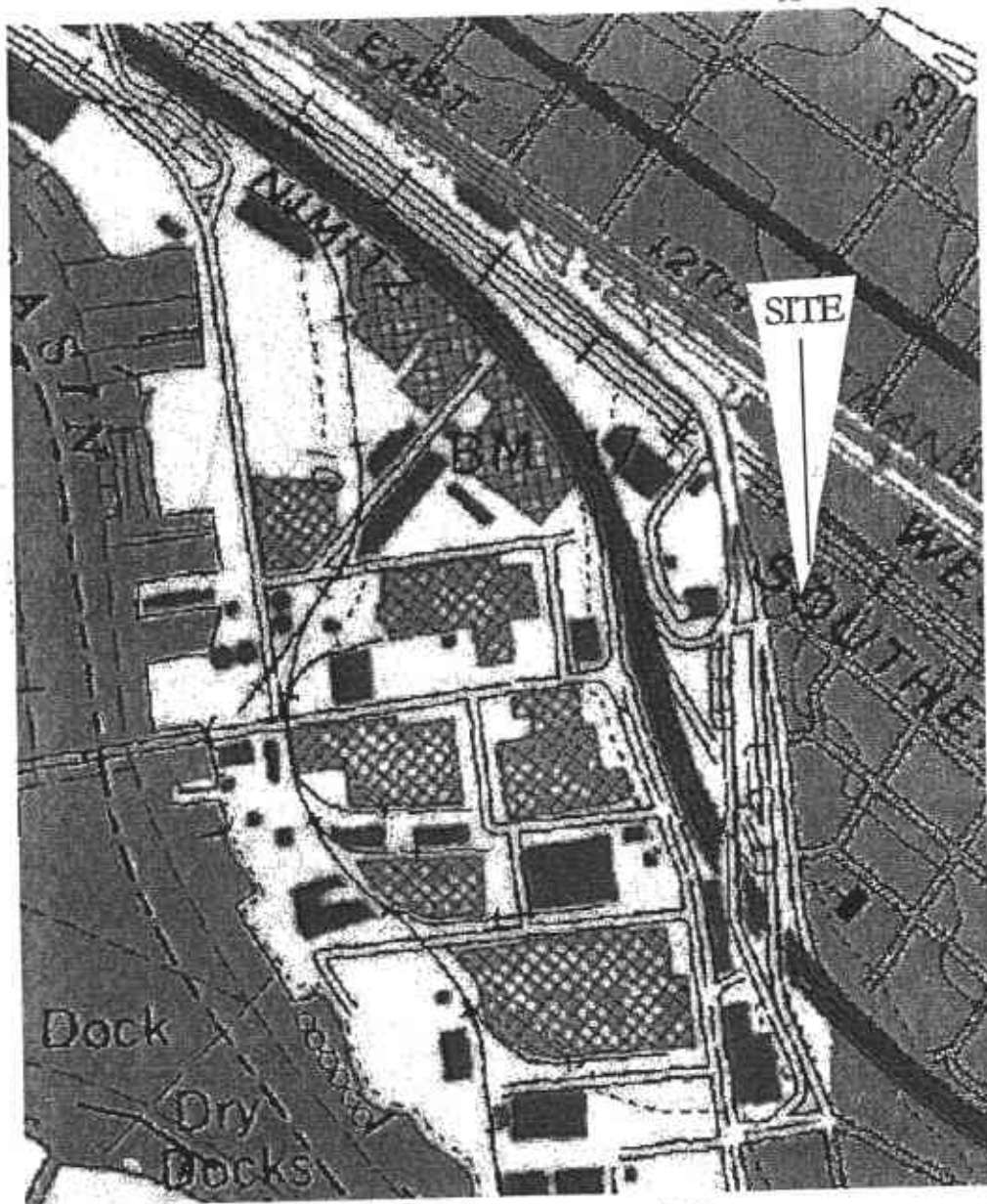

0 200M



Project #: 707

Date Drawn: January 22, 2004

Drawn By: JAJ

Scale: 1 inch = 200 M

**FIGURE 1:
SITE LOCATION MAP**

23rd Avenue Partners
1125 Miller Ave.
Oakland, CA

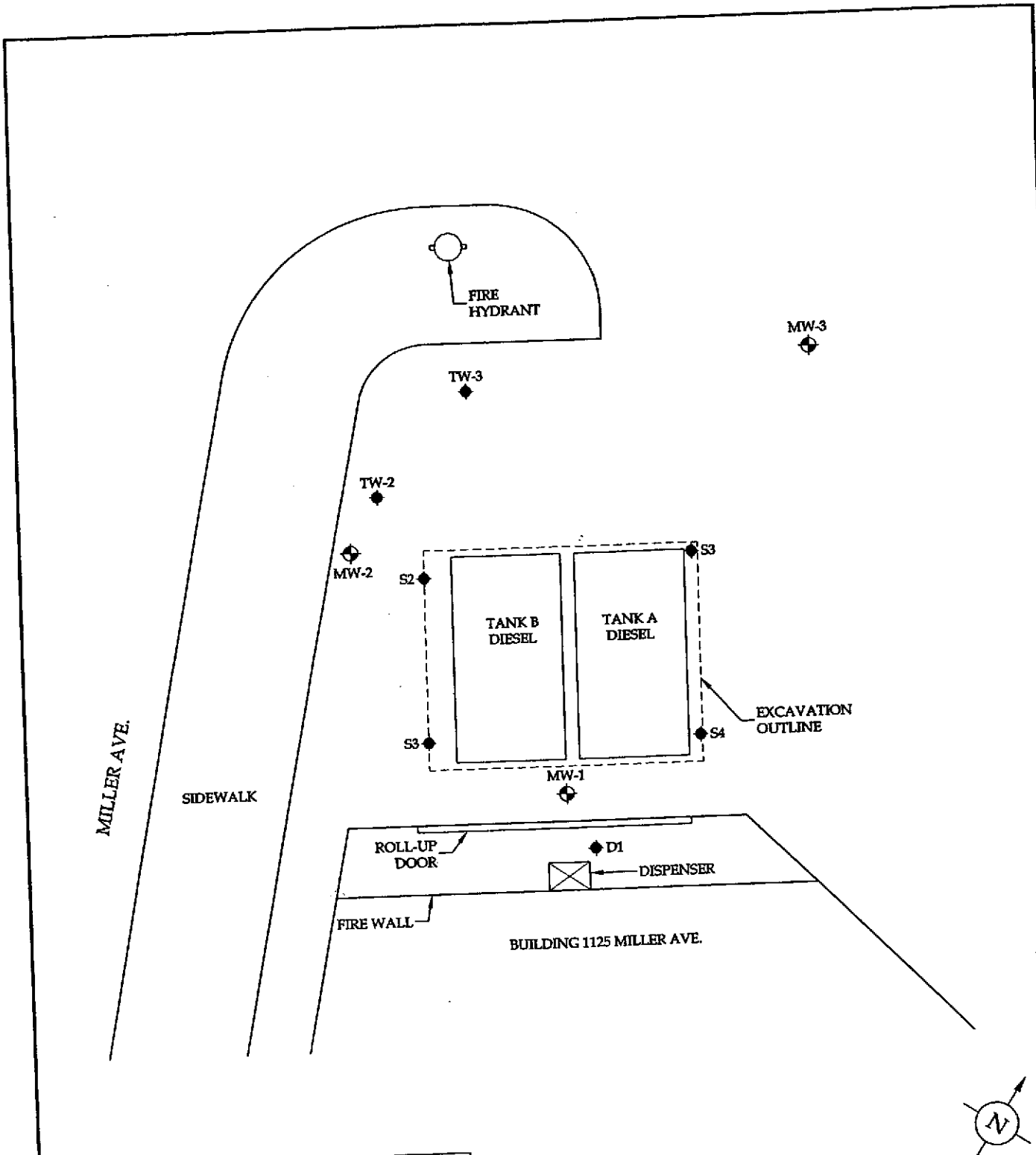

LEGEND	
	MW-1 MONITORING WELL LOCATION (PROPOSED)
	SOIL SAMPLE

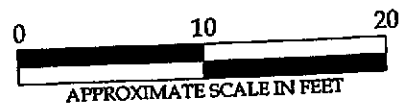

	ENVIRONMENTAL BIO-SYSTEMS INC.			SITE PLAN 23rd Avenue Partners 1125 Miller Avenue Oakland, California
	Project No. 707	Figure Date 1/04	Figure 2	

FIG. 3 - MONITORING WELL INSTALLATION DIAGRAM

Date	1/22/04	Total Depth	25'	Casing type	Sch 40 PVC
Client	23 rd Ave. Part	Screen from/to	15-25'	Blank ft.	2-in dia.; 5'
Well No.	MW1-3	Filter Pack	14-25'	Screen ft.	2-in dia; 10'
Permit No.		Bentonite	13.5-14'	Slot size	0.010"
Storage soil	55 gal drums	Grout	Portland II	Bags cement	2 per well
Consultant	EBS	Drill Rig Type	HSA	Bentonite	0.5'
Driller	FAST-TEK	Auger ID/OD	4.25"; 7.63"	Bags sand	6 per well
Geologist	J. Jacobs	Sampler	CA split spn	Filter pack	2/12 sand
Screening	PID	Completion	Flush mount	Development	Surge block

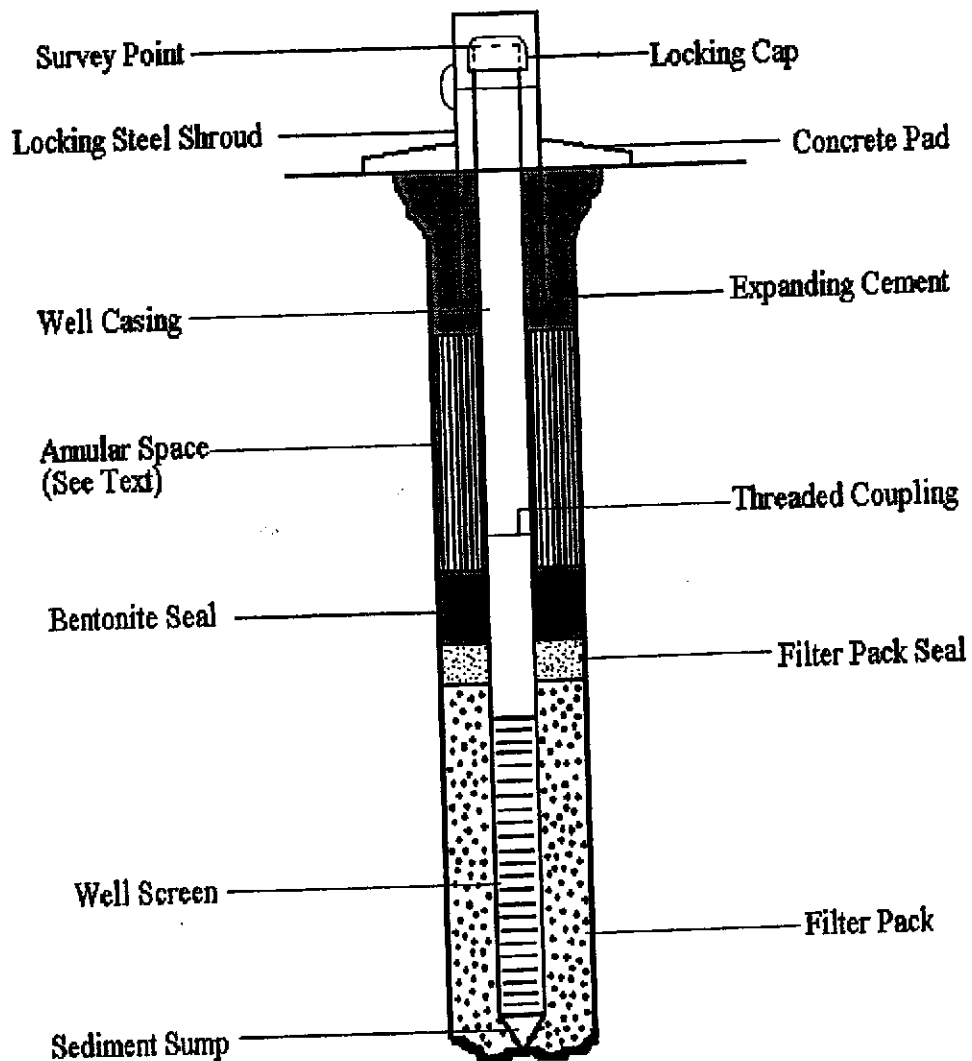

26 January 2004

23rd Avenue Partners
1125 Miller Avenue
Oakland, California

Page 20

APPENDIX B:

REGULATORY CORRESPONDENCE

RO0000294

September 10, 2003

Mr. Allen Pelton
23rd Avenue Partners
P.O. Box 7509
Oakland, CA 94601

RE: 1125 Miller Avenue, Oakland, CA

Dear Mr. Pelton:

Alameda County Environmental Health (ACEH) staff has reviewed Environmental Bio-Systems, Inc's October 2002 *Site Closure Report* and your request for closure of the above referenced site. Based upon our review of your site we are unable to close your case at this time. Additional work is necessary at your site to progress toward case closure. We request that you address the following technical comments below.

TECHNICAL COMMENTS

- The horizontal and vertical extent of soil and groundwater contamination has not been delineated.

Additionally, please be advised that this decision is subject to appeal to the State Water Resources Control Board (SWRCB), pursuant to Sections 25296.40, 25297.1, and 25299.39.2 of the California Health & Safety Code. Please contact the SWRCB Underground Storage Tank Program at (916) 341-5851 for information regarding the appeal process. Petitions must be filed within 30 days from the date of this letter.

Lastly, since I am no longer working in the LOP program, your case has been assigned to Mr. Amir Gholami. He can be reached at (510) 567-6876

eva chu
Hazardous Materials Specialist

c: Donna Drogos
Amir Gholami

email: James Jacobs

1125miller-5

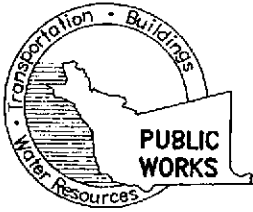

ALAMEDA COUNTY PUBLIC WORKS AGENCY

WATER RESOURCES SECTION

399 ELMHURST ST. HAYWARD CA. 94544-1395

PHONE (510) 670-6633 James Yoo

FAX (510) 782-1939

APPLICANTS: PLEASE ATTACH A SITE MAP FOR ALL DRILLING PERMIT APPLICATIONS
DESTRUCTION OF WELLS OVER 45 FEET REQUIRES A SEPARATE PERMIT APPLICATION

ALAMEDA COUNTY
FEB 05 2004
ENVIRONMENTAL SERVICES

DRILLING PERMIT APPLICATION

FOR APPLICANT TO COMPLETE

LOCATION OF PROJECT 1125 Miller Ave
Oakland CA

CLIENT Name 23rd Ave Partners
Address P.O. Box 7509 Phone 510-533-6600
City Oakland CA Zip 94601

APPLICANT Name Environmental Bio-Systems, Inc
Address 707 Viewport Rd Phone 415-381-5195
City Mill Valley CA Zip 94941

TYPE OF PROJECT
Well Construction Geotechnical Investigation
Cathodic Protection General
Water Supply Contamination
Monitoring Well Destruction

PROPOSED WATER SUPPLY WELL USE
New Domestic Replacement Domestic
Municipal Irrigation
Industrial Other environmental study

DRILLING METHOD:
Mud Rotary Air Rotary Auger
Cable Other

DRILLER'S NAME FAST-TEK Engineering Support Svcs.

DRILLER'S LICENSE NO. 624461 C-57

WELL PROJECTS
Drill Hole Diameter 8 in. Maximum
Casing Diameter 2 in. Depth 25 ft.
Surface Seal Depth 10 ft. Owner's Well Number MW-1 to MW-3

GEOTECHNICAL PROJECTS
Number of Borings _____ Maximum
Hole Diameter _____ in. Depth _____ ft.

STARTING DATE When approved
COMPLETION DATE 30 days - 90 days

I hereby agree to comply with all requirements of this permit and Alameda County Ordinance No. 73-68.

APPLICANT'S SIGNATURE [Signature] DATE 1-29-04

PLEASE PRINT NAME James A Jacobs CHG #88 Rev. 9-18-02

FOR OFFICE USE

PERMIT NUMBER _____
WELL NUMBER _____
APN _____

PERMIT CONDITIONS

Circled Permit Requirements Apply

A. GENERAL

1. A permit application should be submitted so as to arrive at the ACPWA office five days prior to proposed starting date.
2. Submit to ACPWA within 60 days after completion of permitted original Department of Water Resources-Well Completion Report.
3. Permit is void if project not begun within 90 days of approval date

B. WATER SUPPLY WELLS

1. Minimum surface seal thickness is two inches of cement grout placed by tremie.
2. Minimum seal depth is 50 feet for municipal and industrial wells or 20 feet for domestic and irrigation wells unless a lesser depth is specially approved.

C. GROUNDWATER MONITORING WELLS INCLUDING PIEZOMETERS

1. Minimum surface seal thickness is two inches of cement grout placed by tremie.
2. Minimum seal depth for monitoring wells is the maximum depth practicable or 20 feet.

D. GEOTECHNICAL

Backfill bore hole by tremie with cement grout or cement grout/sand mixture. Upper two-three feet replaced in kind or with compacted cuttings.

E. CATHODIC

Fill hole anode zone with concrete placed by tremie.

F. WELL DESTRUCTION

Send a map of work site. A separate permit is required for wells deeper than 45 feet.

G. SPECIAL CONDITIONS

NOTE: One application must be submitted for each well or well destruction. Multiple borings on one application are acceptable for geotechnical and contamination investigations

APPROVED _____

DATE _____

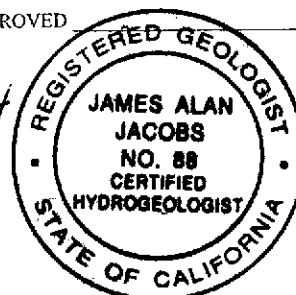

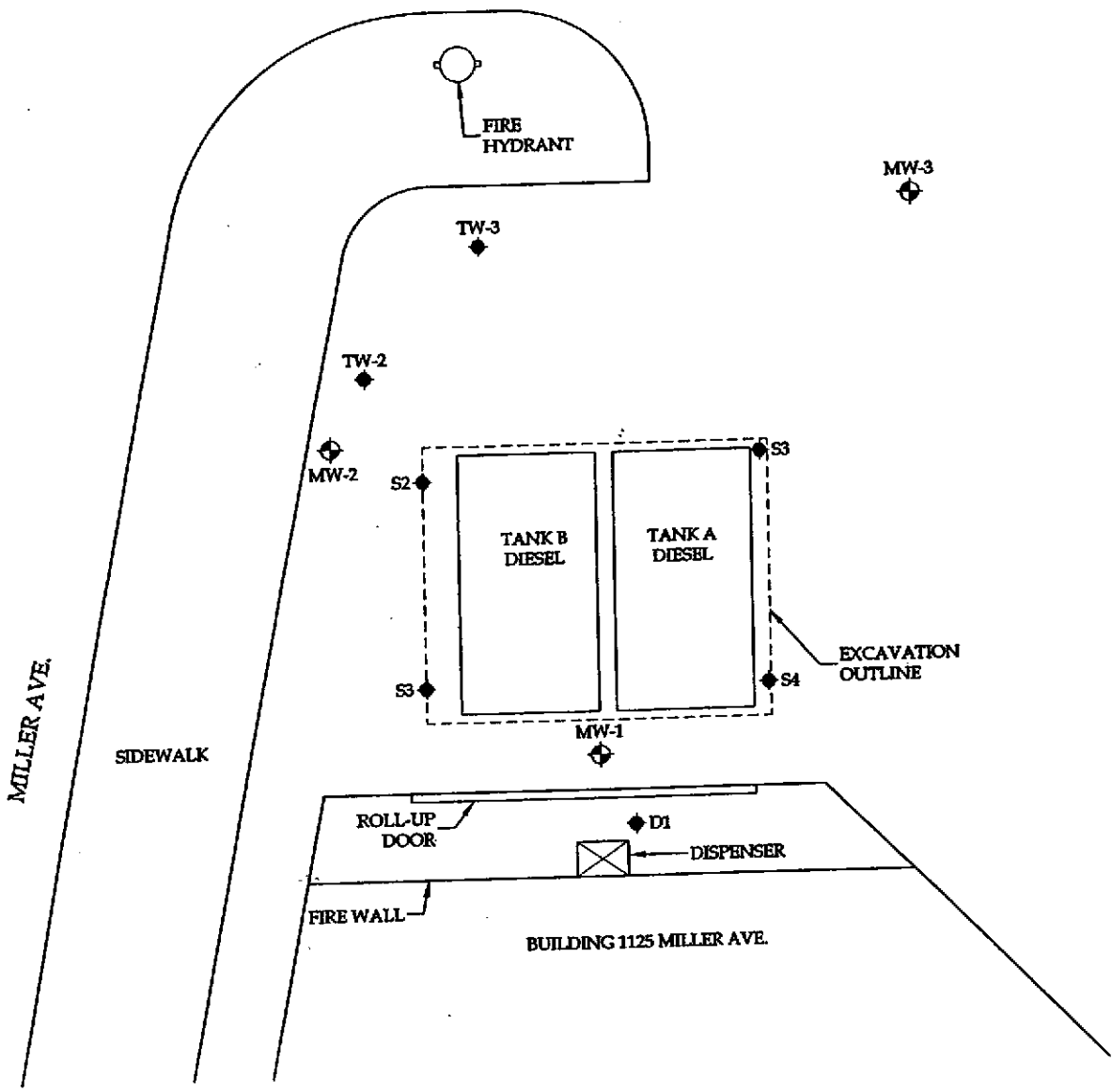

LEGEND	
	MW-1 MONITORING WELL LOCATION (PROPOSED)
	SOIL SAMPLE

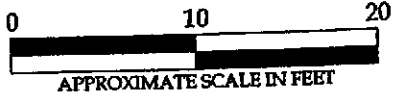

	ENVIRONMENTAL BIO-SYSTEMS INC.			SITE PLAN 23rd Avenue Partners 1125 Miller Avenue Oakland, California
	Project No. 707	Figure Date 1/04	Figure 2	

FIG. 3 - MONITORING WELL INSTALLATION DIAGRAM

Date	1/22/04	Total Depth	25'	Casing type	Sch 40 PVC
Client	23 rd Ave. Part	Screen from/to	15-25'	Blank ft.	2-in dia.; 5'
Well No.	MW1-3	Filter Pack	14-25'	Screen ft.	2-in dia; 10'
Permit No.		Bentonite	13.5-14'	Slot size	0.010"
Storage soil	55 gal drums	Grout	Portland II	Bags cement	2 per well
Consultant	EBS	Drill Rig Type	HSA	Bentonite	0.5'
Driller	FAST-TEK	Auger ID/OD	4.25"; 7.63"	Bags sand	6 per well
Geologist	J. Jacobs	Sampler	CA split spn	Filter pack	2/12 sand
Screening	PID	Completion	Flush mount	Development	Surge block

