

ALCO
HAZMAT
94 JUL 21 11:01

STD 3/60 7/27/94
Shked to Chris Brown

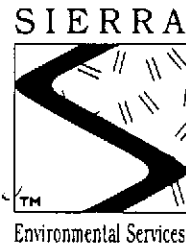

July 19, 1994

John Legallet
Telegraph Business Properties
1401 Griffith Street
San Francisco, CA 94124

* need to analyze for
D C solvents for SWells
permit process
workplan

Re: Interim Ground Water Remediation System
Telegraph Business Park
5427 Telegraph Avenue
Oakland, California
SES Project #4-719-09

Dear Mr. Legallet:

As requested, Sierra Environmental Services (SES) has prepared this work plan for the installation and operation of an interim ground water remediation system at the above-referenced site (Figure 1, Appendix A).

BACKGROUND

Site History

The site was formerly a large-scale dry-cleaning establishment. Seventeen former underground storage tanks were used by previous occupants to store stoddard solvent, stoddard solvent waste, boiler fuel and vehicle fuel.

In May, 1992, SES supervised the removal of 17 underground storage tanks from the property. Hydrocarbons as gasoline, diesel, stoddard solvent, benzene, toluene, ethylbenzene, and xylenes were detected in sidewall samples collected from the tank excavations. An account of this work was detailed in the July, 1992 SES report.¹

¹ Sierra Environmental Services, 1992, Consultant's Report of Tank Removal Activities, prepared for Telegraph Business Properties, July 21, 1992, 9 pages and 4 appendices.



John Legallet
July 19, 1994
SES Project #4-719-09

Page 2

Previous Investigations

On December 13 and 14, 1993, SES installed three ground water monitoring wells on-site. An account of this work was detailed in the April, 1994 SES report.²

SES has been performing quarterly monitoring and monthly water level measurements for this site since January, 1994. The April 6, 1994 ground water monitoring event indicated that the static water level at the site was approximately six to ten feet below grade. The ground water flow direction beneath the site was toward the west at a gradient of 0.028 feet/feet.³ Historic analytic results for ground water are summarized in Tables 1 and 2 (Appendix B).

Topographic and Geologic Setting

The site is located in the City of Oakland, Alameda County, California. The topography of the site is relatively flat. The ground water flow direction is typically toward the west-southwest. The closest surface water is Glenn Echo Creek, which is located approximately one half mile southeast of the site and which flows into Lake Merritt. The elevation of the site is approximately one hundred fifteen feet above mean sea level.

The site is underlain by Late Pleistocene Alluvium, which consists of weakly consolidated, slightly weathered, poorly sorted, irregular interbedded clay, silt, sand, and gravel.⁴ Previous subsurface investigations indicated that the subsurface sediments consist of a very low permeability clayey sand unit from ground surface to approximately seven feet below ground

² Sierra Environmental Services, 1994, Subsurface Investigation Report, prepared for Telegraph Business Properties, April 15, 1994, 6 pages and 5 appendices.

³ Sierra Environmental Services, 1994, Quarterly Monitoring Report, prepared for Telegraph Business Properties, May 4, 1994, 2 pages and 4 appendices.

⁴ Flatland Deposits of the San Francisco Bay Region, California--Their Geology and Engineering Properties, and Their Importance to Comprehensive planning, E.J. Helley and K.R. Lajoie, U.S. Geological Survey, Geological Survey Professional Paper 943, 88 pages.



John Legallet
July 19, 1994
SES Project #4-719-09

Page 3

surface, and a low- to moderate-permeability silty sand unit from approximately seven to thirty feet below ground surface.⁵

INTERIM REMEDIATION SYSTEM

To reduce hydrocarbon concentrations in ground water and provide hydraulic containment at the site, SES proposes to install a ground water extraction and treatment system. The system will utilize low-flow pneumatic pumps to extract ground water from extraction and/or monitoring wells at the site (Figure 2, Appendix A). Effluent water from the pumps will be piped to activated carbon canisters for removal of hydrocarbons and Volatile Organic Compounds (VOCs).

Pumps will be installed in proposed extraction wells EW-1 and EW-2 (Figure 2, Appendix A). Installation procedures for extraction wells EW-1 and EW-2 (and EW-3, if necessary) will follow procedures described in the SES work plan dated May, 1993, and modified in the ACDEH letter dated November, 1993.^{6,7} Monitoring well MW-2 will be redeveloped and a recovery rate will be calculated. If the recovery rate is sufficient for extraction, an additional pump will be installed in MW-2. If the recovery rate of MW-2 proves insufficient, an additional extraction well (EW-3) will be installed and used as the third extraction point. The underlying geology may limit the extraction rate to less than 2 gallons per minute (GPM) per well.

Effluent from the pumps will be routed through double-contained lines and prefilter(s) into activated carbon canisters for removal of hydrocarbons VOCs by adsorption. Treated ground water will be discharged to the sanitary sewer system under permit from the East Bay Municipal Utilities District. A system schematic is included as Figure 3 (Appendix A).

⁵ Sierra Environmental Services, 1994, Subsurface Investigation Report, prepared for Telegraph Business Properties, April 15, 1994, 6 pages and 5 appendices.

⁶ Sierra Environmental Services, 1993, Subsurface Investigation Work Plan, Telegraph Business Park, 5427 Telegraph Avenue, Oakland, California, May 11, 1993, 5 pages and 3 appendices.

⁷ Alameda County Health Care Services Agency, 1993, Letter from Susan Hugo, Department of Environmental Health, to Jon Legallet, Telegraph Business Properties, November 4, 1993, 3 pages.



John Legallet
July 19, 1994
SES Project #4-719-09

Page 4

The pumps selected for the system are the Clean Environment Engineers, Inc. (CEE) Model ADDP-1 shallow well total fluid extraction pump and/or the CEE Model AP-4/TL total fluid extraction pump. The pumps are pneumatically powered, with an adjustable flow rate and have low maintenance requirements. An air compressor will be installed to power the pumps.

Two 1,000-pound carbon treatment units will be connected in series to treat extracted ground water. The first unit will treat the water to below detectable concentrations, and the second unit will ensure hydrocarbons or VOCs are not discharged should the first unit reach adsorption capacity. Unit costs, recharge rates, and available space will determine the specific carbon container type. Westates Carbon (Oakland, California) will supply and service the carbon units. Manufacturer's equipment specifications for the key system components are included as Appendix C.

The system will be contained on a concrete pad approximately 12' x 20'. The pad area will have a six-inch formed concrete berm to provide sufficient secondary containment for the volume of water within the treatment equipment. In addition to the prefilter(s), a settling tank may be installed to remove coarse-grained sediments and provide surge protection for the system.



John Legallet
July 19, 1994
SES Project #4-719-09

Page 5

Construction and permitting for the interim remediation system will commence immediately following work plan approval. Please call if you have any questions regarding this work plan.

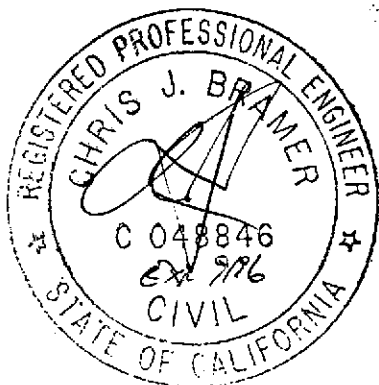

Sincerely,
Sierra Environmental Services

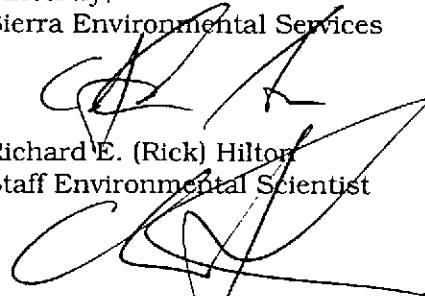

Richard E. (Rick) Hilton
Staff Environmental Scientist



Chris Bramer
Professional Engineer #C48846

CJB/REH/lmo
71909WP1.JL4

Attachments: Appendix A - Figures
Appendix B - Tables
Appendix C - Manufacturer's Equipment Data

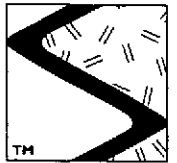

SIERRA

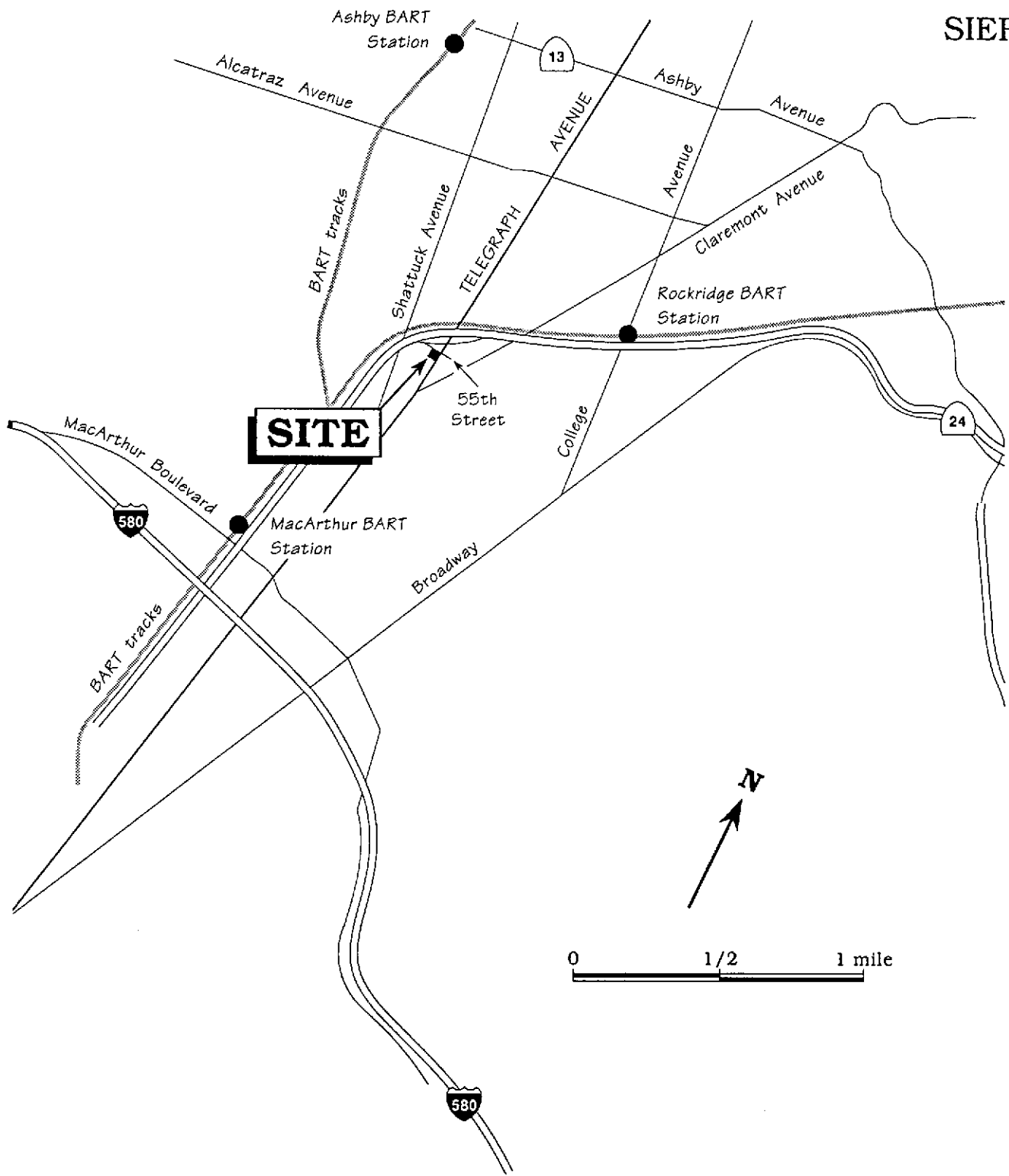

Base map ref: California State Automobile Association (AAA)

Figure 1. Site Location Map - Telegraph Business Park, 5427 Telegraph Avenue, Oakland, California

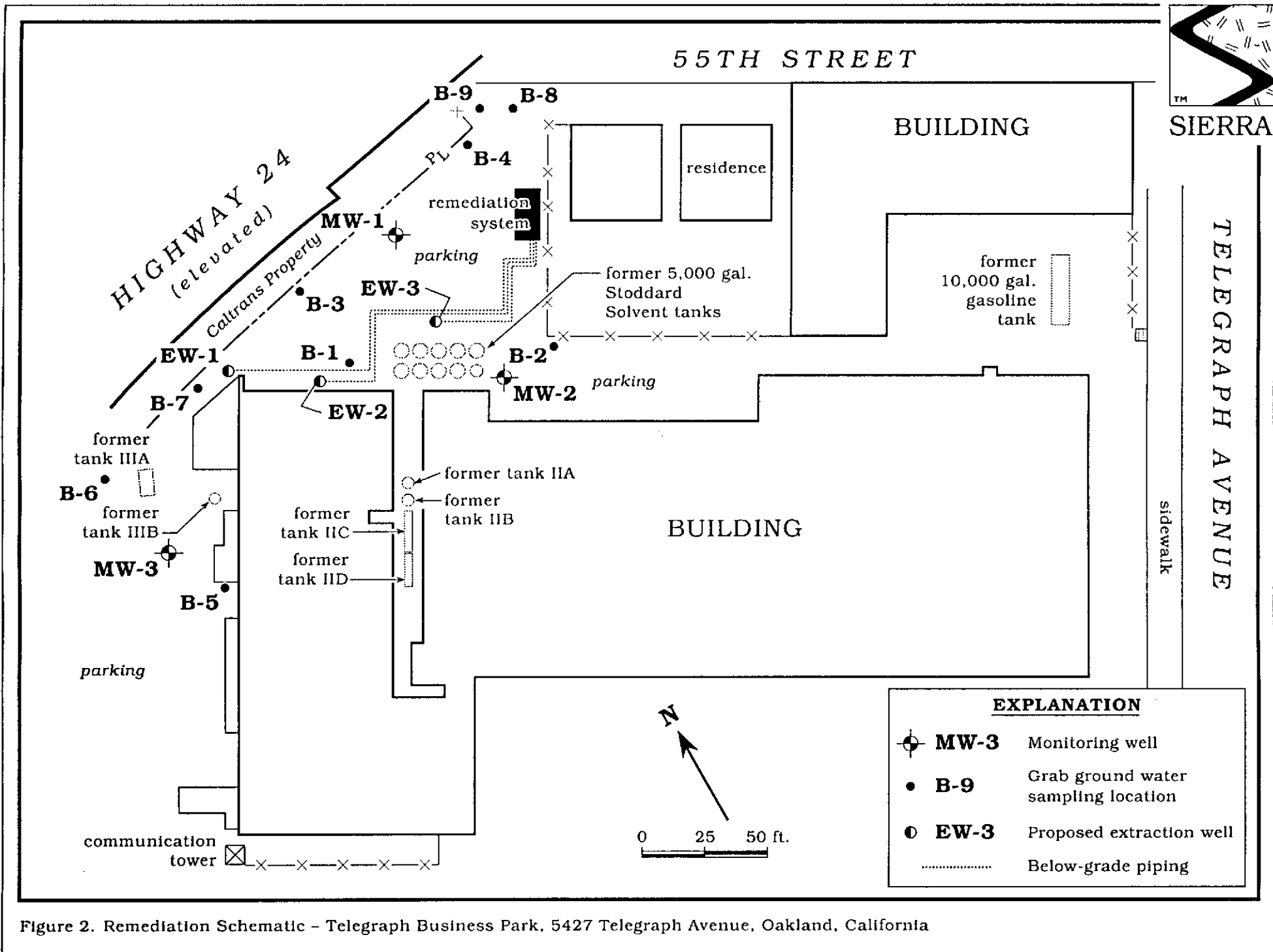

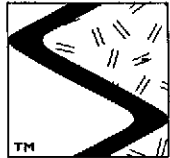

SIERRA

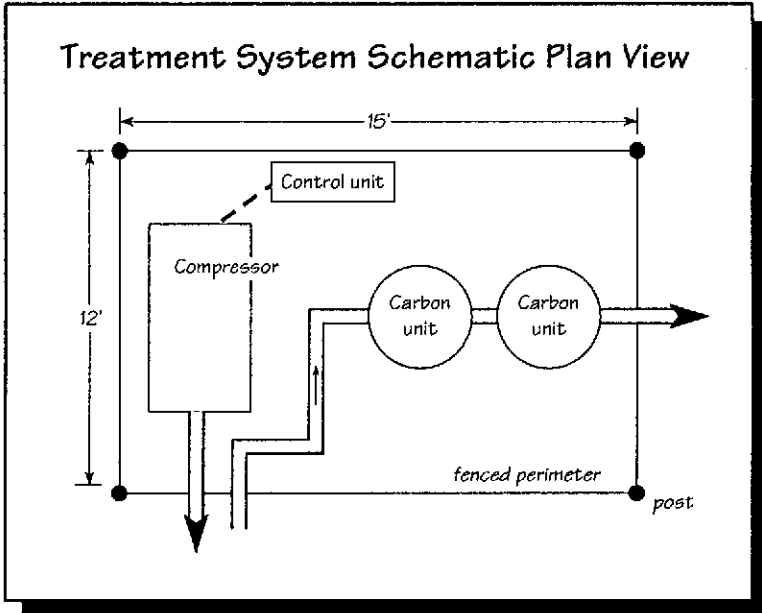
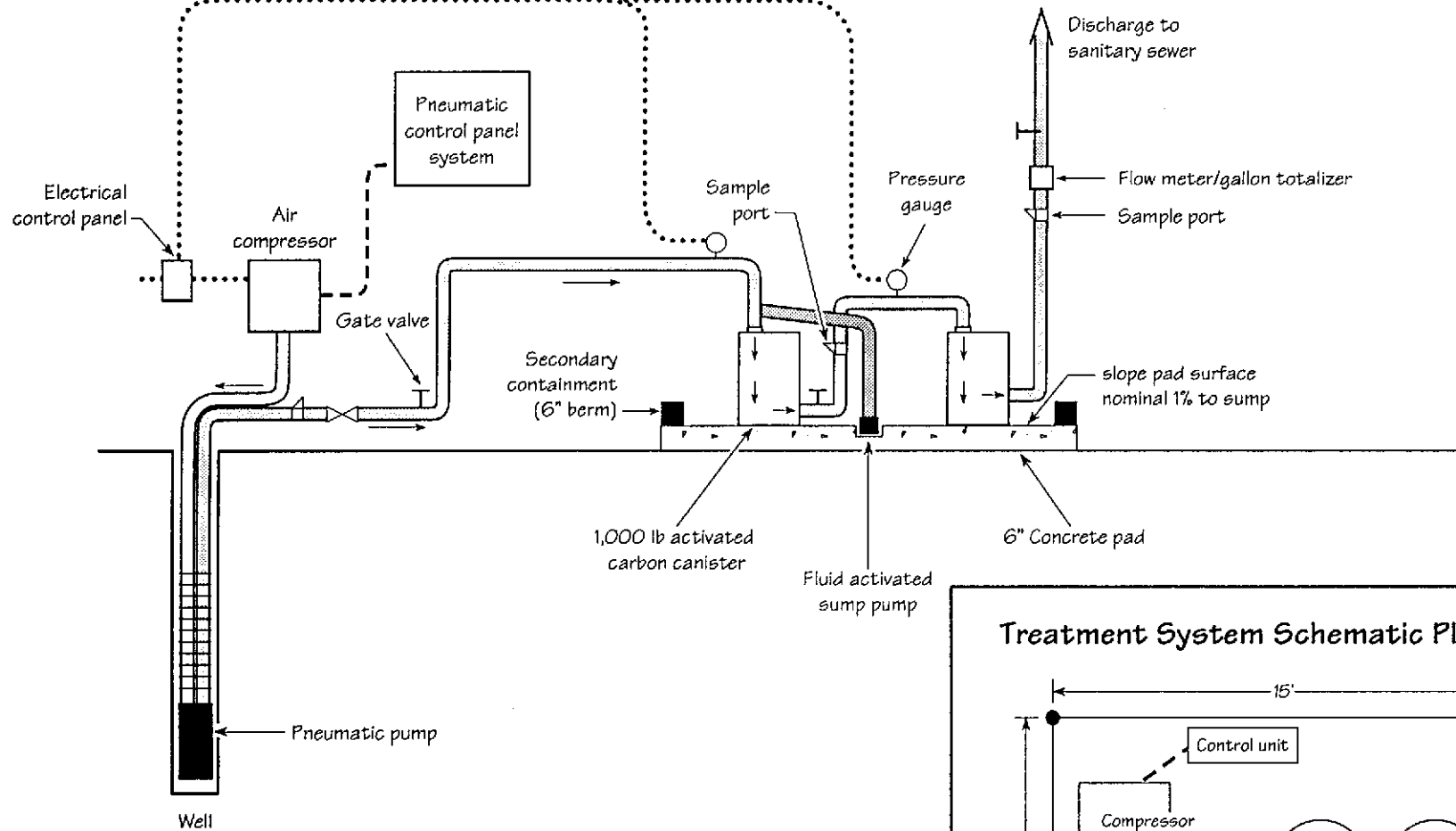

Figure 3. Schematic Diagram of Ground Water Treatment System - Telegraph Business Park - 5427 Telegraph Avenue, Oakland, California



SIERRA

Table 1. Analytic Results for Ground Water - Petroleum Hydrocarbons - Telegraph Business Park, 5427 Telegraph Avenue, Oakland, California

Sample ID	Date Sampled	Analytic Method	TPH(D)	Stoddard Solvent	O&G	ppb			
						B	T	E	X
B-1	12/13/93	LUFT	1,200	93,000	---	---	---	---	---
B-2	12/13/93	LUFT	4,000	1,400,000	---	---	---	---	---
B-3	12/13/93	LUFT	3,700	780,000	---	---	---	---	---
B-4	12/13/93	LUFT	90	15,000	---	---	---	---	---
B-5	12/14/93	LUFT	100	1,600	---	---	---	---	---
B-6	12/14/93	LUFT	460	9,000	---	---	---	---	---
B-7	12/14/93	LUFT	390	18,000	---	---	---	---	---
B-8	12/14/93	LUFT	<50	<50	---	---	---	---	---
B-9	12/14/93	LUFT	<50	60	---	---	---	---	---
MW-1	1/5/94	LUFT/602	500	1,000	6,300*	3.3	1.6	<0.3	6.0
	4/6/94	LUFT/602/5520	800	1,400	<5,000	5.6	4.5	<0.3	11
MW-2	1/5/94	LUFT/602	200	35,000	<5,000	12	38	<3.0	150
	4/6/94	LUFT/602/5520	2,200	94,000	15,600	21	22	<6.0	110
MW-3	1/5/94	LUFT/602	70	1,100	<5,000	180	20	85	10
	4/6/94	LUFT/602/5520	<50	1,000	<5,000	140	13	60	<12
Trip Blank									
TB-LB	1/5/94	602	---	---	---	<0.3	<0.3	<0.3	<0.3
	4/6/94	602	---	---	---	<0.3	<0.3	<0.3	<0.6
Bailer Blank									
BB	1/5/94	602	---	---	---	<0.3	<0.3	<0.3	<0.3
	4/6/94	602	---	---	---	<0.3	0.8	<0.3	<0.6

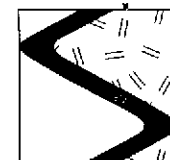

SIERRA

Table 1. Analytic Results for Ground Water - Petroleum Hydrocarbons - Telegraph Business Park, 5427 Telegraph Avenue, Oakland, California (continued)

EXPLANATION:

TPH(D) = Total Petroleum Hydrocarbons as Diesel
O&G = Oil and Grease
HC = Hydrocarbons
B = Benzene
T = Toluene
E = Ethylbenzene
X = Xylenes
HVOCs = Halogenated Volatile Organic Compounds
LUFT = Leaking Underground Fuel Tanks
ppb = Parts per billion
--- = Not analyzed/Not applicable

ANALYTIC LABORATORY:

All samples analyzed by Precision Analytical Laboratory, Inc. of Richmond, California.

ANALYTIC METHODS:

LUFT = Department of Health Services LUFT Manual Method for TPH(D), Stoddard Solvent, and O&G
602 = EPA Method 602 for BTEX
5520 = Standard Methods Method 5520 F for total hydrocarbons analysis (non-polar).

NOTES:

* This result represents both naturally occurring organics and petroleum hydrocarbons due to its analysis by Standard Methods Method 5520B.

CLEAN ENVIRONMENT EQUIPMENT

SPECIFICATIONS FOR THE ADDP-1 **TOTAL FLUIDS REMOVAL SYSTEM**

This is a pneumatically powered system that is designed for the removal of "total fluids" or "water only" from a 2" diameter well or greater, to depths of 22 feet. The system will consist of an air filter, regulator, well level sensor, pump and hoses all mounted on an aluminum plate frame having two sides. The ADDP system is suitable for outdoor use.

AIR FILTER/REGULATOR

The air filter shall filter the air to 5 microns and be able to remove some oil and water from the compressed air. It shall have an automatic float drain. The regulator shall be able to regulate the compressed air from 0 to 125 psi. Both the air filter and the regulator shall have metal bowls and be able to withstand 250 psi air pressure.

WELL LEVEL SENSOR

The system operates without a pneumatic control box. The ADDP-1 is fully automatic with a bubbler sensor which activates the pump to match the fluid influx into the well, up to the stated capacities.

FLUID(S) PUMP

The ADDP-1 total fluids pump is a 1" double diaphragm, air driven pump that is located out of the well casing. Pressurization causes the diaphragms to be driven back and forth continuously until the compressed air source is removed. The pump will draw fluids from the well and discharge them at the surface.

CAPACITY

The maximum suggested sustained run, utilizing this 1" double diaphragm pump, is 8 gpm. The maximum rate for runs of short duration is 15 gpm. Larger pumps are available for sustaining higher recovery rates.

ADDP-1 SHALLOW WELL TOTAL FLUIDS REMOVAL SYSTEM

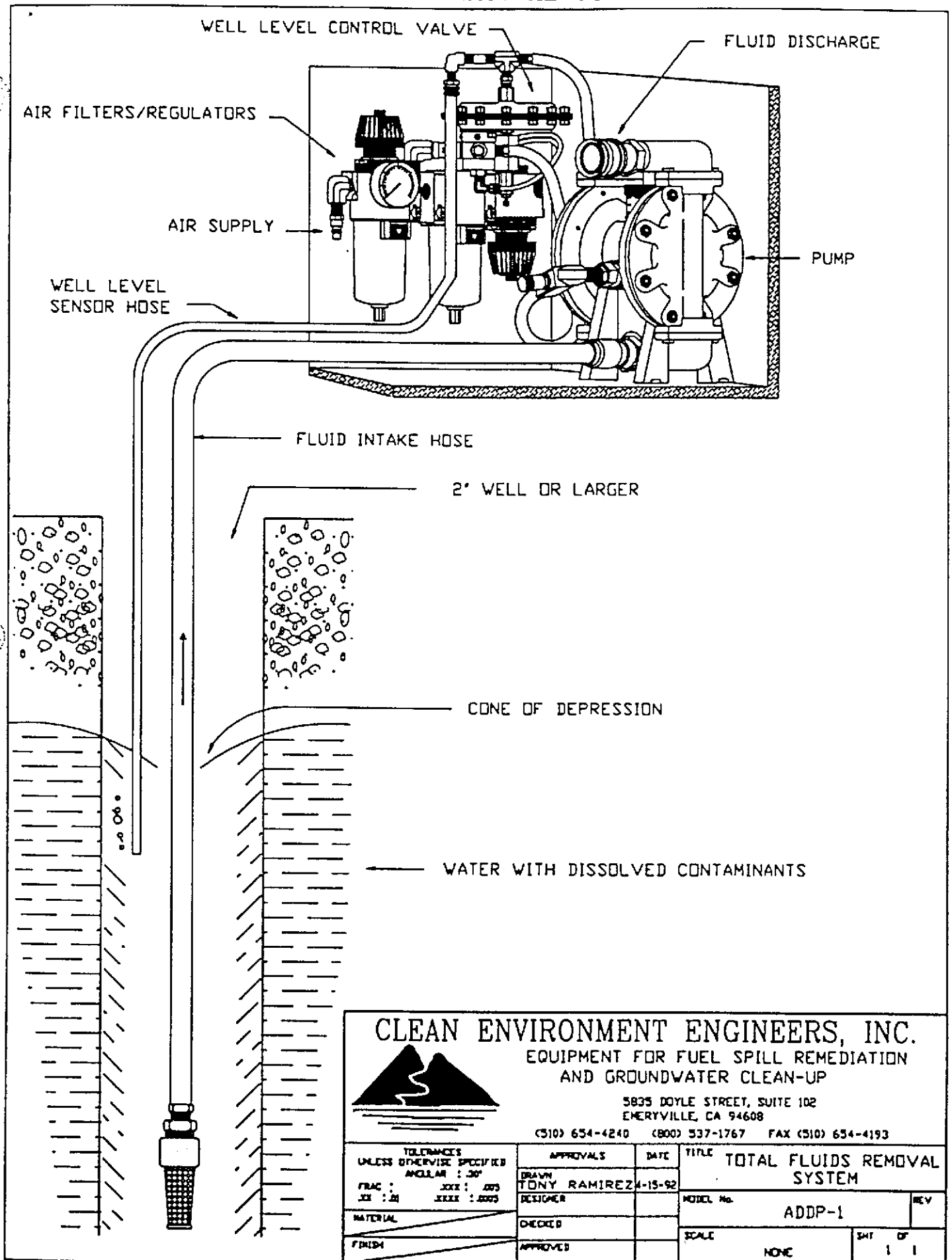

CLEAN ENVIRONMENT ENGINEERS, INC.

EQUIPMENT FOR FUEL SPILL REMEDIATION
AND GROUNDWATER CLEAN-UP

5835 DOYLE STREET, SUITE 102
EMERYVILLE, CA 94608

(510) 654-4240 (800) 537-1767 FAX (510) 654-4193

<p>TOLERANCES UNLESS OTHERWISE SPECIFIED ANGULAR : 30° FRAC : .XXX : .005 DIM : .XX : .0005</p>	<p>APPROVALS</p> <p>DRAWN TONY RAMIREZ</p> <p>DESIGNER</p>	<p>DATE</p> <p>4-15-92</p>	<p>TITLE</p> <p style="text-align: center;">TOTAL FLUIDS REMOVAL SYSTEM</p>
<p>MATERIAL</p>	<p>CHECKED</p>	<p>MODEL No.</p> <p style="text-align: center;">ADDP-1</p>	<p>REV</p>
<p>FINISH</p>	<p>APPROVED</p>	<p>SCALE</p> <p style="text-align: center;">NONE</p>	<p>SHT OF</p> <p style="text-align: center;">1 1</p>

ADDP-1

CLEAN ENVIRONMENT EQUIPMENT

SPECIFICATIONS FOR THE AP-4 AUTO PUMP

A "CONTROLLERLESS" PNEUMATIC PUMP FOR TOTAL FLUIDS REMOVAL

SHORT PUMP, TOP LOADING CONFIGURATION SHORT AP-4/TL

Page 1 of 3

The pumping system shall be powered solely by compressed air with all controls located inside the pump. It shall be capable of removing water and product (e.g. oil, fuels, solvents, etc.) from a well casing of four (4) inch diameter or greater to depths of at least 250 feet. The fluid inlet shall be located above the pump body as to take in water and lighter-than-water products.

Pump

The pump shall have all pump controls inside the pump. There shall be no timers, bubbler or air valves external to the pump needed to operate the pump. The pump shall use air only when pushing fluid out of the pump and not use any air while the fluid is filling the pump. The pump shall have three hoses - a hose for pressurized air to run the pump; a hose for the exhaust air to exit the pump and a hose for the fluid to be discharged from the pump. These hoses are to be attached to the pump using brass quick connect fittings with locking sleeves. The air valves inside the pump shall be stainless steel poppets. The air valves will be able to pass water and ninety (90) weight oil at 70°F without fouling.

The pump shall be able to pump three A(3) gallons per minute using 80 psi air and three (3) feet submergence of the inlet. The air pressure to the pump need only be a maximum of 10 psi greater than the total developed head of the system for the pump to automatically operate whenever it fills with fluid. When the pump is empty, the air from the pump shall be exhausted through the exhaust air hose, allowing fluid to enter the pump. When the pump is full, compressed air is to be fed into the pump through the compressed air supply hose to push the collected fluid out of the pump. This cycle shall continue automatically.

Standard materials of construction shall be stainless steel, brass, Delrin, nylon, Viton, Teflon and FRP.

Pump Air Valve Description

1. The pump valve design shall need only two hoses - air input and air exhaust.
2. The pump shall be able to function with inlet air pressures ranging from 5 to 150 psi.
3. **There shall be two pump air valves - one for air inlet and one for air exhaust. These valves shall be of a poppet design with the poppet design with the poppets moving vertically.**
4. The poppets for the pump air valves shall be stainless steel.
5. **The pump poppet valves shall be mounted on a lever assembly to facilitate a mechanical advantage for the poppet valves to actuate reliably. A float shall activate the lever assembly and thus shift the poppet valves.**
6. Compressor lubrication oil and water shall pass from the compressed air supply hose thorough the air valves easily. The air valves shall be able to pass 90 weight oil at 70° F at a rate of at least 8 ounces per minute using 80 psi air pressure.
7. **The pump air valve shall use air only when discharging fluid from the pump.** The air valve assembly shall not need a bleeding air supply to facilitate operations.
8. The air valve shall be able to allow the fluid being pumped to rise up through the valve when the compressed air source is removed from the pump. **The pump shall thus be able to sit submerged and dormant for at least two (2) days and to start up readily** and continue to function when compressed air is again applied to the pump.

Pump Internals

1. The fluid discharge pipe of the pump shall be stainless steel.
2. The fluid discharge pipe of the pump shall serve as the tension member between the top and bottom of the pump.
3. The spring shall be a stainless steel alloy.
4. The pump shall supply a volume of at least 0.25 gallons per cycle at zero discharge head and 30 psi air supply.

Pump Fluid Valves

1. The inlet of the pump shall be 40 inches or less above the bottom of the pump.
2. The inlet and outlet check valve shall be located above the pump body for easy access.
3. The inlet and outlet check valves shall be located in one fitting located on the fluid discharge pipe, for easy access and servicing.
4. The inlet check valve shall be a free-floating, self-cleaning ball check valve.
5. The outlet check valve shall be a free-floating, self-cleaning ball check valve.

Flow Rate

The pump shall be able to remove at least 2.0 gpm with an 80 psi air supply, the inlet submerged 3 feet and pumping against a 15 psi head.

Without any head, the pump shall be able to pump 3.0 gallons per minute with 80 psi air pressure and the inlet submerged of 3 feet.

Compressed Air Filter/Regulator

The air filter shall filter the air to 5 microns and be able to remove some oil and water from the compressed air. It shall have an automatic float drain. The regulator shall be able to regulate the compressed air from 0 to 250 psi. The air filter shall have metal bowls and both the air filter and regulator shall be able to withstand 250 psi air pressure.

Hoses

All hoses supplied with the system shall be of industrial grade. The hoses shall equal or surpass **GOODYEAR INSTAGRIP I** hose quality. All hoses shall be color coded and equipped with non-interchangeable brass quick connect fittings.

AP-4 SHORT TOP LOADING AUTO PUMP TOTAL FLUIDS REMOVAL SYSTEM

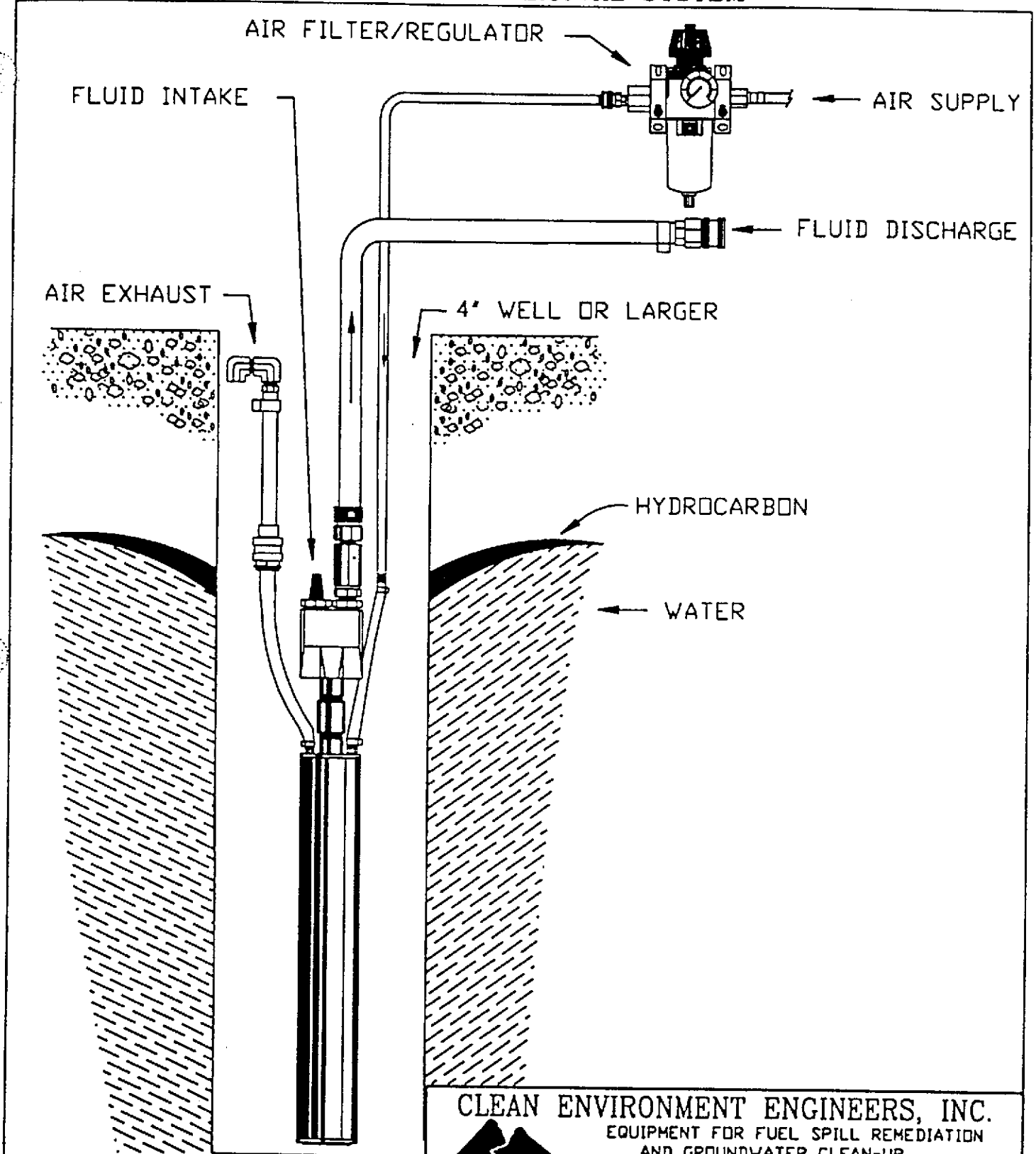

CLEAN ENVIRONMENT ENGINEERS, INC.
 EQUIPMENT FOR FUEL SPILL REMEDIATION
 AND GROUNDWATER CLEAN-UP

5835 DOYLE STREET, SUITE 102
 EMERYVILLE, CA 94608
 (415) 654-4240 (800) 337-1767 FAX (415) 654-4193

<p>TOLERANCES UNLESS OTHERWISE SPECIFIED ANGULAR : 30° FIN : 32 DIA : .005 HOLE : .005 TYP : .005</p>	<p>APPROVALS DATE</p> <p>DRAWN TONY RAMIREZ 03-92</p> <p>CHECKED</p> <p>APPROVED</p>	<p>TITLE TOTAL FLUIDS REMOVAL SYSTEM</p> <p>MODEL NO. SHORT TOP LOADING AUTO PUMP (AP-4)</p> <p>SCALE NONE SHEET OF 1 1</p>
---	--	--

Quality Certified

AQUA-Carb

Water Treatment Carbons

DESCRIPTION

Westates' AQUA-CARB™ activated carbons are high performance adsorbants specifically designed for water treatment. Manufactured from unique high quality substrates, AQUA-CARB activated carbons feature internal pore structures that are ideally suited to remove organic compounds from water. High removal efficiency coupled with their very low water soluble ash content make AQUA-CARB activated carbons the best value for your water treatment needs.

QUALITY CERTIFIED

The process for manufacturing activated carbons involves procedures with many variables that require strict quality control. Westates maintains a modern ASTM quality control laboratory to certify that Westates products meet or exceed all required specifications.



Coconut Shell at 2.2kx mag.

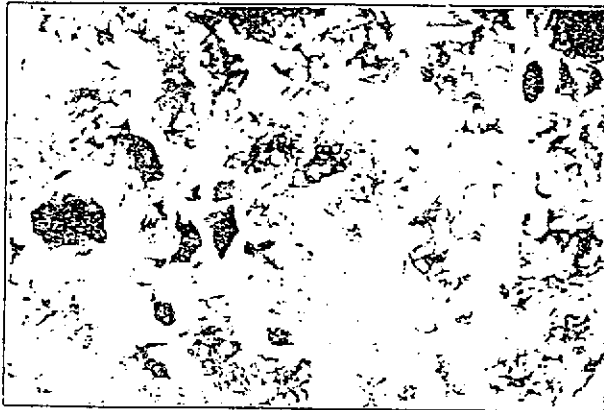

Bituminous Coal at 250x mag

SAFETY

Wet activated carbon readily adsorbs atmospheric oxygen. Dangerously low oxygen levels may exist in closed vessels or poorly ventilated storage areas. Workers should follow all applicable state and federal safety guidelines for entering oxygen depleted areas.

WESTATES CAPABILITIES

Westates has the facilities for manufacturing, regenerating and characterizing activated carbon. Selected high quality carbons are also available from other sources giving Westates the capability of supplying the best carbon for your treatment needs. We have more than 20 years experience in the design of activated carbon adsorption systems. Our technical staff provides expert advice in selecting the right carbon for your needs. Our laboratories are equipped to provide complete quality control and a continuing analysis of your carbon to maintain maximum efficiency.

All information presented here is believed to be reliable and in accordance with accepted engineering practice. However, Westates makes no warranties as to the completeness of the information. Users should evaluate the suitability of each product to their own particular application. In no case will Westates be liable for any special, indirect, or consequential damages arising from the sale, resale, or misuse of its products.

SPECIFICATIONS

	CO-401	KP-401	CC-601	CC-401
Size (US Sieve)	8 - 30	8 - 30	12 x 30	12 x 30
Iodine No. (Mint)	900	850	900	900
Hardness No. (Mint)	97	92	99	99
Abrasion No. (Mint)	76	76	99	99
Moisture (Mint)	10	10	10	10
Mean Particle Diam.	1.15mm	1.2mm	1.2mm	1.2mm
Shape	Granule	Pellet	Granule	Granule
Ph Water Extract	15	15	15	15
Soluble Phosphate	N/D	N/D	N/D	N/D
Ash (Water Soluble)	1.5	1.5	1.5	1.5
Apparent Density (g/cc)	49	49	52	55
(lb/ft ³)	30.5	30.5	32.5	34

(Refer to selection guide on reverse.)



WESTATES CARBON, INC
2130 Leu Ave., Los Angeles, CA 90040
PHONE (213) 722-7500
FAX (213) 722-6207 FAX 910 821 2155

Water Purification System

AQUA-SCRUB™

ASC-200

EASY TO INSTALL

AQUA-SCRUB™ adsorbers are designed for fast and easy installation on any hard, flat surface. The only hardware needed is properly sized pipe or flexible hose for connection to the inlet/outlet ports. It is strongly recommended that a particulate filter be installed upstream from the AQUA-SCRUB™ adsorber.

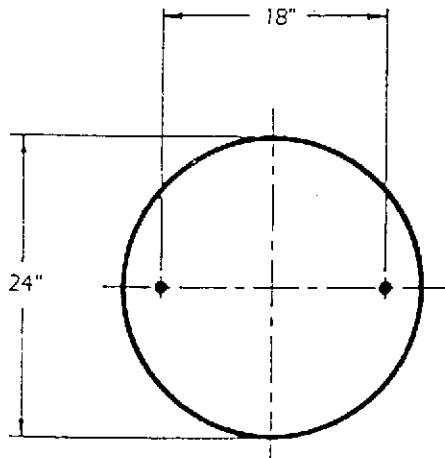

CORROSION RESISTANCE

The combination of activated carbon and many VOC's can cause severe corrosion to metals, even stainless steel. AQUA-SCRUB™ adsorbers are designed to prevent these effects in normal service.

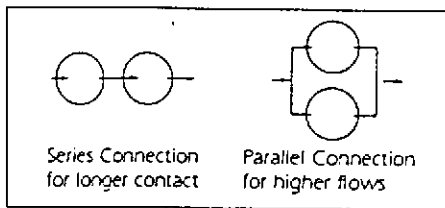

MATERIALS OF CONSTRUCTION

Vessel: Coated Carbon Steel
 External Coating: Powder Coat Enamel
 Internal Coating: Polyethylene Lined
 Piping: PVC

START-UP

Before beginning operation, AQUA-SCRUB™ adsorbers must be backfilled with water or liquid to be treated, and allowed to stand overnight to wet the carbon and eliminate all air (entrapped air is the most common cause of channeling).

OUTLET 3/4" HOSE THREAD

INLET 3/4" HOSE THREAD

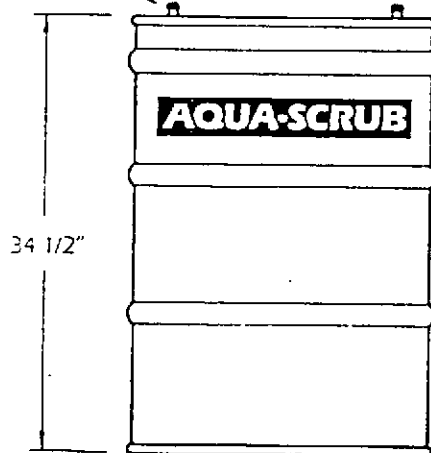

PRESSURE DROP

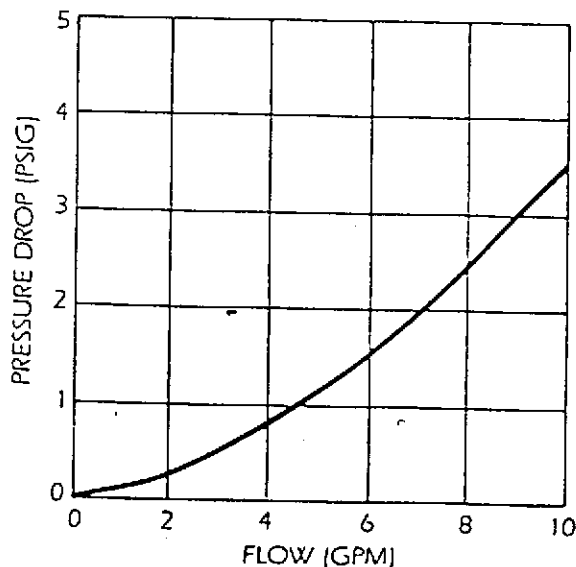

SPECIFICATIONS

Flow* gpm (max)
 Pressure psig (max)
 Temperature deg F (max)
 Carbon Fill Volume (cu. ft.)
 Cross Section (sq. ft.)
 Shipping Weight (lbs.)

ASC-200-.75

10
 12
 120
 6.5
 3.0
 250

*Note: actual equipment selection should be based on required retention time.

All information presented here is believed to be reliable and in accordance with accepted engineering practice. However, Westates makes no warranties as to the completeness of the information. Users should evaluate the suitability of each product to their own particular application. In no case will Westates be liable for any special, indirect, or consequential damages arising from the sale, resale, or misuse of its products.



WESTATES CARBON, INC.
 2130 Leo Ave., Los Angeles, CA 90040
 PHONE: (213) 722-7500
 FAX: (213) 722-8207 Tlx: 910-321-2355

Water Purification System

AQUA-SCRUB™

ASC-1200 ASC-2000

EASY TO INSTALL

AQUA-SCRUB™ adsorbers are designed for fast and easy installation on any hard, flat surface. The only hardware needed is properly sized pipe or flexible hose for connection to the inlet/outlet ports. It is strongly recommended that a particulate filter be installed upstream from the AQUA-SCRUB™ adsorber.

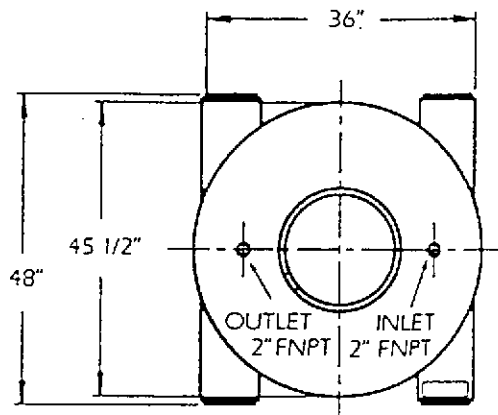

CORROSION RESISTANCE

The combination of activated carbon and many VOC's can cause severe corrosion to metals, even stainless steel. AQUA-SCRUB™ adsorbers are designed to prevent these effects in normal service.

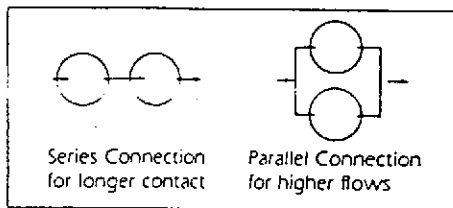

START-UP

Before beginning operation, AQUA-SCRUB™ adsorbers must be backfilled with water or liquid to be treated, and allowed to stand overnight to wet the carbon and eliminate all air (entrapped air is the most common cause of channeling).

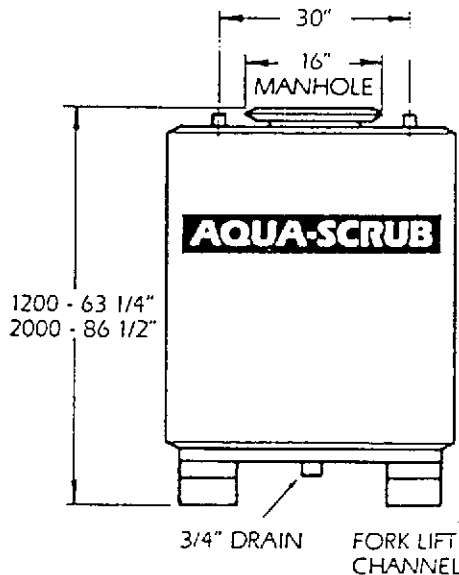

MATERIALS OF CONSTRUCTION

Vessel: 12 ga. Carbon Steel Shell
7 ga. Top/Bottom
External Coating:
Powder Coat Enamel
Internal Coating:
Fusion Bonded Epoxy
Piping: PVC

PRESSURE DROP

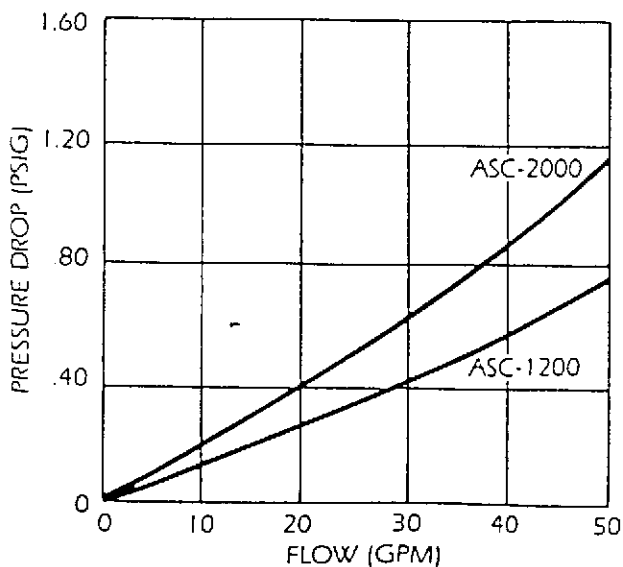

SPECIFICATIONS

	ASC-1200-2	ASC-2000-2
Flow* gpm (max)	50	50
Pressure psig (max)	12	12
Temperature deg F (max)	120	120
Carbon Fill Volume (cu. ft.)	33	65
Cross Section (sq. ft.)	11.2	11.2
Shipping Weight (lbs)	1600	2500

*Note: actual equipment selection should be based on required retention time

All information presented here is believed to be reliable and in accordance with accepted engineering practice. However, Westates makes no warranties as to the completeness of the information. Users should evaluate the suitability of each product to their own particular application. In no case will Westates be liable for any special, indirect, or consequential damages arising from the sale, resale, or misuse of its products.



WESTATES CARBON, INC.
2130 Leo Ave., Los Angeles, CA 90040
PHONE (213) 722-7500
FAX (213) 722-6207 TWX 910-321-2355