

HARRISON STREET

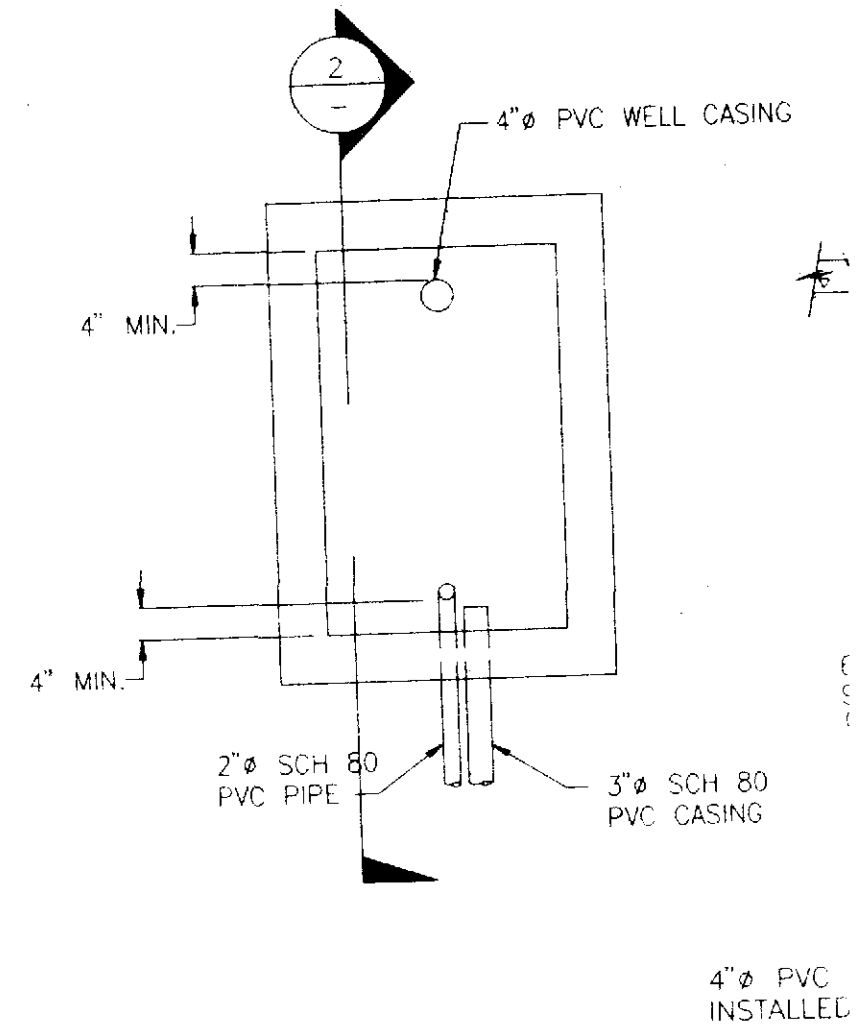

PLAN

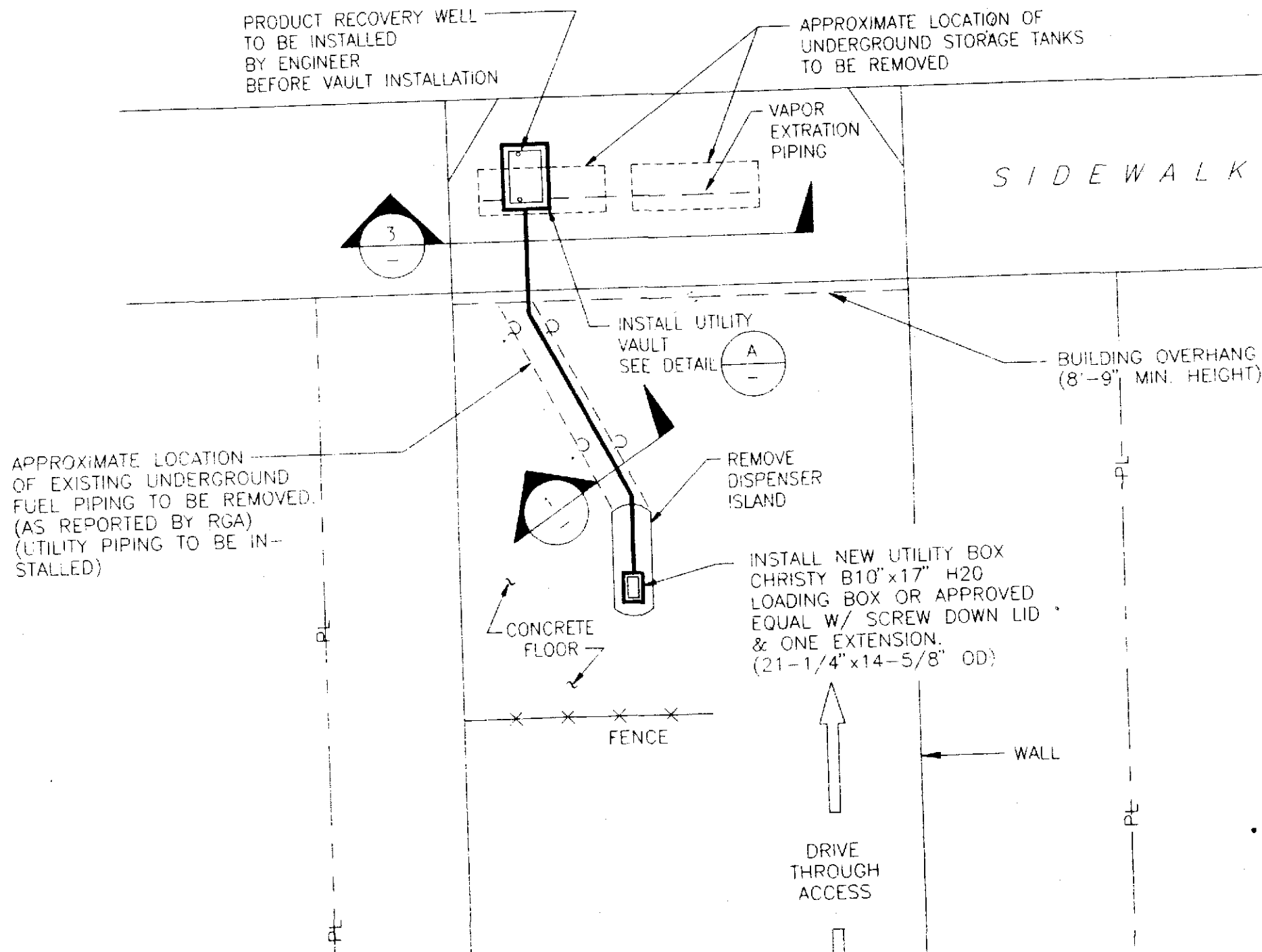
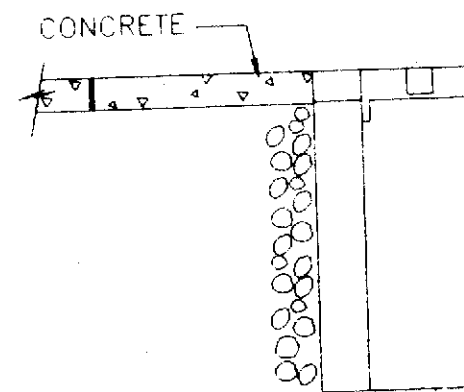
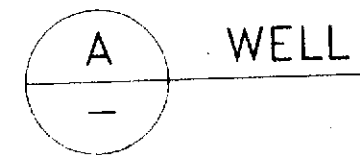

GENERAL NOTES

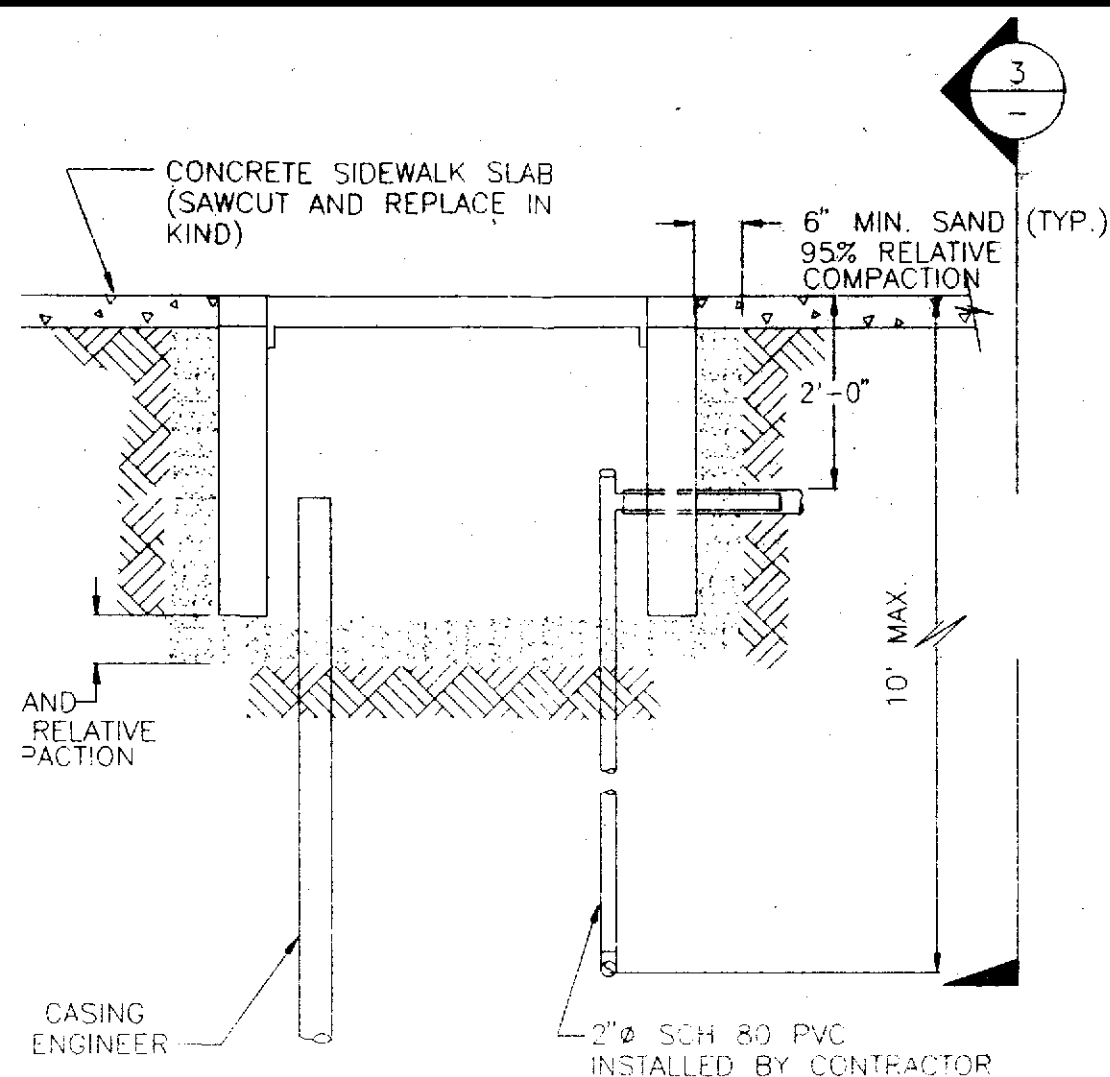

2 SECTION

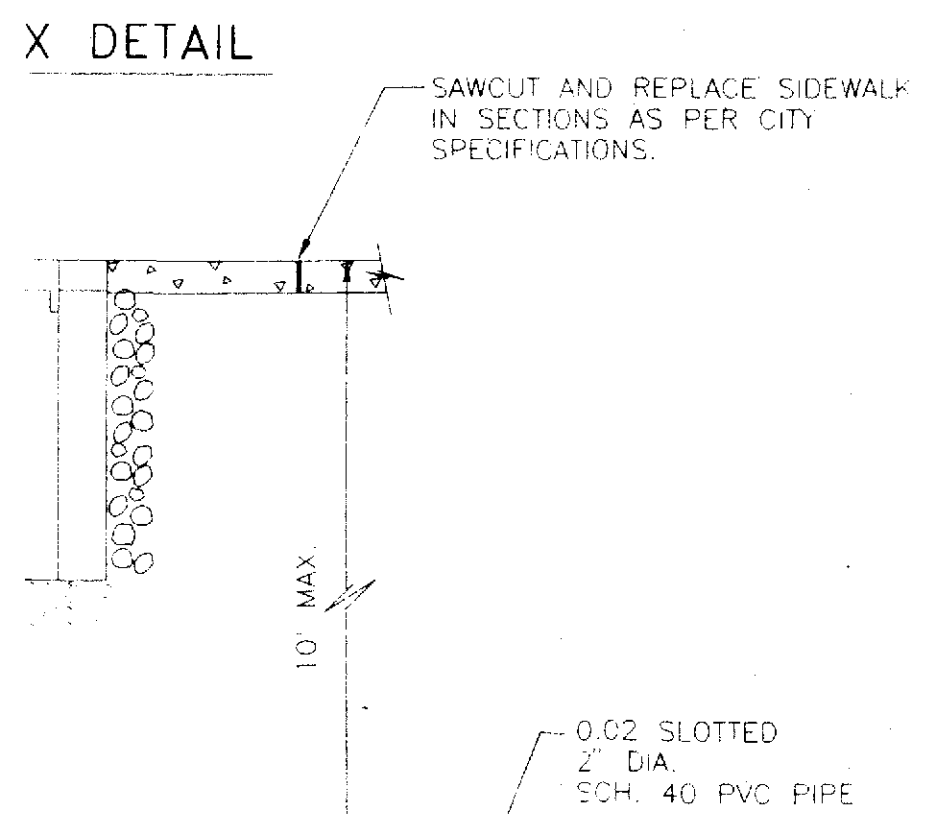

1. THE LOCATION AND DEPTHS OF EXISTING UNDERGROUND UTILITIES AND IMPROVEMENTS ARE NOT SHOWN. THEIR LOCATIONS HAVE NOT BEEN VERIFIED IN THE FIELD AND NO GUARANTEE IS MADE TO THE ACCURACY OF THE INFORMATION SHOWN. IT SHALL BE THE CONTRACTOR'S RESPONSIBILITY TO DETERMINE THE EXTENT AND LOCATION OF ALL UNDERGROUND UTILITIES. THE CONTRACTOR SHALL NOTIFY UTILITY COMPANIES AT LEAST 48 HOURS IN ADVANCE OF CONSTRUCTION TO FIELD LOCATE UTILITIES. THE CONTRACTOR SHALL CONTACT UNDERGROUND SERVICE ALERT AT 800-642-2444. ANY ADDED COST ON THE PART OF THE CONTRACTOR AS A RESULT OF THE ACTUAL LOCATIONS OF EXISTING UTILITIES BEING DIFFERENT FROM THOSE SHOWN ON THE PLANS SHALL BE BORNE BY THE CONTRACTOR.
2. ALL EXISTING UTILITIES AND IMPROVEMENTS THAT BECOME DAMAGED DURING CONSTRUCTION SHALL BE COMPLETELY RESTORED TO THE SATISFACTION OF THE CITY ENGINEER AT THE CONTRACTOR'S OWN EXPENSE. THE CONTRACTOR SHALL BE HELD RESPONSIBLE FOR ANY FIELD CHANGES MADE WITHOUT WRITTEN AUTHORIZATION FROM THE ENGINEER.
3. ANY RELOCATION OF PUBLIC UTILITIES SHALL BE CONDUCTED IN ACCORDANCE WITH ANY AND ALL REQUIREMENTS OF THE UTILITY COMPANY AFFECTED, INCLUDING FEES, BONDS, PERMITS AND WORKING CONDITIONS, ETC. THIS WORK SHALL BE DONE AT NO EXPENSE TO THE LOCAL AGENCIES.
4. EXCAVATION SHALL BE ADEQUATELY SHORED, BRACED AND SHEETED SO THAT THE EARTH WILL NOT SLIDE OR SETTLE AND SO THAT ALL EXISTING IMPROVEMENTS OF ANY KIND WILL BE FULLY PROTECTED FROM DAMAGE. ANY DAMAGE RESULTING FROM A LACK OF ADEQUATE SHORING, BRACING OR SHEETING SHALL BE THE RESPONSIBILITY OF THE CONTRACTOR, AND HE SHALL EFFECT NECESSARY REPAIRS FOR RECONSTRUCTION AT HIS OWN EXPENSE. WHERE THE EXCAVATION FOR A CONDUIT TRENCH STRUCTURE IS 5 FEET OR MORE IN DEPTH, THE CONTRACTOR SHALL PROVIDE ADEQUATE SHEETING, SHORING AND BRACING OR EQUIVALENT METHOD FOR THE PROTECTION OF THE WORKERS. SAID PROTECTION SHALL CONFORM TO THE APPLICABLE CONSTRUCTION SAFETY ORDERS OF THE PROVISIONS FOR INDUSTRIAL SAFETY OF THE STATE OF CALIFORNIA. THE CONTRACTOR SHALL ALWAYS COMPLY WITH OSHA REQUIREMENTS.
5. THE CONTRACTOR SHALL PROVIDE ALL LIGHTS, SIGNALS, BARRICADES, FLAGMAN, OR OTHER DEVICES NECESSARY TO PROVIDE FOR SAFETY.
6. THE CONTRACTOR SHALL MAINTAIN FOR INGRESS AND EGRESS FOR PROPERTY ADJACENT TO WORK THROUGHOUT THE DURATION OF CONSTRUCTION.
7. ALL MATERIALS AND WORKMANSHIP SHALL FULLY CONFORM WITH THE SPECIFICATIONS, STANDARDS AND ORDINANCES OF THE CITY OF OAKLAND. SPECIFICATIONS AND DETAILS ARE AVAILABLE IN THE OFFICE OF THE CITY ENGINEER. IF THE SPECIFICATIONS DO NOT ADDRESS AN ITEM, THE WORK SHALL BE DONE IN ACCORDANCE WITH THE LATEST STANDARD SPECIFICATIONS. CONSTRUCTION DETAILS FROM STANDARD DRAWINGS FROM THE STATE OF CALIFORNIA, DEPARTMENT OF TRANSPORTATION, UNLESS OTHERWISE NOTED IN THESE PLANS AND SPECIFICATIONS.
8. ALL ALIGNMENTS, OFFSETS, AND GRADES SHALL BE VERIFIED BY CONTRACTOR IN THE FIELD. IF FIELD ADJUSTMENTS ARE REQUIRED, THE CONTRACTOR SHALL IMMEDIATELY NOTIFY THE ENGINEER BEFORE PROCEEDING WITH ANY ALTERATION TO THE LOCATIONS AS SHOWN.
9. ALL TRENCHING SHALL BE BARRICADED, DELINEATED, COVERED WITH TEMPORARY STEEL PLATES, OR OTHERWISE PROTECTED FROM TRAFFIC, AS NECESSARY, BY THE CONTRACTOR.
10. ANY CURB OR GUTTERS REMOVED OR DAMAGED SHALL BE REPLACED IN KIND TO NEAREST GUTTER JOINTS.
11. ALL CONSTRUCTION AND WORKMANSHIP SHALL CONFORM TO THE 1991 UNIFORM BUILDING CODE OR LOCAL CODE WHICHEVER IS MORE RESTRICTIVE.

1. CONCRETE SIDEWALK AND FLOOR TO BE REPLACED IN KIND.

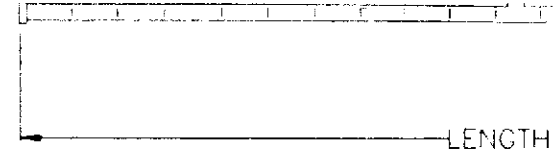

SITE LAYOUT

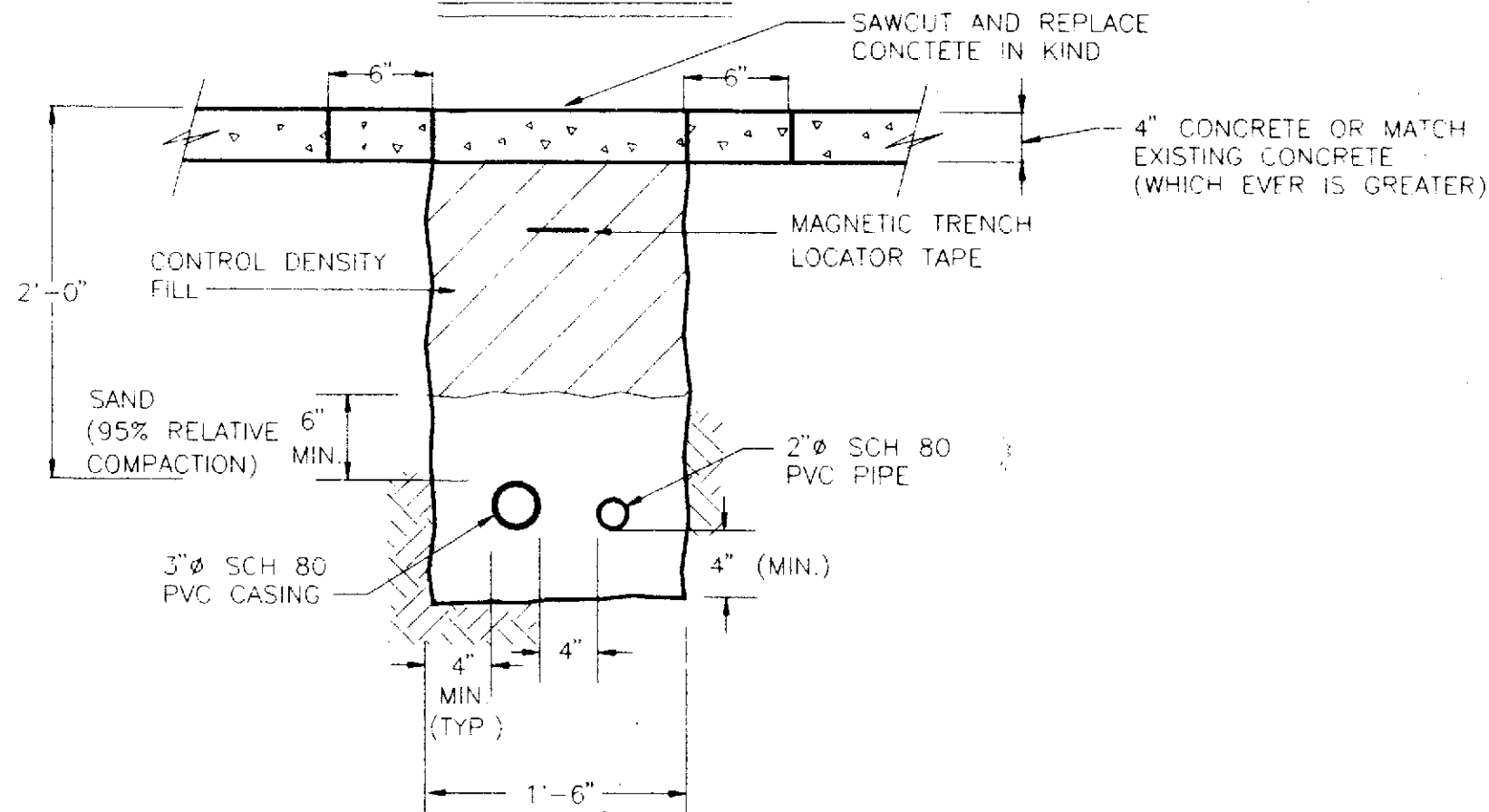

3

No. 3048 TRAFFIC H-20 COVER, GALVANIZED. TORSION SPRING ASSEMBLY. FRAME HEIGHT ADJUSTABLE.

Height Adjustment Bracket

VAULT 6646-LA-SPEC 8'-0" I.D. WT. 43.85 LB.

1 UTILITY TRENCH SECTION
N.T.S.

B UTILITY

REVISION	DESIGN	DRAWN	CHECKED	DATE	AS BID :
					DESIGN : RER
					DRAWN : NNM
					CHECKED : RER

LEVINE • FRICKE
CONSULTING ENGINEERS AND HYDROGEOLOGISTS

Emeryville, California

SHOWN, THEY DO NOT INDICATE THE METHOD OF CONSTRUCTION. THE CONTRACTOR SHALL SUPERVISE AND DIRECT THE WORK AND HE SHALL BE SOLELY RESPONSIBLE FOR ALL CONSTRUCTION MEANS, METHODS, TECHNIQUES, SEQUENCES, AND PROCEDURES.

13. ALL ERECTION PROCEDURES SHALL CONFORM TO THE OSHA STANDARDS. DEVIATION MUST BE APPROVED BY OSHA PRIOR TO ERECTION.
14. DESIGN, MATERIALS, EQUIPMENT AND PRODUCTS OTHER THAN THOSE DESCRIBED BELOW OR INDICATED ON THE DRAWINGS MAY BE CONSIDERED FOR USE, PROVIDED PRIOR APPROVAL IS OBTAINED FROM THE ENGINEER, AND THE APPLICABLE GOVERNING CODE AUTHORITY.

CONSTRUCTION MATERIAL NOTES

CONCRETE

1. NO PIPES OR DUCTS ARE TO BE PLACED IN CONCRETE SLABS UNLESS SPECIFICALLY DETAILED.
2. AGGREGATES SHALL BE NATURAL SAND AND ROCK CONFORMING TO ASTM C33.
3. ALL CONCRETE SHALL ATTAIN A MINIMUM COMPRESSIVE STRENGTH AT 28 DAYS AS FOLLOWS: 3000 PSI FOR FOOTINGS AND SLAB ON GRADES.
4. LAP ALL BARS A MINIMUM OF 40 BAR DIAMETERS (2'-0" MINIMUM) AT SPLICES AND 24 BAR DIAMETER HOOK AT CORNERS UNLESS NOTED OTHERWISE.
5. MINIMUM CONCRETE COVERAGE : THE FOLLOWING MINIMUM CLEAR DISTANCES BETWEEN REINFORCING STEEL AND FACE OF CONCRETE SHALL BE MAINTAINED UNLESS NOTED OTHERWISE :
 - UNDER-GROUND - 3" BOTTOM
 - 2" TOP
 - 3" SIDE
6. REINFORCING STEEL SHALL CONFORM TO ASTM A615, GRADE 40 FOR #3 AND SMALLER, GRADE 60 FOR #4 AND LARGER.
7. REINFORCING FABRIC SHALL CONFORM TO ASTM A185.
8. CEMENT SHALL BE PORTLAND CEMENT CONFORMING TO ASTM C-150, TYPE I OR II, LOW ALKALI.
9. CONTRACTOR TO TAKE AND STORE TEST CYLINDER OF CONCRETE AS PER UNIFORM BUILDING CODE REQUIREMENTS
10. EPOXY GROUTED ANCHOR BOLTS SHALL BE 3/4" DIA HILTI HVA ADHESIVE CONCRETE ANCHORS WITH 4" EMBEDMENT, ICBO REPORT NO. 4016, DECEMBER 1988 OR APPROVED EQUAL.

TANKS EXCAVATION
(FEET MAX)

SECTION

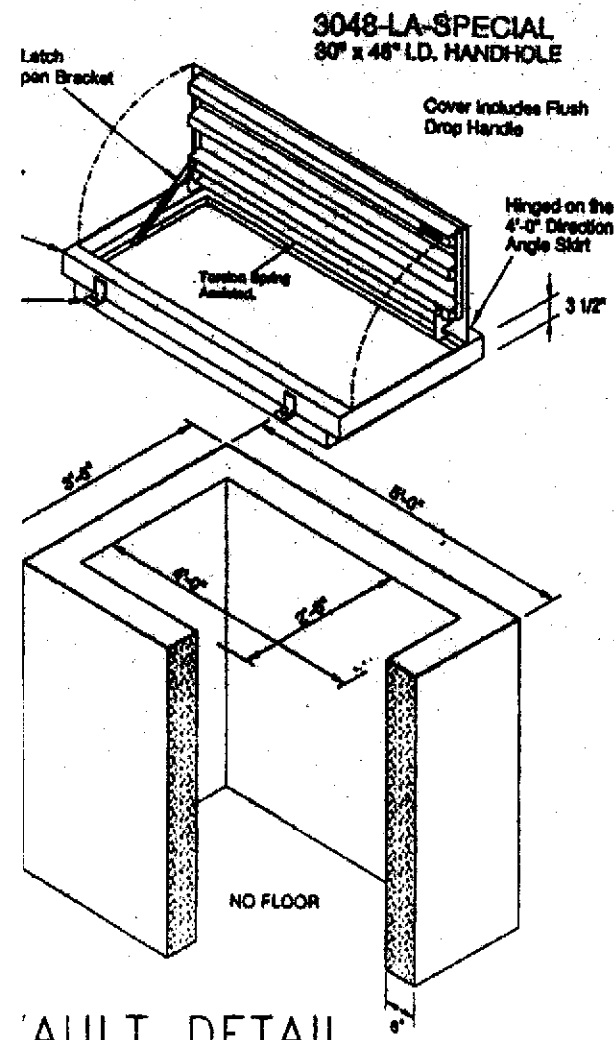

UTILITY VAULT
MODEL #3048-LA
OR APPROVED EQUAL.

VAULT DETAIL

I.T.S.

APPROVED : SENIOR ENGINEER DATE	Harrison St. Garage 1432-1434 Harrison St. Oakland, California	UNDERGROUND TANK REMOVAL PLAN	Project No. 2680.22
		SITE PLAN, SECTIONS & DETAILS	Date OCT. 93
			Sheet 2 of 2

P L A N S

**Underground Tank F
Project**

Prepared for

Alvin H. Bacharach

emoval

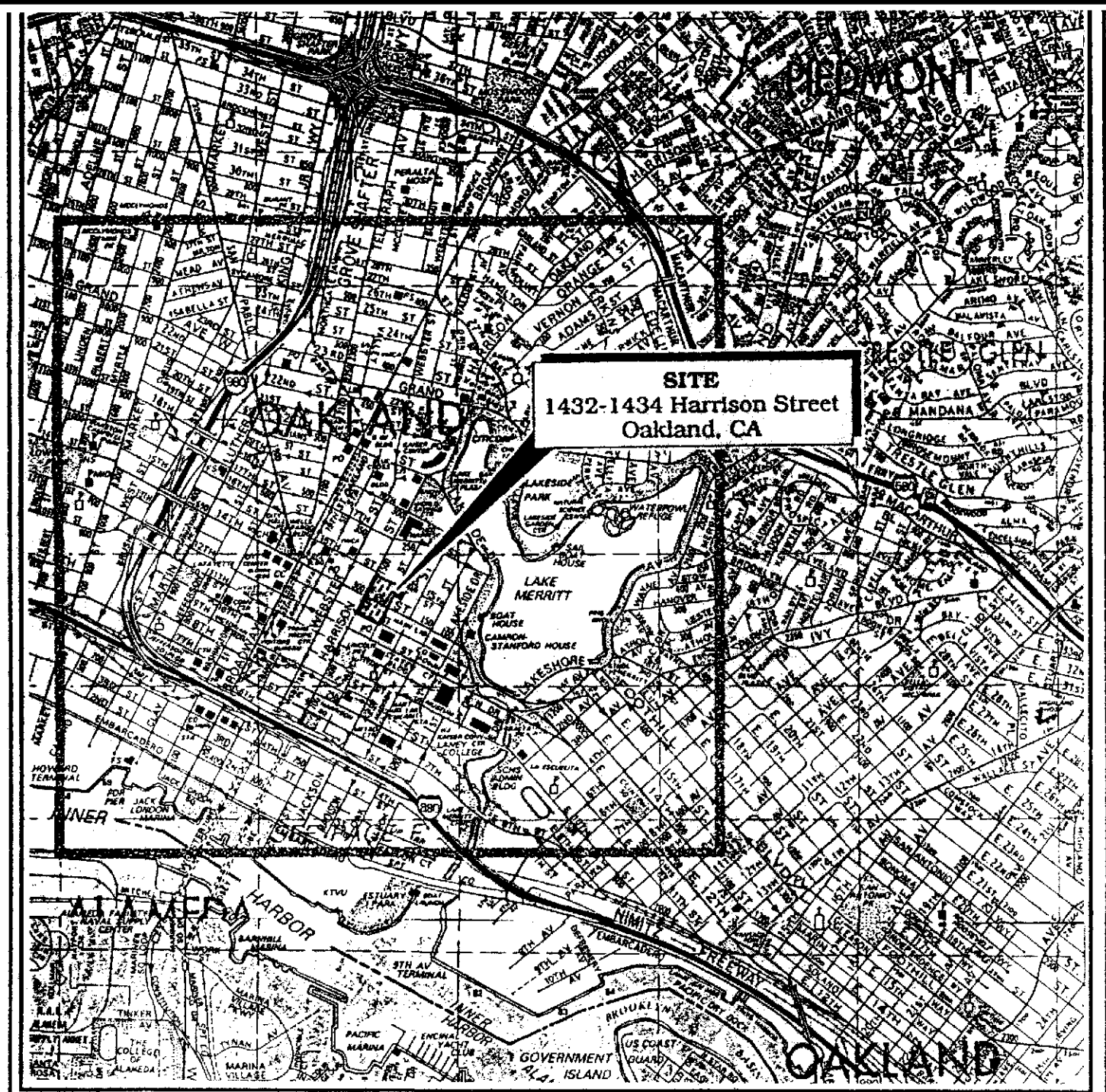

SITE
1432-1434 Harrison Street
Oakland, CA



0 1/2 1 MILE

MAP SOURCE:
Thomas Bros. Map
Alameda and Contra Costa Counties
EDITION 1992

VICINITY MAP

ENCLOSURE AND EXAMINATION

505 DIABLO ROAD, Suite
Danville, Ca. 94526

by

LEVINE•FRICKE, INC.

1900 Powell St., 12th Fl
Emeryville, Ca. 94608

REVISION	DESIGN	DRAWN	CHECKED	DATE	AS BID :
					DESIGN : <u>NNM</u>
					DRAWN : <u>NNM</u>
					CHECKED : <u>RER</u>



LEVINE•FRICKE
CONSULTING ENGINEERS AND HYDROGEOLOGISTS

Emeryville, California

00

or

TITLE SHEET, VICINITY MAP, AND
INDEX OF DRAWINGS

1 OF 2

SITE PLAN, SECTIONS & DETAILS

2 OF 2

APPROVED :	Harrison St. Garage 1432-1434 Harrison St. Oakland, California	UNDERGROUND TANK REMOVAL PLAN	Project No. 2680.22
		TITLE SHEET, VICINITY MAP AND INDEX OF DRAWINGS	Date OCT. 93
SENIOR ENGINEER	DATE		Sheet 1 of 2

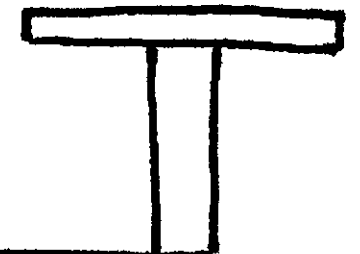
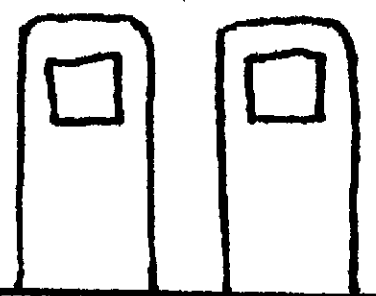

	(17)	(18)	(19)	(20)	(21)	(22)	(23)
TPHg	2.5		2.1	2.0	1.9	42.3	2.5
TPHd	28		24	22.7	15.7	670	26
BTEX	LOL		LOL(φH)	LOL(φH)	LOL(φH)	LOL(φH)	LOL(φH)
TOG	39.1						
PCB	LOL						
HCCI	LOL						

(5')	(13)	(14)	(15)
TPHg	8.32	LOL	
TPHd	1.63	LOL	
φH	LOL	LOL	
TEX	(Low)	(Low)	
PCB	LOL	LOL	
HCCI	LOL	LOL	LOL

	(22)	(23)
(10')	TPHg 1540	3.3
	TPHd 175	LOL
	BTEX 0.987(φH)	LOL(φH)

	(10/19/90)
(10')	TPHg 1700
	TOG 6300

	(10/19/90)
(13')	TPHg ND
	BTEX ND

	(21)
(15')	TPHg 2.1
	TPHd 16.7
	BTEX LOL(φH)

(15')	(13)	(14)	(15)
TPHg	135	2.5	
TPHd	LOL	17.3	
φH	(NT)	(NT)	
TEX	(NT/Low)	(NT)	
PCB	LOL	LOL	
HCCI	LOL	LOL	LOL

(11)

(15') (21)
 TPHg 2.1
 TPHd 16.7
 BTEX LOL (PH)

TPHd LOL 17.3 (NT)
 PH (NT)
 TEX (NT/Low)
 PCB LOL
 HCCl LOL LOL

(8/18/90)

25' TPHg 9300
 PH 98

(8/18/90) (10/19/90)

10' PH 900 TPHg 6300 2500
 PH 190 PH 99 3.5
 PH 1100 PH 490 34
 PH 110 33
 PH 610 130

(Water)
 (17)

(Water) (Water) (Water) (Water)
 (20) (21) (22) (23)

TPHg	LOL	96 ppb	LOL	72 ppb	1020 ppb
TPHd	LOL	LOL	LOL	LOL	LOL
PH	4.0 ppb	5.0 ppb	LOL	5.0 ppb	6.0 ppb
PH	LOL	6.0 ppb	LOL	6.7 ppb	3.0 ppb
PH	LOL	LOL	LOL	LOL	2.0 ppb
PH	LOL	LOL	LOL	3.0 ppb	7.9 ppb
HCCl	2.4 (HCCl ₂ Bv)				

(10/19/90) (10/19/90)

(22.5') TPHg 1200 110
 PH 3.5 0.24
 PH 34 0.21
 PH 33 0.69
 PH 130 1.3

(Water)
 (13)
 TPHg 60,200 ppb
 TPHd LOL
 PH 55 ppb
 TEX (Low)
 TUG 9721

Blue = RGA, Inc.

Red = Subsurface Consultants, Inc.

All data shown in ppm unless indicated otherwise

Vertical distances 1/2" = 1'; Horizontal distances not to scale

	(1)	(2)	(3)	(4)	(5)	(6)	(7)	(8)	(9)	(10)
(2 ¹) TPH _g	27.3	1.6		1.9			2.6			
TPH _d	55.7	1.5	1.6	2.4	2.5	24.3	6.3	2.9		
TOG	54.2	LOL	LOL	54.8	50.9	LOL	22.1	55.1		
φH	LOL	LOL	LOL	LOL	LOL	LOL	LOL	LOL		
TEX (Low)	(Low)	(Low)	(Low)	(Low)	(Low)	(Low)	(Low)	(Low)	(9)	
PCB	LOL	LOL	LOL	LOL	LOL	LOL	LOL	LOL		
HCCI	LOL	LOL	LOL	LOL	LOL	LOL	LOL	LOL		

w/o

(5¹) TPH_g 2.44
 TPH_d 11.1
 BTEX (NT)
 PCB LOL
 HCCI LOL

(10/19/90)
 (9¹) Kerosene 98
 BTEX N/D
 TOG N/D
 PCB 9 ppb

(8¹) TPH_d 109
 BTEX (NT)
 PCB LOL
 HCCI LOL

(9.5¹) Kerosene 140
 TPH_d N/D
 TOG N/D