

RECEIVED

By dehloptoxic at 1:26 pm, Jul 07, 2006

SECOND QUARTER 2006 BIOVENTING STATUS REPORT

**REDWOOD REGIONAL PARK
SERVICE YARD
OAKLAND, CALIFORNIA**

Prepared for:

**EAST BAY REGIONAL PARK DISTRICT
OAKLAND, CALIFORNIA**

July 2006

July 5, 2006

Mr. Jerry Wickham, P.G.
Hazardous Materials Specialist
Alameda County Department of Environmental Health
1131 Harbor Bay Parkway, Suite 250
Alameda, California 94502

Subject: Second Quarter 2006 Bioventing Progress Report
Redwood Regional Park Service Yard Site, Oakland, California – RO #0000246

Dear Mr. Wickham:

This report discusses activities conducted during the Second Quarter of 2006 related to a bioventing corrective action system at the Redwood Regional Park Service Yard, located at 7867 Redwood Road, Oakland, California. This project is being conducted for the East Bay Regional Park District, and follows previous site investigation and remediation activities (conducted since 1993). The key regulatory agencies for this investigation are the Alameda County Department of Environmental Health, the Regional Water Quality Control Board, and the California Department of Fish and Game. I declare, under penalty of perjury, that the information and/or recommendations contained in the attached document or report is true and correct to the best of my knowledge.

If you have any questions regarding this report, please contact Mr. Neal Fujita of the East Bay Regional Park District, or contact me directly at (510) 644-3123.

Sincerely,

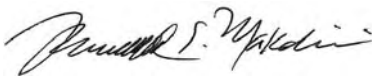

Richard S. Makdisi, R.G., R.E.A.
Principal and Project Manager



cc: Carl Wilcox - California Department of Fish and Game
Neal Fujita - East Bay Regional Park District
State of California GeoTracker system (electronic upload)

**SECOND QUARTER 2006
BIOVENTING STATUS REPORT**

**REDWOOD REGIONAL PARK
SERVICE YARD
OAKLAND, CALIFORNIA**

Prepared for:

**EAST BAY REGIONAL PARK DISTRICT
P.O. BOX 5381
OAKLAND, CALIFORNIA 94605**

Prepared by:

**STELLAR ENVIRONMENTAL SOLUTIONS
2198 SIXTH STREET, SUITE 201
BERKELEY, CALIFORNIA 94710**

July 5, 2006

Project No. 2006-17

TABLE OF CONTENTS

Section	Page
1.0 PROJECT DESCRIPTION AND SITE HISTORY.....	1
Project Description.....	1
Site Description.....	1
Site History and Contamination.....	4
Regulatory Status and Data Reporting.....	5
2.0 BIOVENTING SYSTEM DESCRIPTION	6
3.0 CURRENT QUARTER ACTIVITIES AND FINDINGS	11
System Operation.....	11
O&M Activities.....	11
O&M Findings	12
4.0 SUMMARY, CONCLUSIONS, AND PROPOSED ACTIONS.....	17
Summary and Conclusions.....	17
Proposed Actions	17
5.0 REFERENCES.....	19

Appendices

Appendix A Monthly System O&M Checklists

TABLES AND FIGURES

Tables	Page
Table 1 Bioventing Well Construction Data Redwood Regional Park Service Yard, Oakland, California.....	7

Figure	Page
Figure 1 Site Location on USGS Topographic Map	2
Figure 2 Full Scale Bioventing System Site Plan.....	3
Figure 3 As-Built Vent Well Construction Details	8
Figure 4 As-Built Vapor Monitoring Point Construction Details	9
Figure 5 Bioventing Process Flow and Instrumentation Diagram	10
Figure 6 Historical Groundwater Levels Relative to Top of Bioventing Well Screened Intervals	14
Figure 7 Historical Groundwater Levels Relative to Top of Shallow Vapor Monitoring Point Screened Intervals.....	15
Figure 8 Historical Groundwater Levels Relative to Top of Deep Vapor Monitoring Point Screened Intervals.....	16

1.0 PROJECT DESCRIPTION AND SITE HISTORY

PROJECT DESCRIPTION

The subject property is the East Bay Regional Park District (EBRPD) Redwood Regional Park Service Yard, located at 7867 Redwood Road in Oakland, Alameda County, California. The site has undergone site investigations and remediation since 1993 to address subsurface contamination caused by leakage from one or both of two former underground fuel storage tanks (UFSTs) that contained gasoline and diesel fuel. The Alameda County Health Care Services Agency, Department of Environmental Health (Alameda County Environmental Health) has provided regulatory oversight of the investigation since its inception. Other regulatory agencies with historical involvement in site review include the Regional Water Quality Control Board – San Francisco Bay Region (Water Board) and the California Department of Fish and Game (CDFG).

This report documents the activities conducted in the Second Quarter of 2006 related to a soil bioventing system at the site. Bioventing was selected as an appropriate corrective action to mitigate residual petroleum contamination, based on site conditions, residual contaminant distribution, and results from a previously conducted bioventing pilot test in 2004. The report summarizing the pilot test recommended the installation and operation of a full-scale bioventing system (SES, 2004b), which was approved by Alameda County Environmental Health (Alameda County Environmental Health, 2005b). The bioventing system was installed and started up in December 2005 and January 2006 (SES, 2006a), with the First Quarter Bioventing Status Report issued in April 2006 (SES, 2006b). Alameda County Environmental Health responded to that report in its letter of March 15, 2006, approving the proposed approach of monthly bioventing operations and maintenance (O&M) and reporting.

SITE DESCRIPTION

Figure 1 shows the location of the project site. A site plan showing the full-scale bioventing system is presented on Figure 2.



3-D TopoQuads Copyright © 1999 DeLorme Yarmouth, ME 04096 Source Data: USGS 750 ft Scale: 1 : 25,000 Detail: 13-0 Datum: WGS84



SITE LOCATION ON U.S.G.S. TOPOGRAPHIC MAP

Redwood Reg. Park Service Yard
Oakland, CA

By: MJC

MARCH 2006

Figure 1



2006-17-01

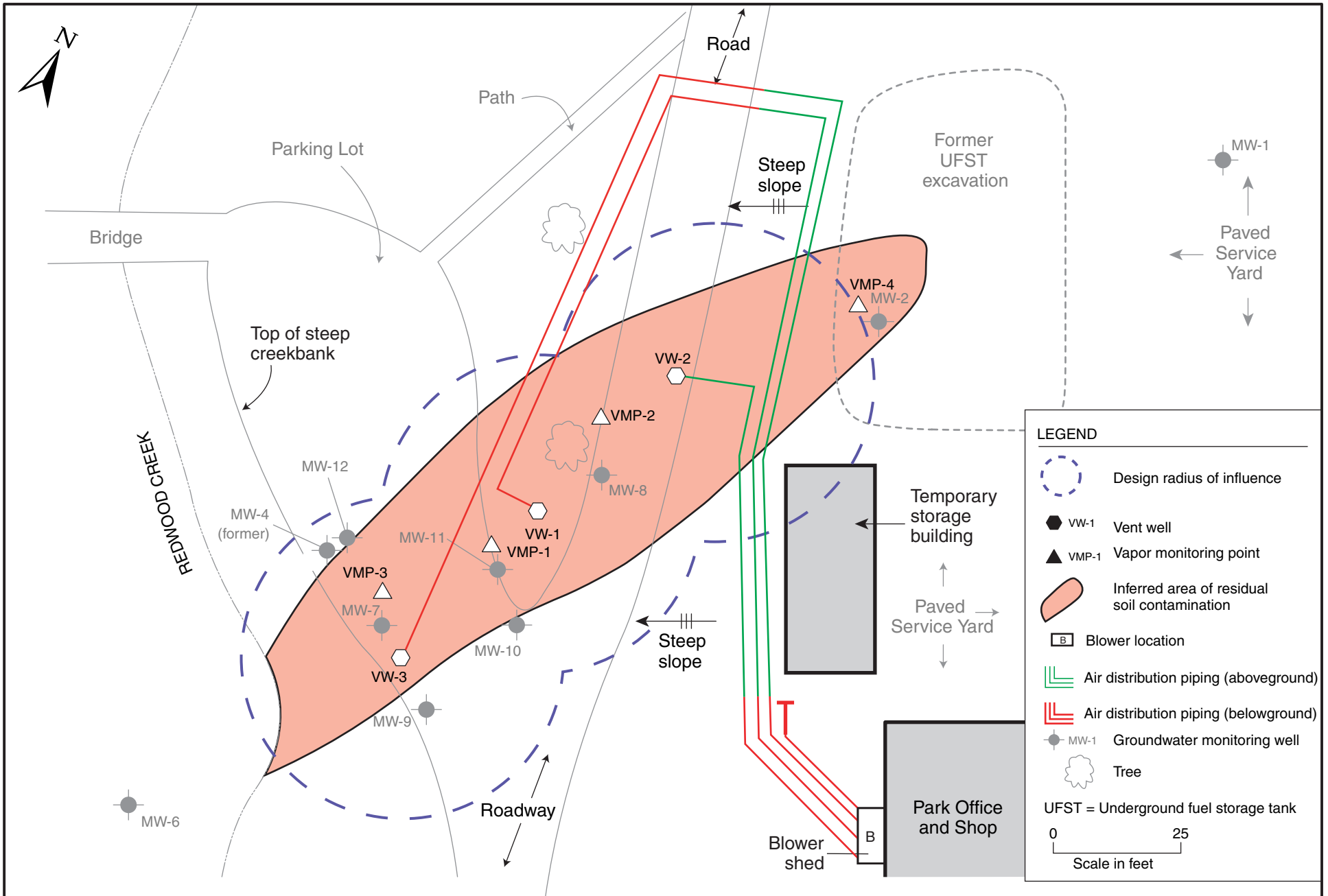

FULL-SCALE BIOVENTING SYSTEM
7867 Redwood Rd, Oakland, CA

Figure 2

by: MJC

DECEMBER 2005

The site slopes to the west, from an elevation of approximately 564 feet above mean sea level (amsl) at the eastern edge of the service yard to approximately 545 feet amsl at Redwood Creek, which defines the approximate western edge of the project site with regard to this investigation.

From east to west, the study area consists of:

- Flat, paved EBRPD service yard with several permanent and temporary buildings/sheds (former UFST excavation area);
- Steep slope (approximately 45 degrees) between the western edge of the service yard and the park entrance road (immediately west of MW-2);
- Hummocky terrain with low vegetation (between MW-8 and MW-11), including a large EBRPD-designated sycamore tree (adjacent to MW-8 and VMP-2);
- Flat, unpaved parking lot (between MW-11 and MW-7); and
- Steep slope (approximately 45 degrees) to Redwood Creek (immediately west of MW-12, MW-7, and MW-9).

SITE HISTORY AND CONTAMINATION

Contaminant corrective actions and investigations have been conducted at the site since 1993. General phases of work previously conducted include:

- Removal of UFSTs and contaminated soil;
- Installation and quarterly monitoring of groundwater monitoring wells;
- Several phases of remedial investigation-oriented exploratory borehole drilling and sampling;
- A correction action feasibility study;
- Two phases of ORC™ injection; and
- An evaluation of bioventing feasibility as a corrective action, which included a bioventing pilot test.

As discussed in detail in previous SES reports, the available data support the following conclusions:

- The saturated zone overlies laterally extensive bedrock, which limits downward migration of groundwater contamination.
- The unsaturated zone varies in thickness due to seasonal water level fluctuations of several feet.

- Site chemicals of concern include total petroleum hydrocarbons (TPH)—specifically as gasoline (TPHg) and diesel (TPHd); benzene, toluene, ethylbenzene, and xylenes (BTEX); and methyl *tertiary*-butyl ether (MTBE).
- Residual soil contaminant mass in the unsaturated zone is acting as a long-term source of groundwater contamination; the maximum thickness of the residual soil contamination (during lowest water level periods) is approximately 10 feet.
- Previous ORC™ injection programs resulted in apparent permanent reductions at the peripheral plume margins, but were followed by rebound to pre-injection conditions within the central portions of the plume, corroborating the conceptual model that remaining unsaturated zone soil contamination is continuing to impact groundwater.
- Site conditions appear favorable for bioventing as a corrective action to reduce unsaturated zone soil contamination, especially in the near-source area that is inaccessible to other methods due to the hilly topography.

REGULATORY STATUS AND DATA REPORTING

The lead regulatory agency for the site investigation and remediation is Alameda County Environmental Health, with oversight provided by the Water Board. The CDFG is also involved with regard to water quality impacts to Redwood Creek. The most recent regulatory agency input was Alameda County Environmental Health’s approval to install and startup the full-scale bioventing system (Alameda County Environmental Health, 2005b), and to implement the monthly bioventing O&M program and conduct an in situ respiration test (Alameda County Environmental Health, 2006).

The site is in compliance with the State Water Resources Control Board’s GeoTracker requirements for uploading of electronic data and reports. In addition, electronic copies of all bioventing-related reports have been uploaded to Alameda County Environmental Health’s online file transfer protocol (ftp) system. Per Alameda County Environmental Health’s October 31, 2005 “Miscellaneous Administrative Topics and Procedures” directive, effective January 31, 2006, paper copies of reports are no longer required to be provided to Alameda County Environmental Health.

2.0 BIOVENTING SYSTEM DESCRIPTION

The bioventing system consists of the following components:

- Three vent wells (VWs), screened across the unsaturated zone.
- Four vapor monitoring points (VMPs), each with two nested screened intervals at depths coincident with VW screened intervals.
- A regenerative-type air blower installed in a small shed on the west side of the service yard garage building. The blower is rated at 140 cubic feet per minute (cfm) and exerts a pressure of approximately 1 to 3 pounds per square inch (psi).
- Air distribution piping between the blower and the VW wellheads, including a manifold just downstream of the blower.
- Appurtenant air flow valves, pressure/vacuum gauges, and air sampling ports.

Table 1 summarizes bioventing well construction data. Figure 2 (in the previous chapter) is a site plan showing the layout of the bioventing system. Figures 3 and 4 are as-builts for typical site VMPs and VWs, respectively. Figure 5 is a flow instrumentation diagram for the blower and associated manifold. This blower system was designed and configured based on the pilot test design specifications—i.e., achieving a potential 30-foot radius of influence and a flow rate of 40 standard cubic foot per minute (scfm) to individual VWs under induced pressure conditions.

Table 1
Bioventing Well Construction Data
Redwood Regional Park Service Yard, Oakland, California

Well	Screen Interval Depth (feet)	Filter Pack Sand Depth Interval (feet)
VW-1	6 – 16	4 – 16
VW-2	8 – 18	6 – 18
VW-3	8 – 18	6 – 18
VMP-1	10 – 11.5	9.5 – 12
	14 – 15.5	13.5 – 16
VMP-2	10 – 11.5	9.5 – 12
	14 – 15.5	13.5 – 16
VMP-3	10 – 11.5	9.5 – 12
	12.5 – 14	12 – 14.5
VMP-4	15.5 – 17	15 – 17.5
	20.5 – 22	20 – 20.5

Note:

All depths are in feet below top of well box (approximately ground surface).

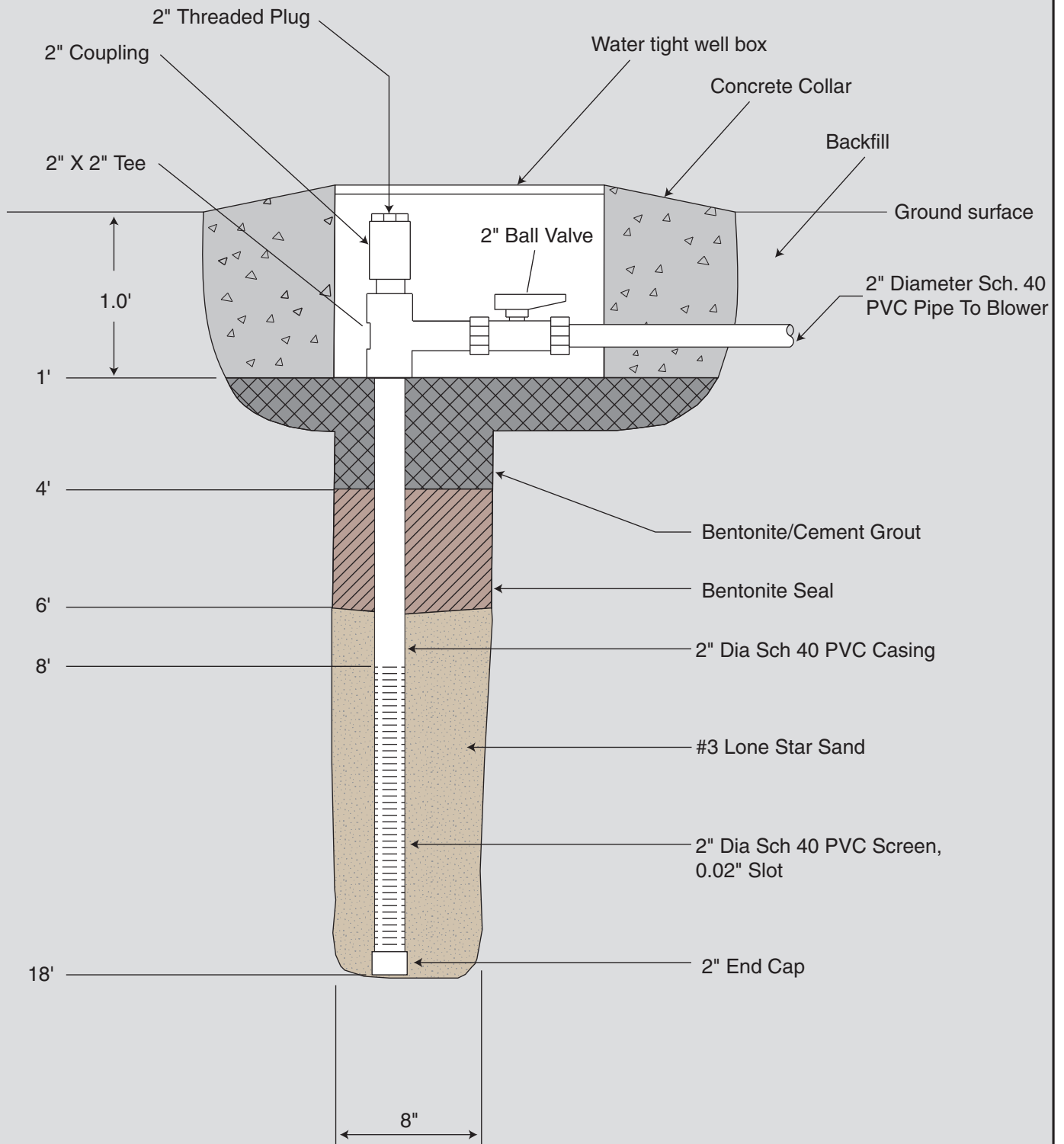

NOT TO SCALE
 (well casing is actually
 centered in borehole)

Note: All connections threaded
 with gasket or teflon tape.
 No glues used.

AS-BUILT VENT WELL CONSTRUCTION DETAILS FOR VW-2 & VW-3

Redwood Regional Park
 Oakland, CA

By: MJC

DECEMBER 2005

Figure 3



2005-66-09

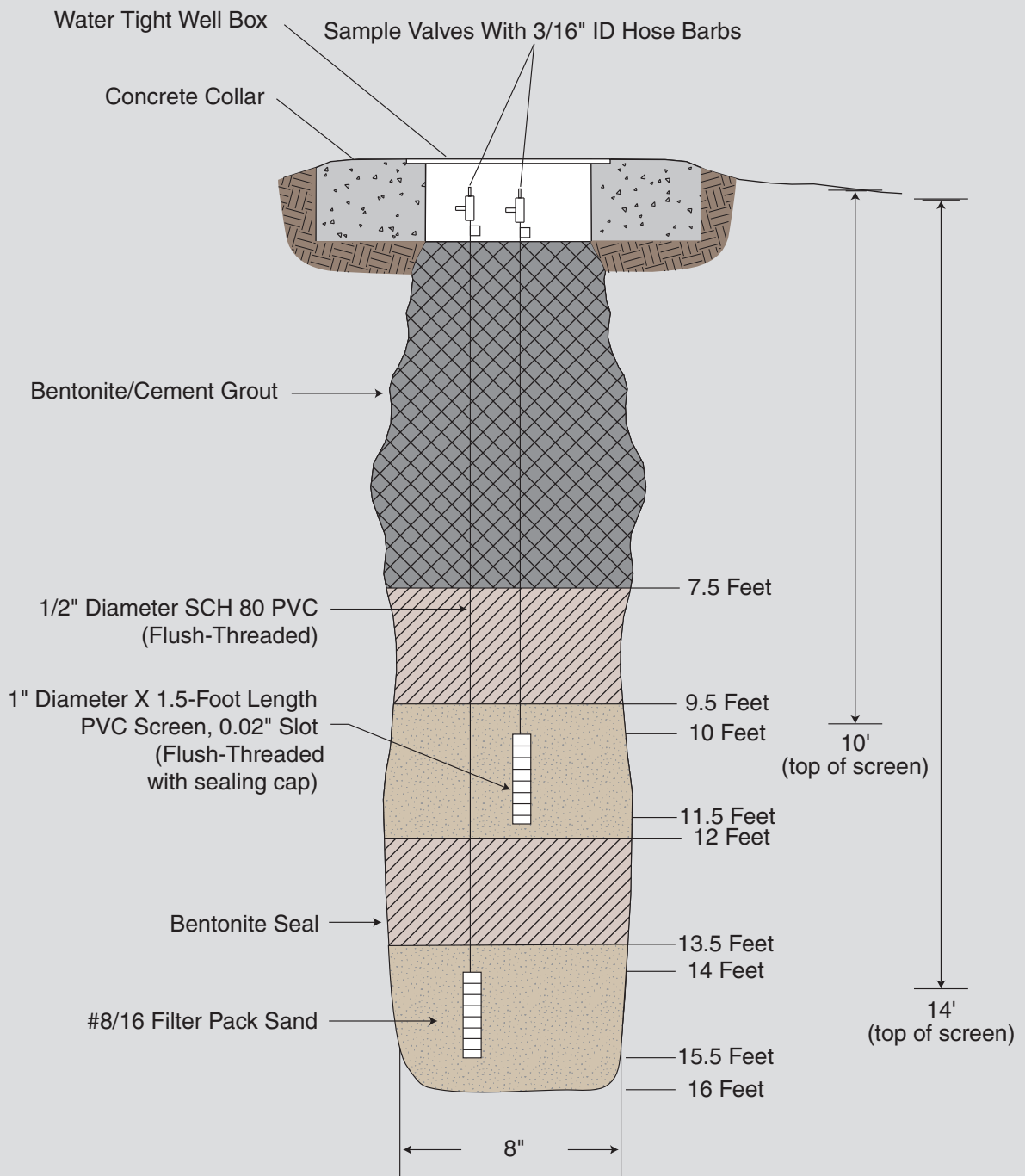

Not To Scale

Note: Depts shown are applicable to VMP-1 and VMP-2. Depth in VMP-3 and VMP-4 vary.

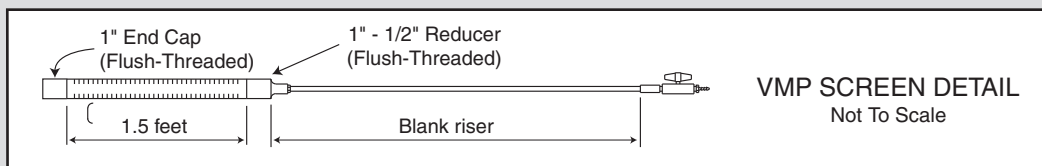

AS-BUILT VAPOR MONITORING POINT CONSTRUCTION DETAILS

Redwood Regional Park
Oakland, CA

By: MJC

JUNE 2005

Figure 4



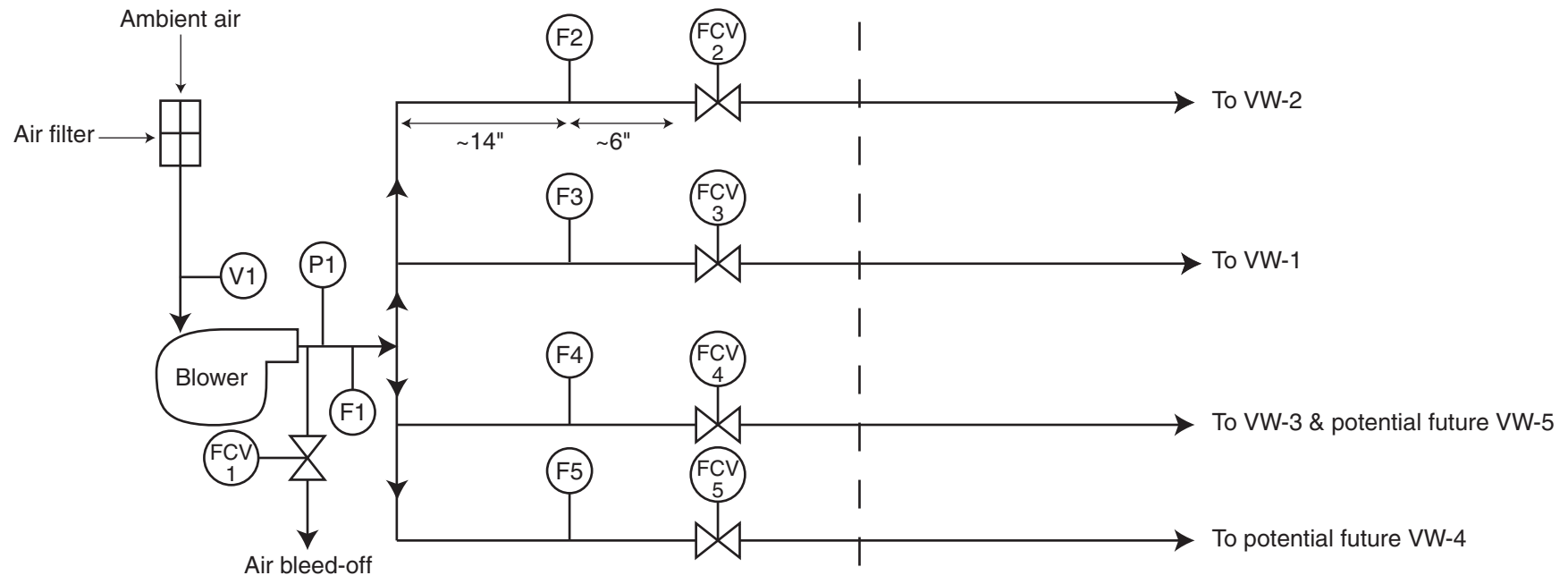

Blower/piping shed

LEGEND

- Pressure gauge
- Flow measurement port
- Vacuum gauge
- Flow control valve

2005-66-07



BIOVENTING PROCESS FLOW AND INSTRUMENTATION DIAGRAM
7867 Redwood Rd, Oakland, CA

Figure 5
by: MJC DECEMBER 2005

3.0 CURRENT QUARTER ACTIVITIES AND FINDINGS

SYSTEM OPERATION

As discussed in the bioventing system installation and startup report (SES, 2006a), the system was started up in January 2006, and four weekly monitoring/air flow optimization events were conducted. During that time, manifold valves were open to all three VWs; however, no measurable air injection occurred in VW-2 (fully flooded well screen) or VW-3 (partially flooded well screen). Blower outlet pressure during that period was set at 50 inches of water.

Following the January 24, 2006 (final) weekly event, all manifold valves were closed except for VW-3. The objective of this activity was to concentrate all air flow into VW-3, in an attempt to facilitate air injection into that well; however, the attempt was unsuccessful. On February 23, 2006, the manifold valves to all three VWs were re-opened. On February 27, 2006, the blower outlet pressure was reset to 40 inches of water. Following the March 2006 event, we closed the valve to VW-2 (as that screen has been fully flooded). Following the May 2006 event, we opened the valves to VW-2 (as well as VW-1 and VW-3). The system has operated continuously during the current quarter, except for temporary system shutdowns for monthly O&M activities.

O&M ACTIVITIES

Three monthly O&M events were conducted in the current quarter (on April 24, May 18, and June 19, 2006) with the following objectives:

- Confirm that the system was operating within design parameters, with no system problems (e.g., leaks, non-functioning components).
- Conduct preventive maintenance (i.e., clean blower air filter).
- Continue to evaluate if air was flowing through the screened intervals of VW-2 or VW-3.

Monthly O&M activities included:

- Measure water levels in all VMPs and VWs.
- Inspect aboveground portions of the system (i.e., blower, air distribution piping, and wellheads) for leaks or structural problems.
- Record blower outlet pressure and inlet vacuum.

- Qualitatively evaluate if air was flowing across the VW intervals. This was achieved by opening individual VW manifold wells while the blower was operating, and looking for a drop in blower pressure (a drop in outlet pressure when a valve is opened indicates that air flow is occurring).
- Inspect and clean the blower inlet filter.
- Repair one disconnected piping union, and tighten all aboveground piping clamps (in the April 2006 O&M event).
- Complete an O&M checklist.

During the May 2006 event, we measured air flow to each VW with an air velocity meter (thermal anemometer). We also bailed out flooded well VW-2 (which had a water level of 5.4 feet below grade, several feet above the top of the screen). We bailed the well down to 13.6 feet below grade. Water level approximately 12 hours later was 8.2 feet below grade, indicating that the high water level in this well is not due to water “trapped” since the spring rains.

Appendix A contains the completed checklists for the current quarter.

O&M FINDINGS

The results of the O&M activities are as follows:

- The blower is functioning properly, there are no significant air leaks in the piping system, and the VMP and VW wellheads and air distribution piping are in good condition.
- Water levels are approximately the same in shallow vs. deep VMPs (at each nested well location) suggesting that both the deep and shallow VMP well screens are under similar hydraulic conditions.
- Water levels in VWs showed a general increase after the wells were installed, resulting in partially or fully flooded well screens in all VWs. VW-1 and VW-3 showed a water level decrease through May 2006, and were slightly higher in June 2006. VW-2 showed an initial increase in water levels through March 2006, and has since shown a decrease. Figure 6 shows groundwater levels in VWs relative to the top of the well screened interval. The screen in VW-2 has been fully flooded since installation. Wells VW-1 and VW-3 have had partially exposed screens since installation.
- As shown on Figure 7, water levels in shallow VMPs showed a general increase (between 1.5 and 4.5 feet) between VMP installation and March 2006. Water levels have since begun to drop. As of May 2006, three of the four shallow VMP water levels were below the top of well screens.

- As shown on Figure 8, water levels in deep VMPs have been relatively stable since the VMPs were installed, with the exception of VMP-2-D, which has shown an increase since March 2006. Since the deep VMPs were installed, water levels in three of the four deep VMPs have been above the top of the well screen; only VMP-2-D has exposed well screen.
- Air is being injected (and has been since system startup) in the non-flooded portion of the VW-1 screen, but at flow rates less than optimum due to the partially flooded screen. A significant increase in apparent air flow in VW-1 was observed between the May and June 2006 events.
- No measurable air injection has occurred in VW-2 since system startup, due to the fully flooded screen. The June 2006 event was the first event in which the water level was below the top of well screen (approximately 0.5 feet).
- No measurable air injection has occurred in VW-3 since system startup, although that well's screen has been at least partially exposed (not flooded) since installation. SES confirmed (by physical probing) that the screened interval of that well is properly installed (from 8 to 18 feet), and water is infiltrating into the well (confirming that the annular filter pack was not inadvertently cemented in during well installation). The inability to inject air may be due to residual saturation in the well filter pack and/or surrounding soils, or because the native soils in the borehole annulus may have been smeared during installation.

**Figure 6 - Historical Groundwater Levels Relative to Top of VW Screened Intervals
Redwood Regional Park Service Yard - Oakland, California**

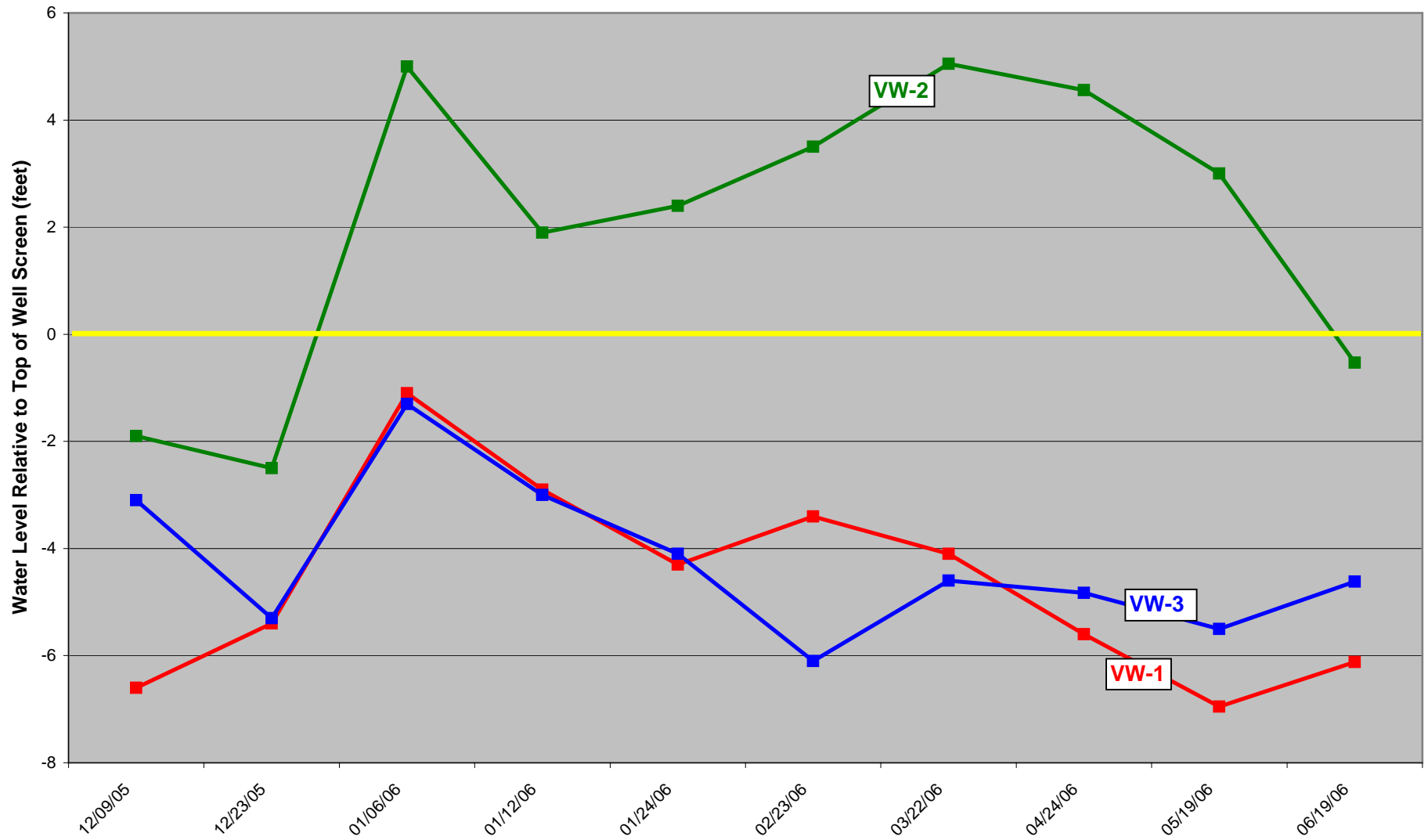

Note: "0" line represents the top of well screened interval;
water levels above that line represent fully flooded screen.

**Figure 7 - Historical Groundwater Levels Relative to Top of Shallow VMP Screened Intervals
Redwood Regional Park Service Yard - Oakland, California**

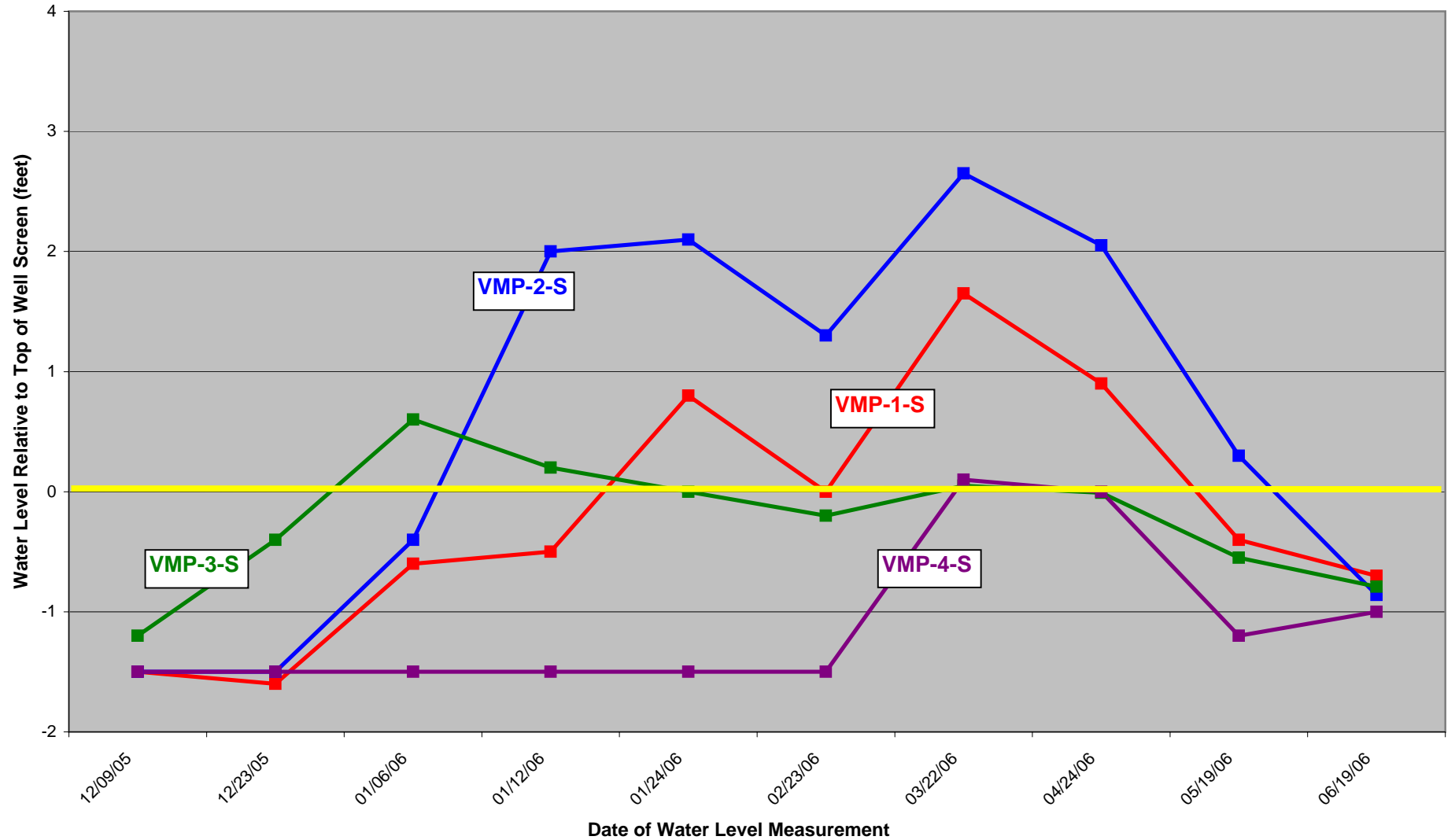

Note: "0" line represents the top of well screened interval;
water levels above that line represent fully flooded screen.

**Figure 8 - Historical Groundwater Levels Relative to Top of Deep VMP Screened Intervals
Redwood Regional Park Service Yard - Oakland, California**

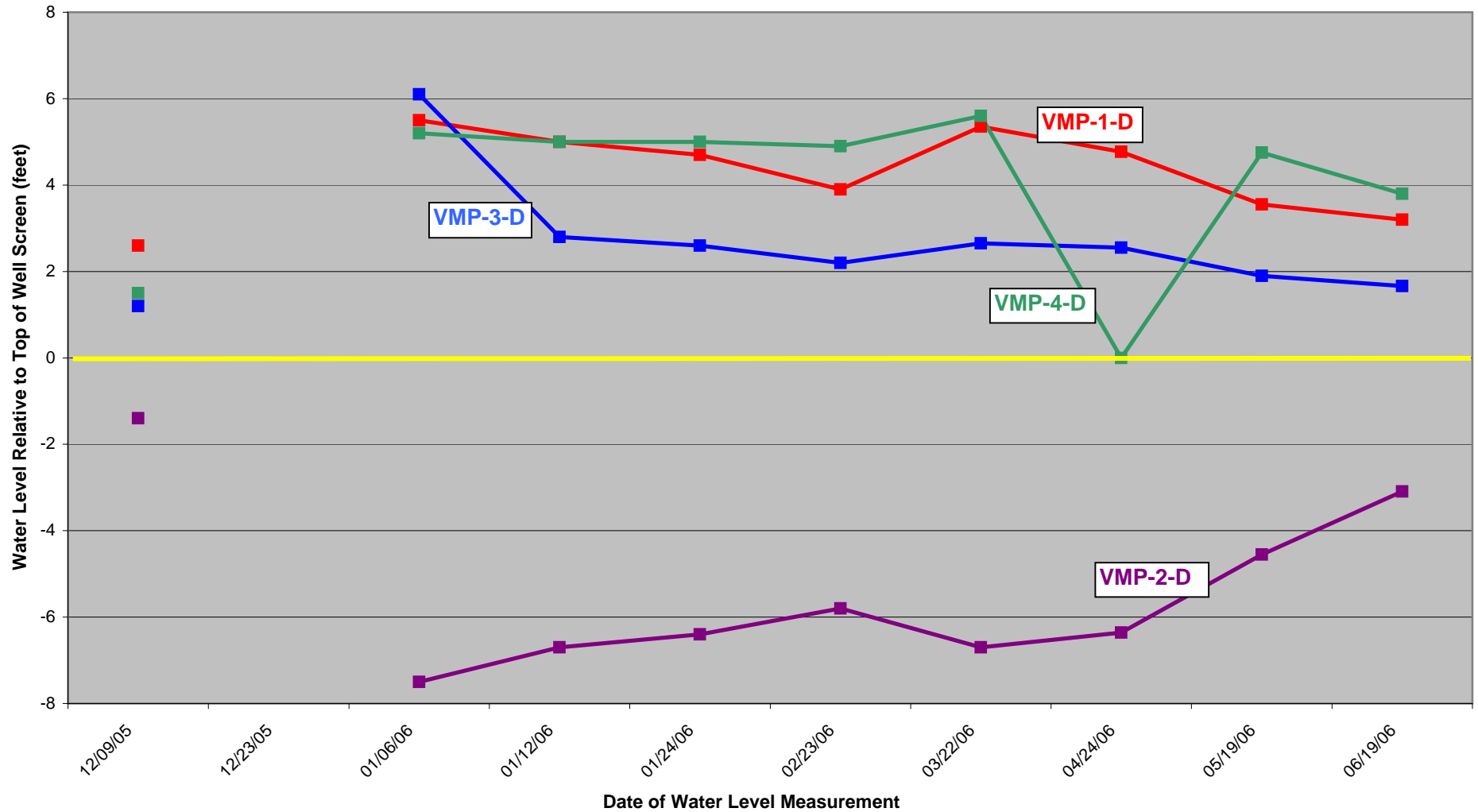

Note: "0" line represents the top of well screened interval; water levels above that line represent fully flooded screen.

4.0 SUMMARY, CONCLUSIONS, AND PROPOSED ACTIONS

This section presents the conclusions and proposed actions with regard to continued operation of the bioventing corrective action system at the Redwood Regional Park Service Yard.

SUMMARY AND CONCLUSIONS

- The unusually high rainfall in 2006 has resulted in the bioventing wells remaining particularly or fully saturated; thus, no air flow is reaching the sediments at this time.
- The blower is operating within design parameters, and there are no physical problems with the blower or air distribution piping.
- Air flow is occurring through a small portion of the VW-1 screened interval, but at a less-than-optimum rate due to high water level conditions.
- No air flow is occurring through the VW-2 screened interval due to the saturated well screen interval.
- No air flow is occurring through the VW-3 screened interval; a portion of the well screen is below the water level, and the capillary fringe likely is still saturated. The reason for the lack of air flow in this VW is still being explored; this well will be monitored closely as water levels drop throughout the summer and fall. An air injection test (conducted at 1 order of magnitude greater pressure than that delivered by the blower) indicated that air is leaking from the well, likely through fittings below grade and near the surface.
- Continued monthly O&M (including water level measurements) will determine whether air injection rates at the VWs improve.

PROPOSED ACTIONS

EBRPD proposes to implement the following actions with regard to the bioventing program:

- Continue to conduct monthly system O&M events, including air flow optimization when water level changes and/or air injection rates warrant.
- Continue to evaluate water levels in VWs and VMPs.

- Conduct an in situ respiration, including air permeability and system radius of influence, at such time as water levels drop sufficiently to evaluate response in at least the shallow VMP screens.
- Continue to report on bioventing system progress/activities in quarterly progress reports, and prepare an annual summary report (approximately 1 year after the system began operation).
- If future O&M events demonstrate continued absence of air flow through the VW-2 well screen, additional troubleshooting and/or corrective action will be evaluated.

5.0 REFERENCES

- Alameda County Health Care Services Agency, Department of Environmental Health (Alameda County Environmental Health), 2006. Letter approving monthly bioventing O&M and reporting and in-situ respiration test. March 15.
- Alameda County Health Care Services Agency, Department of Environmental Health (Alameda County Environmental Health), 2005a. Letter regarding Alameda County Health's review of SES Bioventing Pilot Test Report. May 25.
- Alameda County Health Care Services Agency, Department of Environmental Health (Alameda County Environmental Health), 2005b. Letter approving installation and implementation of bioventing full-scale system. June 24.
- Stellar Environmental Solutions, Inc. (SES), 2006a. Bioventing System Installation and Startup Report - Redwood Regional Park Service Yard, Oakland, California. February 21.
- Stellar Environmental Solutions, Inc. (SES), 2006b. First Quarter 2006 Bioventing Status Report – Redwood Regional Park Service Yard, Oakland, California. April 3.
- Stellar Environmental Solutions, Inc. (SES), 2004a. Bioventing Feasibility Letter Report – Redwood Regional Park Service Yard, Oakland, California. February 6.
- Stellar Environmental Solutions, Inc. (SES), 2004b. Bioventing Pilot Tests Result Report, Redwood Regional Park Service Yard, Oakland, California. October 29.
- Stellar Environmental Solutions, Inc. (SES), 2003. Letter to Alameda County Health Care Services Agency proposing bioventing as a corrective action remedy at Redwood Regional Park Service Yard, Oakland, California. November 6.

APPENDIX A

Monthly System O&M Checklists

**Redwood Regional Park Service Yard
Bioventing Operation & Maintenance Checklist
Blower and Vent Wells**

Date: 4/24/06

	Air Flow (scfm)		Blower Inlet Vacuum (inches H ₂ O)		Blower Outlet Pressure (inches H ₂ O)		Depth to Top of Screen (ft below TOC)	Water Level (ft below TOC)	Well Head in Good Condition?
	Before adjustment	After adjustment	Before adjustment	After adjustment	Before adjustment	After adjustment			
Blower ^(a)	NM	NM	18	18	38	40 ^(c)			
VW-1 ^(b)	NM	NM					5.6	11.20	yes
VW-2 ^(b)	NM	NM					8.4	3.84	yes
VW-3 ^(b)	NM	NM					8.8	13.63	yes

Wells on-line (valve open) at arrival VW-1, -2 & -3 Wells on-line at departure VW-1, -2 & -3

Notes:

- ^(a) Air flow measured at sampling port between blower discharge and manifold.
 - ^(b) Air flow measured at blower manifold sampling port
 - ^(c) Blower outlet pressure re-set to 40 inches H₂O on 4/25/06 following piping repairs.
- TOC - Top of Casing of well NM = Not Measured

Checklist Items

Is any airflow evident through VW-1? 6 inches H₂O drop
(Close all VW valves, set outlet pressure at 40 inches H₂O, then open VW-1 valve only)

Is any airflow evident through VW-2? 0 inches H₂O drop
(Close all VW valves, set outlet pressure at 40 inches H₂O, then open VW-2 valve only)

Is any airflow evident through VW-3? 0 inches H₂O drop
(Close all VW valves, set outlet pressure at 40 inches H₂O, then open VW-3 valve only)

Any audible air leaks in air distribution piping or VW wellheads? Yes. Slight leak in piping repaired 4/25/06

Blower filter removed and brushed off? Yes Blower filter replaced? No

**Redwood Regional Park Service Yard
Bioventing Operations & Maintenance Checklist
Vapor Monitoring Points**

Date: 4/24/06

	Depth to Top of Screen (ft below TOC)	Water Level (ft below TOC)	Well Head in Good Condition?
VMP-1-Shallow	9.3	8.40	Yes
VMP-1-Deep	13.4	8.63	Yes
VMP-2-Shallow	9.5	7.45	Yes
VMP-2-Deep	13.9	7.54	Yes
VMP-3-Shallow	9.8	9.81	Yes
VMP-3-Deep	12.0	9.45	Yes
VMP-4-Shallow	15.1	Dry	Yes
VMP-4-Deep	20.8	Dry	Yes

TOC= Top of well Casing

**Redwood Regional Park Service Yard
Bioventing Operation & Maintenance Checklist
Blower and Vent Wells**

Date: 5/18/06 & 5/19/06

	Air Flow (scfm)		Blower Inlet Vacuum (inches H ₂ O)		Blower Outlet Pressure (inches H ₂ O)		Depth to Top of Screen (ft below TOC)	Water Level (ft below TOC)	Well Head in Good Condition?
	Before adjustment	After adjustment	Before adjustment	After adjustment	Before adjustment	After adjustment			
Blower ^(a)	NM	16.9	18	18	36	40			
VW-1 ^(b)	NM	16					5.6	12.55	yes
VW-2 ^(b)	NM	< 1					8.4	5.40	yes
VW-3 ^(b)	NM	< 1					8.8	14.30	yes

Wells on-line (valve open) at arrival

VW-1 & VW-3

Wells on-line at departure

VW-1, -2 -3

Notes:

^(a) Air flow measured at sampling port between blower discharge and manifold.

^(b) Air flow measured at blower manifold sampling port

TOC - Top of Casing of well

NM = Not Measured

Checklist Items

Is any airflow evident through VW-1?

(Close all VW valves, set outlet pressure at 40 inches H₂O, then open VW-1 valve only)

8 inches H₂O drop

Is any airflow evident through VW-2?

(Close all VW valves, set outlet pressure at 40 inches H₂O, then open VW-2 valve only)

0 inches H₂O drop

Is any airflow evident through VW-3?

(Close all VW valves, set outlet pressure at 40 inches H₂O, then open VW-3 valve only)

0 inches H₂O drop

Any audible air leaks in air distribution piping or VW wellheads?

no

Blower filter removed and brushed off?

yes

Blower filter replaced?

no

**Redwood Regional Park Service Yard
Bioventing Operations & Maintenance Checklist
Vapor Monitoring Points**

Date: 5/18/06

	Depth to Top of Screen (ft below TOC)	Water Level (ft below TOC)	Well Head in Good Condition?
VMP-1-Shallow	9.3	9.70	Yes
VMP-1-Deep	13.4	9.85	Yes
VMP-2-Shallow	9.5	9.20	Yes
VMP-2-Deep	13.9	9.35	Yes
VMP-3-Shallow	9.8	10.35	Yes
VMP-3-Deep	12.0	10.10	Yes
VMP-4-Shallow	15.1	16.30	Yes
VMP-4-Deep	20.8	16.05	Yes

TOC= Top of well Casing

**Redwood Regional Park Service Yard
Bioventing Operation & Maintenance Checklist
Blower and Vent Wells**

Date: 6/19/06

	Air Flow (scfm)		Blower Inlet Vacuum (inches H ₂ O)		Blower Outlet Pressure (inches H ₂ O)		Depth to Top of Screen (ft below TOC)	Water Level (ft below TOC)	Well Head in Good Condition?
	Before adjustment	After adjustment	Before adjustment	After adjustment	Before adjustment	After adjustment			
Blower ^(a)	NM	NM	22	18	22	40			
VW-1 ^(b)	NM	NM					5.6	11.72	yes
VW-2 ^(b)	NM	NM					8.4	8.93	yes
VW-3 ^(b)	NM	NM					8.8	13.42	yes

Wells on-line (valve open) at arrival VW-1, -2 & -3 Wells on-line at departure VW-1, -2 & -3

Notes:

^(a) Air flow measured at sampling port between blower discharge and manifold.

^(b) Air flow measured at blower manifold sampling port

TOC - Top of Casing of well NM = Not Measured

Checklist Items

Is any airflow evident through VW-1? 38 inches H₂O drop
(Close all VW valves, set outlet pressure at 40 inches H₂O, then open VW-1 valve only)

Is any airflow evident through VW-2? 0 inches H₂O drop
(Close all VW valves, set outlet pressure at 40 inches H₂O, then open VW-2 valve only)

Is any airflow evident through VW-3? 0 inches H₂O drop
(Close all VW valves, set outlet pressure at 40 inches H₂O, then open VW-3 valve only)

Any audible air leaks in air distribution piping or VW wellheads? no

Blower filter removed and brushed off? yes Blower filter replaced? no

**Redwood Regional Park Service Yard
Bioventing Operations & Maintenance Checklist
Vapor Monitoring Points**

Date: 6/19/06

	Depth to Top of Screen (ft below TOC)	Water Level (ft below TOC)	Well Head in Good Condition?
VMP-1-Shallow	9.3	10.00	Yes
VMP-1-Deep	13.4	10.20	Yes
VMP-2-Shallow	9.5	10.36	Yes
VMP-2-Deep	13.9	10.81	Yes
VMP-3-Shallow	9.8	10.59	Yes
VMP-3-Deep	12.0	10.34	Yes
VMP-4-Shallow	15.1	16.10	Yes
VMP-4-Deep	20.8	17.00	Yes

TOC= Top of well Casing