

**RECEIVED**

2:20 pm, Jan 20, 2009

Alameda County  
Environmental Health

# **Q3/Q4 2008 BIOVENTING STATUS AND ANNUAL SUMMARY REPORT**

**REDWOOD REGIONAL PARK  
SERVICE YARD  
OAKLAND, CALIFORNIA**

*Prepared for:*

**EAST BAY REGIONAL PARK DISTRICT  
OAKLAND, CALIFORNIA**

**January 2009**

# **Q3/Q4 2008 BIOVENTING STATUS AND ANNUAL SUMMARY REPORT**

**REDWOOD REGIONAL PARK  
SERVICE YARD  
OAKLAND, CALIFORNIA**

*Prepared for:*

**EAST BAY REGIONAL PARK DISTRICT  
P.O. BOX 5381  
OAKLAND, CALIFORNIA 94605**

*Prepared by:*

**STELLAR ENVIRONMENTAL SOLUTIONS  
2198 SIXTH STREET, SUITE 201  
BERKELEY, CALIFORNIA 94710**

**January 15, 2009**

Project No. 2006-17

January 15, 2009

Mr. Jerry Wickham, P.G.  
Hazardous Materials Specialist  
Alameda County Department of Environmental Health  
1131 Harbor Bay Parkway, Suite 250  
Alameda, California 94502

Subject: Third and Fourth Quarters 2008 Bioventing Status and Annual Summary Report,  
Redwood Regional Park Service Yard Site, Oakland, California – RO #0000246

Dear Mr. Wickham:

This report discusses activities conducted during the third and fourth quarters of 2008, and summarizes activities related to a bioventing corrective action system at the Redwood Regional Park Service Yard, located at 7867 Redwood Road, Oakland, California. A microbial respiration test was conducted during this period, from October 13 to October 15, 2008. This project is being conducted for the East Bay Regional Park District, and follows previous site investigation and remediation activities (conducted since 1993). The key regulatory agencies for this investigation are the Alameda County Department of Environmental Health, the Regional Water Quality Control Board, and the California Department of Fish and Game. I declare, under penalty of perjury, that the information and/or recommendations contained in the attached document or report is true and correct to the best of my knowledge.

If you have any questions regarding this report, please contact Mr. Neal Fujita of the East Bay Regional Park District, or contact me directly at (510) 644-3123.

Sincerely,



Richard S. Makdisi, R.G., R.E.A.  
Principal and Project Manager

cc: Carl Wilcox - California Department of Fish and Game  
Neal Fujita - East Bay Regional Park District  
State of California GeoTracker system (electronic upload)



# TABLE OF CONTENTS

---

Section	Page
1.0 PROJECT DESCRIPTION AND SITE HISTORY.....	1
Project Description.....	1
Site Description.....	1
Site History and Contamination.....	4
Regulatory Status and Data Reporting.....	5
2.0 BIOVENTING SYSTEM DESCRIPTION .....	6
3.0 THIRD AND FOURTH QUARTERS ACTIVITIES AND FINDINGS.....	11
System Operation.....	11
O&M Activities.....	11
O&M Findings .....	12
In-Situ Respiration Test .....	16
Respiration Test .....	16
4.0 SUMMARY, CONCLUSIONS, AND PROPOSED ACTIONS.....	20
Summary and Conclusions.....	20
Proposed Actions .....	20
5.0 REFERENCES.....	21

## Appendices

Appendix A Monthly System O&M Checklists

# TABLES AND FIGURES

---

<b>Tables</b>	<b>Page</b>
Table 1 Bioventing Well Construction Data Redwood Regional Park Service Yard, Oakland, California.....	7

<b>Figure</b>	<b>Page</b>
Figure 1 Site Location on USGS Topographic Map .....	2
Figure 2 Full Scale Bioventing System Site Plan.....	3
Figure 3 As-Built Vent Well Construction Details .....	8
Figure 4 As-Built Vapor Monitoring Point Construction Details .....	9
Figure 5 Bioventing Process Flow and Instrumentation Diagram .....	10
Figure 6 Historical Groundwater Levels Relative to Top of Bioventing Well Screened Intervals .....	13
Figure 7 Historical Groundwater Levels Relative to Top of Shallow Vapor Monitoring Point Screened Intervals .....	14
Figure 8 Historical Groundwater Levels Relative to Top of Deep Vapor Monitoring Point Screened Intervals .....	15
Figure 9 Respiration Plot Data .....	18

## **1.0 PROJECT DESCRIPTION AND SITE HISTORY**

---

### **PROJECT DESCRIPTION**

The subject property is the East Bay Regional Park District (EBRPD) Redwood Regional Park Service Yard, located at 7867 Redwood Road in Oakland, Alameda County, California. The site has undergone site investigations and remediation since 1993 to address subsurface contamination caused by leakage from one or both of two former underground fuel storage tanks (UFSTs) that contained gasoline and diesel fuel. The Alameda County Department of Environmental Health (ACEH) has provided regulatory oversight of the investigation since its inception. Other regulatory agencies with historical involvement in site review include the Regional Water Quality Control Board – San Francisco Bay Region (Water Board) and the California Department of Fish and Game (CDFG).

Bioventing was selected as an appropriate corrective action to mitigate residual petroleum contamination, based on site conditions, residual contaminant distribution, and results from a previously conducted bioventing pilot test in 2004 (SES, 2004b). The bioventing system was approved by ACEH (ACEH, 2005b), and was installed and started up in December 2005 and January 2006 (SES, 2006a). The First Quarter Bioventing Status Report was issued in April 2006 (SES, 2006b). ACEH responded to that report (in its letter of March 15, 2006) approving the proposed approach of monthly bioventing operations and maintenance (O&M) and reporting.

This report documents the activities conducted in the third and fourth quarter of 2008, and summarizes the soil bioventing system-related activities conducted at the site throughout 2008. A microbial respiration test was conducted during the fourth quarter, from October 13 to October 15, 2008.

### **SITE DESCRIPTION**

Figure 1 presents the project site location. A site plan showing the full-scale bioventing system is provided on Figure 2.





3-D TopoQuads Copyright © 1999 DeLorme Yarmouth, ME 04096 Source Data: USGS 750 ft Scale: 1 : 25,000 Detail: 13-0 Datum: WGS84



### SITE LOCATION ON U.S.G.S. TOPOGRAPHIC MAP

Redwood Reg. Park Service Yard  
Oakland, CA

By: MJC

MARCH 2006

Figure 1



2006-17-01



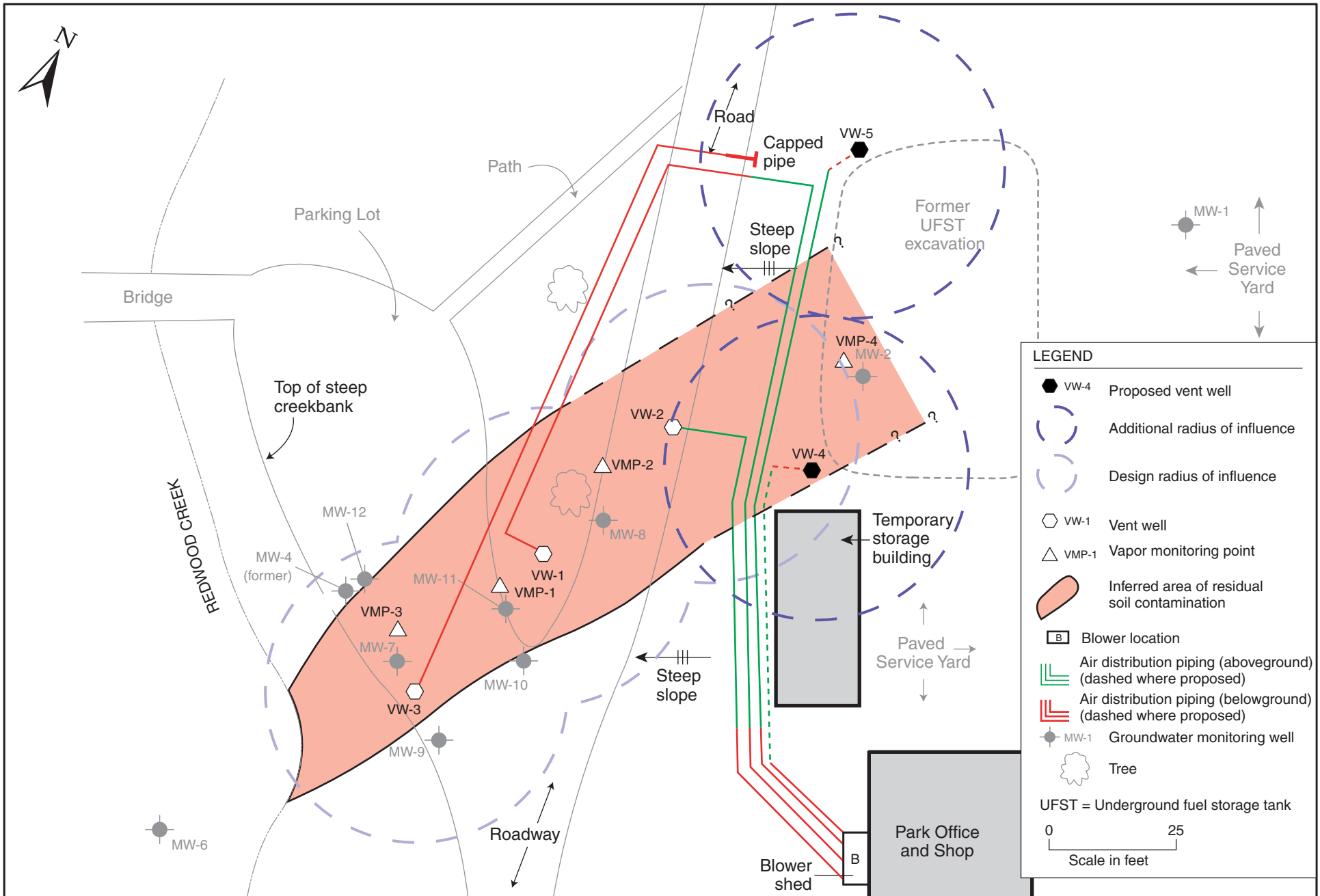

**PROPOSED BIOVENTING SYSTEM AUGMENTATION**  
**7867 Redwood Rd, Oakland, CA**

**Figure 1**

by: MJC

FEBRUARY 2008



The site slopes to the west, from an elevation of approximately 564 feet above mean sea level (amsl) at the eastern edge of the service yard to approximately 530 feet amsl at Redwood Creek, which defines the approximate western edge of the project site with regard to this investigation.

From east to west, the study area consists of:

- Flat, paved EBRPD service yard with several permanent and temporary buildings/sheds (former UFST excavation area)
- Steep slope (approximately 45 degrees) between the western edge of the service yard and the park entrance road (immediately west of MW-2)
- Hummocky terrain with low vegetation (between MW-8 and MW-11), including a large EBRPD-designated sycamore tree (adjacent to MW-8 and VMP-2)
- Flat, unpaved parking lot (between MW-11 and MW-7)
- Steep slope (approximately 45 degrees) to Redwood Creek (immediately west of MW-12, MW-7, and MW-9)

## **SITE HISTORY AND CONTAMINATION**

Contaminant corrective actions and investigations have been conducted at the site since 1993. General phases of work previously conducted include:

- Removal of UFSTs and contaminated soil
- Installation and quarterly monitoring of groundwater monitoring wells
- Several phases of remedial investigation-oriented exploratory borehole drilling and sampling
- A correction action feasibility study
- Two phases of Oxygen Releasing Compound (ORC™) injection
- An evaluation of bioventing feasibility as a corrective action, which included a bioventing pilot test
- Installation and startup of the bioventing system in December 2005 and January 2006 (after startup, four weekly monitoring/air flow optimization events were conducted)
- Installation of two additional bioventing vent wells (VW-4 and VW-5) in the source area and disconnection of VW-3

As detailed in previous SES reports, the available data support the following conclusions:

- The saturated zone overlies laterally extensive bedrock, which limits downward migration of groundwater contamination.
- The unsaturated zone varies in thickness due to seasonal water level fluctuations of several feet.
- Site chemicals of concern include total petroleum hydrocarbons (TPH)—specifically as gasoline (TPHg) and diesel (TPHd); benzene, toluene, ethylbenzene, and xylenes (BTEX); and methyl *tertiary*-butyl ether (MTBE).
- Residual soil contaminant mass in the unsaturated zone is acting as a long-term source of groundwater contamination; the maximum thickness of the residual soil contamination (during lowest water level periods) is approximately 10 feet.
- Previous ORC™ injection programs resulted in apparent permanent reductions at the peripheral plume margins, but were followed by rebound to pre-injection conditions within the central portions of the plume, corroborating the conceptual model that remaining unsaturated zone soil contamination is continuing to impact groundwater.
- Site conditions appear favorable for bioventing as a corrective action to reduce unsaturated zone soil contamination, especially in the near-source area that is inaccessible to other methods due to the hilly topography.

## **REGULATORY STATUS AND DATA REPORTING**

The lead regulatory agency for the site investigation and remediation is ACEH, with oversight provided by the Water Board. The CDFG is also involved with regard to water quality impacts to Redwood Creek. Installation and startup of the full-scale bioventing system was approved in 2005, and implementation of the monthly bioventing O&M program with a yearly in-situ respiration test began in 2006 (ACEH, 2005b; ACEH, 2006). The most recent regulatory agency input was ACEH's approval to augment the existing bioventing system with two additional vent wells (VW-4 and VW-5) in the source area and the disconnection of VW-3 (ACEH, 2008).

The site is in compliance with the State Water Resources Control Board's GeoTracker requirements for uploading of electronic data and reports. In addition, electronic copies of all bioventing-related reports have been uploaded to the ACEH online file transfer protocol (ftp) system. Per ACEH's October 31, 2005 "Miscellaneous Administrative Topics and Procedures" directive, effective January 31, 2006, paper copies of reports are no longer required to be provided to ACEH.

## 2.0 BIOVENTING SYSTEM DESCRIPTION

---

The bioventing system consists of the following components:

- Four vent wells (VWs)—VW-1, VW-2, VW-4, and VW-5—screened across both the saturated and unsaturated zones.
- Four vapor monitoring points (VMPs), each with two nested screened intervals at depths coincident with VW screened intervals.
- A regenerative-type air blower installed in a small shed on the west side of the service yard garage building. The blower is rated at 140 cubic feet per minute (cfm) and exerts a pressure of approximately 1 to 3 pounds per square inch (psi).
- Air distribution piping between the blower and the VW wellheads, including a manifold just downstream of the blower.
- Appurtenant air flow valves, pressure/vacuum gauges, and air sampling ports.

Table 1 summarizes bioventing well construction data. Figure 2 (in the previous chapter) is a site plan showing the layout of the bioventing system. Figures 3 and 4 are as-builts for typical site VMPs and VWs, respectively. Figure 5 is a flow instrumentation diagram for the blower and associated manifold. This blower system was designed and configured based on the pilot test design specifications—i.e., achieving a potential 30-foot radius of influence and a flow rate of 40 standard cubic foot per minute (scfm) to individual VWs under induced pressure conditions.

**Table 1**  
**Bioventing Well Construction Data**  
**Redwood Regional Park Service Yard, Oakland, California**

Well	Screen Interval Depth (feet)	Filter Pack Sand Depth Interval (feet)
VW-1	6 – 16	4 – 16
VW-2	8 – 18	6 – 18
VW-3 <sup>(a)</sup>	8 – 18	6 – 18
VW-4	15 – 27	14.5 – 27
VW-5	13 – 26	12.5 – 26
VMP-1	10 – 11.5	9.5 – 12
	14 – 15.5	13.5 – 16
VMP-2	10 – 11.5	9.5 – 12
	14 – 15.5	13.5 – 16
VMP-3	10 – 11.5	9.5 – 12
	12.5 – 14	12 – 14.5
VMP-4	15.5 – 17	15 – 17.5
	20.5 – 22	20 – 20.5

Notes:

<sup>(a)</sup> disconnected

All depths are in feet below top of well box (approximately ground surface).



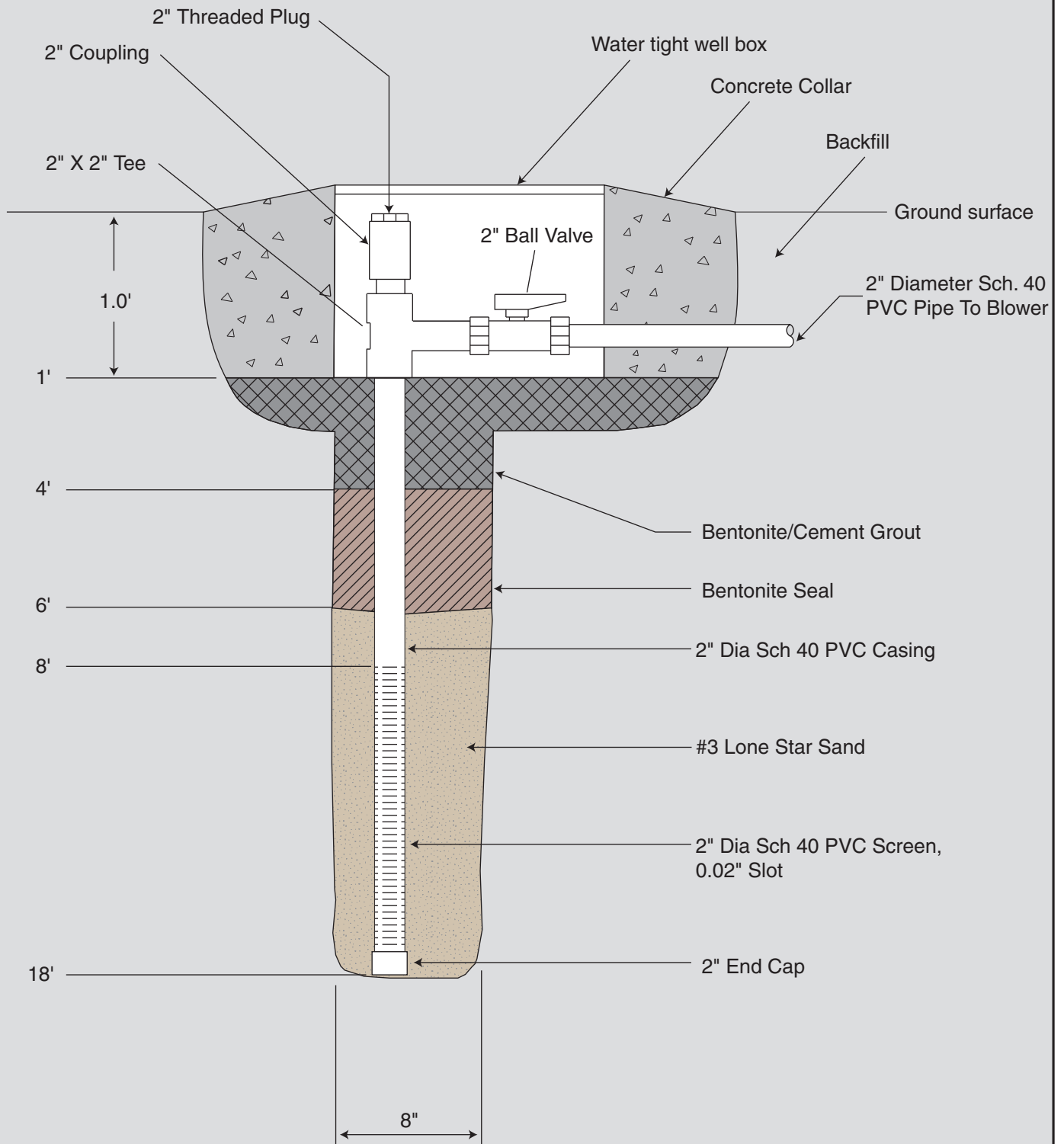

Note: All connections threaded with gasket or teflon tape. No glues used.

**AS-BUILT VENT WELL CONSTRUCTION DETAILS FOR VW-2 & VW-3**

Redwood Regional Park  
Oakland, CA

By: MJC

DECEMBER 2005

**Figure 3**



2005-66-09

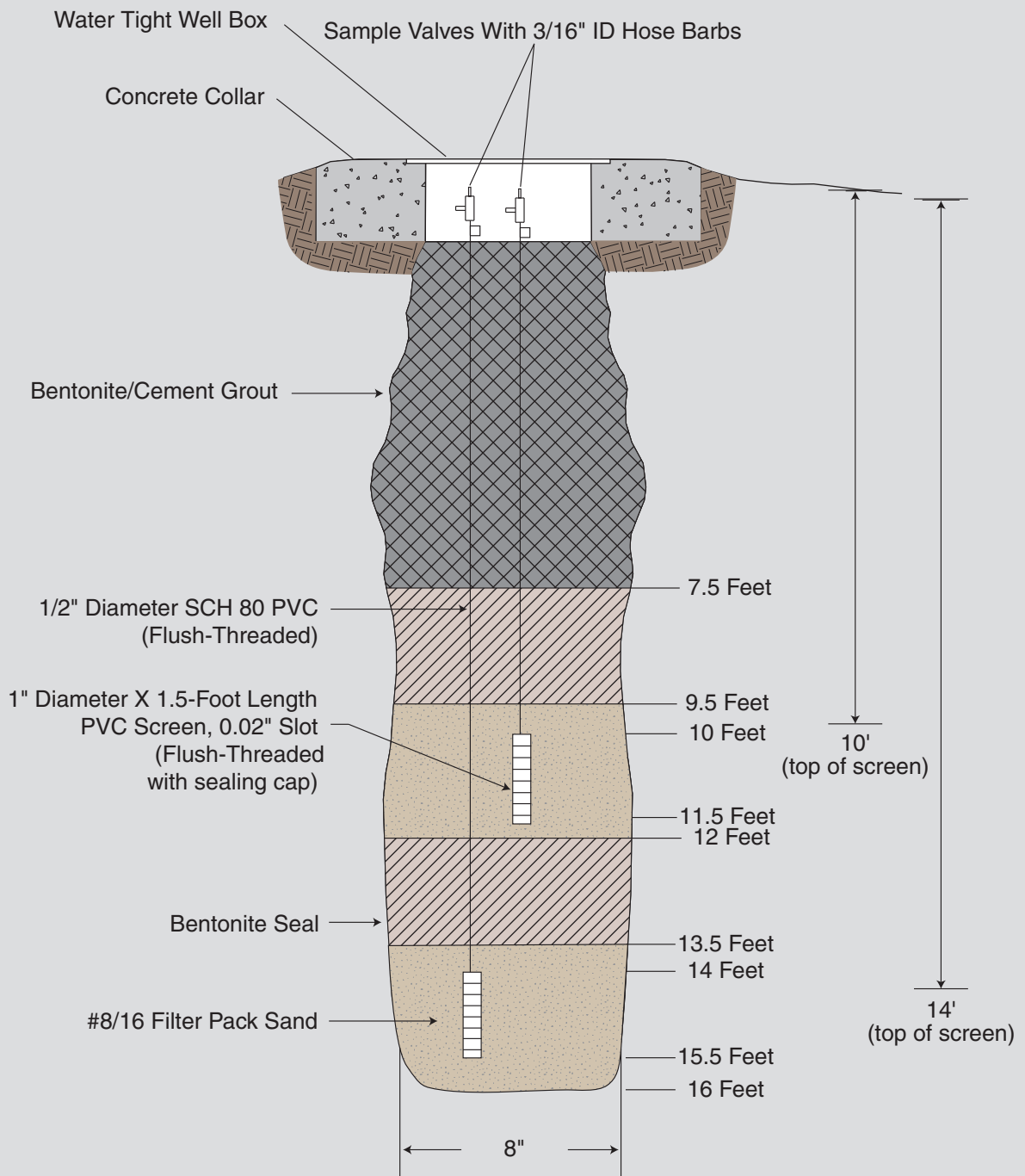

Not To Scale

Note: Depts shown are applicable to VMP-1 and VMP-2. Depts in VMP-3 and VMP-4 vary.

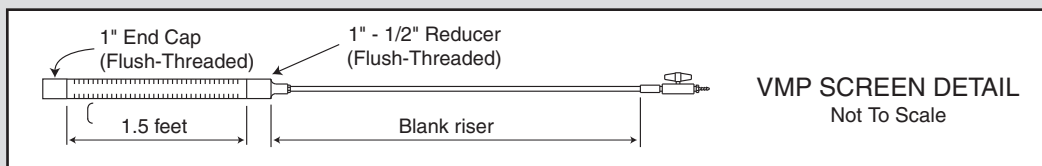

VMP SCREEN DETAIL  
Not To Scale

**AS-BUILT VAPOR MONITORING POINT CONSTRUCTION DETAILS**

Redwood Regional Park  
Oakland, CA

By: MJC

JUNE 2005

**Figure 4**



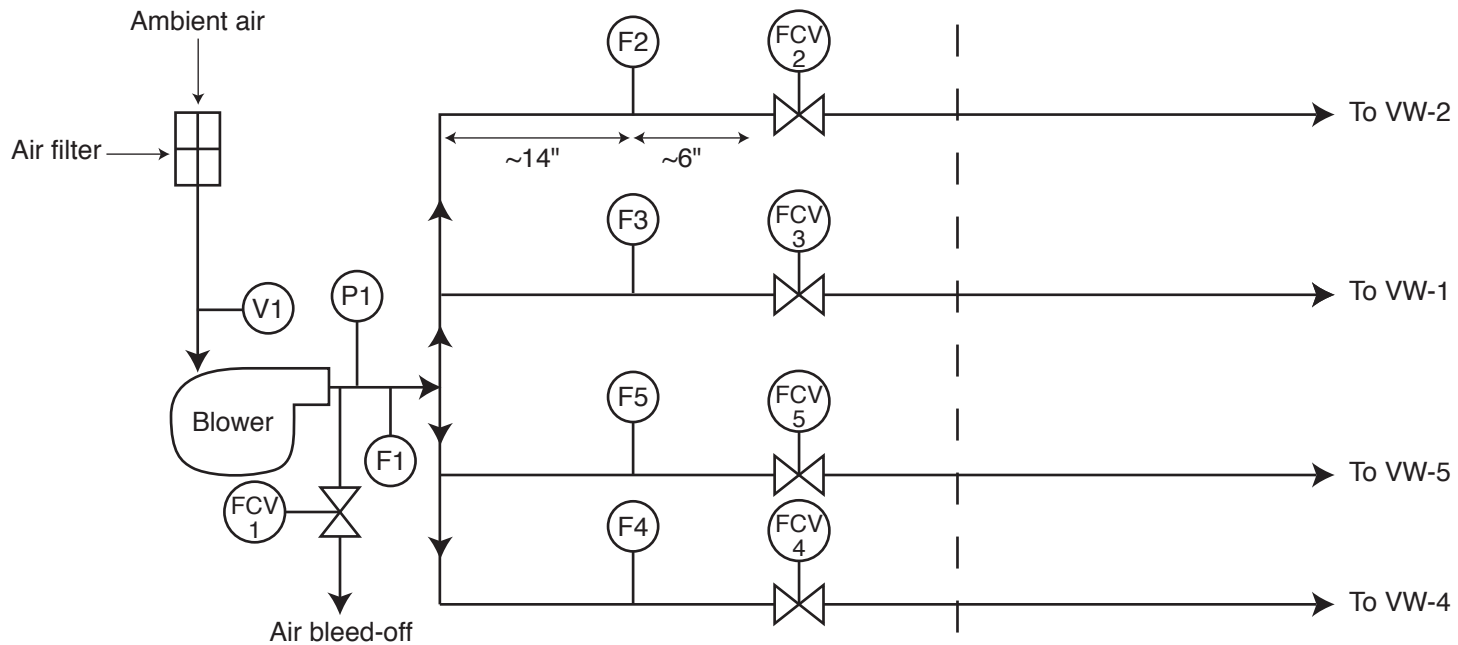

**LEGEND**

- Pressure gauge
- Flow measurement port
- Vacuum gauge
- Flow control valve

2005-66-17

### **3.0 THIRD AND FOURTH QUARTERS ACTIVITIES AND FINDINGS**

---

#### **SYSTEM OPERATION**

As discussed in the bioventing system installation and startup report (SES, 2006a), the system was started up in January 2006, and four weekly monitoring/air flow optimization events were conducted. During that time, manifold valves were open to all three VWs; however, no measurable air injection occurred in VW-2 (fully flooded well screen) or VW-3 (partially flooded well screen). Blower outlet pressure during that period was set at 50 inches of water.

Since January 2007, the system has operated continuously with VW-1, VW-2, and VW-3 fully open, except for temporary system shutdowns for monthly O&M activities. However, even after continuous monitoring and well flushing, no noticeable air flow occurred through VW-3. VW-3 was turned off, and vent wells VW-4 and VW-5 were installed in March 2008.

#### **O&M ACTIVITIES**

Monthly O&M events were conducted during the third and fourth quarters (on July 7, August 14, September 18, October 13, December 2, and December 17, 2008), with the following objectives:

- Confirm that the system was operating within design parameters, with no system problems (e.g., leaks, non-functioning components).
- Conduct preventive maintenance (i.e., clean blower air filter).
- Continue to evaluate air flow through the VW screened intervals.

Monthly O&M activities included:

- Measure water levels in all VMPs and VWs.
- Inspect aboveground portions of the system (i.e., blower, air distribution piping, and wellheads) for leaks or structural problems.
- Record blower outlet pressure and inlet vacuum.



- Qualitatively evaluate if air was flowing across the VW intervals. This was achieved by opening individual VW manifold wells while the blower was operating, and looking for a drop in blower pressure (a drop in outlet pressure when a valve is opened indicates that air flow is occurring).
- Inspect and clean the blower inlet filter.
- Complete an O&M checklist.

Appendix A contains the completed checklists for the third and fourth quarters.

## **O&M FINDINGS**

The results of the O&M activities are as follows:

- The blower is functioning properly, there are no significant air leaks in the piping system, and the VMP and VW wellheads and air distribution piping are in good condition.
- Water levels are approximately the same in the shallow VMPs as in the deep VMPs (at each nested well location), suggesting that both the deep and shallow VMP well screens are under similar hydraulic conditions.
- Water levels in the VWs showed a general increase after the wells were installed, resulting in partially or fully flooded well screens in VW-1, VW-2, and VW-3. VW-1 and VW-3 showed a water level decrease through September 2006; the water levels in these VWs have fluctuated since then, but have always been below top of screen. As stated previously, VW-3 was decommissioned in March 2008. The water levels in VW-4 and VW-5 have been below the wells screens since installation.
- Figure 6 shows groundwater levels in VWs relative to the top of the screened interval. The screen in VW-2 was fully flooded as of May 2006, was lower than the screen interval until October 2006, and had fluctuated above and below the screen since then. As of May 2007, the water level in VW-2 has been below the screen interval. Water levels in VW-1, VW-4, and VW-5 have been below the screen intervals since installation in 2005 and 2008, respectively.
- As shown on Figure 7, groundwater levels in the shallow VMPs have fluctuated slightly since March 2006. However, all of the VMPs have been below the top of the well screen since May 2006, with the exception of VMP-4. VMP-4 was fully saturated in September 2008, but was below the screen interval in subsequent events.

**Figure 6 - Historical Groundwater Levels Relative to Top of VW Screened Intervals  
Redwood Regional Park Service Yard - Oakland, California**

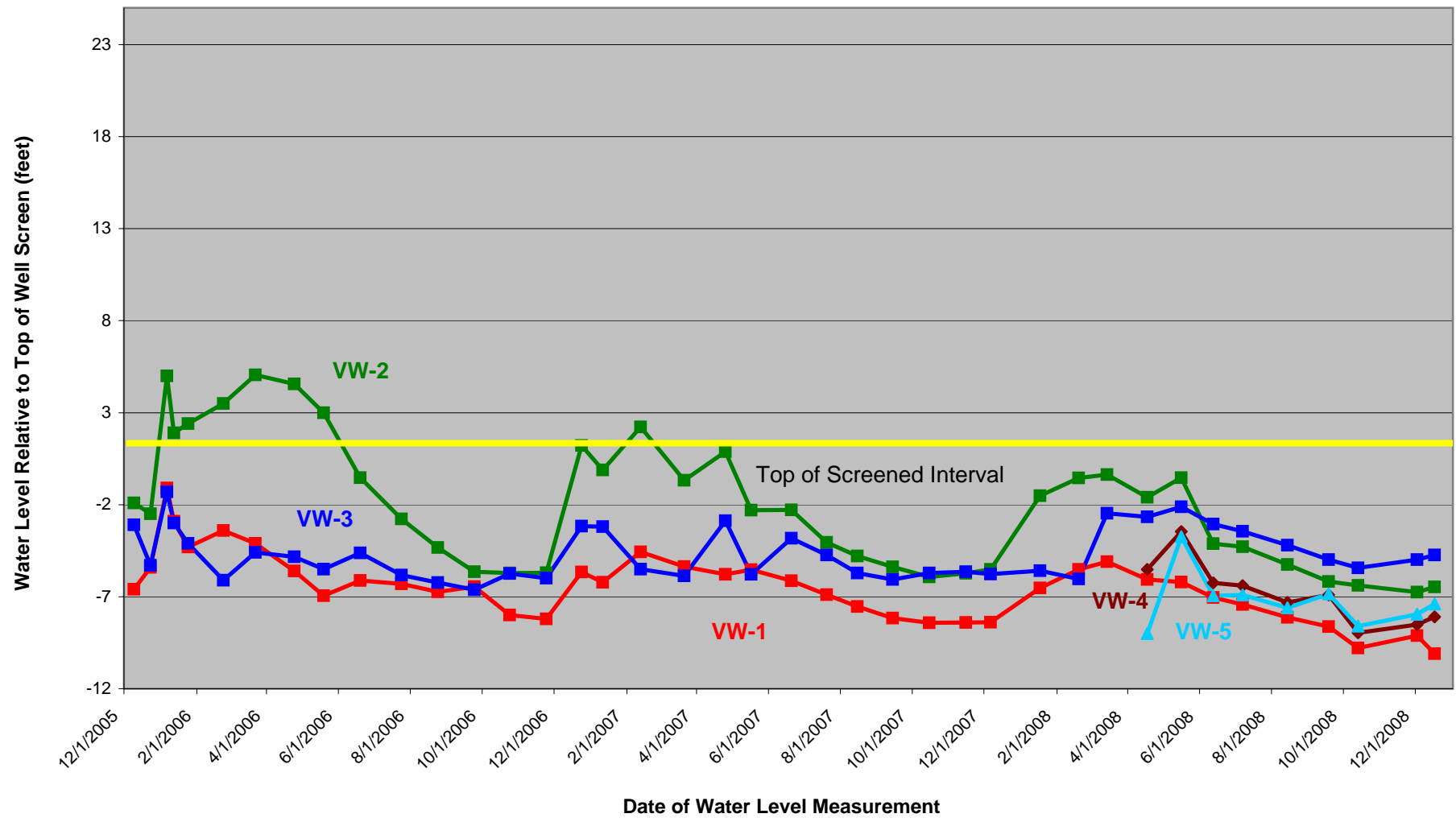

Note: "0" line represents the top of well screened interval;  
water levels above that line represent fully flooded screen.

**Figure 7 - Historical Groundwater Levels Relative to Top of Shallow VMP Screened Intervals  
Redwood Regional Park Service Yard - Oakland, California**

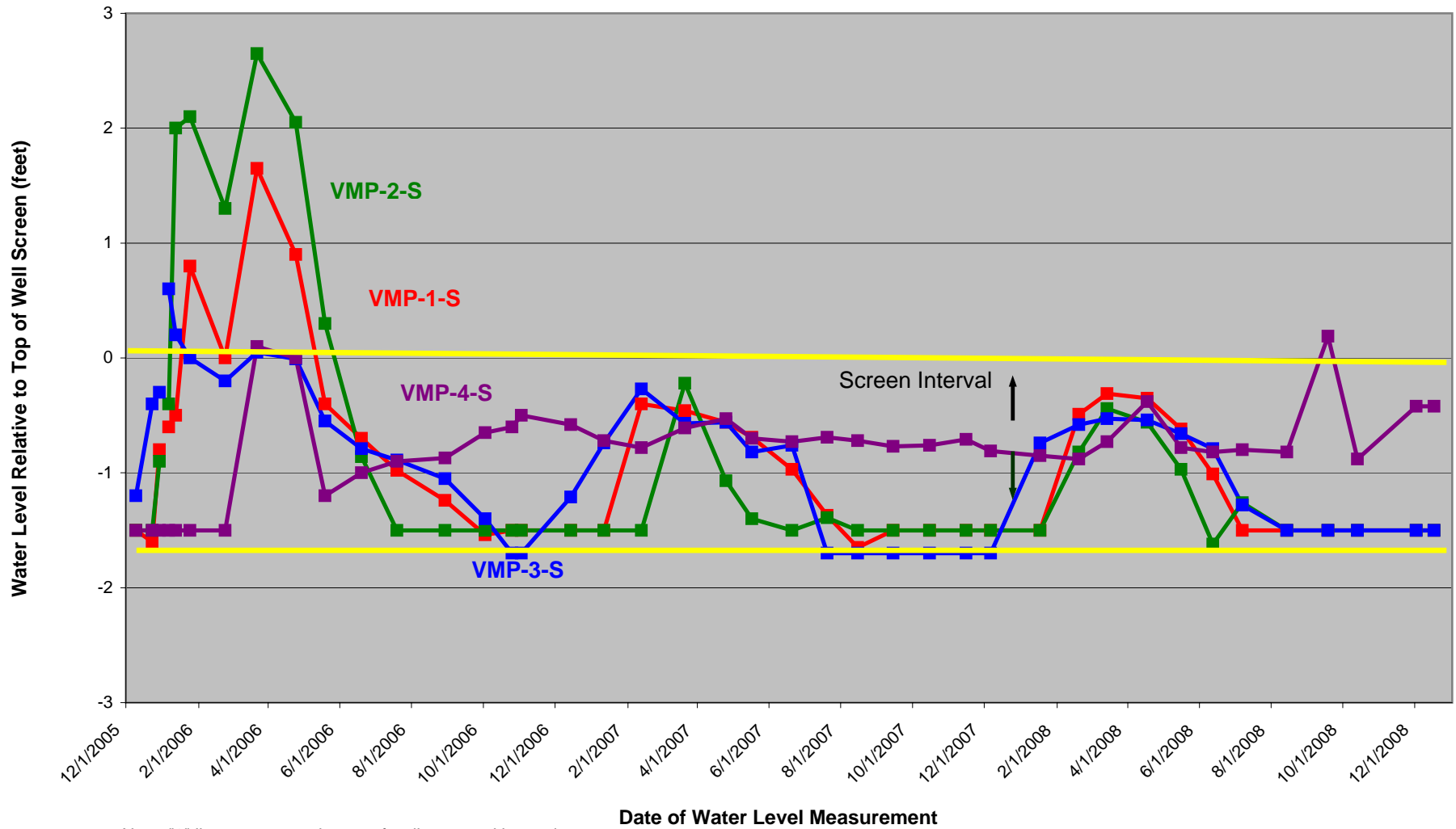

Note: "0" line represents the top of well screened interval;  
water levels above that line represent fully flooded screen.

**Figure 8 - Historical Groundwater Levels Relative to Top of Deep VMP Screened Intervals  
Redwood Regional Park Service Yard - Oakland, California**

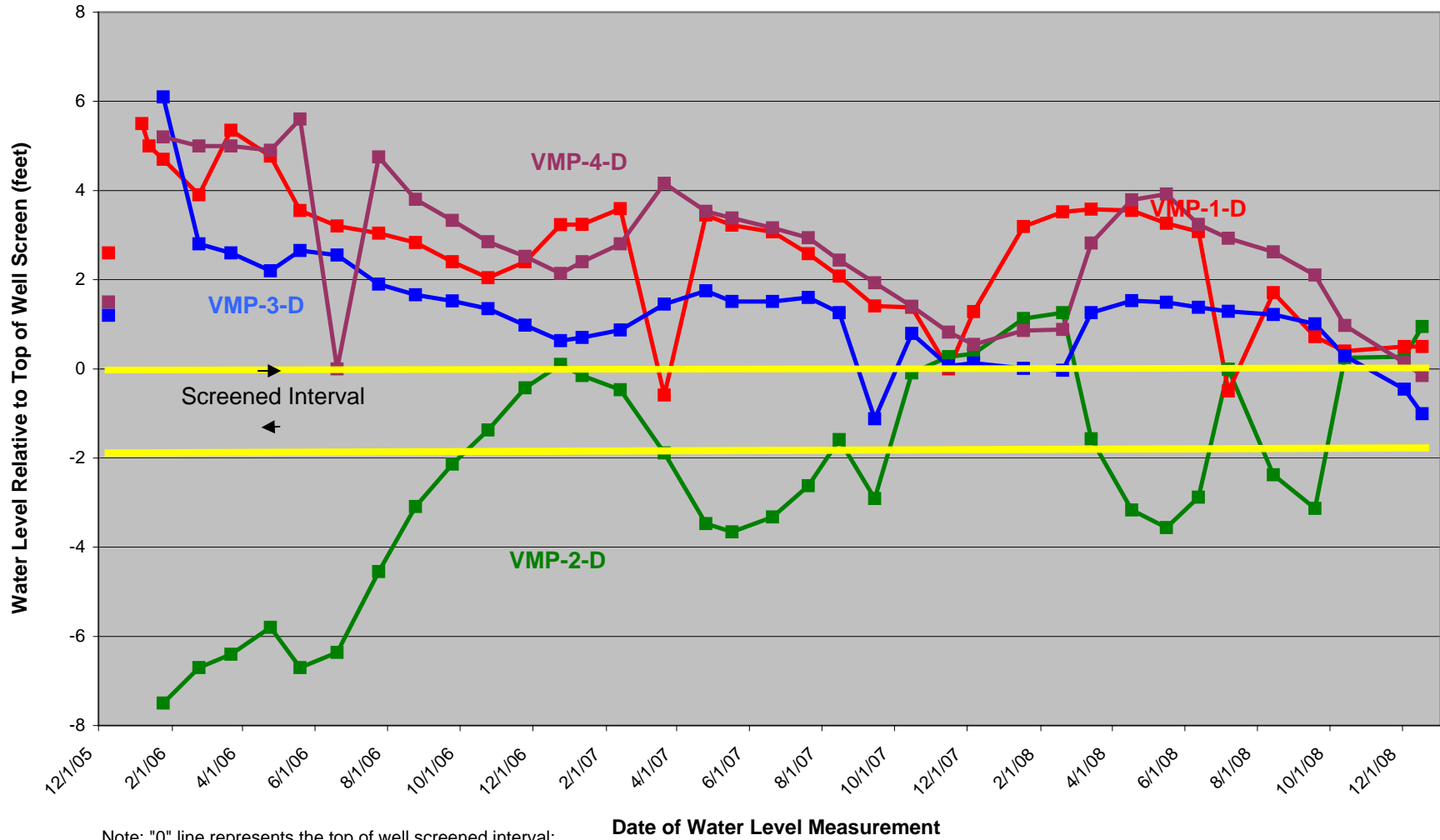

Note: "0" line represents the top of well screened interval;  
water levels above that line represent fully flooded screen.



- As shown on Figure 8, water levels in deep VMPs have been relatively stable since the VMPs were installed. The exception is VMP-2-D, which showed an increase from March 2006 to February 2008, and then showed a sharp decrease to below the screened interval. A slight rise was observed between May and June 2008, but the water level remains below the screened interval. Since the deep VMPs were installed, water levels in three of the four deep VMPs have been above the top of the well screen; only VMP-2-D has an exposed well screen above the water table.
- In previous quarters, air had been injected (and had been since system startup) in the non-flooded portion of the VW-1 and VW-2 screens, but at less-than-optimum flow rates due to the partially flooded screens. However, due to the unusually low level of precipitation during 2008, VW-1 and VW-2 have operated at optimum levels in both the third and fourth quarters.
- No measurable air injection has occurred in VW-4 or VW-5 since their installation in March 2008. Both of the screens in these wells have been partially to fully exposed since installation; however, they are screened across silty clay, which appears relatively impermeable to air flow.

## **IN-SITU RESPIRATION TEST**

Groundwater elevations in the third and fourth quarters of 2008 decreased by an average of 1.6 feet compared to the previous quarter, reflecting the dry season. The lowering of groundwater below the bioventing screened interval zone allowed for a microbial respiration test to be conducted.

## **RESPIRATION TEST**

A respiration test was conducted at the site to assess the degree of microbial biodegradation activity included three vapor monitoring points (VMP-1, VMP-2, and VMP-4) with both nested shallow and deep screen intervals, and four vent wells (VW-1, VW-2, VW-4, and VW-5), for a total of seven measuring points. The test consisted of measuring percent oxygen, percent carbon dioxide, and parts per million by volume air of total volatile hydrocarbons over a 3-day period.

VMP-2 and, to a lesser extent, VMP-1 showed a significant decrease in oxygen that would indicate microbial activity. The position of VMP-2 (nearly midway between the two vent wells) and its relatively higher elevation likely resulted in increased aeration and microbial activity at this point.

While the only response occurred at VMP-2, this area is the most critical for bioventing, as the source area with the residual contamination that feeds the groundwater plume. The 48-hour

respiration test was designed to evaluate oxygen utilization by indigenous microorganisms as an indicator of their ability to utilize the hydrocarbons in soil as a food source. Oxygen utilization rates are determined from data obtained during the in-situ respiration test. The rates are calculated as the zero order relationship between percent oxygen and time, typically measuring the percent oxygen decrease within the first 24-hours to estimate a 24-hour utilization rate. Once oxygen concentrations drop below approximately 5 percent, utilization is considered to have ceased.

To calculate oxygen utilization rates, only the first 24-hour linear portion of the data is used because this represents utilization when the oxygen supply is unlimited, as would occur during active bioventing. To estimate hydrocarbon biodegradation rates from the oxygen utilization rates, a stoichiometric relationship for the oxidation of the contaminant is used. For hydrocarbons, hexane is used as the representative hydrocarbon. The stoichiometric relationship used to determine petroleum degradation rates is:

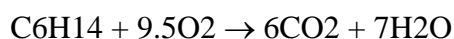

Based on the utilization rates (percent oxygen per day), the biodegradation rate in terms of milligrams of hexane-equivalent per kilogram of soil per day is estimated using the above equation. These terms may be derived through either direct measurement or estimation. The oxygen utilization rate,  $k_o$ , is directly measured in the in-situ respiration test. The ratio of hydrocarbons to oxygen required for mineralization,  $C$ , can be calculated based on stoichiometry (see equation for hexane), but generally will fall between 0.29 and 0.33. This neglects any conversion to biomass, which is small and difficult (if not impossible) to measure.

Figure 9 shows the respiration test results. The oxygen utilization within the first 24 hours is 3.6 percent. This value is lower than the 5.8 and 6.1 percent oxygen utilization within the first 24 hours exhibited in the 2007 and 2006 respiration tests, respectively. The same decreasing utilizing trend occurred in the 48-hour measurement where the oxygen utilization was 6.5 percent in 2008 compared with 11.1 percent in 2007 and 11.1 percent in 2006. Ideally, in the absence of additional hydrocarbon input from leaching residual hydrocarbons entrained in the soil of the original UFST source area, the oxygen utilization rate should decrease due to a reduction in mass over time. However, based on the 2008 data from MW-2, more source contamination is entering the system.

**Figure 9: Respiration Test VMP-2 O<sub>2</sub>-CO<sub>2</sub> Trend Plot**  
**October 13-15, 2008**  
**Redwood Regional Park Service Yard, Oakland, CA**

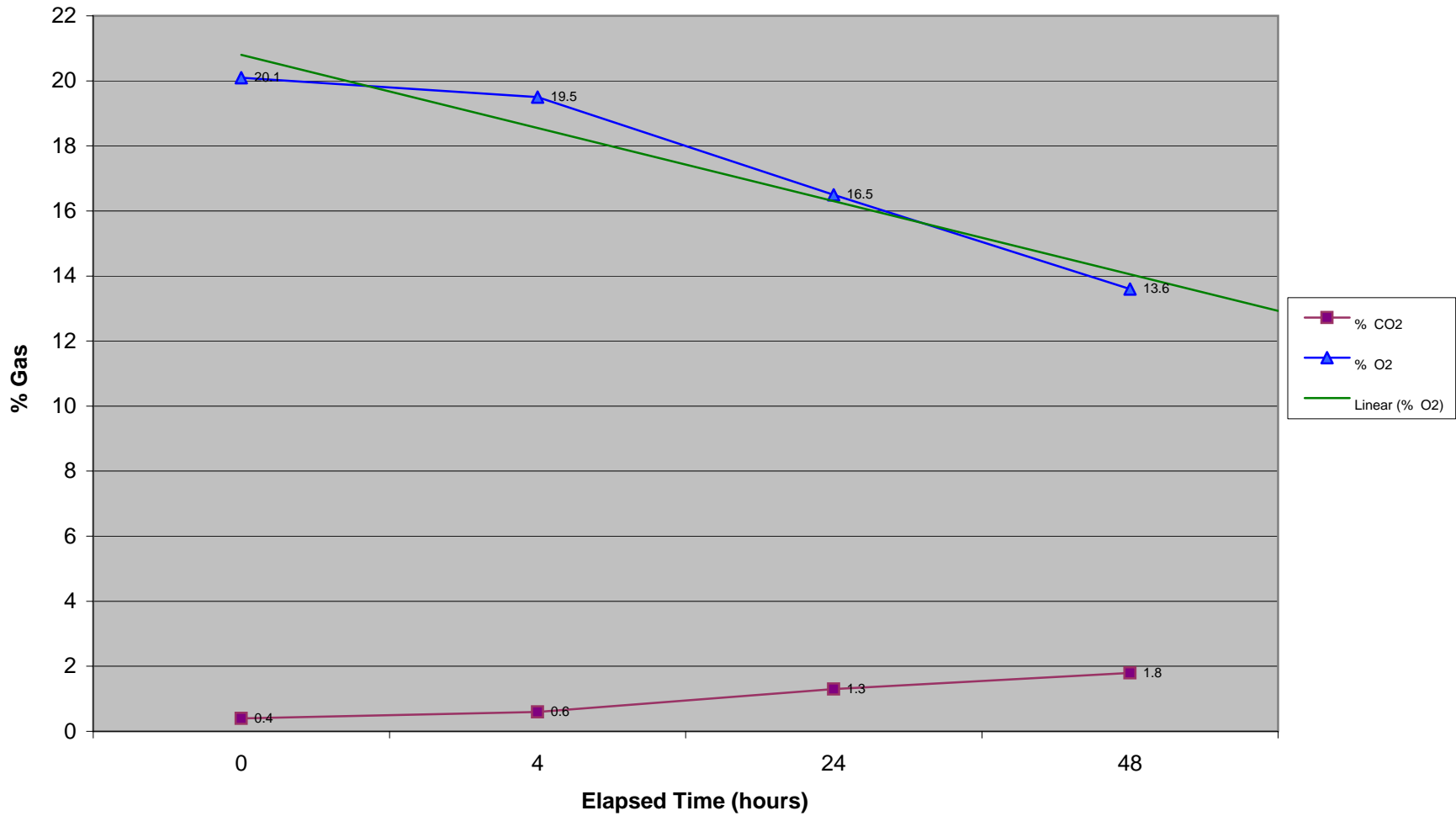

The oxygen utilization are of only respiration test-derived value; the other terms of the equation used to estimate the biodegradation rate,  $k_B$ , are literature derived, summarized by Leeson and Hincee (1996)—such as the soil bulk density, density of oxygen, and mass of hydrocarbon to oxygen required for mineralization (1/3.5).

Using the above assumptions, an oxygen utilization rate of 5.8 percent of oxygen per day would correspond to a biodegradation rate of approximately 1.8 milligrams per kilogram (mg/kg) per day. This translates into a hydrocarbon reduction of 657 mg/kg per year. During the initial respiration test in 2006, it was found that, by using the initial average TPH concentration in soil of 6,000 mg/kg (based on the average of the soil samples from the source area), the oxygen utilization was 4.1 mg/kg per day; this would require approximately 5 years of remediation. However, the lesser utilization rate and the continued input from the source area negate the original estimate.

This calculation provides a reasonable estimate of the amount of time necessary to remediate the site, but only in that the initial soil concentration of 6,000 mg/kg is accurate, and that empirical data associated with the groundwater concentrations (particularly recently at monitoring well MW-2) suggest that a greater hydrocarbon contaminant mass than originally indicated is likely associated with the upgradient source area. The calculation method generally tends to underestimate treatment time because  $k_B$  decreases over time. At the same time, this calculation overestimates treatment time because it does not consider treatment in the expanded bioreactor. Therefore, the calculation must be coupled with process monitoring to provide field-based evidence—such as reduction in the dissolved hydrocarbon fraction in the Redwood monitoring wells—to gauge whether the site actually is remediated within this time period. Due to widely variable contaminant concentrations in the soil (from a few 100 mg/kg to 8,000 mg/kg), the average biodegradation rate does not reflect actual biodegradation rates throughout the site. Biodegradation rates also may fluctuate with season and as contaminant concentrations decrease. Therefore, process monitoring is an important parameter in determining treatment time.

In-situ respiration testing should be used as the primary indicator for site closure. When the in-situ respiration rate in the contaminated area is similar to that in the uncontaminated area, it is likely that the site has been remediated and that final soil sampling can be conducted. In-situ respiration testing to determine remediation success is economically preferable to soil sampling because it eliminates the high cost of intermediate soil sampling. A 2009 respiration test will be performed to evaluate changes in the apparent oxygen utilization rate.



## **4.0 SUMMARY, CONCLUSIONS, AND PROPOSED ACTIONS**

---

This section presents the conclusions and proposed actions with regard to continued operation of the bioventing corrective action system at the Redwood Regional Park Service Yard.

### **SUMMARY AND CONCLUSIONS**

- The blower is operating within design parameters, and there are no physical problems with the blower or air distribution piping.
- Air flow is occurring at an optimum rate in VW-1 and VW-2. This is most likely due to the unusually low levels of precipitation during the third and fourth quarters of 2008.
- No air flow has occurred through the VW-4 or VW-5 screened intervals, even though their screens have been fully to partially exposed since installation in March 2008.
- Continued O&M (including water level measurements) will determine whether air injection rates at the VWs will improve.

### **PROPOSED ACTIONS**

EBRPD proposes to implement the following actions with regard to the bioventing program:

- Continue to conduct system O&M events; however, the frequency will be decreased from monthly to quarterly monitoring events. SES will remain on call if employees of the EBRPD detect a leak or problem with the system.
- Continue to evaluate water levels in VWs and VMPs.
- Conduct an in-situ respiration test in 2009, at such time as water levels drop sufficiently to evaluate response in at least the shallow VMP screens; this should occur in late summer to early fall.
- Continue to report on bioventing system progress/activities in quarterly progress reports, and prepare an annual summary report.

## 5.0 REFERENCES

---

- Alameda County Department of Environmental Health (ACEH), 2005a. Letter regarding Alameda County Health's review of SES Bioventing Pilot Test Report. May 25.
- Alameda County Department of Environmental Health (ACEH), 2005b. Letter approving installation and implementation of bioventing full-scale system. June 24.
- Alameda County Department of Environmental Health (ACEH), 2006b. Letter approving monthly bioventing O&M and reporting and in-situ respiration test. March 15.
- Alameda County Department of Environmental Health (ACEH), 2007b. Letter requesting additional remedial investigation. October 11.
- Alameda County Department of Environmental Health (ACEH), 2008. Letter and Technical Comments approving installation and implementation of bioventing augmentation. February 22.
- Leeson, Andrea and Robert E. Hinchey, 1996. Principals of Bioventing, Battelle Memorial Institute.
- Nilsen, et al., 1979. Relative Slope Stability and Land Use Planning in the San Francisco Bay Region, CA USGS Professional Paper 944.
- Stellar Environmental Solutions, Inc. (SES), 2003. Letter to Alameda County Health Care Services Agency proposing bioventing as a corrective action remedy at Redwood Regional Park Service Yard, Oakland, California. November 6.
- Stellar Environmental Solutions, Inc. (SES), 2004a. Bioventing Feasibility Letter Report – Redwood Regional Park Service Yard, Oakland, California. February 6.
- Stellar Environmental Solutions, Inc. (SES), 2004b. Bioventing Pilot Tests Result Report, Redwood Regional Park Service Yard, Oakland, California. October 29.
- Stellar Environmental Solutions, Inc. (SES), 2006a. Bioventing System Installation and Startup Report – Redwood Regional Park Service Yard, Oakland, California. February 21.

- Stellar Environmental Solutions, Inc. (SES), 2006b. First Quarter 2006 Bioventing Status Report – Redwood Regional Park Service Yard, Oakland, California. April 3.
- Stellar Environmental Solutions, Inc. (SES), 2006c. Second Quarter 2006 Bioventing Status Report – Redwood Regional Park Service Yard, Oakland, California. July 5.
- Stellar Environmental Solutions, Inc. (SES), 2006d. Third and Fourth Quarter 2006 Bioventing Status Report – Redwood Regional Park Service Yard, Oakland, California. December 27.
- Stellar Environmental Solutions, Inc. (SES), 2007a. First and Second Quarter 2007 Bioventing Status Report – Redwood Regional Park Service Yard, Oakland, California. July 9.
- Stellar Environmental Solutions, Inc. (SES), 2008a. Third and Fourth Quarter 2007 Bioventing Status Report – Redwood Regional Park Service Yard, Oakland, California. January 4.
- Stellar Environmental Solutions, Inc. (SES), 2008b. Response to Technical Comments by ACEH and Workplan for Bioventing System Augmentation Redwood Regional Park Service Yard Site – 7867 Redwood Road, Oakland, California. February 7.
- Stellar Environmental Solutions, Inc. (SES), 2008c. First and Second Quarter 2008 Bioventing Status Report – Redwood Regional Park Service Yard, Oakland, California. July 14.

## **APPENDIX A**

---

### **Monthly System O&M Checklists**

**Redwood Regional Park Service Yard  
Bioventing Operations & Maintenance Checklist  
Vapor Monitoring Points**

Date: 7/7/2008

	Depth to Top of Screen (ft below TOC)	Water Level (ft below TOC)	Well Head in Good Condition?
VMP-1-Shallow	9.3	Dry	Yes
VMP-1-Deep	13.4	13.90	Yes
VMP-2-Shallow	9.5	10.76	Yes
VMP-2-Deep	13.9	10.77	Yes
VMP-3-Shallow	9.8	11.08	Yes
VMP-3-Deep	12.0	10.99	Yes
VMP-4-Shallow	15.1	15.90	Yes
VMP-4-Deep	20.8	18.70	Yes

TOC= Top of well Casing

**Redwood Regional Park Service Yard  
Bioventing Operation & Maintenance Checklist  
Blower and Vent Wells**

Date: 7/7/2008

	Air Flow (scfm)		Blower Inlet Vacuum (inches H <sub>2</sub> O)		Blower Outlet Pressure (inches H <sub>2</sub> O)		Depth to Top of Screen (ft below TOC)	Water Level (ft below TOC)	Well Head in Good Condition?
	Before adjustment	After adjustment	Before adjustment	After adjustment	Before adjustment	After adjustment			
Blower <sup>(a)</sup>	NM	NM	22	22	29	29			
VW-1 <sup>(b)</sup>	NM	NM					5.6	13.02	Yes
VW-2 <sup>(b)</sup>	NM	NM					8.4	12.68	Yes
VW-3 <sup>(b)</sup>	NM	NM					8.8	12.25	Yes
VW-4 <sup>(b)</sup>	NM	NM					15	21.40	Yes
VW-5 <sup>(b)</sup>	NM	NM					13	21.90	Yes

Wells on-line (valve open) at arrival 1, 2, 4, and 5 Wells on-line at departure 1, 2, 4, and 5

**Notes:**

<sup>(a)</sup> Air flow measured at sampling port between blower discharge and manifold.

<sup>(b)</sup> Air flow measured at blower manifold sampling port

TOC - Top of Casing of well                      NM = Not Measured

**Checklist Items**

Is any airflow evident through VW-1? 20 inches H<sub>2</sub>O drop  
(Close all VW valves, set outlet pressure at 40 inches H<sub>2</sub>O, then open VW-1 valve only)

Is any airflow evident through VW-2? 20 inches H<sub>2</sub>O drop  
(Close all VW valves, set outlet pressure at 40 inches H<sub>2</sub>O, then open VW-2 valve only)

Is any airflow evident through VW-3? NA inches H<sub>2</sub>O drop  
(Close all VW valves, set outlet pressure at 40 inches H<sub>2</sub>O, then open VW-3 valve only)

Is any airflow evident through VW-4? 0 inches H<sub>2</sub>O drop  
(Close all VW valves, set outlet pressure at 40 inches H<sub>2</sub>O, then open VW-4 valve only)

Is any airflow evident through VW-5? 0 inches H<sub>2</sub>O drop  
(Close all VW valves, set outlet pressure at 40 inches H<sub>2</sub>O, then open VW-5 valve only)

Any audible air leaks in air distribution piping or VW wellheads? No

Blower filter removed and brushed off? Yes Blower filter replaced? No



**Redwood Regional Park Service Yard  
Bioventing Operations & Maintenance Checklist  
Vapor Monitoring Points**

Date: 8/14/2008

	Depth to Top of Screen (ft below TOC)	Water Level (ft below TOC)	Well Head in Good Condition?
VMP-1-Shallow	9.3	Dry	Yes
VMP-1-Deep	13.4	11.69	Yes
VMP-2-Shallow	9.5	Dry	Yes
VMP-2-Deep	13.9	14.15	Yes
VMP-3-Shallow	9.8	Dry	Yes
VMP-3-Deep	12.0	11.71	Yes
VMP-4-Shallow	15.1	15.92	Yes
VMP-4-Deep	20.8	19.83	Yes

TOC= Top of well Casing

**Redwood Regional Park Service Yard  
Bioventing Operation & Maintenance Checklist  
Blower and Vent Wells**

Date: 8/14/2008

	Air Flow (scfm)		Blower Inlet Vacuum (inches H <sub>2</sub> O)		Blower Outlet Pressure (inches H <sub>2</sub> O)		Depth to Top of Screen (ft below TOC)	Water Level (ft below TOC)	Well Head in Good Condition?
	Before adjustment	After adjustment	Before adjustment	After adjustment	Before adjustment	After adjustment			
Blower <sup>(a)</sup>	NM	NM	26	26	22	20			
VW-1 <sup>(b)</sup>	NM	NM					5.6	13.72	Yes
VW-2 <sup>(b)</sup>	NM	NM					8.4	13.65	Yes
VW-3 <sup>(b)</sup>	NM	NM					8.8	13.00	Yes
VW-4 <sup>(b)</sup>	NM	NM					15	22.31	Yes
VW-5 <sup>(b)</sup>	NM	NM					13	22.60	Yes

Wells on-line (valve open) at arrival 1,2,4, and 5 Wells on-line at departure 1,2,4, and 5

**Notes:**

<sup>(a)</sup> Air flow measured at sampling port between blower discharge and manifold.

<sup>(b)</sup> Air flow measured at blower manifold sampling port

TOC - Top of Casing of well                      NM = Not Measured

**Checklist Items**

Is any airflow evident through VW-1? 20 inches H<sub>2</sub>O drop  
(Close all VW valves, set outlet pressure at 40 inches H<sub>2</sub>O, then open VW-1 valve only)

Is any airflow evident through VW-2? 24 inches H<sub>2</sub>O drop  
(Close all VW valves, set outlet pressure at 40 inches H<sub>2</sub>O, then open VW-2 valve only)

Is any airflow evident through VW-3? closed inches H<sub>2</sub>O drop  
(Close all VW valves, set outlet pressure at 40 inches H<sub>2</sub>O, then open VW-3 valve only)

Is any airflow evident through VW-4? 0 inches H<sub>2</sub>O drop  
(Close all VW valves, set outlet pressure at 40 inches H<sub>2</sub>O, then open VW-4 valve only)

Is any airflow evident through VW-5? 0 inches H<sub>2</sub>O drop  
(Close all VW valves, set outlet pressure at 40 inches H<sub>2</sub>O, then open VW-5 valve only)

Any audible air leaks in air distribution piping or VW wellheads? No

Blower filter removed and brushed off? Yes Blower filter replaced? No

**Redwood Regional Park Service Yard  
Bioventing Operations & Maintenance Checklist  
Vapor Monitoring Points**

9/18/2008

	Depth to Top of Screen (ft below TOC)	Water Level (ft below TOC)	Well Head in Good Condition?
VMP-1-Shallow	9.3	Dry	Yes
VMP-1-Deep	13.4	12.68	Yes
VMP-2-Shallow	9.5	Dry	Yes
VMP-2-Deep	13.9	14.17	Yes
VMP-3-Shallow	9.8	Dry	Yes
VMP-3-Deep	12.0	12.46	Yes
VMP-4-Shallow	15.1	14.91	Yes
VMP-4-Deep	20.8	20.66	Yes

TOC= Top of well Casing

**Redwood Regional Park Service Yard  
Bioventing Operation & Maintenance Checklist  
Blower and Vent Wells**

Date: 9/18/2008

	Air Flow (scfm)		Blower Inlet Vacuum (inches H <sub>2</sub> O)		Blower Outlet Pressure (inches H <sub>2</sub> O)		Depth to Top of Screen (ft below TOC)	Water Level (ft below TOC)	Well Head in Good Condition?
	Before adjustment	After adjustment	Before adjustment	After adjustment	Before adjustment	After adjustment			
Blower <sup>(a)</sup>	NM	NM	NA	30	NA	20			
VW-1 <sup>(b)</sup>	NM	NM					5.6	14.22	Yes
VW-2 <sup>(b)</sup>	NM	NM					8.4	14.58	Yes
VW-3 <sup>(b)</sup>	NM	NM					8.8	13.79	Yes
VW-4 <sup>(b)</sup>	NM	NM					15	21.91	Yes
VW-5 <sup>(b)</sup>	NM	NM					13	21.85	Yes

Wells on-line (valve open) at arrival System not on Wells on-line at departure 1,2,4, and 5

Notes:

<sup>(a)</sup> Air flow measured at sampling port between blower discharge and manifold.

<sup>(b)</sup> Air flow measured at blower manifold sampling port

TOC - Top of Casing of well

NM = Not Measured

Checklist Items

Is any airflow evident through VW-1? 22 inches H<sub>2</sub>O drop  
(Close all VW valves, set outlet pressure at 40 inches H<sub>2</sub>O, then open VW-1 valve only)

Is any airflow evident through VW-2? 24 inches H<sub>2</sub>O drop  
(Close all VW valves, set outlet pressure at 40 inches H<sub>2</sub>O, then open VW-2 valve only)

Is any airflow evident through VW-3? Closed inches H<sub>2</sub>O drop  
(Close all VW valves, set outlet pressure at 40 inches H<sub>2</sub>O, then open VW-3 valve only)

Is any airflow evident through VW-4? 0 inches H<sub>2</sub>O drop  
(Close all VW valves, set outlet pressure at 40 inches H<sub>2</sub>O, then open VW-4 valve only)

Is any airflow evident through VW-5? 0 inches H<sub>2</sub>O drop  
(Close all VW valves, set outlet pressure at 40 inches H<sub>2</sub>O, then open VW-5 valve only)

Any audible air leaks in air distribution piping or VW wellheads? Yes, one leak in line VW-2 and one in VW-4, fixed

Blower filter removed and brushed off? Yes Blower filter replaced? No

**Redwood Regional Park Service Yard  
Bioventing Operations & Maintenance Checklist  
Vapor Monitoring Points**

Date: 10/13/2008

	Depth to Top of Screen (ft below TOC)	Water Level (ft below TOC)	Well Head in Good Condition?
VMP-1-Shallow	9.3	Dry	Yes
VMP-1-Deep	13.4	13.00	Yes
VMP-2-Shallow	9.5	Dry	Yes
VMP-2-Deep	13.9	14.85	Yes
VMP-3-Shallow	9.8	Dry	Yes
VMP-3-Deep	12.0	13.01	Yes
VMP-4-Shallow	15.1	15.98	Yes
VMP-4-Deep	20.8	20.95	Yes

TOC= Top of well Casing

**Redwood Regional Park Service Yard  
Bioventing Operation & Maintenance Checklist  
Blower and Vent Wells**

Date: 10/13/2008

	Air Flow (scfm)		Blower Inlet Vacuum (inches H <sub>2</sub> O)		Blower Outlet Pressure (inches H <sub>2</sub> O)		Depth to Top of Screen (ft below TOC)	Water Level (ft below TOC)	Well Head in Good Condition?
	Before adjustment	After adjustment	Before adjustment	After adjustment	Before adjustment	After adjustment			
Blower <sup>(a)</sup>	NM	NM	20	20	20	20			
VW-1 <sup>(b)</sup>	NM	NM					5.6	15.39	Yes
VW-2 <sup>(b)</sup>	NM	NM					8.4	14.78	Yes
VW-3 <sup>(b)</sup>	NM	NM					8.8	14.23	Yes
VW-4 <sup>(b)</sup>	NM	NM					15	23.96	Yes
VW-5 <sup>(b)</sup>	NM	NM					13	23.60	Yes

Wells on-line (valve open) at arrival 1,2,4,5 Wells on-line at departure 1,2,4,5

**Notes:**

<sup>(a)</sup> Air flow measured at sampling port between blower discharge and manifold.

<sup>(b)</sup> Air flow measured at blower manifold sampling port

TOC - Top of Casing of well                      NM = Not Measured

Checklist Items

Is any airflow evident through VW-1? 20 inches H<sub>2</sub>O drop  
(Close all VW valves, set outlet pressure at 40 inches H<sub>2</sub>O, then open VW-1 valve only)

Is any airflow evident through VW-2? 23 inches H<sub>2</sub>O drop  
(Close all VW valves, set outlet pressure at 40 inches H<sub>2</sub>O, then open VW-2 valve only)

Is any airflow evident through VW-3? NA inches H<sub>2</sub>O drop  
(Close all VW valves, set outlet pressure at 40 inches H<sub>2</sub>O, then open VW-3 valve only)

Is any airflow evident through VW-4? 0 inches H<sub>2</sub>O drop  
(Close all VW valves, set outlet pressure at 40 inches H<sub>2</sub>O, then open VW-4 valve only)

Is any airflow evident through VW-5? 0 inches H<sub>2</sub>O drop  
(Close all VW valves, set outlet pressure at 40 inches H<sub>2</sub>O, then open VW-5 valve only)

Any audible air leaks in air distribution piping or VW wellheads? VW2 leaking in above ground line, repaired

Blower filter removed and brushed off? Yes Blower filter replaced? No

**Redwood Regional Park Service Yard  
Bioventing Operations & Maintenance Checklist  
Vapor Monitoring Points**

Date: 12/2/2008

	Depth to Top of Screen (ft below TOC)	Water Level (ft below TOC)	Well Head in Good Condition?
VMP-1-Shallow	9.3	Dry	Yes
VMP-1-Deep	13.4	12.90	Yes
VMP-2-Shallow	9.5	Dry	Yes
VMP-2-Deep	13.9	Dry	Yes
VMP-3-Shallow	9.8	Dry	Yes
VMP-3-Deep	12.0	11.71	Yes
VMP-4-Shallow	15.1	15.52	Yes
VMP-4-Deep	20.8	20.82	Yes

TOC= Top of well Casing

**Redwood Regional Park Service Yard  
Bioventing Operation & Maintenance Checklist  
Blower and Vent Wells**

Date: 12/2/2008

	Air Flow (scfm)		Blower Inlet Vacuum (inches H <sub>2</sub> O)		Blower Outlet Pressure (inches H <sub>2</sub> O)		Depth to Top of Screen (ft below TOC)	Water Level (ft below TOC)	Well Head in Good Condition?
	Before adjustment	After adjustment	Before adjustment	After adjustment	Before adjustment	After adjustment			
Blower <sup>(a)</sup>	NM	NM	28	28	24	24			
VW-1 <sup>(b)</sup>	NM	NM					5.6	14.71	Yes
VW-2 <sup>(b)</sup>	NM	NM					8.4	15.15	Yes
VW-3 <sup>(b)</sup>	NM	NM					8.8	13.79	Yes
VW-4 <sup>(b)</sup>	NM	NM					15	23.52	Yes
VW-5 <sup>(b)</sup>	NM	NM					13	22.96	Yes

Wells on-line (valve open) at arrival 1,2,4,5 Wells on-line at departure 1,2,4,5

Notes:

<sup>(a)</sup> Air flow measured at sampling port between blower discharge and manifold.

<sup>(b)</sup> Air flow measured at blower manifold sampling port

TOC - Top of Casing of well                      NM = Not Measured

Checklist Items

Is any airflow evident through VW-1? 20 inches H<sub>2</sub>O drop  
(Close all VW valves, set outlet pressure at 40 inches H<sub>2</sub>O, then open VW-1 valve only)

Is any airflow evident through VW-2? 22 inches H<sub>2</sub>O drop  
(Close all VW valves, set outlet pressure at 40 inches H<sub>2</sub>O, then open VW-2 valve only)

Is any airflow evident through VW-3? Closed inches H<sub>2</sub>O drop  
(Close all VW valves, set outlet pressure at 40 inches H<sub>2</sub>O, then open VW-3 valve only)

Is any airflow evident through VW-4? 0 inches H<sub>2</sub>O drop  
(Close all VW valves, set outlet pressure at 40 inches H<sub>2</sub>O, then open VW-4 valve only)

Is any airflow evident through VW-5? 0 inches H<sub>2</sub>O drop  
(Close all VW valves, set outlet pressure at 40 inches H<sub>2</sub>O, then open VW-5 valve only)

Any audible air leaks in air distribution piping or VW wellheads? no

Blower filter removed and brushed off? NA Blower filter replaced? replaced, put in order for more



**Redwood Regional Park Service Yard  
Bioventing Operations & Maintenance Checklist  
Vapor Monitoring Points**

Date: 12/17/2008

	Depth to Top of Screen (ft below TOC)	Water Level (ft below TOC)	Well Head in Good Condition?
VMP-1-Shallow	9.3	Dry	Yes
VMP-1-Deep	13.4	12.52	Yes
VMP-2-Shallow	9.5	Dry	Yes
VMP-2-Deep	13.9	Dry	Yes
VMP-3-Shallow	9.8	Dry	Yes
VMP-3-Deep	12.0	12.61	Yes
VMP-4-Shallow	15.1	15.99	Yes
VMP-4-Deep	20.8	20.94	Yes

TOC= Top of well Casing

**Redwood Regional Park Service Yard  
Bioventing Operation & Maintenance Checklist  
Blower and Vent Wells**

Date: 12/17/2008

	Air Flow (scfm)		Blower Inlet Vacuum (inches H <sub>2</sub> O)		Blower Outlet Pressure (inches H <sub>2</sub> O)		Depth to Top of Screen (ft below TOC)	Water Level (ft below TOC)	Well Head in Good Condition?
	Before adjustment	After adjustment	Before adjustment	After adjustment	Before adjustment	After adjustment			
Blower <sup>(a)</sup>	NM	NM	24	24	24	20			
VW-1 <sup>(b)</sup>	NM	NM					5.6	15.69	Yes
VW-2 <sup>(b)</sup>	NM	NM					8.4	14.87	Yes
VW-3 <sup>(b)</sup>	NM	NM					8.8	13.54	Yes
VW-4 <sup>(b)</sup>	NM	NM					15	23.09	Yes
VW-5 <sup>(b)</sup>	NM	NM					13	22.39	Yes

Wells on-line (valve open) at arrival 1,2,4, 5 Wells on-line at departure 1,2,4,5

Notes:

<sup>(a)</sup> Air flow measured at sampling port between blower discharge and manifold.

<sup>(b)</sup> Air flow measured at blower manifold sampling port

TOC - Top of Casing of well      NM = Not Measured

Checklist Items

Is any airflow evident through VW-1? 20 inches H<sub>2</sub>O drop  
(Close all VW valves, set outlet pressure at 40 inches H<sub>2</sub>O, then open VW-1 valve only)

Is any airflow evident through VW-2? 22 inches H<sub>2</sub>O drop  
(Close all VW valves, set outlet pressure at 40 inches H<sub>2</sub>O, then open VW-2 valve only)

Is any airflow evident through VW-3? NA inches H<sub>2</sub>O drop  
(Close all VW valves, set outlet pressure at 40 inches H<sub>2</sub>O, then open VW-3 valve only)

Is any airflow evident through VW-4? 0 inches H<sub>2</sub>O drop  
(Close all VW valves, set outlet pressure at 40 inches H<sub>2</sub>O, then open VW-4 valve only)

Is any airflow evident through VW-5? 0 inches H<sub>2</sub>O drop  
(Close all VW valves, set outlet pressure at 40 inches H<sub>2</sub>O, then open VW-5 valve only)

Any audible air leaks in air distribution piping or VW wellheads? Yes - fixed leak in VW-1 line

Blower filter removed and brushed off? Yes Blower filter replaced? No