



May 24, 2006

RECEIVED

By loprojectop at 2:32 pm, May 24, 2006

Mr. Jerry Wickham
Alameda County Environmental Health
1131 Harbor Bay Parkway, Suite 250
Alameda, CA 94502

Subject: HVDPE System Design, Operations, and Maintenance Plan
245 8th Street
Oakland, California
AEI Project No. 116907
ACEH Toxics Case RO0000202

Dear Mr. Wickham:

Enclosed is one electronic copy of the recently completed HVDPE System Design, Operations, and Maintenance Plan prepared for the subject facility at the request of Alameda County Environmental Health (ACEH).

If you have questions or comments, please don't hesitate to contact me or Peter McIntyre at (925) 283-6000.

Sincerely,
AEI Consultants

Richard J. Bradford
Project Manager

Enclosure

RECEIVED

By loppjectop at 2:32 pm, May 24, 2006

May 24, 2006

**HVDPE SYSTEM DESIGN, OPERATIONS,
AND MAINTENANCE PLAN**

245 8th Street
Oakland, California

AECH Toxics Case RO0000202
AEI Project No. 116907

Prepared For:

Mr. Jerry Wickham
Alameda County Environmental Health
1131 Harbor Bay Parkway, Suite 250
Alameda, CA 945023-6577

On Behalf:

Mr. Victor Lum
Vic's Automotive
245 8th Street
Oakland, CA 94607

Prepared By:

AEI Consultants
2500 Camino Diablo, Suite 200
Walnut Creek, CA 94597
(800) 801-3224

AEI

TABLE OF CONTENTS

1.0 INTRODUCTION	1
2.0 SITE DESCRIPTION	1
3.0 SITE HISTORY	1
4.0 GEOLOGY AND HYDROLOGY	2
5.0 SITE CONCEPTUAL MODEL	3
6.0 PILOT TEST SUMMARY	4
7.0 HVDPE SYSTEM DESIGN	4
7.1 System Overview	5
7.1 Power Availability	5
7.2 Major Equipment and Specifications	6
7.2.1 <i>Liquid Ring Pump</i>	6
7.2.2 <i>Thermal / Catalytic Oxidizer</i>	6
7.2.3 <i>Air Stripper</i>	7
7.2.4 <i>Water Knock-out Tank</i>	7
7.2.5 <i>System Control Panel</i>	7
7.3 Dual Phase Extraction Well System	7
7.3.1 <i>Drop Tube Design</i>	8
7.3.2 <i>Wellhead Configuration</i>	8
7.3.3 <i>Piping, Valves, and Manifold System</i>	8
7.4 Instrumentation and Controls	8
7.4.1 <i>Flow Measurement</i>	8
7.4.2 <i>Vacuum / Pressure</i>	9
7.4.3 <i>Liquid Level</i>	9
7.5 Sample Ports	9
7.6 Monitoring Points	9
7.7 Equipment Enclosure	10
7.8 Security and Safety Measures	10
7.9 Remote Monitoring System	10
8.0 PROJECT SCHEDULE	10
8.1 Permitting	11
8.1.1 <i>City of Oakland (2 to 4 weeks)</i>	11
8.1.2 <i>EBMUD (4 to 6 weeks)</i>	11
8.1.3 <i>BAAQMD (7 to 10 weeks)</i>	11
8.2 Vendor Selection / Equipment Procurement	11
8.3 Collection of Baseline Data	11
8.4 System Construction	12
8.4.1 <i>Electricity and Gas Installation</i>	12
8.4.2 <i>Trenching and Piping Installation</i>	12
8.4.3 <i>Equipment Enclosure</i>	12
8.5 Equipment Testing	13
8.6 System Startup	13

9.0 ROUTINE MONITORING, OPERATIONS AND MAINTENANCE.....	14
9.1 Monthly Monitoring and Reporting.....	14
9.2 Quarterly Monitoring and Reporting	14
9.3 Operations and Maintenance Plan.....	15
10.0 SYSTEM STARTUP REPORT	15
11.0 SITE HEALTH AND SAFETY	16
12.0 REFERENCES.....	17
13.0 LIMITATIONS AND SIGNATURES	18

FIGURES

<i>FIGURE 1</i>	<i>SITE LOCATION MAP</i>
<i>FIGURE 2</i>	<i>SITE LAYOUT PLAN</i>
<i>FIGURE 3</i>	<i>EQUIPMENT LAYOUT PLAN</i>
<i>FIGURE 4</i>	<i>GROUNDWATER ANALYTICAL DATA (2/9/06)</i>
<i>FIGURE 5</i>	<i>PIPING & INSTRUMENTATION DIAGRAM</i>
<i>FIGURE 6</i>	<i>WELLHEAD CONSTRUCTION DETAILS</i>

TABLES

<i>TABLE 1</i>	<i>SAMPLING SCHEDULE SUMMARY</i>
<i>TABLE 2</i>	<i>GROUNDWATER ELEVATION DATA</i>
<i>TABLE 3</i>	<i>GROUNDWATER FLOW SUMMARY</i>
<i>TABLE 4</i>	<i>GROUNDWATER SAMPLE ANALYTICAL DATA</i>
<i>TABLE 5</i>	<i>GROUNDWATER SAMPLE ANALYTICAL DATA: FUEL ADDITIVES</i>
<i>TABLE 6</i>	<i>SOIL BORING GROUNDWATER SAMPLE ANALYTICAL DATA</i>
<i>TABLE 7</i>	<i>GROUNDWATER SAMPLE ANALYTICAL DATA: GENERAL CHEMISTRY</i>
<i>TABLE 8</i>	<i>SOIL SAMPLE ANALYTICAL DATA</i>
<i>TABLE 9</i>	<i>SOIL VAPOR SAMPLE ANALYTICAL DATA</i>
<i>TABLE 10</i>	<i>EXTRACTION EVENT VAPOR SAMPLE DATA (TPH-G)</i>

APPENDICIES

<i>APPENDIX A</i>	<i>CALCLEAN DATA REPORT</i>
<i>APPENDIX B</i>	<i>OBSERVATION WELL DRAWDOWN DATA PLOTS</i>
<i>APPENDIX C</i>	<i>PROCESS FLOW DIAGRAM</i>
<i>APPENDIX D</i>	<i>TYPICAL DPE EXTRACTION WELL</i>
<i>APPENDIX E</i>	<i>EQUIPMENT SPECIFICATIONS</i>
<i>APPENDIX F</i>	<i>MAJOR SYSTEM EQUIPMENT</i>
<i>APPENDIX G</i>	<i>OTHER SYSTEM MATERIALS</i>
<i>APPENDIX H</i>	<i>MAINTENANCE RECOMMENDATIONS</i>

1.0 INTRODUCTION

AEI Consultants (AEI) has prepared this remediation system design, operations, and maintenance plan on behalf of Mr. Victor Lum of Vic's Automotive, owner and operator of the fuel station and auto repair business located at 245 8th Street, Oakland, California (Figure 1). AEI has been retained to provide environmental engineering and consulting services related to the release of fuel hydrocarbons from the former underground storage tank (UST) system on the property. The investigation and mitigation of the release is being performed under the direction of the Alameda County Environmental Health (ACEH) local oversight program. ACEH has concurred with AEI's recommendation to implement high vacuum dual phase extraction (HVDPE) as an interim corrective action measure using fixed-base equipment. This work plan presents the design, operations, and maintenance plan for a HVDPE remediation system.

2.0 SITE DESCRIPTION

The subject property (hereafter referred to as the "site" or "property") is located in a mixed commercial and residential area of Oakland, Alameda County, California. The site is a lot on the south corner of Alice Street and 8th Street, and is currently developed with a gasoline station and automotive repair facility (Figure 2). The property covers approximately 9,375 square feet and is improved with an approximately 1,200 square foot building located centrally on the property used for automotive repair, cashier, and office. The current UST hold and the dispenser island are located to the north of the building, along 8th Street. The remainder of the property is paved with asphalt.

3.0 SITE HISTORY

Between June 1993 and August 1994, AEI removed a total of seven (7) underground storage tanks (USTs) from the property. The tanks consisted of four (4) 1,000-gallon and two (2) 6,000-gallon gasoline tanks and one (1) 250-gallon waste oil tank. The former locations of the tanks are shown on Figure 2. Impacted soil was removed from beneath the former tank area. Groundwater was encountered beneath the former 6,000-gallon tanks. Light non-aqueous phase liquid (LNAPL) was observed on the water table beneath the southern tank. The excavated soil was transported to an appropriate disposal facility and the excavation was backfilled with clean fill material. A new tank system was installed just west of the dispenser island.

Two groundwater monitoring wells (MW-1 and MW-2) were installed in July 1995. The first two episodes of monitoring revealed total petroleum hydrocarbons as gasoline (TPH-g) and Benzene up to 210,000 µg/L and 720 µg/L, respectively, in MW-2. LNAPL was discovered in MW-1, which ranged from 1.20 to 4.39 feet thick between December 1995 and March 1996.

Three soil borings (SB-1 through SB-3) were advanced in August 1996. Groundwater samples collected from each of the borings contained TPH-g and Benzene ranging from 120,000 to 140,000 µg/L, and from 12,000 to 19,000 µg/L, respectively. Methyl tertiary-butyl ether (MTBE) was also present in all three samples, up to 27,000 µg/L. Although free phase product was not observed in

the field, qualitative laboratory observations indicated an immiscible sheen in the samples. Manual bailing and pumping of LNAPL from MW-1, and monitoring of MW-2 occurred intermittently through 1997. Two additional groundwater monitoring wells (MW-3 and MW-4) were installed in May 2001. Refer to Tables 1 to 3 for data collected from these wells. An LNAPL recovery pump was installed in MW-1 in June 2001.

Fourteen (14) additional soil borings were performed on and offsite in 2003, from which soil, groundwater, and soil vapor samples were collected to further characterize the extent of the release. On January 11, 19, and 20, 2005, AEI installed a total of six (6) additional wells; three (3) extraction/monitoring wells on the subject site (MW-5 to MW-7) and three (3) extraction/monitoring wells at 708 Alice Street (MW-10 to MW-12). Note that wells MW-8 and MW-9 were proposed for installation in the public right of way, north of and west of the site. However, due to insurance and permitting limitations imposed by the City of Oakland, these wells have not been installed, and likely cannot be installed in City of Oakland right-of-way. Surveying of the six new wells was complete as of January 2006.

A 15-day HVDPE free product recovery and pilot test event was conducted from July 11 to July 27, 2005. Vapor flow rates ranged from approximately 170 to 190 standard cubic feet per minute (scfm) under a sustained vacuum of 16 to 17 inches of mercury. A total of 80,740 gallons of groundwater was recovered and treated at an average flow rate of approximately 4.1 gallons per minute over the 15-day pilot test. Significant drawdown and vacuum response was observed in the vadose and saturated zone monitoring points. Approximately 5 pounds per day (lbs/day) of dissolved phase and 697 lbs/day of vapor phase hydrocarbons were recovered. Based on these favorable results and subsequent concurrence by ACEH, implementation of HVDPE using fixed base equipment is currently underway.

Due to the elevated concentration of volatile fuel hydrocarbons on the site and extending offsite, soil gas sampling was requested by ACEH. AEI prepared and submitted a soil gas investigation work plan to ACEH for review and comment on May 12, 2006.

Refer to Figure 2 for locations of monitoring wells, soil borings, and former USTs. Historical soil, groundwater, and soil vapor sample analytical data is included in Tables 4 through 10.

4.0 GEOLOGY AND HYDROLOGY

The elevation of the site is approximately 27 to 29 feet above mean sea level (msl). The site is flat; however, the topography of the area slopes gently to the southwest. The site is located between Lake Merritt and the Oakland Inner Harbor channel, approximately one-half mile from each. The near surface sediments are mapped as Holocene and Pleistocene Merritt Sand Deposits (Qms) (Helley, et al, 1997). Depth to the Franciscan Formation basement underlying the unconsolidated deposits is approximately 400 feet (Norfleet, 1998).

Based on the logs of soil borings advanced at the site, the native soils generally consist of fine to medium grained sands with silt and clay present to at least 28 feet bgs, the deepest explored at the site. Typically, silty and clayey fine grained sand have been encountered to depths of 15 to 18 feet bgs. This is underlain by poorly graded, clean to slightly clayey and silty fine to medium sand. Sediments have been relatively uniform throughout the investigation area and both sand units appear to represent a single hydrologic system. Groundwater depths have typically ranged from 13 to 17 feet bgs, corresponding to elevation of approximately 10 to 14 feet above msl. Annual water levels fluctuate by approximately 3 to 4 feet. Groundwater has consistently flowed to the south-southeast with a hydraulic gradient of approximately 10^{-3} ft/ft. Groundwater elevation data is summarized in Table 2 and a summary of the historical groundwater flow direction in Table 3.

5.0 SITE CONCEPTUAL MODEL

The release occurred from the former gasoline USTs, located on the western side of the property. During removal of the southern-most 6,000-gallon UST, free phase product was observed in the excavation, floating on the water table. The quantity of fuel released is unknown.

Based on historical depth to water measurements and the former depths of the UST(s), the product was released directly onto or just above the water table. Over time, and with seasonal water table fluctuations, the fuel product has significantly impacted the capillary fringe and has created a smear zone from depths of approximately 14 to 20 feet bgs. Refer to Table 8 for soil sample analytical data. The free phase product has been entrained, or trapped, within the pore space of the fine grained sediments. In addition, a significant mass of mobile, free phase product has been observed in the release area as well as detected as a dissolved phase plume in monitoring wells and soil borings.

Groundwater predominantly flows in a south-southeasterly direction, causing the release spread in this direction. Soil and groundwater data collected approximately 60 to 80 feet to the south in the vacant lot (708 Alice) reveals that significant hydrocarbons have migrated beneath the two apartment buildings. Although LNAPL has not been measured in MW-10, MW-11, or MW-12, the dissolved phase concentrations (essentially at saturation) and soil sample data from these wells and borings SB-2, SB-3, and SB-4 support the conclusion that mobile, free phase hydrocarbons have migrated at least this distance to the south and beneath Alice Street. The extent of dissolved phase hydrocarbon plume has been reasonably well defined with wells MW-3 (up-gradient) and MW-4 (cross-gradient, east) and borings SB-6 and SB-12 (cross-gradient, west) and SB-13 to SB-15 (down-gradient).

No water wells were identified near the site during a well survey of Department of Water Resource (DWR) records. Other potential human exposure pathways include volatilization of contaminants into occupied spaces from soil and/or groundwater as well as direct contact with impacted soil or groundwater, if construction activities were to occur.

6.0 PILOT TEST SUMMARY

A HVDPE pilot test was conducted from July 11 to July 27, 2005. The mobile high vacuum multi-phase extraction unit was provided and operated by CalClean, Inc. The unit consisted of a 25 horsepower liquid ring pump capable of up to 450 scfm, water knock-out tank, thermal oxidizer, diesel generator with propane supply, 1,000-gallon water holding tank, and two 200-lb carbon vessels connected in series for secondary groundwater treatment.

Monitoring wells MW-1, 2, 5, 6, and 7 were connected to the vacuum manifold with 1.25-inch diameter flexible vacuum hose for use as extraction wells. The hose was protected with temporary drive bumps so as to not unnecessarily close drive areas of the property. The hose was connected to the wellhead and affixed with a vacuum gauge.

CalClean personnel were onsite 24 hours per day monitoring operating parameters and ensuring optimal system uptime. The extraction event was originally scheduled to run for 5 days. However, after several days of extraction, it was evident that hydrocarbon recovery rates were high and the event was extended to 15 days in an effort to maximize hydrocarbon mass removal. Overall, the system uptime was approximately 95%.

Total influent hydrocarbon concentrations, as measured in the field by the Horbia organic vapor analyzer, ranged from approximately 6,350 part per million by volume (ppmv) to 18,170 ppmv. Toward the end of the event, concentrations stabilized in the 8,000 to 9,000 ppmv range. Vapor flow rates, when extracting on the 5 wells ranged from approximately 170 to 190 scfm, under a sustained vacuum at the manifold of 16 to 17 inches of mercury (in Hg). A total of 80,000 gallons of groundwater was recovered and treated over the 15-day test for an average liquid flow rate of about 4.1 gpm.

Approximately 10,600 pounds of vapor phase fuel hydrocarbons were removed during the event. Assuming a 95% system uptime, approximately 697 pounds per day of vapor phase hydrocarbons were recovered. Based on an average TPH-g concentration of 101,333 μL (average of wells MW-2, MW-5, and MW-6), and an average flow rate of 4.1 gpm, approximately 5 lbs/day of dissolved phase hydrocarbons were recovered. Refer to Appendix A for a summary of pilot test data and a copy the CalClean HVDPE report, dated August 10, 2006. For more detailed information on the pilot test please refer to AEI's *High Vacuum Dual Phase Extraction Event Report*, dated December 14, 2005.

7.0 HVDPE SYSTEM DESIGN

The overall system design presented herein is based on pilot testing data and practical experience designing and operating HVDPE systems. The main objective for designing a HVDPE system, or any in-situ remediation system for that matter, is to achieve the greatest mass removal in the most efficient, cost-effective, and timely manner.

7.1 System Overview

High vacuum dual phase extraction (HVDPE) is a proven and cost-effective remediation technology for a wide range of soil types and subsurface conditions. HVDPE simultaneously extracts groundwater, NAPL, and soil vapor by applying a high vacuum with a liquid ring pump to an adjustable drop tube sealed within an extraction well.

The pump, which simultaneously extracts liquid and vapor phases, is connected to an air-water phase separator. The liquid is then pumped from the separator to an air stripping unit and (if necessary) through two activated carbon adsorption vessels connected in series prior to discharging. The treated groundwater will be discharged under a groundwater discharge permit to an onsite sanitary sewer lateral. The vapor stream is routed to a thermal oxidizer for treatment. The effluent meeting air discharge permit requirements is vented to the atmosphere.

The five existing monitoring wells (MW-1, 2, 5, 6, and 7) used for the pilot test will be converted to dual phase extraction wells. Trenching will be performed and 2 to 2.5-inch diameter schedule 80 polyvinyl chloride (PVC) conveyance piping will be installed in the locations shown in Figure 3. The piping will be connected to the wellheads using clear flexible vacuum hose. The manifold will be equipped with control valves for balancing flows between the individual extraction wells. The equipment enclosure will occupy an 8 by 18 foot parking space on the eastern side of the garage.

Refer to Appendix C for a simple flow diagram of treatment process and to Figure 5 for a more-detailed piping and instrumentation diagram. A schematic of a typical dual phase extraction well is included in Appendix D and actual wellhead construction details are presented in Figure 6.

7.1 Power Availability

Power will be required to operate the liquid ring pump, air stripper, transfer pumps, and other treatment system equipment. The thermal oxidizer will require an auxiliary fuel source, such as propane or natural gas.

AEI has recently confirmed the availability of 230/115V three-phase electrical power at the site with sufficient capacity for additional circuits at the 200A main breaker panel. Three-phase power is preferred over single-phase, since it reduces pump motor wear and the pump motors will have about ½ the amperage draw, which allows for installation of lower amperage circuit breakers. A survey of electrical equipment loads was recently performed by AEI. A licensed electrician will be contracted to perform a final power inspection. The electrician will check the actual electric load at the site by turning on all of the electrical equipment and measuring the current draw. The amperage of the remediation equipment has been summarized and will be given to the electrician as a reference for sizing and installing the circuit breakers.

Natural gas maps and archived records of the Pacific Gas and Electric Company (PG&E) obtained by AEI indicated that gas service was disconnected at the request of the property owner sometime prior to 1990. The gas meter was removed and service cut off at gas main running on the far side of Alice Street. AEI requested PG&E tap the line verifying it was not active. Restoring gas service

to the site will likely cost in excess of \$10,000 with a minimum of 6 months up to 1 year wait time for gas service engineering and design by PG&E. This will cause significant delays to the project implementation; therefore, propane will be the auxiliary fuel source. Refillable propane tanks will be installed at least 10 feet from the equipment trailer on a small concrete foundation secured with chains and protected by channel guard railing.

7.2 Major Equipment and Specifications

Major equipment for the HVDPE systems includes a liquid ring pump, a thermal/catalytic oxidizer for vapor abatement, an air stripper for groundwater treatment, and air-water phase separator or knock-out tank. Refer to Appendix F for more information on the major system equipment and Appendix E for detailed specifications.

7.2.1 Liquid Ring Pump

A liquid ring pump (LRP) is the standard vacuum pump used for HVDPE systems. The maximum flow rate observed during the pilot test was nearly 200 scfm. Applying a 1.25 safety/capacity factor for future expansion, vacuum piping and/or other unforeseen losses, a design flow rate of 250 scfm is obtained. Optimal design vacuum for HVDPE is in the range of 16 to 22 in Hg. Therefore, a 15 horsepower LRP capable of up to 28 in Hg with a maximum flow rate of approximately 280 scfm is selected for the requisite system flow rate and vacuum range. The LRP will be fitted with a pressure gauge on the discharge side and a Dwyer DS-300 series flow sensor with a 4 to 20 mA transmitter.

7.2.2 Thermal / Catalytic Oxidizer

Based on high sustained vapor recovery rates observed during the pilot test (in the 8,000 to 9,000 ppmv range) a dual mode thermal/catalytic oxidizer will be used as the primary vapor abatement device. Vapors from the liquid ring pump and air stripper effluent will be connected to the oxidizer influent. The air stripper vapor effluent will also be used for oxidizer pressure-side dilution air.

Furthermore, the oxidizer will be outfitted with a Soil-Therm's patented *Jet-Therm* stainless steel burner with a 100:1 turn down ratio, flame arrestor, safety interlocks, and a lower explosive limit (LEL) monitor on the inlet to measure total influent VOC concentrations. The oxidizer will be able to handle flows up to 360 scfm and can safely process vapor streams with VOC concentrations up to 80% LEL or 11,200 ppmv gasoline vapors¹. The enclosed, direct-flame oxidizer is well-insulated with ceramic lining for near zero heat loss to the outside and operating temperatures up to 1600 °F.

The BAAQMD considers thermal oxidization achieving at least 98.5% destruction efficiency (by weight) to be a best available control technology for vapor extraction

¹ The LEL for gasoline is 14,000 ppmv, therefore 80%LEL is 11,200 ppmv.

systems. The oxidizer will likely require the use of auxiliary fuel in the form of propane or natural gas to maintain a destruction efficiently meeting the BAAQMD permit requirements. The oxidizer will maintain a minimum destruction efficiency of >99.9% in thermal mode and >98.5% in catalytic mode.

High recovery rates are expected during the first six months to a year of operation followed by a gradual decrease in the hydrocarbon recovery rate. The oxidizer is equipped to run in catalyst mode when VOC concentrations drop to below the 3,000 to 4,000 ppmv range.

7.2.3 Air Stripper

Air stripping is an effective method for treating low to moderate concentrations of VOCs in extracted groundwater. Air strippers use ambient air to strip VOCs from the liquid into the vapor phase. Stripping of groundwater will be performed prior to discharging to the sanitary sewer. The average flow rate observed during the pilot test was about 5 gpm. Applying a 1.25 safety/capacity factor, a liquid design flow rate of 10 gpm is obtained. A low profile tray-style air stripper capable of processing up to 25 gpm will be installed. If required per permit conditions, the air stripper will be followed by two 10 gpm carbon vessels in series for secondary groundwater treatment. A bag-filter will be installed on the influent side of the air stripper to the remove fines from the incoming liquid stream.

7.2.4 Water Knock-out Tank

An air-water phase separator or knockout tank with 2.5-inch piping connections will be used to separate the vapor and liquid phases. The 50-gallon capacity separator will be equipped with a polyester filter element, demister pad, and site glass with adjustable intrinsically safe liquid level switches (low-low shut-off, high pump on, and high-high shut-off). A drain and cleanout port with plug will be installed at the bottom to allow for periodic maintenance.

7.2.5 System Control Panel

A three phase 208-230V, 125 amp service NEMA 4 control panel enclosure with locking door and main disconnect switch will be used to control the system and operating parameters. This control panel will include a programmable logic controller (PLC) with a digital message display and operating pushbuttons.

7.3 Dual Phase Extraction Well System

The extraction well system is comprised of individual extraction wells, drop tubes, wellhead configurations, conveyance piping, and a manifold system that connects the extraction wells to a common point. Monitoring wells MW-1, 2, 5, 6 and 7 with well screens intersecting the capillary fringe, vadose, and saturated zones will be utilized as extraction wells.

7.3.1 Drop Tube Design

The drop tube or “stinger” should be sized to maintain a linear gas velocity in the range of 2,500 to 3,000 feet per minute (fpm) or greater. The drop tube will be constructed of 1 to 1.25-inch diameter flexible vacuum hose and schedule 40 PVC pipe. A 1.25-inch diameter drop tubes will require approximately 25 to 30 scfm of vapor flow to provide the required velocity for entrainment of liquid particles in the gas stream. The drop tube will be affixed with a vacuum gauge and connected to the conveyance piping with flexible vacuum hose.

7.3.2 Wellhead Configuration

Dual phase extraction wellheads will be constructed from 4-inch diameter well pump seals with a 1 to 1.25-inch hole for the drop tube. The stinger is placed through the inner hole to the desired depth and the well seal is slipped inside the monitoring well casing. Four evenly spaced hex-head bolts are tightened deforming the rubber seal gasket and securing the well seal around the drop tube and to inside of the well casing. Threaded ports on the top side of the well seal are used to install a casing vacuum gauge and ambient bleed air or priming valve. The drop tube is connected with flexible vacuum hose and cam-lock fittings to the conveyance piping. Extra vacuum hose is left coiled in the well box to allow for easy adjustment of the drop tube depth. Since the depth to water is less than 40 feet bgs, priming the drop tube by introducing significant quantities of ambient air should not be necessary.

7.3.3 Piping, Valves, and Manifold System

Extraction system conveyance piping will be constructed of 2 to 2.5-inch diameter schedule 40 PVC pipe. The manifold system will be constructed of threaded 2.5 to 3-inch diameter schedule 40 CPVC pipe or similar material. Clear sections of PVC will be installed at the manifold for making qualitative observations of system influent. The manifold system will include flow control valves, vacuum gauges, and sample ports for each extraction well.

7.4 Instrumentation and Controls

Instrumentation to monitor system operating parameters include: flow sensors, vacuum/pressure gauges, liquid level switches, and temperature gagues. Direct reading gauges are preferred for easy and rapid measurements in the field. Instrumentation is often integrated with a central control panel and programmable logic controller (PLC). A brief description of the instrumentation used to monitor the system operating parameters is present below.

7.4.1 Flow Measurement

Flow rates of individual phases (i.e., gas, water, and LNAPL) must be monitored separately after the soil vapor and liquid phases are separated. The total system air

flow will be measured after the air-water separator using a Dwyer DS-300 series averaging pitot tube with a 4 to 20mA transmitter. The volume of recovered groundwater will be measured using a flow totalizer. The air stripper vapor and liquid flow rates will be measured. Dilution air flow rate will be measured since this will need to be accounted for when calculating the mass removal rates. Small rotameters will be installed at each wellhead to measure the ambient air dilution flow, which is usually in the range of 0 to 5 scfm.

7.4.2 Vacuum / Pressure

A vacuum gauge will be installed on the manifold for each extraction well. The wellhead will be affixed with two vacuum gauges, one to monitor casing vacuum and one to monitor drop tube vacuum. A pressure gauge will be installed on the pressure side of the liquid ring pump and the discharge side of the air stripper.

7.4.3 Liquid Level

Intrinsically safe liquid level switches will be installed on the air-water separator. High and low level shut off switches will be installed in case the pump on or pump off switches malfunction. A site glass will be installed to make visual observations of liquid level and amount NAPL in the air-water separator.

7.5 Sample Ports

Sample ports will be installed for each extraction well at the manifold. A total system sample port will also be placed on the manifold. Water sample ports will be installed in the water knock-out tank, air stripper influent, air stripper effluent, after the first carbon vessels (mid-carbon), and after the second carbon vessel (post-carbon) to monitor dissolved phase hydrocarbon concentrations to comply with the groundwater discharge permit. Sample ports will also be installed on the oxidizer influent and the stack for BAAQMD monitoring requirements.

7.6 Monitoring Points

Monitoring points will be employed for measuring the subsurface response to HVDPE. The network of monitoring points will comprise of monitoring wells MW-3, 4, and 10 to measure water level drawdown and soil gas probes GP-1 through GP-4 to monitor the vadose zone response to vacuum over time. Soil gas probes will be used to monitor concentrations of TPH-g, BTEX, MTBE and gases, such as O₂, CO₂, N₂, and CH₄, which are indicators of aerobic biodegradation. Each well monitoring point (MW-3, 4, and 10) will be equipped with a pressure transducer with data-logging capability and a temperature sensor. The pressure transducer will be set to record pressure (as feet of water column above the transducer) and temperature at regular time intervals. The data will be downloaded, as needed, at monthly and/or quarterly visits.

7.7 Equipment Enclosure

Remediation systems are commonly housed in existing buildings, sheds, or trailer to protect the equipment from sunlight, rain, and the elements, to reduce the potential for damage or vandalism, and to control excessive noise pollution. The remediation system will be housed and transported to the site in a 6 by 12-foot enclosed utility trailer. Equipment will be laid out by the manufacturer to maximize use of the interior space without making maintenance overly difficult. A fence with a locking gate will be installed around the entire trailer.

7.8 Security and Safety Measures

Security, general safety, and seismic safety measures have been incorporated into the system design. A main disconnect switch will be installed in an accessible location near the main breaker panel and/or outside the equipment enclosure to allow the electricity supply to be blocked in an emergency situation. Furthermore, all equipment will be housed in an enclosed trailer surrounded by fencing with locking gate to reduce the potential for damage or vandalism. The equipment trailer will be secured and anchored to the ground using four 48 to 60-inch tie-downs or auger anchors to reduce the potential for shaking and movement during an earthquake and to prevent possible theft. Flexible piping and seismic safety shut-off valves will be installed on the propane supply lines. The valves will be set to close if the force and ground acceleration associated with a magnitude 5 or greater earthquake is observed at the site. The propane tanks will be installed at least 10 feet from the equipment trailer. The propane tanks will be placed on a small concrete foundation secured with chains and protected by channel guard railing. Responsible site personnel will be given an overview of the system operation, normal conditions, and emergency shut down procedures.

7.9 Remote Monitoring System

The system will be equipped with a remote monitoring and alarm notification system that will call the system operator using an auto-dialer if an alarm condition is detected or shut-down occurs. Remote monitoring of a limited number of system operating parameters can be performed and the system restarted from the office via cellular telemetry. The remote monitoring system will reduce the number of site visits and will let AEI know right away of any problems that require immediate and/or future attention.

8.0 PROJECT SCHEDULE

The main project tasks are permitting, electricity and gas setup, vendor selection and equipment procurement, collection of baseline data, system construction, testing, and startup. Ultimately, the project schedule will depend on the pace of the various permitting agencies.

8.1 Permitting

8.1.1 City of Oakland (2 to 4 weeks)

A permit to modify the existing electrical facilities has already been obtained from the City of Oakland. A City of Oakland permit for connecting and discharging to an onsite sanitary sewer lateral will be obtained by the time the groundwater discharge permit issued by the East Bay Municipal Utilities District (EBMUD).

8.1.2 EBMUD (4 to 6 weeks)

A *Groundwater Discharge Permit* application required for discharge of treated groundwater to the sanitary sewer collection system has already been submitted to East Bay Municipal Utilities District (EBMUD) environmental services department. The permit standard terms and conditions will outline the discharge limits and will include a description of the compliance sampling protocol and schedule. It takes 4 to 6 weeks to obtain this permit from the time the application is completed and fees are paid.

8.1.3 BAAQMD (7 to 10 weeks)

A Bay Area Air Quality Management District (BAAQMD) permit application has been submitted for construction and operation the of remediation system equipment and abatement devices. The *Authority to Construct* is issued first and the *Permit to Operate* is issued after construction and prior to start up. The purpose of this permitting process is to reduce fugitive emissions from groundwater cleanup sites and improve the air quality by requiring all operations use the Best Available Control Technology (BACT). This permit will take 7 to 10 weeks to acquire and will likely be the most costly and take the longest to obtain.

8.2 Vendor Selection / Equipment Procurement

AEI will procure the system from a reputable vendor based on equipment availability, costs, and other factors, such as easy of maintenance and the warranty. AEI will select the best possible equipment for the least amount of cost. However, AEI will not sacrifice equipment quality or reliability just to obtain the lowest possible price.

8.3 Collection of Baseline Data

Collection of baseline analytical data and information on the subsurface conditions must be performed prior to start-up. This will give complete picture of the site conditions prior to implementation of HVDPE. The depth to groundwater in extraction and monitoring wells will be measured with an electronic level indicator. Concentrations of TPH-g, BTEX, MTBE, O₂, and CO₂ in the soil gas will be measured at the soil gas probes. Groundwater quality parameters, including: temperature, pH, dissolved oxygen (DO), specific conductivity, oxidation/reduction potential (ORP) will be collected from each well. All on

and off-site monitoring wells will be samples and the thicknesses of NAPL will gauge with an oil-water interface meter.

8.4 System Construction

At least three days prior to commencing field work, the trenching and piping locations will be marked with white paint and Underground Service Alert (USA) will be notified. A private utility locator will be contracted to identify any private utilities in the work area. Construction activities will be performed by AEI and appropriate subcontractors in accordance with the 2001 California Building, Electrical, Plumbing, Mechanical, and Fire Codes, and applicable local codes and standards.

8.4.1 Electricity and Gas Installation

All electrical equipment and wiring will comply with NFPA-70, the National Electric Code (NEC), and applicable local codes and standards. All electrical wiring and installations will be performed by a California-licensed electrician in conformance with the 2001 California Electrical Code and the 2005 NEC. All gas plumbing work will be performed by a California-licensed plumber in conformance with the 2001 California Plumbing and Fire Codes.

8.4.2 Trenching and Piping Installation

Heavy equipment, including a backhoe and compactor will be rented. The trenches will be excavated to a depth of 28-inches bgs. A 2-inch thick layer of crushed stone will be placed in trench bottoms. Conveyance piping will be installed and connected per specification under the direction of AEI's field engineer. All piping will be leak tested prior to backfilling the trenches. A locator strip made of solid copper wire along with caution tape will be installed along the straight runs of piping. Well vaults (18-inches square) with a H20K (20,000 pound) traffic rating will be installed around the wellheads and finished flush to grade. After leak testing is complete and all connections secured, the trenches will be backfilled and compacted in 6 to 8-inch lifts. The fills will be compacted with a vibratory plate compactor to 90% *Modified Proctor* density.

8.4.3 Equipment Enclosure

The remediation system will be housed and transported to the site in a 6 by 12-foot enclosed utility trailer. A fence with a locking gate will be installed around the remediation trailer perimeter. The trailer will be secured and anchored to the ground using four 48 to 60-inch tie-downs or auger anchors at each corner. These anchors will prevent potential theft and to reduce the potential for shaking and movement during a significant earthquake (magnitude 5.0 or greater).

8.5 Equipment Testing

Before start-up all piping and above ground equipment shall be inspected, checked against the final specifications, and tested. AEI will prepare a comprehensive pre-startup checklist inclusive of the manufacturer's suggested checks and test and the final specifications for the major system components. The performance of individual components shall first be checked one by one. Next, the performance of combined system components should be verified. Any abnormal conditions encountered not per specification will be corrected prior to start-up. Once AEI's field engineer has confirmed that all systems have been checked and meet specification, the start-up operations will begin.

8.6 System Startup

The startup phase of operations will include about 7 days of adjustments to the vacuum level and total system flow, balancing of flows at each extraction well, and adjustments to the drop tube depth. The system operations will be monitored daily for the first week, weekly for the first month, and on a monthly basis or as needed for the first year. At minimum the following parameters will be monitored and recorded on field data sheets during start-up:

- Influent, operating, and effluent temperatures
- Total system vapor and liquid flow rates
- Applied vacuum to the drop tube and well casing at each extraction well
- PID measurements for the total system and from each well
- Liquid flow totalizer readings in gallons
- Stinger depth in each well
- Ambient bleed air flow rate at the manifold and each well
- Air stripper influent, operating, and effluent vapor and liquid flow
- Vacuum response at soil gas probe monitoring points
- Depth to water in the well monitoring points
- Equipment hour meter readings

AEI will collect one set of influent and effluent groundwater samples within 24-hours of system startup in accordance with the EBMUD discharge permit terms and conditions. Sample analytical results will be reviewed prior to authorizing discharge to the sewer. Sample results forwarded via fax or email to the appropriate EBMUD personnel. AEI will collect one set of influent and effluent vapor samples within 24-hours of the start-up in accordance with the BAAQMD air permit terms and conditions. Sample analytical results will be reviewed and forwarded via fax or email to the appropriate BAAQMD personnel. Air and groundwater samples will be analyzed on a 24-hour turn around basis for TPH-g by Method SW8015Cm and BTEX and MTBE by Method SW8020B. However, permits conditions may require analysis of BTEX and MTBE by Method SW8260B.

Daily monitoring will occur for the first week and weekly monitoring for the first month of operations. Monthly and quarterly monitoring will occur on a regular basis thereafter as described in the next section.

9.0 ROUTINE MONITORING, OPERATIONS AND MAINTENANCE

The HVDPE system is designed for continuous operation and will operate twenty four hours per day seven days a week. System uptime of greater than 90% is anticipated. The system operations will be monitored on a monthly and quarterly basis and equipment will be inspected monthly. Routine maintenance will be performed as required and per the manufacture's recommendations and warranty requirements.

9.1 Monthly Monitoring and Reporting

The same operating parameters monitored during system startup will be measured on a monthly basis. Sample collection, sample analyses, reporting, and record keeping will be in conformance with the BAAQMD and EBMUD permit requirements.

AEI will collect three sets of influent and effluent vapor samples into Tedlar™ bags and analyze them in the field with a photo-ionization detector (PID) calibrated to read in hexane equivalents in accordance with BAAQMD *Permit to Operate* (Plant No. 17789). One set of groundwater influent and effluent samples will be collected in accordance with the EBMUD groundwater discharge permit.

Samples will be transported on ice under proper chain of custody protocol to McCampbell Analytical, Inc. of Pacheco, California (Department of Health Services Certification #1644) for analyses of TPH-g by Method SW8015Cm and BTEX and MTBE by Method SW8020B. However, BAAQMD and EBMUD permits conditions may require analysis of BTEX and MTBE by Method SW8260B.

AEI will measure the oxygen and carbon dioxide concentrations in the soil gas monthly to monitor for signs of in-situ respiration and biodegradation. Samples will be collected into Tedlar™ bags and analyzed in the field using a multiple gas meter.

9.2 Quarterly Monitoring and Reporting

Quarterly monitoring will involve performing all monthly monitoring activities as described above in conjunction with quarterly groundwater monitoring and soil gas sampling. The HVDPE system will be shut-down at least one day prior to groundwater or soil gas sampling. Sample collection, sample analyses, reporting, and record keeping will be in conformance with the BAAQMD and EBMUD permit requirements.

The wellheads will be configured as such to allow for ease of sampling and system restarting. Samples will be transported on ice under proper chain of custody protocol to McCampbell Analytical, Inc. of Pacheco, California (Department of Health Services Certification #1644) for analyses of TPH-g by Method SW8015Cm and BTEX and MTBE by Method SW8020B.

Soil gas samples will be collected from the individual monitoring points using an evacuated Summa canister as described in AEI's *Soil Gas Investigation Work Plan*, dated May 12, 2006. Soil gas samples will be shipped by ground under proper chain of custody protocol to Air Toxics, Ltd (Department of Health Services Certification #02110CA) for analyses of TPH-g by Method TO-3 and for BTEX and MTBE by Method TO-15.

Quarterly groundwater monitoring reports will also include cumulative soil vapor and dissolved phase recovery data as well on the soil gas sampling results.

9.3 Operations and Maintenance Plan

After startup and prior to the first monthly visit, AEI will develop a system specific operations and maintenance (O&M) plan. The O&M plan will be one of the most useful documents associated with the project. It will provide general information on normal system operating parameters, routine maintenance, and the frequency at which servicing shall be performed. Maintenance will be performed per the manufacture's recommendation and in compliance with the warranty. Routine maintenance will help to ensure system reliability and prevent premature equipment failure. The O&M plan will strike a balance between maintenance and the cost to perform the maintenance services. The HVDPE system was designed and equipment was selected such that maintenance would be minimal. Lastly, the O&M plan will also include non-routine activities such as troubleshooting of major and minor system components.

10.0 SYSTEM STARTUP REPORT

Within three months of receipt of all necessary analytical data, AEI will prepare a system startup report to present the data and observations made during the baseline monitoring and system start-up phases. The information developed in this report will be very important in evaluating the expected time to reach the initial cleanup goals, long-term O&M costs, and estimated quantities of liquid and vapor phase contaminants being treated, and the probability of successful site remediation. The startup report will include a summary of the remediation system construction and startup activities, baseline field measurements and other information collected prior to startup, laboratory analytical reports, and results of equipment performance checks. The startup report will summarize the final system operating parameters. The typical turn-around time for receipt of analytical data is within one week of sample collection.

11.0 SITE HEALTH AND SAFETY

A site-specific health and safety plan (HASP) will be prepared to include the following elements: a description of the site and of the known physical and chemical hazards, list of key site personnel, delineation of the work area, levels of protection to be worn, procedures to control site access, decontamination measures, and emergency procedures, including telephone numbers for the nearest hospital and for key site personnel.

The HASP will be consistent with *NIOSH Occupational Safety and Health Guidance Manual for Hazardous Waste Site Activities* (1985), EPA Order 1440.3 – *Respiratory Protection*, EPA Order 1440.2 – *Health and Safety Requirements for Employees Engaged in Field Activities*, EPA *Standard Operating Safety Guide* (1984), federal OSHA regulations, particularly 29 CFR 1910 and 1926, Cal/OSHA and local regulations, and other EPA guidance as provided.

Prior to commencing field activities, a site safety meeting will be held at a designated command post near, but not in, the working area. Emergency procedures will be outlined at this meeting, including an explanation of physical hazards associated with the field work and the hazards of known or suspected contaminants of concern. The route to the nearest hospital will be identified and a map with directions will be included in the health and safety plan (HASP). All site personnel will be in Level D personal protection equipment, which is the anticipated maximum level of protection needed. A working area will be established with barricades, orange traffic cones, and/or yellow caution tape to delineate the exclusion zone where a work uniform, hard hats, and steel-toed shoes must be worn, and where unauthorized personnel will not be allowed.

The HASP will be onsite at all times during the project and during operation of the system. All personnel performing work in the field will be required to have completed a 40-hour HAZWOPER training session in accordance with 29 CFR 1910.120.

12.0 REFERENCES

29 CFR parts 1910 and 1926 federal OSHA regulations.

CalClean, *High Vacuum Dual Phase Vacuum Extraction and Treatment Report*, August 10, 2005.

EPA, Order 1440.3 – Respiratory Protection.

EPA, Order 1440.2 – Health and Safety Requirements for Employees Engaged in Field Activities.

EPA, Standard Operating Safety Guide 1984.

Helley, E.J., et al, *Quaternary Geology of Alameda County and Surrounding Areas, California*, 1997.

Norfleet Consultants, *Groundwater Study and Water Supply History of the East Bay Plain, Alameda and Contra Costa Counties, CA*, June 19, 1998

Suthersan, S. S., *Remediation Engineering Design Concepts*, Lewis Publishers, CRC Press Inc., Boca Raton, FL, 1997.

U.S. Army Corps of Engineers, *EM 1110-1-4010 Multi-Phase Extraction Engineering and Design Manual*, June 1999.

U.S. Army Corps of Engineers, *EM 1110-1-4001 Soil Vapor Extraction and Bioventing Engineering and Design Manual*, June 2002.

13.0 LIMITATIONS AND SIGNATURES

This work plan, which has been prepared by AEI Consultants on behalf of Mr. Victor Lum, owner and operator of Vic's Automotive located at 245 8th Street in the City of Oakland, California, presents a HVDPE remediation system design based on both pilot test data and practical experience designing and operating HVDPE systems. HVDPE technology is proposed as an interim measure to mitigate the release of fuel hydrocarbons from the former UST system at the property. The specified work has been performed in accordance with generally accepted practices and standards in the environmental engineering and geology fields. The project will be overseen and the report(s) will be signed by an AEI California registered professional geologist or engineer in accordance with the Business and Professional Code, Chapters 7 and 12.5, and the California Code of Regulations, Title 16, Chapters 5 and 29.

We look forward to your comments regarding this system design, operations, and maintenance plan. Should you have any questions or comments or need additional information, please contact either of the undersigned.

Sincerely,
AEI Consultants

Richard J. Bradford
Senior Staff Engineer

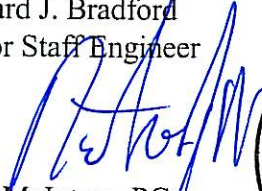
Peter McIntyre, PG
Senior Project Manager

Joseph Derhake, PE
Senior Project Engineer

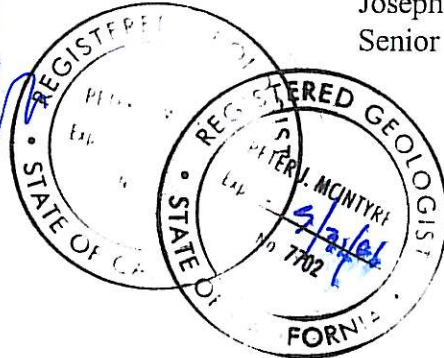

Distribution:

Mr. Victor Lum
Vic's Automotive
245 Alice, Oakland, CA 94607

Mr. Jerry Wickham
ACEH
1131 Harbor Bay Parkway, Suite 250
Alameda, CA 94502

Mr. Sunil Ramdass
UST Cleanup Fund
1001 I Street, Sacramento, CA 94224

FIGURES

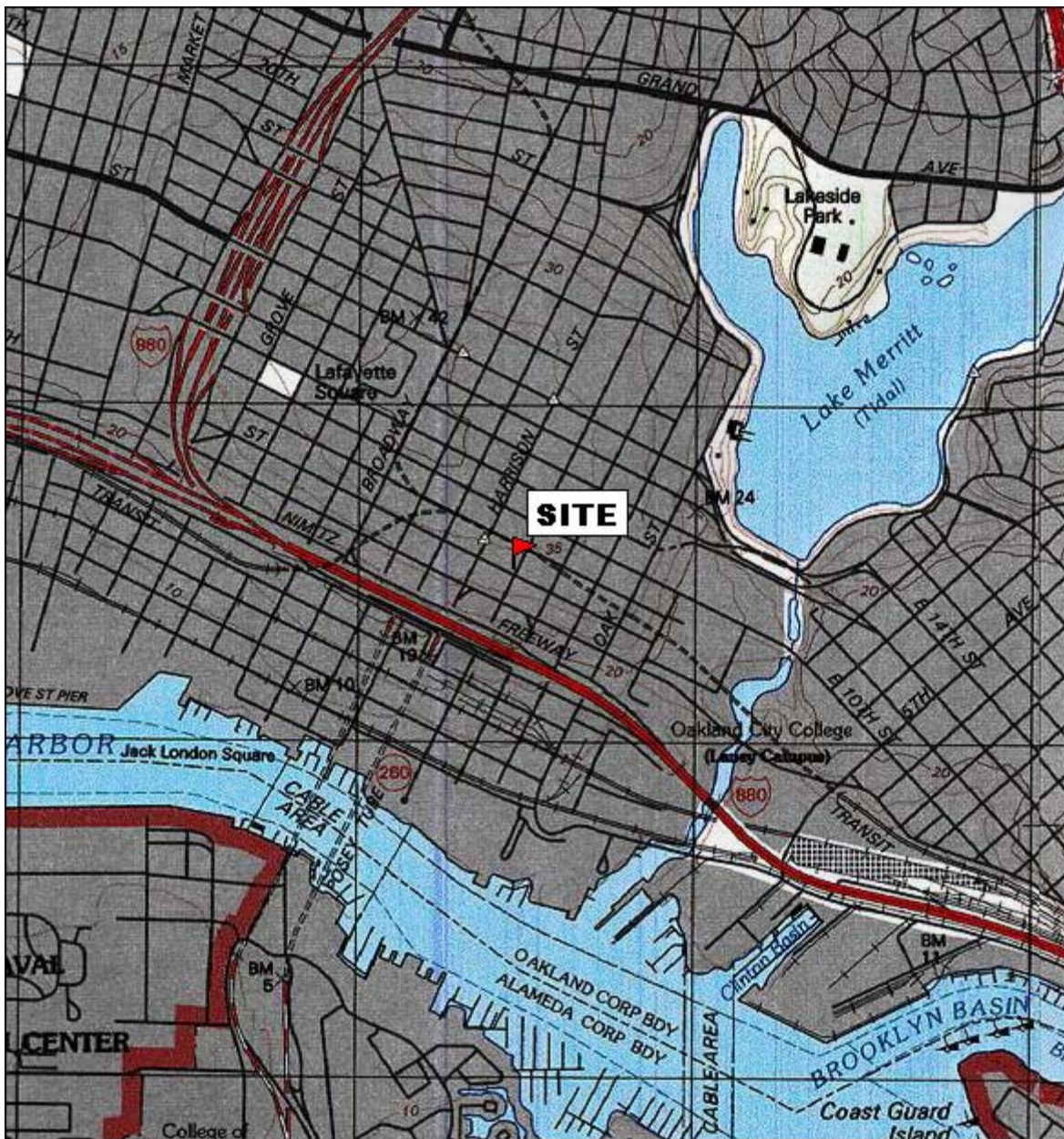

TN \star MN
15 1/2°



Printed from TOPO! ©2001 National Geographic Holdings (www.topo.com)

AEI CONSULTANTS 2500 CAMINO DIABLO BLVD, STE 100, WALNUT CREEK	
SITE LOCATION MAP	
245 8 th STREET OAKLAND, CALIFORNIA	FIGURE 1 AEI PROJECT No. 116907

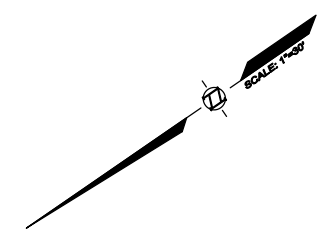

LEGEND

- ⊕ SOIL BORING (8/9/96)
- SOIL BORING (4/02 & 3/03)
- MONITORING WELL
- SOIL GAS PROBE (PROPOSED)
- ⋯ FORMER UST LOCATION
- BUILDING FOOTPRINT

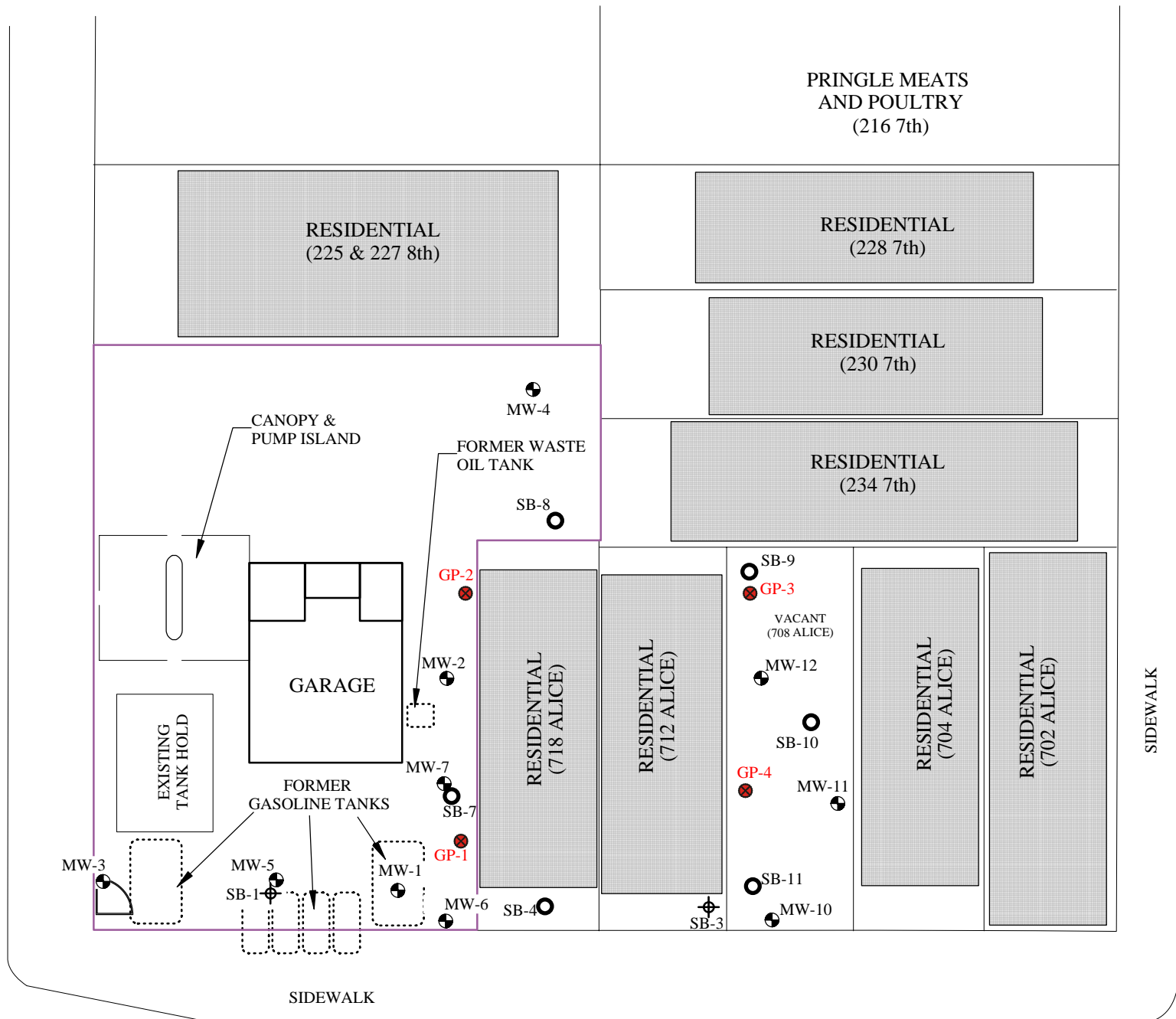

EIGHTH STREET

SEVENTH STREET

ALICE STREET

SIDEWALK

SIDEWALK

SIDEWALK

SIDEWALK

SIDEWALK

COMMERCIAL AND RESIDENTIAL

AEI CONSULTANTS
 2500 CAMINO DIABLO, SUITE 200, WALNUT CREEK, CA

SITE LAYOUT PLAN

245 8th STREET
 OAKLAND, CALIFORNIA

FIGURE 2
 PROJECT NO. 116907

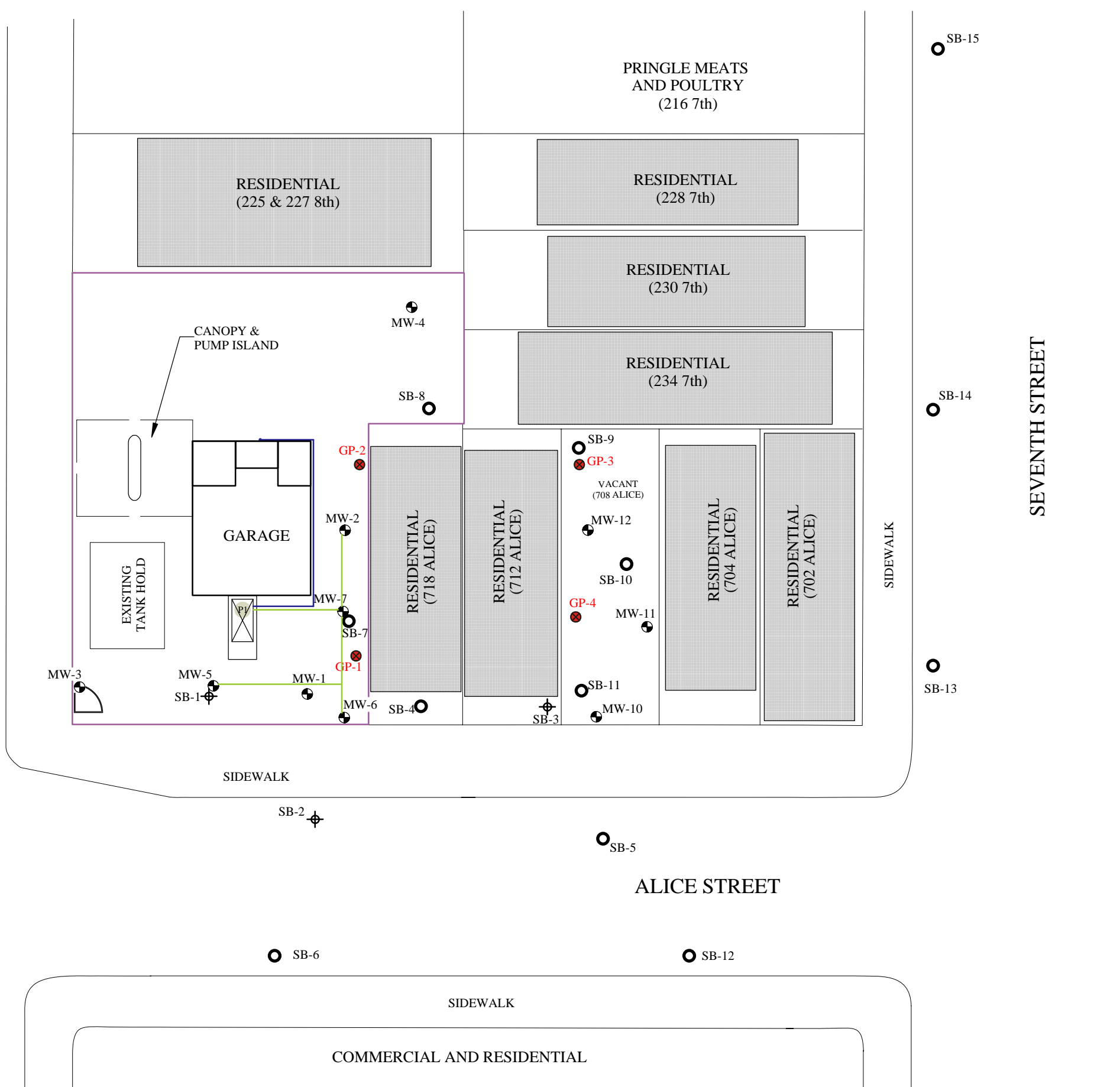
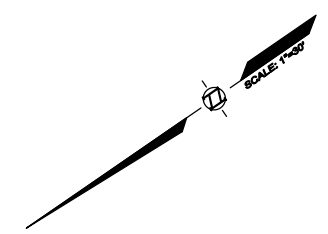

LEGEND

- SOIL BORING (8/9/96)
- SOIL BORING (4/02 & 3/03)
- MONITORING WELL
- SOIL GAS PROBE (PROPOSED)
- BUILDING FOOTPRINT
- EMISSION POINT P1
- REMEDIATION SYSTEM
- SYSTEM PIPING (2 to 2.5")
- WATER DISCHARGE PIPING (1.5")

AEI CONSULTANTS
 2500 CAMINO DIABLO, SUITE 200, WALNUT CREEK, CA

EQUIPMENT LAYOUT PLAN

245 8th STREET OAKLAND, CALIFORNIA	FIGURE 3 PROJECT NO. 116907
---------------------------------------	---------------------------------------

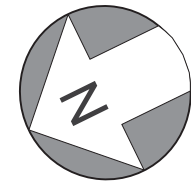

0' 10' 20' 30'
SCALE: 1 in = 30 ft

LEGEND

- MONITORING WELL
- FORMER UST LOCATION
- BUILDING FOOTPRINT

MW-10	
TPH-g	88,000
MTBE	<1,500
Benzene	6,900
Toluene	20,000
Ethylbenzene	2,300
Xylenes	9,900

Analytical
results
(ug/L)

TPH-g = Total Petroleum Hydrocarbons as gasoline
MTBE = Methyl tertiary-Butyl Ether
FP - 0.17' = Free Product - thickness (feet)

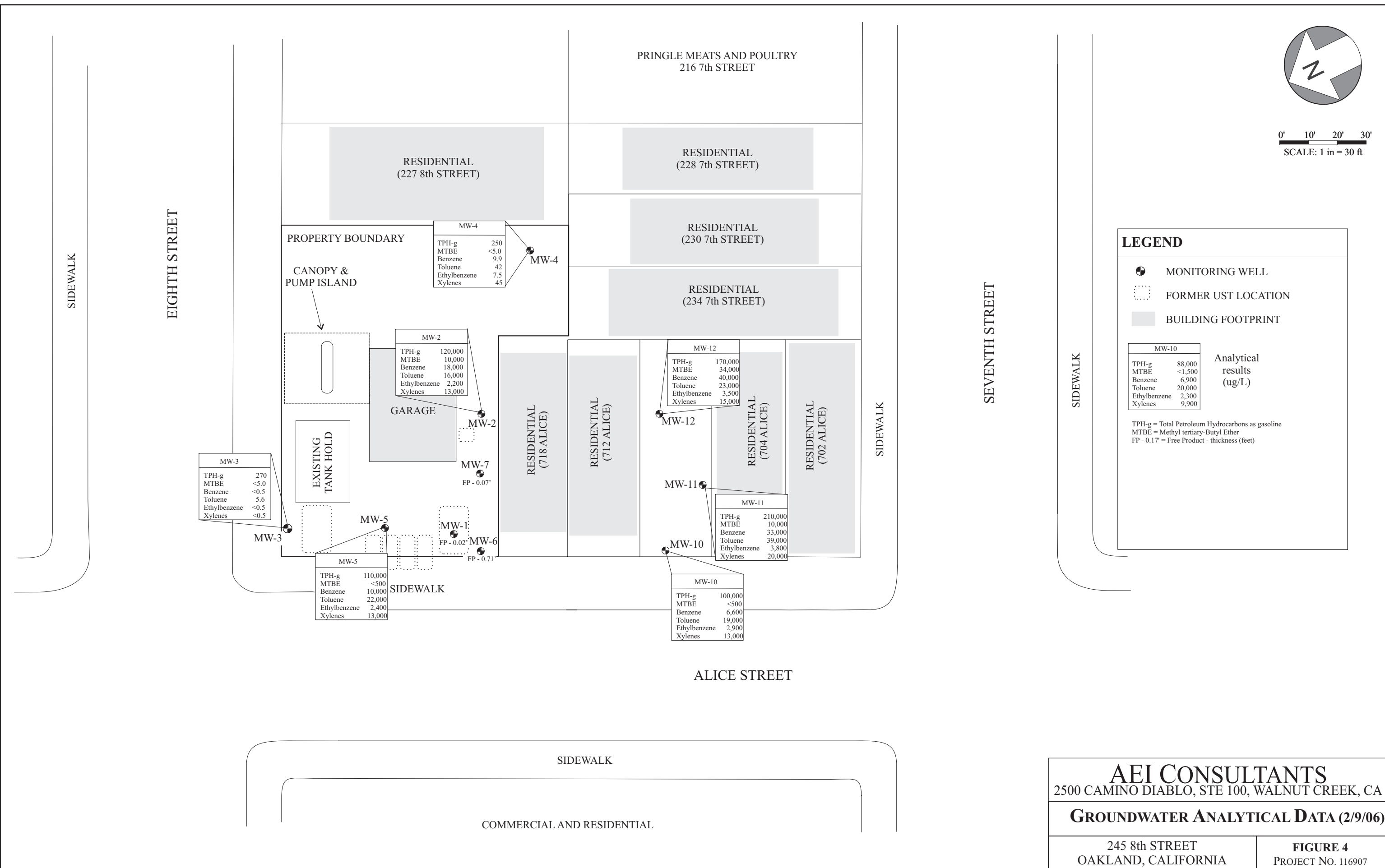

MW-4	
TPH-g	250
MTBE	<5.0
Benzene	9.9
Toluene	42
Ethylbenzene	7.5
Xylenes	45

MW-2	
TPH-g	120,000
MTBE	10,000
Benzene	18,000
Toluene	16,000
Ethylbenzene	2,200
Xylenes	13,000

MW-3	
TPH-g	270
MTBE	<5.0
Benzene	<0.5
Toluene	5.6
Ethylbenzene	<0.5
Xylenes	<0.5

MW-5	
TPH-g	110,000
MTBE	<500
Benzene	10,000
Toluene	22,000
Ethylbenzene	2,400
Xylenes	13,000

MW-12	
TPH-g	170,000
MTBE	34,000
Benzene	40,000
Toluene	23,000
Ethylbenzene	3,500
Xylenes	15,000

MW-11	
TPH-g	210,000
MTBE	10,000
Benzene	33,000
Toluene	39,000
Ethylbenzene	3,800
Xylenes	20,000

MW-10	
TPH-g	100,000
MTBE	<500
Benzene	6,600
Toluene	19,000
Ethylbenzene	2,900
Xylenes	13,000

MW-1	
FP - 0.02'	

MW-6	
FP - 0.71'	

MW-7	
FP - 0.07'	

AEI CONSULTANTS
2500 CAMINO DIABLO, STE 100, WALNUT CREEK, CA

GROUNDWATER ANALYTICAL DATA (2/9/06)

245 8th STREET OAKLAND, CALIFORNIA	FIGURE 4 PROJECT NO. 116907
---------------------------------------	---------------------------------------

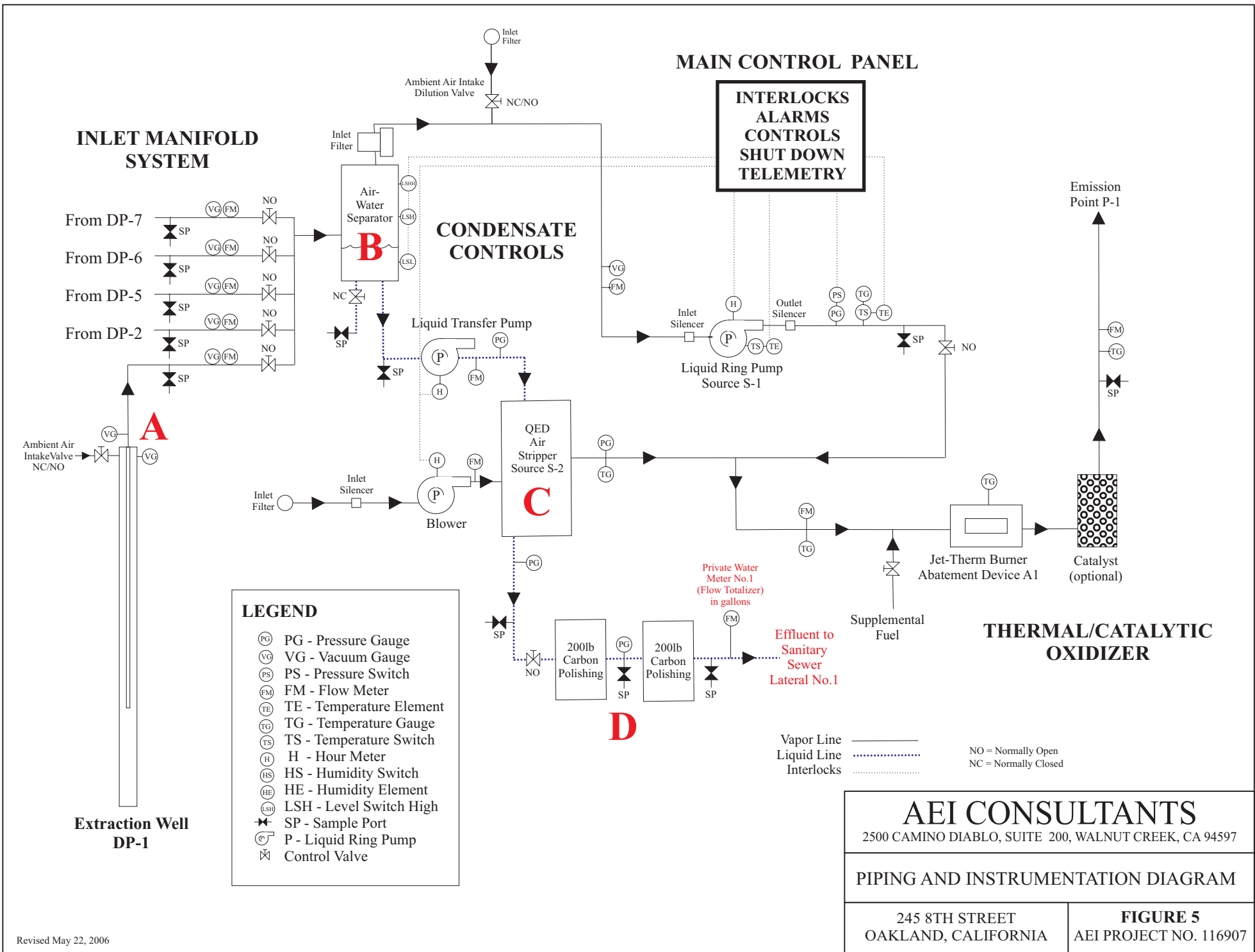

INLET MANIFOLD SYSTEM

MAIN CONTROL PANEL

CONDENSATE CONTROLS

**INTERLOCKS
ALARMS
CONTROLS
SHUT DOWN
TELEMETRY**

LEGEND

- PG - Pressure Gauge
- VG - Vacuum Gauge
- PS - Pressure Switch
- FM - Flow Meter
- TE - Temperature Element
- TG - Temperature Gauge
- TS - Temperature Switch
- H - Hour Meter
- HS - Humidity Switch
- HE - Humidity Element
- LSH - Level Switch High
- SP - Sample Port
- P - Liquid Ring Pump
- Control Valve

THERMAL/CATALYTIC OXIDIZER

AEI CONSULTANTS
 2500 CAMINO DIABLO, SUITE 200, WALNUT CREEK, CA 94597

PIPING AND INSTRUMENTATION DIAGRAM

245 8TH STREET OAKLAND, CALIFORNIA	FIGURE 5 AEI PROJECT NO. 116907
---------------------------------------	---

Revised May 22, 2006

**TYPICAL DUAL PHASE EXTRACTION
H20K TRAFFIC RATED WELL VAULT**

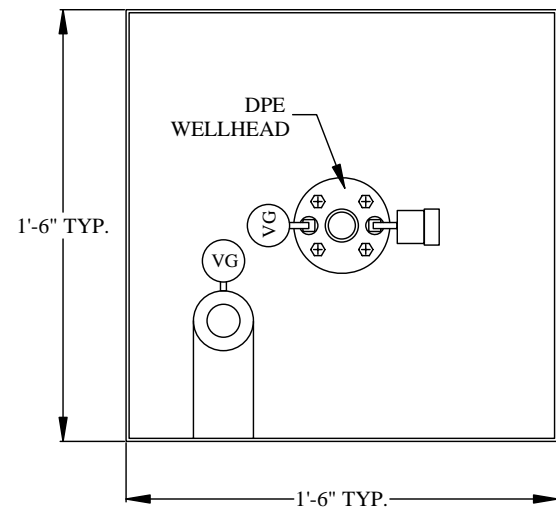

TYPICAL CONVEYANCE PIPING TRENCH

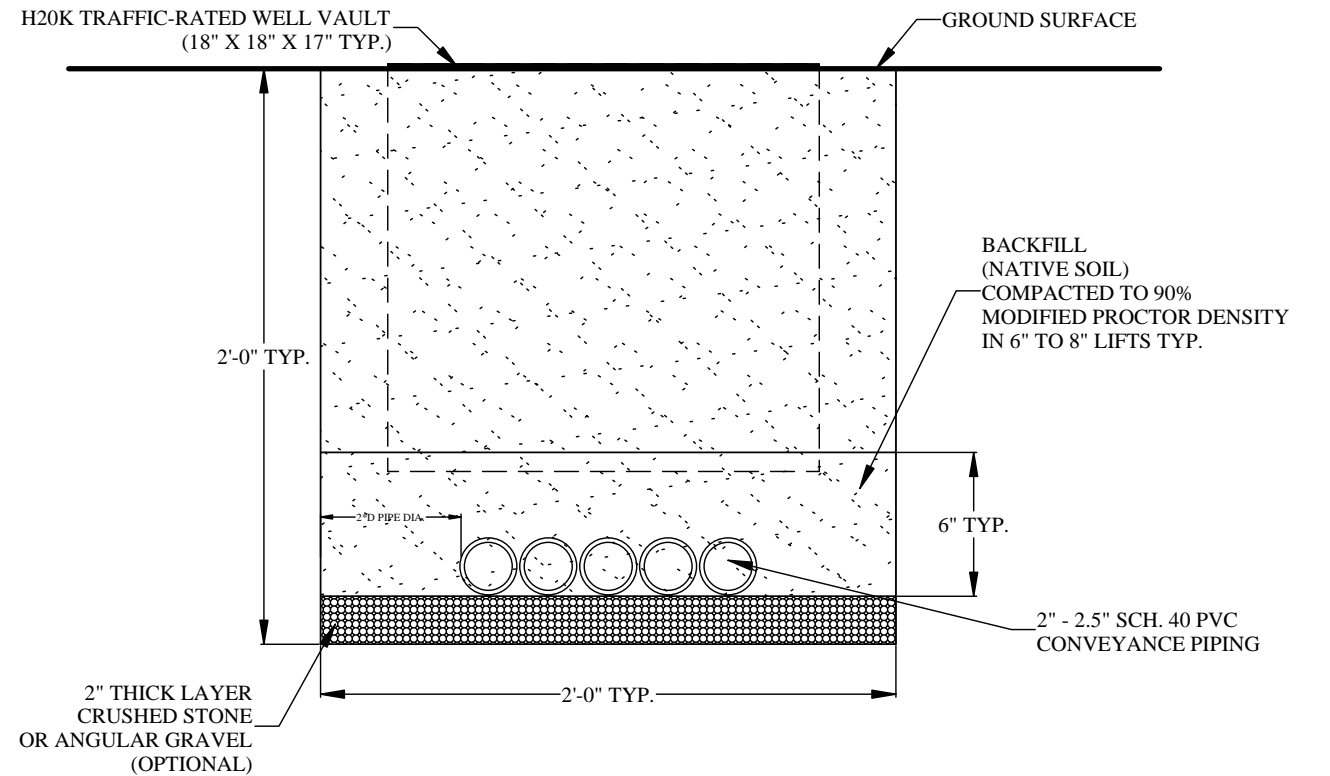

GENERAL NOTES:

- 1) 24" WIDE TYPICAL TRENCH BASED ON FIVE (5) 2" PIECES OF PVC PIPE
- 2) PIPING SHOULD BE PLACED IN THE BOTTOM OF THE TRENCH AND SPACED 1 INCHES APART
- 3) TRENCH WIDTH IS BASED ON HAVE 2 PIPE DIAMETERS ON EACH SIDE OF THE TRENCH

**TYPICAL DUAL PHASE EXTRACTION
WELLHEAD CONSTRUCTION DETAILS**

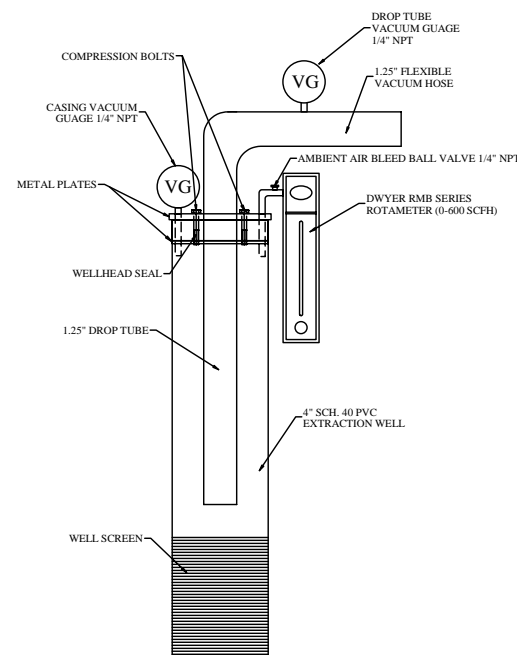
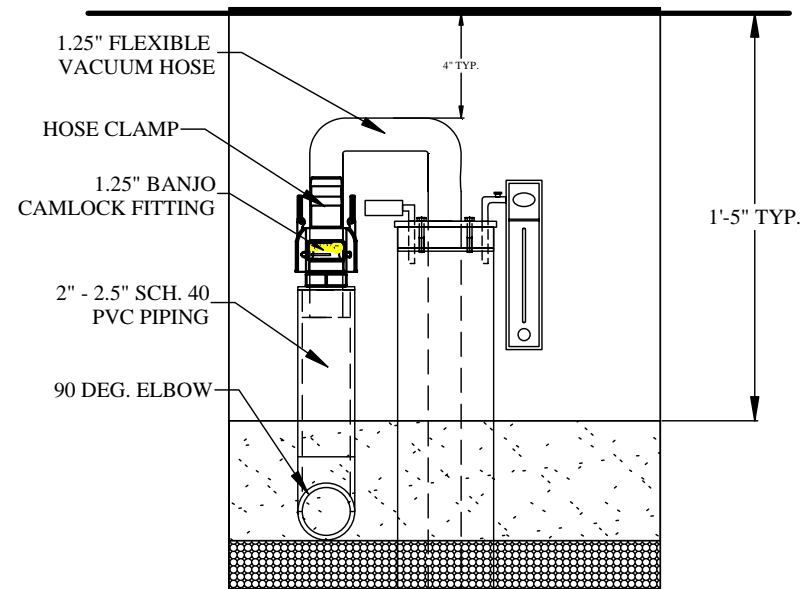

AEI CONSULTANTS	
2500 CAMINO DIABLO, SUITE 200, WALNUT CREEK, CA	
DPE WELLHEAD CONSTRUCTION DETAILS	
245 8TH STREET OAKLAND, CALIFORNIA	FIGURE 6 AEI PROJECT NO. 116907

TABLES

Table 1: Sampling Schedule Summary
Vic's Automotive, 245 8th Street, Oakland, California

Sample ID	Sampling Location	Reporting Units	TPH-g (PID calibrated w/ hexane)	TPH-g (SW8015Cm)	TPH-g (TO-3)	BTEX & MTBE (SW8021B)	VOCs (SW8260)	CO ₂ (multi gas meter)	O ₂ (multi gas meter)
<u>Vapor Sampling Locations</u>									
DP-1	DP-1 influent at manifold	ug/L and ppmv	M	Q		Q			
DP-2	DP-2 influent at manifold	ug/L and ppmv	M	Q		Q			
DP-5	DP-5 influent at manifold	ug/L and ppmv	M	Q		Q			
DP-6	DP-6 influent at manifold	ug/L and ppmv	M	Q		Q			
DP-7	DP-7 influent at manifold	ug/L and ppmv	M	Q		Q			
AS-E	Air Stripper Effluent	ug/L and ppmv	M	Q		Q			
Comb-In	Combined Influent	ug/L and ppmv	M	M		M			
Stack	Oxidizer Stack Effluent	ug/L and ppmv	M	M		M			
<u>Water Sampling Locations</u>									
AS-I	Air Stripper Influent	ug/L		M		M			
AS-E	Air Stripper Effluent	ug/L		M		M			
Mid-C	Mid-Carbon	ug/L		M		M			
Post-C	Post-Carbon	ug/L		M		M			
MWs	All Monitoring Wells	ug/L		Q		Q			
<u>Soil Gas Sampling Locations</u>									
GP-1	Rear of 718 Alice	ppmv or ppbv			Q			M	M
GP-2	Front of 718 Alice	ppmv or ppbv			Q			M	M
GP-3	Rear of 718 Alice	ppmv or ppbv			Q			M	M
GP-4	Front of 718 Alice	ppmv or ppbv			Q			M	M

M = monthly sampling
Q = quarterly sampling
SA = semi-annual sampling

ug/L = micrograms per liter

ppmv = parts per million by volume
ppbv = parts per billion by volume

Table 2: Groundwater Elevation Data
Vic's Automotive, 245 8th Ave, Oakland, CA

Well ID (screen interval)	Date Collected	TOC Well ^{1,2} Elevation (ft amsl)	Depth to Water (ft)	Groundwater ³ Elevation (ft amsl)	Depth to LNAPL (ft)	Apparent LNAPL Thickness (ft)
MW-1 (8-28)	6/29/2001	27.73	16.52	11.21	14.89	1.63
	10/10/2001	27.73	15.45	12.28	15.37	0.08
	1/9/2002	27.73	12.61	15.12	-	<0.01
	4/24/2002	27.73	13.35	14.38	-	<0.01
	7/24/2002	27.73	14.19	13.54	-	<0.01
	11/5/2002	27.73	14.85	12.88	-	<0.01
	2/4/2003	27.73	14.91	12.82	-	<0.01
	5/2/2003	27.73	14.43	13.30	-	0.08
	8/4/2003	27.73	15.24	12.49	15.01	0.23
	11/3/2003	27.73	16.94	10.79	15.67	1.27
	2/9/2004	27.73	14.61	13.12	14.43	0.18
	5/10/2004	27.73	Inaccessible	-	-	-
	8/9/2004	27.73	15.24	12.49	15.03	0.21
	11/9/2004	27.73	15.95	11.78	15.71	0.24
	2/3/2005	32.55	13.75	18.80	13.58	0.17
	5/9/2005	32.55	13.93	18.62	13.81	0.12
	8/5/2005	32.55	15.40	17.15	15.39	0.01
	11/9/2005	32.55	15.76	16.79	15.75	0.01
	2/9/2006	32.55	13.52	19.03	13.50	0.02
	MW-2 (8-28)	6/29/2001	28.16	16.14	12.02	-
10/10/2001		28.16	16.43	11.73	-	-
1/9/2002		28.16	13.50	14.66	-	-
4/24/2002		28.16	14.40	13.76	-	-
7/24/2002		28.16	14.91	13.25	-	-
11/5/2002		28.16	16.96	11.20	-	-
2/4/2003		28.16	15.42	12.74	-	-
5/2/2003		28.16	15.24	12.92	-	-
8/4/2003		28.16	15.98	12.18	-	-
11/3/2003		28.16	16.60	11.56	-	Sheen
2/9/2004		28.16	15.22	12.94	-	Sheen
5/10/2004		28.16	15.34	12.82	-	Sheen
8/9/2004		28.16	15.92	12.24	-	Sheen
11/9/2004		28.16	16.51	11.65	-	Sheen
2/3/2005		33.24	14.44	18.80	-	Sheen
5/9/2005		33.24	14.67	18.57	-	Sheen
8/5/2005		33.24	16.27	16.97	-	Sheen
11/9/2005	33.24	16.53	16.71	-	Sheen	
2/9/2006	33.24	14.36	18.88	-	Sheen	
MW-3 (10-25)	6/29/2001	29.21	16.60	12.61	-	-
	10/10/2001	29.21	16.92	12.29	-	-
	1/9/2002	29.21	14.20	15.01	-	-
	4/24/2002	29.21	15.07	14.14	-	-
	7/24/2002	29.21	16.40	12.81	-	-
	11/5/2002	29.21	16.47	12.74	-	-
	2/4/2003	29.21	16.92	12.29	-	-
	5/2/2003	29.21	15.45	13.76	-	-
	8/4/2003	29.21	16.46	12.75	-	-
	11/3/2003	29.21	17.15	12.06	-	-
	2/9/2004	29.21	15.78	13.43	-	-
	5/10/2004	29.21	15.77	13.44	-	-
	8/9/2004	29.21	16.45	12.76	-	-
	11/9/2004	29.21	17.26	11.95	-	-
	2/3/2005	34.25	15.92	18.33	-	-
	5/9/2005	34.25	15.03	19.22	-	-
	8/5/2005	34.25	16.59	17.66	-	-
11/9/2005	34.25	16.82	17.43	-	-	
2/9/2006	34.25	14.65	19.60	-	-	

Table 2: Groundwater Elevation Data
Vic's Automotive, 245 8th Ave, Oakland, CA

Well ID (screen interval)	Date Collected	TOC Well ^{1,2} Elevation (ft amsl)	Depth to Water (ft)	Groundwater ³ Elevation (ft amsl)	Depth to LNAPL (ft)	Apparent LNAPL Thickness (ft)
MW-4 (10-25)	6/29/2001	29.38	17.71	11.67	-	-
	10/10/2001	29.38	18.00	11.38	-	-
	1/9/2002	29.38	15.02	14.36	-	-
	4/24/2002	29.38	15.74	13.64	-	-
	7/24/2002	29.38	16.69	12.69	-	-
	11/5/2002	29.38	17.64	11.74	-	-
	2/4/2003	29.38	16.02	13.36	-	-
	5/2/2003	29.38	16.72	12.66	-	-
	8/4/2003	29.38	17.51	11.87	-	-
	11/3/2003	29.38	18.09	11.29	-	-
	2/9/2004	29.38	16.67	12.71	-	-
	5/10/2004	29.38	16.89	12.49	-	-
	8/9/2004	29.38	17.44	11.94	-	-
	11/9/2004	29.38	17.89	11.49	-	-
	2/3/2005	34.42	14.98	19.44	-	-
	5/9/2005	34.42	16.20	18.22	-	-
	8/5/2005	34.42	17.73	16.69	-	-
11/9/2005	34.42	17.91	16.51	-	-	
2/9/2006	34.42	15.62	18.80	-	-	
MW-5 (12-22)	2/3/2005	33.33	14.23	19.10	-	-
	5/9/2005	33.33	14.33	19.00	-	-
	8/5/2005	33.33	15.89	17.44	-	-
	11/9/2005	33.33	16.18	17.15	-	-
	2/9/2006	33.33	14.02	19.31	-	-
MW-6 (12-22)	2/3/2005	32.82	13.99	18.83	-	Sheen
	5/9/2005	32.82	13.61	19.21	-	Sheen
	8/5/2005	32.82	15.50	17.32	15.13	0.37
	11/9/2005	32.82	15.87	16.95	15.50	0.37
	2/9/2006	32.82	13.93	18.89	13.22	0.71
MW-7 (12-22)	2/3/2005	33.07	14.17	18.90	-	Sheen
	5/9/2005	33.07	14.47	18.60	14.44	0.03
	8/5/2005	33.07	16.07	17.00	16.02	0.05
	11/9/2005	33.07	16.47	16.60	16.35	0.12
	2/9/2006	33.07	14.18	18.89	14.11	0.07
MW-10 (12-22)	2/3/2005	31.17	12.65	18.52	-	-
	5/9/2005	31.17	13.09	18.08	-	-
	8/5/2005	31.17	14.68	16.49	-	-
	11/9/2005	31.17	14.94	16.23	-	-
	2/9/2006	31.17	12.82	18.35	-	-
MW-11 (12-22)	2/3/2005	31.78	13.39	18.39	-	Sheen
	5/9/2005	31.78	13.89	17.89	-	Sheen
	8/5/2005	31.78	15.47	16.31	-	Sheen
	11/9/2005	31.78	15.73	16.05	-	Sheen
	2/9/2006	31.78	13.53	18.25	-	Sheen
MW-12 (12-22)	2/3/2005	32.05	13.70	18.35	-	Sheen
	5/9/2005	32.05	14.17	17.88	-	Sheen
	8/5/2005	32.05	15.69	16.36	-	Sheen
	11/9/2005	32.05	15.93	16.12	-	Sheen
	2/9/2006	32.05	13.78	18.27	-	Sheen

1) Monitoring well top of casing (TOC) elevations were resurveyed by Morrow Surveying on January 10, 2006 and February 7, 2006

2) Groundwater elevations for the February 3, 2005 and subsequent monitoring episodes use the new well survey data

3) When LNAPL is present at >0.10 ft, the groundwater elevations are assumed to be affected by the LNAPL

All well elevations are measured from the top of the casing (TOC)

LNAPL = light non-aqueous phase liquid (floating free product)

- = not applicable

ft amsl = feet above mean sea level

Table 3: Groundwater Flow Summary
Vic's Automotive, 245 8th Ave, Oakland, CA

Episode #	Date	Average Groundwater Elevation¹ (ft msl)	Change from Previous Episode (ft)	Flow direction (gradient)
1	6/29/2001	12.10	-	SSE (0.0074)
2	10/10/2001	11.80	-0.30	SSE (0.0071)
3	1/9/2002	14.68	2.88	SE (0.0054)
4	4/24/2002	13.85	-0.83	SSW (0.005)
5	7/24/2002	12.92	-0.93	NE (0.021)
6	11/5/2002	11.89	-1.02	SW (0.019)
7	2/4/2003	12.80	0.90	NNW (0.01)
8	5/2/2003	13.11	0.32	SSE (0.01)
9	8/4/2003	12.27	-0.85	SSE(0.007)
10	11/3/2003	11.64	-0.63	SSE (0.006)
11	2/9/2004	13.03	1.39	SSE (0.006)
12	5/10/2004	12.92	-0.11	SSE (0.008)
13	8/9/2004	12.31	-0.60	SSE (0.006)
14	11/9/2004	11.70	-0.62	SSE (0.004)
15	2/3/2005	18.75	-	W (0.007)
16	5/9/2005	18.53	-0.22	S (0.010)
17	8/5/2005	16.94	-1.59	S (0.010)
18	11/9/2005	16.65	-0.28	S (0.010)
19	2/9/2006	18.83	2.17	SSW (0.010)

1) MW-2 to MW-4 only used for episodes 1 through 14; all wells used for episodes 15 and later

- = not applicable

ft msl = feet above mean sea level

Table 4: Groundwater Sample Analytical Data
Vic's Automotive, 245 8th Street, Oakland, California

Well/Sample ID	Date Collected	Apparent LNAPL Thickness (ft)	TPH-g	MTBE	Benzene	Toluene	Ethylbenzene	Xylenes
			<small>EPA Method 8015Cm</small> µg/L	µg/L	µg/L	µg/L	µg/L	
MW-1	6/29/2001	1.63	ns/fp	ns/fp	ns/fp	ns/fp	ns/fp	ns/fp
	10/10/2001	0.08	ns/fp	ns/fp	ns/fp	ns/fp	ns/fp	ns/fp
	1/9/2002	<0.01	ns/fp	ns/fp	ns/fp	ns/fp	ns/fp	ns/fp
	4/24/2002	<0.01	ns/fp	ns/fp	ns/fp	ns/fp	ns/fp	ns/fp
	7/24/2002	~0.01	ns/fp	ns/fp	ns/fp	ns/fp	ns/fp	ns/fp
	11/5/2002	~0.01	ns/fp	ns/fp	ns/fp	ns/fp	ns/fp	ns/fp
	2/4/2003	~0.01	ns/fp	ns/fp	ns/fp	ns/fp	ns/fp	ns/fp
	5/2/2003	0.08	ns/fp	ns/fp	ns/fp	ns/fp	ns/fp	ns/fp
	8/4/2003	0.23	ns/fp	ns/fp	ns/fp	ns/fp	ns/fp	ns/fp
	11/3/2003	1.27	ns/fp	ns/fp	ns/fp	ns/fp	ns/fp	ns/fp
	2/9/2004	0.18	ns/fp	ns/fp	ns/fp	ns/fp	ns/fp	ns/fp
	5/10/2004	Inaccessible	-	-	-	-	-	-
	8/9/2004	0.21	ns/fp	ns/fp	ns/fp	ns/fp	ns/fp	ns/fp
	11/9/2004	0.24	ns/fp	ns/fp	ns/fp	ns/fp	ns/fp	ns/fp
	2/3/2005	0.17	ns/fp	ns/fp	ns/fp	ns/fp	ns/fp	ns/fp
	5/9/2005	0.12	ns/fp	ns/fp	ns/fp	ns/fp	ns/fp	ns/fp
	8/5/2005	0.01	ns/fp	ns/fp	ns/fp	ns/fp	ns/fp	ns/fp
	11/9/2005	0.01	ns/fp	ns/fp	ns/fp	ns/fp	ns/fp	ns/fp
	2/9/2006	0.02	ns/fp	ns/fp	ns/fp	ns/fp	ns/fp	ns/fp
	MW-2	6/29/2001	0.0	69,000	4100/4400*	7,200	6,100	1,500
10/10/2001		0.0	87,000	14,000	22,000	12,000	2,700	9,100
1/9/2002		0.0	130,000	11,000	30,000	19,000	3,800	14,000
4/24/2002		Sheen	210,000	32,000	38,000	23,000	4,600	19,000
7/24/2002		Sheen	170,000	36,000	48,000	12,000	3,700	8,600
11/5/2002		Sheen	190,000	36,000	45,000	25,000	4,600	16,000
2/4/2003		Sheen	150,000	27,000	51,000	24,000	4,200	14,000
5/2/2003		Sheen	150,000	35,000	39,000	11,000	3,800	9,900
8/4/2003		Sheen	120,000	29,000	32,000	5,000	3,200	7,200
11/3/2003		Sheen	120,000	24,000	33,000	4,300	3,200	5,400
2/9/2004		Sheen	130,000	19,000	27,000	7,700	3,100	7,600
5/10/2004		Sheen	67,000	13,000	20,000	3,000	2,300	4,100
8/9/2004		Sheen	100,000	22,000	27,000	7,100	2,800	6,600
11/9/2004		Sheen	100,000	23,000	27,000	6,100	3,000	5,600
2/3/2005		Sheen	84,000	11,000	23,000	5,000	3,000	5,500
5/9/2005		Sheen	74,000	14,000	21,000	4,200	2,300	3,300
7/27/2005		Sheen	9,500	910	1,400	1,000	180	960
8/5/2005		Sheen	74,000	4,000	8,800	11,000	1,300	7,600
11/9/2005		Sheen	120,000	16,000	21,000	14,000	2,300	13,000
2/9/2006		Sheen	120,000	10,000	18,000	16,000	2,200	13,000
MW-3	6/29/2001	0.00	550	<5.0	<0.5	3.1	3.2	1.2
	10/10/2001	0.00	470	<5.0	0.77	5.3	3.3	5.9
	1/9/2002	0.00	1,000	<5.0	0.90	7.6	7.8	25
	4/24/2002	0.00	1,500	<5.0	0.64	7.2	12	14
	7/24/2002	0.00	1,200	<5.0	10	17.0	11	25
	11/5/2002	0.00	1,800	<25	33	43.0	18	31
	2/4/2003	0.00	450	<5.0	<0.5	5.0	<0.5	0.77
	5/2/2003	0.00	340	<5.0	7.3	10.0	2.5	7.3
	8/4/2003	0.00	170	<5.0	5.8	5.9	1.5	4.9
	11/3/2003	0.00	54	<5.0	<0.5	<0.5	<0.5	<0.5
	2/9/2004	0.00	190	<5.0	<0.5	3.6	<0.5	<0.5
	5/10/2004	0.00	280	<5.0	<0.5	3.4	<0.5	<0.5
	8/9/2004	0.00	290	<5.0	<0.5	3.8	<0.5	<0.5
	11/9/2004	0.00	220	<5.0	<0.5	4.0	<0.5	<0.5
	2/3/2005	0.00	160	<5.0	13	30	3.0	21
	5/9/2005	0.00	200	<5.0	<0.5	3.9	<0.5	<0.5
	8/5/2005	0.00	<50	<5.0	<0.5	<0.5	<0.5	<0.5
	11/9/2005	0.00	130	<5.0	<0.5	2.3	<0.5	<0.5
	2/9/2006	0.00	270	<5.0	<0.5	5.6	<0.5	<0.5

Table 4: Groundwater Sample Analytical Data
Vic's Automotive, 245 8th Street, Oakland, California

Well/Sample ID	Date Collected	Apparent LNAPL Thickness (ft)	TPH-g	MTBE	Benzene	Toluene	Ethylbenzene	Xylenes
			<small>EPA Method 8015Cm</small> µg/L	µg/L	µg/L	<small>EPA Method 8021B</small> µg/L	µg/L	µg/L
MW-4	6/29/2001	0.00	<50	<5.0	<0.5	<0.5	<0.5	<0.5
	10/10/2001	0.00	<50	<5.0	<0.5	<0.5	<0.5	<0.5
	1/9/2002	0.00	<50	<5.0	<0.5	<0.5	<0.5	<0.5
	4/24/2002	0.00	<50	<5.0	<0.5	<0.5	<0.5	<0.5
	7/24/2002	0.00	<50	<5.0	<0.5	<0.5	<0.5	<0.5
	11/5/2002	0.00	<50	<5.0	<0.5	<0.5	<0.5	<0.5
	2/4/2003	0.00	<50	<5.0	<0.5	<0.5	<0.5	<0.5
	5/2/2003	0.00	500	10	68	71	18	65
	8/4/2003	0.00	270	<5.0	30	29	9.2	32
	11/3/2003	0.00	<50	<5.0	<0.5	<0.5	<0.5	<0.5
	2/9/2004	0.00	<50	<5.0	<0.5	<0.5	<0.5	<0.5
	5/10/2004	0.00	<50	<5.0	<0.5	<0.5	<0.5	<0.5
	8/9/2004	0.00	130	<5.0	14	13	5.3	17
	11/9/2004	0.00	<50	<5.0	<0.5	<0.5	<0.5	<0.5
	2/3/2005	0.00	370	<5.0	<0.5	4.1	<0.5	0.64
	5/9/2005	0.00	840	<5.0	50	180	21	110
	7/27/2005	0.00	<50	<5.0	<0.5	<0.5	<0.5	<0.5
	8/5/2005	0.00	310	<5.0	7.5	57	10	53
	11/9/2005	0.00	290	<5.0	12	61	8.8	49
2/9/2006	0.00	250	<5.0	9.9	42	7.5	45	
MW-5	2/3/2005	0.0	78,000	<1,000	7,600	13,000	2,200	9,600
	5/9/2005	0.0	60,000	<900	6,100	9,900	1,600	6,600
	7/27/2005	nm	120,000	1,100	10,000	19,000	2,100	13,000
	8/5/2005	0.0	59,000	<500	4,100	10,000	1,200	6,600
	11/9/2005	0.0	44,000	<500	3,300	7,400	1,100	4,900
	2/9/2006	0.0	110,000	<500	10,000	22,000	2,400	13,000
MW-6	2/3/2005	Sheen	130,000	<1,000	2,400	33,000	2,400	15,000
	5/9/2005	Sheen	170,000	<4,000	11,000	43,000	3,100	16,000
	8/5/2005	0.37	ns/fp	ns/fp	ns/fp	ns/fp	ns/fp	ns/fp
	11/9/2005	0.37	ns/fp	ns/fp	ns/fp	ns/fp	ns/fp	ns/fp
	2/9/2006	0.71	ns/fp	ns/fp	ns/fp	ns/fp	ns/fp	ns/fp
MW-7	2/3/2005	Sheen	220,000	18,000	45,000	44,000	3,500	18,000
	5/9/2005	0.03	ns/fp	ns/fp	ns/fp	ns/fp	ns/fp	ns/fp
	8/5/2005	0.05	ns/fp	ns/fp	ns/fp	ns/fp	ns/fp	ns/fp
	11/9/2005	0.12	ns/fp	ns/fp	ns/fp	ns/fp	ns/fp	ns/fp
	2/9/2006	0.07	ns/fp	ns/fp	ns/fp	ns/fp	ns/fp	ns/fp
MW-10	2/3/2005	0.00	36,000	<500	4,700	7,200	660	3,400
	5/9/2005	0.00	88,000	<1,500	6,900	20,000	2,300	9,900
	8/5/2005	0.00	88,000	<1,100	10,000	21,000	1,900	9,800
	11/9/2005	0.00	63,000	<1,100	5,400	13,000	1,900	7,900
	2/9/2006	0.00	100,000	<500	6,600	19,000	2,900	13,000
MW-11	2/3/2005	Sheen	170,000	<3,000	23,000	35,000	3,100	16,000
	5/9/2005	Sheen	210,000	3,500	29,000	40,000	3,400	16,000
	7/27/2005	Sheen	220,000	2,500	26,000	37,000	3,200	18,000
	8/5/2005	Sheen	210,000	<2,500	35,000	42,000	3,300	16,000
	11/9/2005	Sheen	180,000	9,100	32,000	47,000	3,600	18,000
	2/9/2006	Sheen	210,000	10,000	33,000	39,000	3,800	20,000
MW-12	2/3/2005	Sheen	250,000	100,000	52,000	41,000	3,400	15,000
	5/9/2005	Sheen	210,000	91,000	44,000	28,000	3,300	13,000
	8/5/2005	Sheen	170,000	52,000	38,000	28,000	3,000	12,000
	11/9/2005	Sheen	180,000	52,000	39,000	25,000	2,900	12,000
	2/9/2006	Sheen	170,000	34,000	40,000	23,000	3,500	15,000

µg/L = micrograms per liter (ppb)

TPH-g = total petroleum hydrocarbons as gasoline

MTBE = methyl tertiary-butyl ether

ns/fp = not sampled / free product

* samples re-analyzed by EPA Method 8260 (expressed as EPA 8020 / EPA 8260)

Please refer to Appendix B: Lab Analytical and Chain of Custody Documentation for detailed analytical reports including dilution factors

Table 5: Groundwater Sample Analytical Data for VOCs by EPA method 8260
Vic's Automotive, 245 8th Ave, Oakland, CA

Well/Sample ID	Date Collected	DIPE µg/L	ETBE µg/L	MTBE µg/L	TAME µg/L	TBA µg/L	EDB µg/L	1,2-DCA µg/L
MW-1	7/24/02	ns/fp	ns/fp	ns/fp	ns/fp	ns/fp	ns/fp	ns/fp
MW-2	7/24/02	ND<1,000	ND<1,000	43,000	ND<1,000	ND<10,000	ND<1,000	ND<1,000
MW-3	7/24/02	ND<0.5	ND<0.5	1.3	ND<0.5	ND<5.0	ND<0.5	ND<0.5
MW-4	7/24/02	ND<0.5	ND<0.5	ND<0.5	ND<0.5	ND<5.0	ND<0.5	ND<0.5
SB-4 W	4/2/03	ND<500	ND<500	14,000	ND<500	ND<5000	ND<500	ND<500
SB-5 W	4/3/03	ND<5.0	ND<5.0	6.5	ND<5.0	790	ND<5.0	ND<5.0
SB-6 W	4/2/03	ND<0.5	ND<0.5	ND<0.5	ND<0.5	ND<5.0	ND<0.5	ND<0.5
SB-7 W	4/2/03	ND<1,200	ND>1,200	52,000	ND<1,200	ND<12,000	ND<1,200	ND<1,200
SB-8 W	4/2/03	ND<10	ND<10	480	14	ND<100	ND<10	ND<10
SB-9 W	4/3/03	ND<5.0	ND<5.0	41	ND<5.0	68	ND<5.0	ND<5.0
SB-10 W	4/3/03	ND<50	ND<50	2,800	110	ND<500	ND<50	ND<50
SB-11 W	4/3/03	ND<50	ND<50	74	ND<50	ND<500	ND<50	ND<50
SB-12 W	4/2/03	ND<0.5	ND<0.5	ND<0.5	ND<0.5	ND<5.0	ND<0.5	ND<0.5
SB-13 W	4/3/03	ND<0.5	ND<0.5	3.7	ND<0.5	ND<5.0	ND<0.5	ND<0.5
SB-14 W	4/3/03	ND<2.5	ND<2.5	180	ND<2.5	ND<25	ND<2.5	ND<2.5
SB-15 W	4/3/03	ND<0.5	ND<0.5	ND<0.5	ND<0.5	ND<5.0	ND<0.5	ND<0.5

µg/L - micrograms per liter
 ns/fp - not sampled / free product
 DIPE - Diisopropyl ether
 ETBE - Ethyl tert-butyl ether
 MTBE - Methyl tert-butyl ether

TAME - tert-Amyl methyl ether
 TBA - t-Butyl Alcohol
 EDB - 1,2-Dibromomethane
 1,2-DCA - 1,2-Dichloroethane

Please refer to laboratory analytical report for further information including the reporting limits and dilution factors

Table 6: Soil Boring Groundwater Sample Analytical Data

Vic's Automotive, 245 8th Ave., Oakland, CA

Well/Sample ID	Date Collected	TPHg µg/L	MTBE µg/L	Benzene µg/L	Toluene µg/L	Ethylbenzene µg/L	Xylenes µg/L
SB-1 W	8/18/96	140,000	480	12,000	30,000	3,900	19,000
SB-2 W	8/18/96	130,000	2,300	15,000	20,000	2,800	15,000
SB-3 W	8/18/96	120,000	27,000	19,000	29,000	1,900	9,500
SB-4 W	4/2/03	310,000	17,000	45,000	65,000	4,500	23,000
SB-5 W	4/3/03	420	ND<5.0	11	3.7	18	1.1
SB-6 W	4/2/03	210	ND<5.0	0.57	4.2	1.1	1.4
SB-7 W	4/2/03	240,000	69,000	42,000	45,000	3,100	16,000
SB-8 W	4/2/03	51	360	ND<0.5	ND<0.5	ND<0.5	ND<0.5
SB-9 W	4/3/03	7,300	ND<100	2,100	280	300	140
SB-10 W	4/3/03	210,000	ND<5000	22,000	38,000	3,400	18,000
SB-11 W	4/3/03	200,000	ND<2000	18,000	39,000	3,600	18,000
SB-12 W	4/2/03	ND<50	ND<5.0	ND<0.5	0.85	ND<0.5	0.53
SB-13 W	4/3/03	190	ND<20	ND<0.5	1.1	1.9	1.8
SB-14 W	4/3/03	ND<50	140	ND<0.5	0.95	ND<0.5	1.3
SB-15 W	4/3/03	ND<50	ND<5.0	ND<0.5	ND<0.5	ND<0.5	ND<0.5

ND - not detected

µg/L - micrograms per liter

TPHg - total petroleum hydrocarbons as gasoline

MTBE - methyl tertiary butyl ether

BTEX - Benzene, ethylbenzene, toluene, and xylenes

ns/fp - not sampled / free product

Table 7: Groundwater Sample Analytical Data: General Chemistry

Vic's Automotive, 245 8th Ave., Oakland, CA

Well/Sample ID	Date Collected	Calcium mg/L	Iron mg/L	Magnesium mg/L E200.1	Potassium mg/L	Sodium mg/L	BOD mg/L SM5210B	COD mg/L SM5220D	TOC mg/L E415.3
MW-3	02/03/05	26,000	2,300	23,000	42000	760	1.5	5	2.1
MW-4	02/03/05	10,000	1,500	11,000	360	1,100	1.5	5	1.3
MW-7	02/03/05	62,000	58,000	60,000	14000	1,100	19	510	210
MW-12	02/03/05	39,000	3,400	37,000	3600	1,100	29	680	220

Table 8: Soil Sample Analytical Data
Vic's Automotive, 245 8th Ave., Oakland, CA

Sample ID	Date Collected	TPHg mg/kg	TOG mg/kg	MTBE mg/kg	Benzene mg/kg	Toluene mg/kg	Ethylbenzene mg/kg	Xylenes mg/kg
MW-1 (6')	7/14/95	390	-	-	0.280	0.290	0.290	0.620
MW-1 (11')	7/14/95	370	-	-	0.240	0.240	0.230	0.610
MW-2 (6')	7/14/95	ND	24	-	ND	ND	ND	ND
MW-2 (11')	7/14/95	300	38	-	0.300	0.230	0.240	0.630
SB-1 (18')	8/18/96	9,100	-	47.0	57	580	190	1,000
SB-1 (24')	8/18/96	30	-	0.20	0.37	1.4	0.52	2.5
SB-2 (24')	8/18/96	1.1	-	0.032	0.11	0.17	0.018	0.099
SB-3 (24')	8/18/96	16	-	4.7	1.6	2.5	0.21	0.95
MW-3 15'	5/25/01	ND<1.0	-	ND<0.05	ND<0.005	ND<0.005	ND<0.005	ND<0.005
MW-3 20'	5/25/01	ND<1.0	-	ND<0.05	ND<0.005	ND<0.005	ND<0.005	ND<0.005
MW-4 15'	5/25/01	ND<1.0	-	ND<0.05	ND<0.005	ND<0.005	ND<0.005	ND<0.005
MW-4 20'	5/25/01	ND<1.0	-	ND<0.05	ND<0.005	ND<0.005	ND<0.005	ND<0.005
SB-4 12'	4/2/03	25	-	ND<0.5	0.41	1.0	0.2	1.3
SB-4 15'	4/2/03	260	-	ND<1.7	3.5	15	4.5	23
SB-5 11'	4/3/03	ND<1.0	-	ND<0.05	ND<0.005	ND<0.005	ND<0.005	ND<0.005
SB-6 16'	4/2/03	ND<1.0	-	ND<0.05	ND<0.005	ND<0.005	ND<0.005	ND<0.005
SB-7 12'	4/2/03	700	-	ND<10	6.0	25	9.3	50
SB-7 18'	4/2/03	4,900	-	ND<25	65	260	77	400
SB-8 17'	4/2/03	ND<1.0	-	ND<0.05	ND<0.005	ND<0.005	ND<0.005	ND<0.005
SB-9 16'	4/3/03	ND<1.0	-	ND<0.05	ND<0.005	ND<0.005	ND<0.005	ND<0.005
SB-10 12'	4/3/03	ND<1.0	-	ND<0.05	ND<0.005	ND<0.005	ND<0.005	ND<0.005
SB-11 12'	4/3/03	1.4	-	ND<0.05	0.12	0.10	0.026	0.066
SB-11 16'	4/3/03	2,700	-	ND<30	29	170	49.0	250
SB-12 15'	4/2/03	ND<1.0	-	ND<0.05	ND<0.005	ND<0.005	ND<0.005	ND<0.005
SB-13 14'	4/3/03	ND<1.0	-	ND<0.05	ND<0.005	ND<0.005	ND<0.005	ND<0.005
SB-14 14'	4/3/03	ND<1.0	-	ND<0.05	ND<0.005	ND<0.005	ND<0.005	ND<0.005
SB-15 14'	4/3/03	ND<1.0	-	ND<0.05	ND<0.005	ND<0.005	ND<0.005	ND<0.005
MW-5 16'	1/11/2005	100	-	ND<5.0	2.6	6.0	1.5	8.4
MW-5 20'	1/11/2005	37	-	ND<0.50	2.6	5.6	0.91	4.6
MW-7 16'	1/11/2005	19	-	2.9	3.3	3.5	0.4	1.9
MW-7 20.5'	1/11/2005	340	-	ND<5.0	9.6	25	7.0	35
MW-6 20'	1/19/2005	14	-	ND<0.25	0.099	4.1	0.33	1.7
MW-10 15.5'	1/20/2005	840	-	ND<2.0	11	58	16	83
MW-11 15.5'	1/19/2005	3,200	-	ND<10	35	320	85	430
MW-12 15.5'	1/19/2005	13	-	8.5	2.5	2.8	0.22	1.1

ND - not detected

mg/kg - milligrams per kilogram

TPHg - total petroleum hydrocarbons as gasoline

MTBE - methy tertiary butyl ether

TOG - Total Oil and Grease

Table 9: Soil Vapor Sample Analytical Data
Vic's Automotive, 245 8th Ave., Oakland, CA

Sample ID	Date	TPHg	MTBE	Benzene	Toluene	Ethylbenzene	Xylenes
	Collected	$\mu\text{g/L}$	$\mu\text{g/L}$	$\mu\text{g/L}$	$\mu\text{g/L}$	$\mu\text{g/L}$	$\mu\text{g/L}$
SB-4 4' V	4/2/03	ND<25	ND<2.5	ND<0.25	ND<0.25	ND<0.25	ND<0.25
SB-7 4' V	4/2/03	ND<25	ND<2.5	ND<0.25	ND<0.25	ND<0.25	ND<0.25
SB-8 4' V	4/2/03	ND<25	ND<2.5	ND<0.25	ND<0.25	ND<0.25	ND<0.25
SB-16 4' V	4/2/03	ND<25	ND<2.5	ND<0.25	ND<0.25	ND<0.25	ND<0.25
SB-17 4' V	4/2/03	ND<25	ND<2.5	ND<0.25	ND<0.25	ND<0.25	ND<0.25

ND - not detected

$\mu\text{g/L}$ - micrograms per liter

TPHg - total petroleum hydrocarbons as gasoline

MTBE - methyl tertiary butyl ether

Please refer to Laboratory Analytical Data for further detailed lab information including lab reporting limits and dilution factors

Table 10: Extraction Event Vapor Sample Data (TPH-g)
 Vic's Automotive, 245 8th Ave., Oakland, CA

Date & Time	MW-1	MW-2	MW-5	MW-6	MW-7	Combined
7/11/05 12:00	60,000	-	-	46,000	53,000	69,000
7/12/05 0:00	-	-	-	-	-	33,000
7/12/05 8:00	33,000	-	-	16,000	33,000	-
7/12/05 9:00	-	58,000	20,000	-	-	61,000
7/14/05 9:30	24,000	37,000	53,000	18,000	52,000	49,000
7/14/05 21:00	-	-	-	-	-	35,000
7/15/05 9:00	25,000	32,000	27,000	21,000	55,000	47,000
7/19/05 7:30	3,100	6,500	14,000	17,000	58,000	38,000
7/22/05 12:45	17,000	15,000	16,000	14,000	53,000	38,000
7/27/05 11:30	16,000	18,000	12,000	25,000	58,000	43,000

All data in micrograms per liter of air (µg/L)

Refer to analytical reports for BTEX & MTBE data