

RECEIVED

By Alameda County Environmental Health at 1:59 pm, Jul 29, 2013

Mr. Lee Douglas
Douglas Parking Company
1721 Webster Street
Oakland, California 94612

Ms. Barbara Jakub
Alameda County Environmental Health
Department of Environmental Health
1131 Harbor Bay Parkway, 2nd Floor
Alameda, CA 94502-6577

Re: Douglas Parking Company
1721 Webster Street
Oakland, California
ACEH File No. 129

Dear Ms. Jakub:

I, Mr. Lee Douglas, have retained Pangea Environmental Services, Inc. (Pangea) as the environmental consultant for the project referenced above. Pangea is submitting the attached report on my behalf.

I declare, under penalty of perjury, that the information and/or recommendations contained in the attached report are true and correct to the best of my knowledge.

Sincerely,

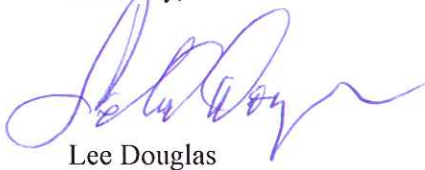

Lee Douglas



July 25, 2013

VIA ALAMEDA COUNTY FTP SITE

Ms. Barbara Jakub
Alameda County Environmental Health
1131 Harbor Bay Parkway, 2nd Floor
Alameda, California 94502

Re: **Revised Data Gap Workplan**
Douglas Parking Company
1721 Webster Street
Oakland, California
ACEH File No. 129

Dear Ms. Jakub:

On behalf of Douglas Parking Company, Pangea Environmental Services, Inc. (Pangea) has prepared this *Revised Data Gap Workplan* (Workplan). This Workplan was requested by an Alameda County Environmental Health (ACEH) email dated May 28, 2013. The Workplan was requested to address remaining data gaps identified in the May 28, 2013 meeting with Dilan Roe and Barbara Jakub of ACEH. The purpose of the investigation is to evaluate site conditions compared to the Low Threat Closure Policy (LTCP) criteria adopted by the State Water Resources Control Board (SWRCB).

If you have any questions or comments, please call me at (510) 435-8664.

Sincerely,
Pangea Environmental Services, Inc.

A handwritten signature in blue ink that reads "Bob Clark-Riddell".

Bob Clark-Riddell, P.E.
Principal Engineer

Attachment: *Revised Data Gap Workplan*

cc: Mr. Lee Douglas, Douglas Parking Company, 1721 Webster Street, Oakland, California 94612
SWRCB Geotracker Database (electronic copy)

PANGEA Environmental Services, Inc.

1710 Franklin Street, Suite 200, Oakland, CA 94612 Telephone 510.836.3700 Facsimile 510.836.3709 www.pangeaenv.com



REVISED DATA GAP WORKPLAN

**Douglas Parking Company
1721 Webster Street
Oakland, California
ACEH File No. 129**

July 25, 2013

Prepared for:

Mr. Lee Douglas
1721 Webster Street
Oakland, California 94612

Prepared by:

Pangea Environmental Services, Inc.
1710 Franklin Street, Suite 200
Oakland, California 94612

Written by:

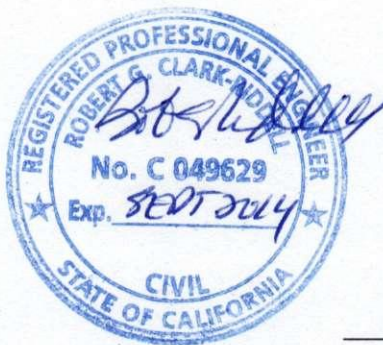

Morgan Gillies
Project Manager

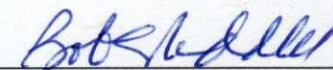
Bob Clark-Riddell, P.E.
Principal Engineer

PANGEA Environmental Services, Inc.

1710 Franklin Street, Suite 200, Oakland, CA 94612 Telephone 510.836.3700 Facsimile 510.836.3709 www.pangeaenv.com

INTRODUCTION

On behalf of Douglas Parking Company, Pangea Environmental Services, Inc. (Pangea) has prepared this *Revised Data Gap Workplan* (Workplan). This Workplan was requested by an Alameda County Environmental Health (ACEH) email dated May 28, 2013 (Appendix A). The Workplan was requested to address data gaps indentified in a meeting with ACEH on May 28, 2013. Consistent with the ACEH email, Pangea proposes soil gas sampling and soil borings near the former USTs to evaluate potential vapor intrusion into nearby buildings and shallow source area soil conditions. The purpose of the investigation is to evaluate site conditions compared to the Low Threat Closure Policy (LTCP) criteria adopted by the State Water Resources Control Board (SWRCB).

SITE BACKGROUND

Site Description

The site is currently being utilized as a parking garage, and is located between 17th and 19th Streets in downtown Oakland, California, approximately four miles east of San Francisco Bay and one quarter mile west of Lake Merritt (Figure 1). The site is relatively flat with an elevation of approximately 30 feet (ft) above mean sea level (msl).

Several former underground storage tank (UST) sites are located close to the site, including Prentiss Properties to the northeast at 1750 Webster Street, a former gas station to the east at 1700 Webster, and a former Chevron service station which is located approximately 400 feet to the southwest on the corner of 17th Street and Harrison Street.

On August 3 and 6, 1992, Parker Environmental Services removed one 1,000-gallon and two 500-gallon gasoline underground storage tanks (USTs) from the site. Up to 1,500 milligrams per kilogram (mg/kg) total petroleum hydrocarbons as gasoline (TPHg) and up to 12 mg/kg benzene were detected in the soil samples collected from the UST excavation.

Several investigations have been completed at the site. On July 8 and September 8, 1994, Gen Tech/Piers Environmental, Inc. (Gen Tech) of San Jose, California drilled six exploratory borings and installed three groundwater monitoring wells (MW-1 through MW-3). In February and May 1996, Cambria Environmental Technology (Cambria) of Emeryville, California advanced seven geoprobe soil borings and installed two groundwater monitoring wells (MW-4 and MW-5). On August 8, 2000, *Conduit Study and File Review Report* was submitted by Cambria Environmental Technology. The report provided significant information about offsite hydrocarbon impact and offsite sources, and concluded that there were no identified conduits for

contaminant migration in groundwater. On June 27, 2003 Cambria installed two additional offsite monitoring wells (MW-6 and MW-7) to facilitate additional plume delineation.

Limited site remediation has been conducted at the site. In January 1998, Cambria installed ORC socks in well MW-2 to enhance the natural attenuation of dissolved-phase hydrocarbons. Dissolved oxygen (DO) concentrations temporarily increased in well MW-2 following the ORC sock installation. In February and March 1999, a total of 120 gallons of 7.5% hydrogen peroxide solution was added into monitoring wells MW-2 and MW-3 to oxidize hydrocarbons and also increase DO levels to enhance biodegradation of dissolved-phase hydrocarbons. The hydrogen peroxide *temporarily* increased groundwater DO levels, but hydrocarbon concentrations remained at elevated levels.

On March 4, 2003, Cambria installed a co-axial air sparging/soil vapor extraction well (SV-1/AS-1) and two angled air sparging wells (AS-2 and AS-3) to approximately 30 ft below grade surface (bgs). The wells were installed to facilitate feasibility testing and future site remediation. Site remediation via soil vapor extraction and air sparging began in October 2007. To improve system performance and further evaluate site conditions, Pangea submitted an *Investigation and Remediation Workplan* dated March 5, 2009, which proposed additional investigation, remediation system expansion, and evaluation of groundwater geochemistry.

On November 19, 2010, ACEH issued a letter requesting a cross section, additional information regarding a potential offsite source and a preferential pathway survey. In December 2010, Pangea informed the ACEH that significant information about the offsite hydrocarbon impact was presented in the August 8, 2000 *Conduit Study and File Review Report* prepared by Cambria. In December 2010, the UST Cleanup Fund prepared a 5 Year Review that recommended a site conceptual model (SCM), risk assessment, and sensitive receptor survey to help facilitate selection of an enhanced remediation technique. In a letter dated June 17, 2011, ACEH requested a site conceptual model with a preferential pathway evaluation. Pangea submitted a *Sensitive Receptor Survey, Conduit Study and Site Conceptual Model* (SCM) dated March 26, 2012. In a letter dated December 21, 2012, ACEH requested a workplan for vapor intrusion evaluation and investigation of potential secondary source near well MW-2. Pangea submitted the requested *Workplan for Additional Assessment and Soil Gas Sampling* on April 4, 2013. In a meeting on May 28, 2013, ACEH identified media-specific criteria data gaps related to the State Water Resources Control Board's Low Threat Closure Policy. Following the meeting, ACEH requested a revised workplan to address these data gaps.

Site Geology & Hydrogeology

Unconfined groundwater conditions exist at the site. A shallow water-bearing zone consisting of highly permeable sand is present from approximately 14 to 30 feet bgs, and is underlain by a silty clay layer. Groundwater beneath the site generally flows *northwards* to *north-northeastwards*, consistent with the local

topography. Since 1994, the depth to groundwater beneath and surrounding the site has ranged from approximately 13.6 feet bgs (MW-5) to 23.4 feet bgs (MW-7), equivalent to a groundwater elevation range from 5 to 13 feet above msl over thirteen years of monitoring. For source area well MW-2, groundwater depth has fluctuated only three feet, from 17.8 to 20.8 ft bgs (hydrocarbon concentrations generally decrease during low groundwater depth in well MW-2).

Contaminant Distribution in Soil

Based on previous site investigations, the extent of detected TPHg and benzene concentrations in soil is primarily limited to the area around the former site USTs. Generally, the highest concentrations of contaminants in soil were detected during tank removal activities in August 1992, when shallow soil samples were collected at depths ranging from 7 to 14 ft bgs. Additional soil samples were collected in July 1994 and February and May 1996 at depths ranging from 15.5 to 31 ft bgs. The deeper soil samples, collected in 1994 and 1996, contained very low to non-detect concentrations of contaminants in the immediate area around the former site USTs. Historical soil analytical results are included in Table 1.

Contaminant Distribution in Groundwater

The lateral extent of contaminants in shallow groundwater appears to be fairly well defined by data from existing monitoring wells and historical grab groundwater sampling. The downgradient extent of TPHg and benzene contamination in groundwater is defined by monitoring well MW-5. Contaminant concentrations are generally highest in source wells MW-2 and MW-3, which are both located near the former USTs, and in offsite wells MW-4 and MW-6 located down/crossgradient from the source area. Hydrocarbons in wells MW-4 and MW-6 located across the street may be from an offsite source. Groundwater analytical data indicates that the contaminant plume is stable.

Some vertical assessment of contamination in groundwater at 1721 Webster Street is provided by air sparge wells screened at approximately 27 to 30 ft bgs. Most site monitoring wells are screened between 15 and 30 feet bgs. There is a layer of clay at approximately 30 ft bgs near the former USTs. This clay layer may be preventing contaminants from migrating into deeper water-bearing zones. Groundwater analytical data from the deeper site wells (air sparge wells) suggests that hydrocarbons are mostly limited to shallower groundwater.

PROPOSED INVESTIGATION

The objective of the proposed investigation is to evaluate the potential for vapor intrusion into indoor air for the onsite and adjacent retail buildings, and to evaluate contaminant concentrations in shallow source area soil near previously collected UST confirmation samples. The purpose of the investigation is to evaluate site

conditions compared to the Low Threat Closure Policy (LTCP) criteria issued by the State Water Resources Control Board (SWRCB). The proposed scope of work to accomplish the investigation objectives is detailed below.

Task 1 - Pre-Field Activities

Prior to initiating field activities, Pangea will conduct the following tasks:

- Obtain encroachment and excavation permits from the City of Oakland and drilling permits from Alameda County Public Works Agency (ACPWA) as necessary;
- Pre-mark the boring locations with white paint, notify Underground Service Alert (USA) of the drilling and sampling activities at least 72 hours before work begins, and conduct private line locating as merited;
- Prepare a site-specific health and safety plan to educate personnel and minimize their exposure to potential hazards related to site activities; and
- Coordinate with drilling and laboratory subcontractors and other involved parties.

Task 2 – Soil Borings

To evaluate current contaminant concentrations in soil near the former USTs, Pangea proposes to advance two confirmation soil borings. As shown on Figure 2, Pangea proposes to advance boring CB-1 near the northern end of the former southern UST to evaluate current soil conditions in close proximity to UST excavation confirmation samples T6, T4, and SW1. Confirmation boring CB-2 is proposed near the southern end of the former northern UST in close proximity to confirmation sample T1. Pangea proposes advancing borings CB-1 and CB-2 to approximately 15 and 10 ft bgs, respectively. Soil samples collected from these borings will also help evaluate direct contact and outdoor air criteria of the LTCP. Please note boring locations may be adjusted in the field if the primary material encountered in the upper 10 ft is former UST excavation backfill material. At each boring location, soil samples will be collected every four feet. Groundwater sampling is not proposed at either boring location.

Pangea will conduct site investigation using hand auger and/or a direct-push sampling rig. If a direct-push sampling rig is used, all borings will first be hand augered to five feet due to subsurface utilities. The direct-push sampling rig will be equipped with a hydraulic hammer and steel drive rods to advance the borings to the proposed total depth. With hydraulic-push drilling, continuous soil collection is conducted using acetate liners and samples are typically collected on four foot intervals. Soil samples will be obtained by cutting 6-inch

subsections, trimming the excess soil from the ends, and capping the ends with Teflon[®] tape and plastic caps. If hand auger techniques are used, soil samples will be collected within new brass or stainless steel liners driven into undisturbed soil with a slide-hammer. Additional soil samples may be collected at lithologic changes. The soil will be classified according to the Unified Soil Classification System (USCS) and screened for field indications of petroleum hydrocarbons using visual and olfactory observations and a photo-ionization detector (PID).

All site investigation activities will be performed under the supervision of a California Registered Civil Professional Engineer (P.E.). Additional soil and assessment procedures are presented in our Standard Operating Procedures (SOPs) in Appendix B.

Soil samples will be analyzed for total petroleum hydrocarbons as gasoline (TPHg), benzene, toluene, ethylbenzene, xylenes (BTEX), and methyl-tertiary butyl ether (MTBE) by EPA Method 8015Cm/8021B.

Task 3 –Subslab Sampling

Pangea proposes to install three (3) subslab probes to facilitate collection of subslab gas samples. Pangea proposes subslab gas sampling to more thoroughly evaluate subsurface vapor conditions because hydrocarbon vapors could migrate through underground conduits to below the concrete slab, without significantly impacting deeper soil. Semi-permanent probes will be used to allow subsequent collection if merited. Pangea anticipates collecting initial subslab gas samples during the dry season. If requested by ACEH, additional subslab gas samples can be collected during the wet season.

The proposed sampling locations were selected to minimize disruption to existing businesses, while meeting the investigation objectives. As shown on Figure 2, all three subslab probe locations (SS-1 through SS-3) are within the onsite and adjacent retail buildings. Subslab gas samples will be collected within sorbent tubes and/or Summa canisters and submitted to a state-certified laboratory for analysis. All subslab gas samples will be analyzed for total petroleum hydrocarbons as gasoline (TPHg), benzene, toluene, ethylbenzene, xylene(s) (BTEX), methyl-tertiary butyl ether (MTBE) and naphthalene by Total Organics Method 15 (TO-15), and subslab gas from probe SS-1 will be analyzed for naphthalene by modified Total Organics Method 17 (TO-17). Consistent with the *April 2012 Cal/EPA Advisory – Active Soil Gas Investigations*, Pangea plans to confirm analysis by TO-15 for naphthalene with TO-17 from probe SS-1. Additionally, for naphthalene analysis by TO-15, the analytical laboratory will utilize procedures for recovery, carryover, canister cleanliness, age, and matrix spikes and matrix spike duplicates as outlined in the *April 2012 Cal/EPA Advisory Appendix E*. Subslab gas samples will also be analyzed for percent oxygen and helium (leak check compound) by Method ASTM D-1946. The oxygen analyses will help evaluate the potential for future degradation and attenuation of

detected hydrocarbons, and will help assess soil column characteristics ($\geq 4\%$ oxygen in soil gas is referenced in the SWRCB's Underground Storage Tank Low-Threat Site Closure Policy).

The *subslab* gas probe installation procedure involves using a rotohammer to drill a 1 ½-inch diameter, 4-inch deep hole in the approximately 6-inch thick concrete slab of the building, drilling a ½-inch diameter hole through the remaining concrete, installing a rubber stopper with stainless steel tubing (capped on one end with a Swagelok fitting) and placing a bentonite and cement seal from the top of the stopper to within an inch of the surface. For probe SS-1 (located indoors) a protective plastic cap will be placed over the top of the probe to protect it. For probes SS-2 and SS-3 (located in the indoor garage) small diameter well boxes will be installed over the top of the probes for protection. The probes will be allowed to equilibrate for at least 2 hours, prior to sampling. A schematic of the subslab probe construction is shown in the SOPs in Appendix B.

Summa Canister Sample Collection for Method TO-15 Analysis

An analytical laboratory will provide sampling assemblies and certified Summa canisters for sampling. The Summa canisters will come under a complete vacuum of approximately 30 inches of mercury. Prior to sample collection a shut in test will be conducted on the sampling assembly with a vacuum pump to confirm no leak and the maintenance of the initial vacuum in the sampling manifold system. After shut in testing, the probe will be connected to the sampling assembly using a Swagelok fitting and Teflon tubing, then a shroud will be placed over the probe and Helium will be introduced to a concentration of 20 to 30%. The helium concentration will be monitored periodically using a helium detector and the vacuum pump will be started to purge the manifold/probe assembly. During purging, vapor from the probe will be routed to a Tedlar bag within a vacuum chamber to check for helium within the probe/sampling assembly and to qualitatively screen for volatile contaminants using a PID. Upon completion of purging of approximately three times the ambient volume of air in the assembly/probe and void space, the sampling Summa canister will be opened for sample collection. The pre-set valve will regulate the vapor flow to approximately 150 milliliters of air per minute, which equates to approximately 5 minutes to fill the 1-liter canister. Sample collection is typically discontinued when the vacuum decreases to between 5 and 4 inches of mercury. For further quality assurance, a duplicate sample will be collected at each sampling event.

Additionally, Tedlar bag samples are collected after sample collection to check for helium in the sampling assembly. This method allows Pangea to monitor for leaks from the sample probe before and after sample collection and correct problems before sending the samples to the laboratory. The subslab sampling will be conducted in general accordance with procedures described in Pangea's Standard Operating Procedures (SOPs) for Subslab Gas Sampling (Appendix B).

Sorbent Tube Sampling for Method TO-17 Analysis

A sorbent tube will be used to sample probe SS-1 for naphthalene using Method TO-17. An analytical laboratory will provide conditioned sorbent tubes for the Method TO-17 sampling. The laboratory will also provide back-up tubes and field blanks. Teflon tubing with Swagelok fittings on each end will be used to attach the soil gas probe to the sorbent tube.

Following TO-15 sampling from probe SS-1, which will effectively purge the probe prior to TO-17 sampling, an air pump with a mass flow monitor will be placed in line after a "dummy" tube. The approximate sample flow rate of 50 mL/min will be established and recorded on a field test sheet (FTS). The "dummy" tube will be replaced with the sample tube after establishing the appropriate flow rate for one minute. Air pumping will continue for approximately 20 minutes for the one liter sample and the flow rate will be checked prior to discontinuing pumping. After turning off the pump, the sample sorbent tube will be removed, capped on both ends and stored in sealable plastic bags on ice in an ice chest. Sorbent tube identification numbers, pump flow rates, sample times and volume will be submitted to the state-certified laboratory along with the samples.

Task 4 – Waste Management and Disposal

Soil cuttings and other investigation-derived waste will be stored onsite in Department of Transportation (DOT)-approved 55-gallon drums. The drums and their contents will be held onsite pending laboratory analytical results. Upon receipt of the analytical reports, the waste will be transported to an appropriate disposal/recycling facility.

Task 5 – Report Preparation

Upon completion of assessment activities, Pangea will prepare a technical report. The report will describe the investigation activities, present tabulated analytical data, and offer conclusions and recommendations.

REFERENCES

- Cambria Environmental Technology, Inc., 2004, *Feasibility Test Report*, Douglas Parking Company, 1721 Webster Street, Oakland, California, April 22.
- Cal/EPA, 2012, *Advisory-Active Soil Gas Investigation*, California Environmental Protection Agency, Department of Toxic Substances Control, Los Angeles Regional Water Quality Control Board, San Francisco Regional Water Quality Control Board, April.

ATTACHMENTS

Figure 1 – Vicinity Map

Figure 2 – Proposed Boring and Subslab Gas Probe Location Map

Table 1 – Soil Analytical Data

Table 2 – Groundwater Analytical Data

Appendix A – Regulatory Correspondence

Appendix B – Standard Operating Procedures

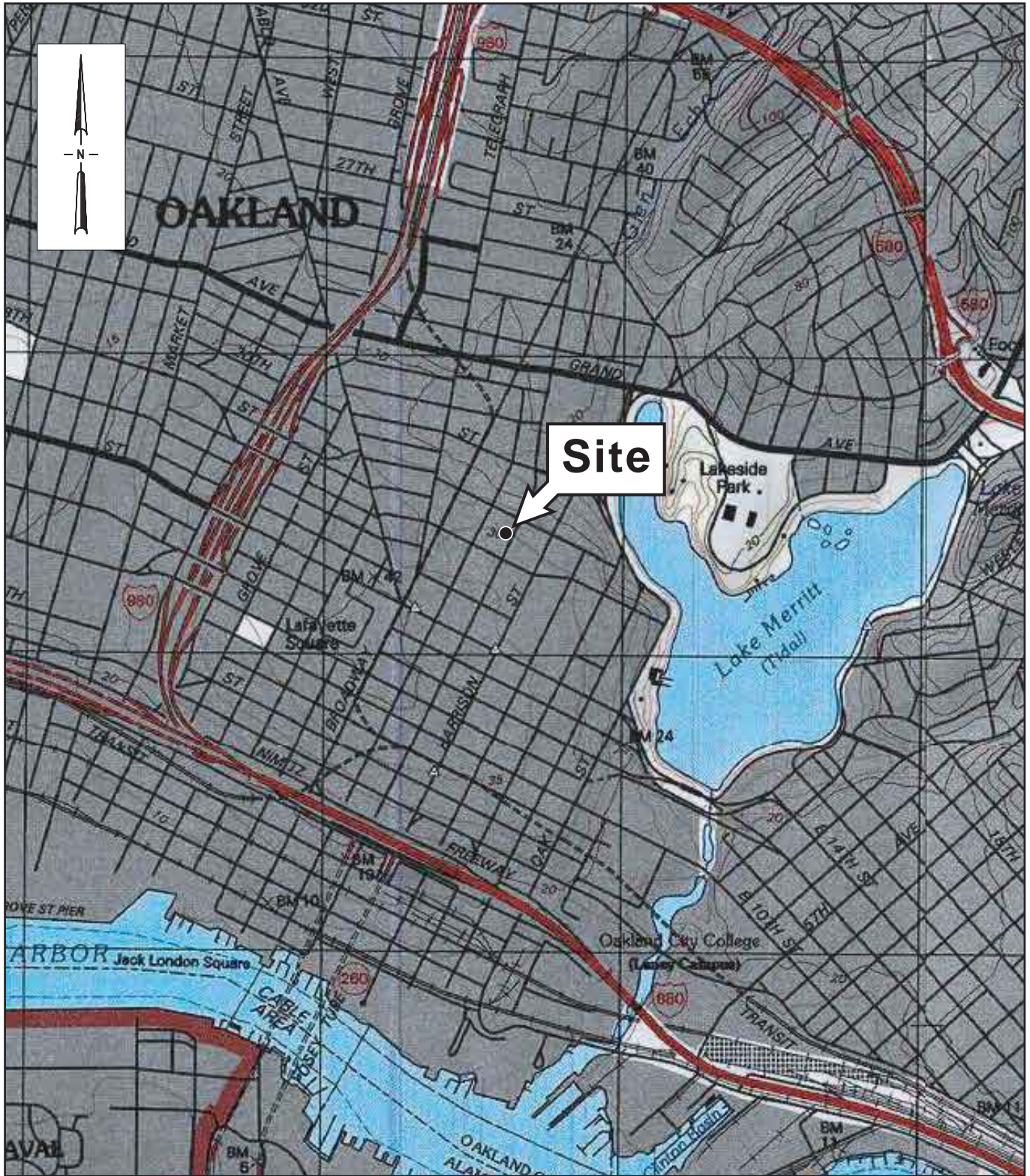

SOURCE: TOPOI MAPS

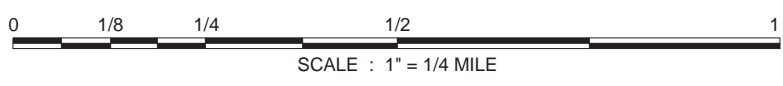
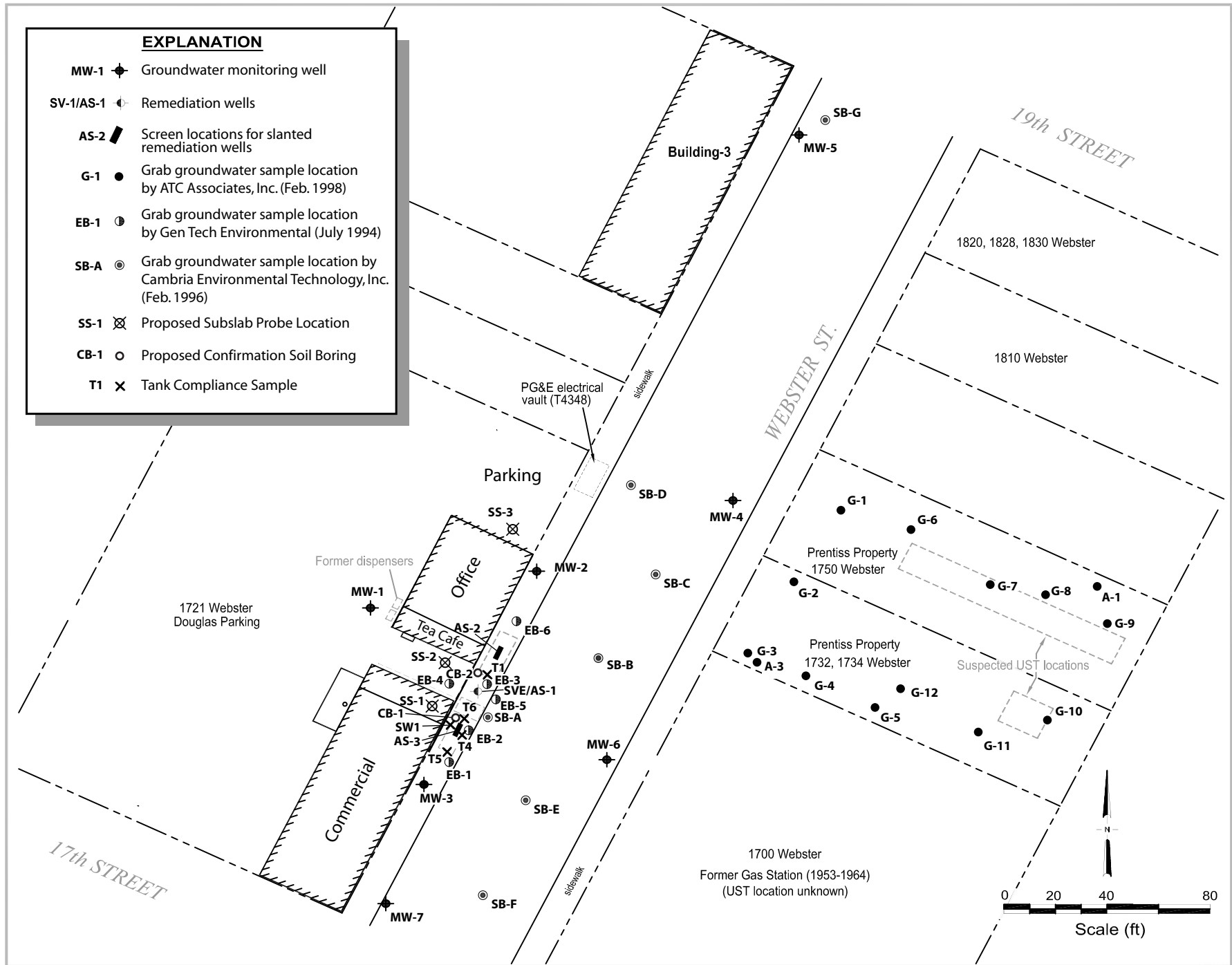

Figure 1

Douglas Parking Facility
 1721 Webster Street
 Oakland, California



Vicinity Map



Douglas Parking
 1721 Webster Street
 Oakland, California



**Proposed Boring & Subslab
 Probe Location Map**

FIGURE
2

Pangea

Table 1. Soil Analytical Data: Petroleum Hydrocarbons - 1721 Webster Street, Oakland, California

| Sample ID | Date Sampled | Sample Depth (ft) | TPHg | Benzene | Toluene | Ethylbenzene | Xylenes | MTBE |
|--|--------------|-------------------|---------------------|------------|------------|--------------|-----------|------------|
| | | | ←————— mg/kg —————→ | | | | | |
| Residential ESL for shallow soil dw(<3 m bgs): | | | 100 | 0.044 | 2.9 | 2.9 | 2.3 | 0.023 |
| Residential ESL for deep soil dw(>3 m bgs): | | | 420 | 0.044 | 2.9 | 3.3 | 2.3 | 0.023 |
| Residential ESL for shallow soil non-dw(<3 m bgs): | | | 100 | 1 | 9.3 | 2.9 | 11 | 8.4 |
| Residential ESL for deep soil non-dw(>3 m bgs): | | | 420 | 1.20 | 9.3 | 4.7 | 11 | 8.4 |
| Commercial ESL for shallow soil non-dw (<3 m bgs): | | | 420 | 1.2 | 9.3 | 4.7 | 11 | 8.4 |
| Commercial ESL for deep soil non-dw (>3 m bgs): | | | 420 | 1.2 | 9.3 | 4.7 | 11 | 8.4 |

Cambria Environmental Technology, Inc. - 2003

| | | | | | | | | |
|------|-----------|------|-----|-------|------|-------|------|------|
| MW-6 | 6/27/2003 | 20.0 | 220 | <0.10 | 0.14 | <0.10 | 0.35 | <1.0 |
|------|-----------|------|-----|-------|------|-------|------|------|

Cambria Environmental Technology, Inc. - 1996

| | | | | | | | | |
|--------|-----------|------|------------|--------|--------|--------|--------|----|
| SB-A | 2/22/1996 | 19.5 | <1.0 | <0.005 | 0.007 | <0.005 | <0.005 | -- |
| SB-B | 2/22/1996 | 20.5 | 580 | <0.3 | 1.3 | 1.8 | 4.2 | -- |
| SB-C | 2/22/1996 | 19.5 | 1.4 | <0.005 | 0.013 | 0.027 | 0.12 | -- |
| SB-D | 2/22/1996 | 20.5 | 660 | <0.2 | 2.3 | <0.2 | 5.2 | -- |
| SB-E | 2/23/1996 | 20.5 | <1.0 | <0.005 | 0.009 | <0.005 | <0.005 | -- |
| SB-F | 2/23/1996 | 20.0 | <1.0 | <0.005 | 0.006 | <0.005 | <0.005 | -- |
| SB-G | 2/23/1996 | 20.0 | <1.0 | <0.005 | 0.009 | <0.005 | <0.005 | -- |
| SB-H | 5/3/1996 | 20.5 | 1.2 | <0.005 | 0.006 | 0.025 | 0.038 | -- |
| (MW-4) | 5/3/1996 | 31.0 | <1.0 | <0.005 | <0.005 | <0.005 | <0.005 | -- |
| SB-I | 5/3/1996 | 15.5 | <1.0 | <0.005 | <0.005 | <0.005 | <0.005 | -- |
| (MW-5) | 5/3/1996 | 26.0 | <1.0 | <0.005 | <0.005 | <0.005 | <0.005 | -- |

Gen-Tech Environmental - 1994

| | | | | | | | | |
|---------|----------|------|------------|--------|-----------|--------|-----------|----|
| EB-1@20 | 7/8/1994 | 20.0 | <1.0 | <0.005 | <0.005 | <0.005 | <0.005 | -- |
| EB-2@20 | 7/8/1994 | 20.0 | 300 | 0.2 | 1.7 | 0.26 | 3.0 | -- |
| EB-3@20 | 7/8/1994 | 20.0 | 51 | 0.039 | 0.56 | 0.32 | 2.9 | -- |
| EB-4@20 | 7/8/1994 | 20.0 | <1.0 | <0.005 | <0.005 | <0.005 | <0.005 | -- |
| EB-5@20 | 7/8/1994 | 20.0 | 650 | 0.17 | 5.2 | 4.4 | 48 | -- |
| EB-6@20 | 7/8/1994 | 20.0 | 68 | <0.005 | 22 | 4.3 | 23 | -- |

Parker Environmental - 1992

Beneath UST Samples

| | | | | | | | | |
|-----|----------|------|--------------|-------------|------------|------------|------------|----|
| T-1 | 8/3/1992 | 9.0 | 150 | 2.2 | 2.9 | 1.8 | 13 | -- |
| T-2 | 8/3/1992 | 9.0 | 120 | 0.62 | 0.56 | 0.87 | 2.2 | -- |
| T-3 | 8/6/1992 | 8.0 | 580 | 1.7 | 5.9 | 5.6 | 43 | -- |
| T-4 | 8/6/1992 | 8.0 | 1,500 | 11 | 140 | 48 | 280 | -- |
| T-5 | 8/6/1992 | 8.0 | 410 | 6.7 | 22 | 6.2 | 35 | -- |
| T-6 | 8/6/1992 | 12.0 | 1,400 | 12 | 71 | 29 | 150 | -- |
| T-7 | 8/6/1992 | 14.0 | 2.3 | 0.11 | 0.19 | 0.05 | 0.31 | -- |

Pangea

Table 1. Soil Analytical Data: Petroleum Hydrocarbons - 1721 Webster Street, Oakland, California

| Sample ID | Date Sampled | Sample Depth (ft) | TPHg | Benzene | Toluene | Ethylbenzene | Xylenes | MTBE |
|--|--------------|-------------------|------------|------------|------------|--------------|-----------|------------|
| | | | ← mg/kg → | | | | | |
| Residential ESL for shallow soil dw(<3 m bgs): | | | 100 | 0.044 | 2.9 | 2.9 | 2.3 | 0.023 |
| Residential ESL for deep soil dw(>3 m bgs): | | | 420 | 0.044 | 2.9 | 3.3 | 2.3 | 0.023 |
| Residential ESL for shallow soil non-dw(<3 m bgs): | | | 100 | 1 | 9.3 | 2.9 | 11 | 8.4 |
| Residential ESL for deep soil non-dw(>3 m bgs): | | | 420 | 1.20 | 9.3 | 4.7 | 11 | 8.4 |
| Commercial ESL for shallow soil non-dw (<3 m bgs): | | | 420 | 1.2 | 9.3 | 4.7 | 11 | 8.4 |
| Commercial ESL for deep soil non-dw (>3 m bgs): | | | 420 | 1.2 | 9.3 | 4.7 | 11 | 8.4 |

South Excavation Sidewall Samples

| | | | | | | | | |
|-----|----------|-----|--------------|------------|-----------|-----------|------------|----|
| SW1 | 8/6/1992 | 9.5 | 280 | 2.9 | 5.8 | 3.2 | 15 | -- |
| SW2 | 8/6/1992 | 7.0 | 1,500 | 5.7 | 40 | 18 | 150 | -- |
| SW3 | 8/6/1992 | 8.0 | 400 | 2.7 | 5.8 | 4.0 | 21 | -- |
| SW4 | 8/6/1992 | 9.0 | 2.3 | 0.42 | 0.028 | 0.077 | 0.18 | -- |

Piping and Dispenser Samples

| | | | | | | | | |
|-----|----------|-----|------|--------|--------|--------|--------|----|
| L-1 | 8/3/1992 | 1.5 | 2.6 | <0.005 | 0.01 | <0.005 | 0.03 | -- |
| L-2 | 8/3/1992 | 1.5 | <1.0 | <0.005 | <0.005 | <0.005 | <0.005 | -- |
| L-3 | 8/3/1992 | 1.5 | <1.0 | <0.005 | <0.005 | <0.005 | <0.005 | -- |
| L-4 | 8/3/1992 | 1.5 | <1.0 | <0.005 | <0.005 | <0.005 | <0.005 | -- |
| L-5 | 8/3/1992 | 2.0 | 8.2 | 0.01 | 0.02 | 0.012 | 0.092 | -- |
| L-6 | 8/3/1992 | 2.0 | <1.0 | <0.005 | 0.007 | <0.005 | 0.034 | -- |

Stockpile Samples

| | | | | | | | | |
|----|----------|-----|------------|------|-----|-----|-----------|----|
| C1 | 8/6/1992 | 1.5 | 560 | <0.1 | 5.0 | 3.1 | 24 | -- |
|----|----------|-----|------------|------|-----|-----|-----------|----|

Notes, Abbreviations and Methods:

mg/kg = Milligrams per kilogram, approximately equivalent to parts per million (ppm).

TPHd = Total petroleum hydrocarbons as diesel by modified EPA Method 8015.

TPHg = Total petroleum hydrocarbons by EPA Method 8015.

BTEX = Benzen, toluene, ethylbenzene, xylenes by EPA Method 8020/8021.

MTBE = Methyl tertiary-butyl ether by EPA Method 8020.

ESL = Environmental Screening Level for Shallow/Deep Soil with Residential and Commercial/Industrial Land Use, Groundwater is/is not a current or potential source of drinking water. (Table A/Table B/Table C/Table D).

ESL established by the SFBRWQCB, Interim Final - February 2005 and amended in February 2013.

Bold = Concentration equals or exceeds the Commercial ESL where groundwater is not a current of potential drinking water resource.

-- = Not available or not analyzed.

< n = Chemical not present at a concentration in excess of detection limit shown.

non-dw = groundwater is not a current or potential source of drinking water

dw = groundwater is a current or potential source of drinking water

PANGEA

Table 2 - Groundwater Elevation and Analytical Data.
Douglas Parking Company, 1721 Webster Street, Oakland, California

| Boring / Well ID <i>TOC</i> | Date | Depth to Water (ft) | Groundwater Elevation (ft amsl) | TPHg | Benzene | Toluene | Ethylbenzene (µg/L) | Xylenes | MTBE |
|--------------------------------|------------------|---------------------|---------------------------------|-------------------|----------------|----------------|---------------------|----------------|----------------|
| Monitoring Wells | | | | | | | | | |
| MW-1 | 12/2/1994 | 19.42 | 9.83 | ND | ND | ND | ND | ND | - |
| 29.25 | 3/6/1995 | 20.69 | 9.04 | ND | ND | ND | ND | ND | - |
| 29.73 | 7/11/1995 | 20.65 | 9.16 | ND | ND | ND | ND | ND | - |
| 29.81 | 5/10/1996 | 20.80 | 9.01 | ND | ND | ND | ND | ND | - |
| | 10/2/1996 | 21.35 | 8.46 | - | - | - | - | - | - |
| | 2/28/1997 | 20.57 | 9.24 | - | - | - | - | - | - |
| | 9/16/1997 | 21.50 | 8.31 | - | - | - | - | - | - |
| | 2/5/1998 | 20.91 | 8.90 | - | - | - | - | - | - |
| | 8/11/1998 | 20.50 | 9.31 | - | - | - | - | - | - |
| | 2/8/1999 | 21.42 | 8.39 | - | - | - | - | - | - |
| | 2/24/1999 | 22.99 | 6.82 | - | - | - | - | - | - |
| | 3/3/1999 | 20.84 | 8.97 | - | - | - | - | - | - |
| | 3/10/1999 | 20.89 | 8.92 | - | - | - | - | - | - |
| | 3/17/1999 | 20.84 | 8.97 | - | - | - | - | - | - |
| | 5/4/1999 | 20.80 | 9.01 | - | - | - | - | - | - |
| | 7/20/1999 | 21.25 | 8.56 | - | - | - | - | - | - |
| | 10/5/1999 | 21.37 | 8.44 | - | - | - | - | - | - |
| | 1/7/2000 | 21.65 | 8.16 | - | - | - | - | - | - |
| | 4/6/2000 | 21.05 | 8.76 | <50 | <0.5 | <0.5 | <0.5 | <0.5 | <5.0 |
| | 7/31/2000 | 21.13 | 8.68 | - | - | - | - | - | - |
| | 10/3/2000 | 21.69 | 8.12 | - | - | - | - | - | - |
| | 1/12/2001 | 22.00 | 7.81 | - | - | - | - | - | - |
| | 4/11/2001 | 22.16 | 7.65 | - | - | - | - | - | - |
| | 7/6/2001 | 22.57 | 7.24 | - | - | - | - | - | - |
| | 10/25/2001 | 22.71 | 7.10 | - | - | - | - | - | - |
| | 3/4/2002 | 22.53 | 7.28 | - | - | - | - | - | - |
| | 4/18/2002 | 22.81 | 7.00 | - | - | - | - | - | - |
| | 7/9/2002 | 22.95 | 6.86 | - | - | - | - | - | - |
| | 10/4/2002 | 23.13 | 6.68 | - | - | - | - | - | - |
| | 1/12/2003 | 22.05 | 7.76 | - | - | - | - | - | - |
| | 4/21/2003 | 21.17 | 8.64 | - | - | - | - | - | - |
| 32.75 | 7/21/2003 | 21.39 | 11.36 | - | - | - | - | - | - |
| | 10/2/2003 | 21.64 | 11.11 | - | - | - | - | - | - |
| | 1/15/2004 | 21.10 | 11.65 | - | - | - | - | - | - |
| | 4/5/2004 | 21.20 | 11.55 | - | - | - | - | - | - |
| | 8/9/2004 | 22.97 | 9.78 | - | - | - | - | - | - |
| | 10/7/2004 | 23.55 | 9.20 | - | - | - | - | - | - |
| | 2/7/2005 | 20.90 | 11.85 | <50 | <0.5 | <0.5 | <0.5 | <0.5 | <5.0 |
| | 4/5/2005 | 20.60 | 12.15 | - | - | - | - | - | - |
| | 7/6/2005 | 20.66 | 12.09 | - | - | - | - | - | - |
| | 10/10/2005 | 21.16 | 11.59 | - | - | - | - | - | - |
| | 1/26/2006 | 20.73 | 12.02 | <50 | <0.5 | <0.5 | <0.5 | <0.5 | <5.0 |
| | 4/10/2006 | 20.05 | 12.70 | - | - | - | - | - | - |
| | 7/6/2006 | 20.90 | 11.85 | <50 | <0.5 | <0.5 | <0.5 | <0.5 | <5.0 |
| | 10/26/2006 | 21.80 | 10.95 | <50 | <0.5 | <0.5 | <0.5 | <0.5 | <5.0 |
| | 1/19/2007 | 22.02 | 10.73 | -- | -- | -- | -- | -- | -- |
| | 4/17/2007 | 22.13 | 10.62 | -- | -- | -- | -- | -- | -- |
| | 7/6/2007 | 21.83 | 10.92 | -- | -- | -- | -- | -- | -- |
| | 10/15/2007 | 22.28 | 10.47 | -- | -- | -- | -- | -- | -- |
| | 1/17/2008 | 22.33 | 10.42 | <50 | <0.5 | <0.5 | <0.5 | <0.5 | <5.0 |
| | 4/9/2008 | 22.11 | 10.64 | -- | -- | -- | -- | -- | -- |
| | 7/17/2008 | 22.50 | 10.25 | -- | -- | -- | -- | -- | -- |
| | 10/27/2008 | 22.75 | 10.00 | -- | -- | -- | -- | -- | -- |
| | 1/9/2009 | 22.89 | 9.86 | <50 | <0.5 | <0.5 | <0.5 | <0.5 | <5.0 |
| | 4/27/2009 | 22.40 | 10.35 | -- | -- | -- | -- | -- | -- |
| | 7/9/2009 | 22.55 | 10.20 | -- | -- | -- | -- | -- | -- |
| | 2/3/2010 | 22.08 | 10.67 | <50 | <0.5 | <0.5 | <0.5 | <0.5 | <5.0 |
| | 7/13/2010 | 21.20 | 11.55 | --- | --- | --- | --- | --- | --- |
| | 1/17/2011 | | | Well Inaccessible | | | | | |
| | 7/12/2011 | 20.72 | 12.03 | -- | -- | -- | -- | -- | -- |
| | 1/11/2012 | 21.33 | 11.42 | <50 | <0.5 | <0.5 | <0.5 | <0.5 | <5.0 |
| | 7/25/2012 | 20.94 | 11.81 | -- | -- | -- | -- | -- | -- |
| | 1/25/2013 | 21.41 | 11.34 | <50 | <0.5 | <0.5 | <0.5 | <0.5 | <5.0 |

PANGEA

Table 2 - Groundwater Elevation and Analytical Data.
Douglas Parking Company, 1721 Webster Street, Oakland, California

| Boring / Well ID TOC | Date | Depth to Water (ft) | Groundwater Elevation (ft amsl) | ← (µg/L) → | | | | | |
|----------------------------|------------------|---------------------------|---------------------------------------|--------------|-----------|-----------|--------------|------------|---------------|
| | | | | TPHg | Benzene | Toluene | Ethylbenzene | Xylenes | MTBE |
| MW-2 | 12/2/1994 | 19.50 | 7.60 | 61,300 | 3,000 | 3,900 | 160 | 4,500 | - |
| 27.10 | 3/6/1995 | 18.49 | 8.61 | 98,000 | 8,400 | 16,000 | 2,000 | 2,600 | - |
| 27.40 | 7/11/1995 | 18.45 | 8.95 | 38,000 | 3,100 | 7,500 | 940 | 3,700 | - |
| | 5/10/1996 | 18.56 | 8.84 | 63,000 | 7,400 | 16,000 | 1,500 | 6,000 | - |
| | 10/2/1996 | 19.15 | 8.25 | 21,000 | 2,200 | 3,400 | 430 | 1,600 | - |
| | 2/28/1997 | 18.43 | 8.97 | 39,000 | 4,700 | 9,600 | 950 | 4,200 | ND |
| | 9/16/1997 | 19.26 | 8.14 | 29,000 | 3,300 | 5,800 | 690 | 2,900 | <620 |
| | 2/5/1998 | 18.66 | 8.74 | 10,000 | 1,000 | 2,000 | 170 | 860 | <330 |
| | 8/11/1998 | 18.41 | 8.99 | 12,000 | 1,200 | 2,300 | 260 | 1,400 | 300 |
| | 2/8/1999 | 19.84 | 7.56 | 5,500 | 740 | 1,200 | 150 | 780 | 60 |
| | 2/17/1999 | 18.94 | 8.46 | - | - | - | - | - | - |
| | 2/24/1999 | 20.76 | 6.64 | - | - | - | - | - | - |
| | 3/3/1999 | 18.55 | 8.85 | - | - | - | - | - | - |
| | 3/10/1999 | 20.74 | 6.66 | - | - | - | - | - | - |
| | 3/17/1999 | 18.57 | 8.83 | - | - | - | - | - | - |
| | 5/4/1999 | 18.55 | 8.85 | 90,000 | 9,200 | 21,000 | 1,600 | 10,000 | 560 |
| | 7/20/1999 | 18.98 | 8.42 | 28,000 | 2,100 | 3,700 | 900 | 4,200 | <860 |
| | 10/5/1999 | 19.10 | 8.30 | 11,000 | 870 | 180 | 30 | 1,400 | <110 |
| | 1/7/2000 | 19.41 | 7.99 | 15,000 | 1,300 | 2,100 | 440 | 1,800 | <14 |
| | 4/6/2000 | 18.80 | 8.60 | 17,000 | 1,800 | 3,100 | 500 | 2,200 | <50 |
| | 7/31/2000 | 18.87 | 8.53 | 17,000 | 1,500 | 2,700 | 430 | 2,100 | <200 |
| | 10/3/2000 | 19.45 | 7.95 | 27,000 | 2,500 | 4,000 | 660 | 2,900 | <50 |
| | 1/12/2001 | 19.80 | 7.60 | 25,000 | 2,700 | 4,100 | 670 | 3,000 | <200 |
| | 4/11/2001 | 20.03 | 7.37 | 97,000 | 9,500 | 21,000 | 2,200 | 7,900 | <200 |
| | 7/6/2001 | 20.19 | 7.21 | 3,500 | 500 | 150 | 11 | 420 | <5.0 |
| | 10/25/2001 | 20.35 | 7.05 | 3,800 | 620 | 230 | 70 | 400 | <50 |
| | 3/4/2002 | 20.37 | 7.03 | 46,000 | 7,300 | 12,000 | 870 | 3,200 | <500 |
| | 4/18/2002 | 20.15 | 7.25 | 68,000 | 5,100 | 8,900 | 1,100 | 4,000 | <1,000 |
| | 7/9/2002 | 21.09 | 6.31 | 1,000 | 200 | 8.9 | 0.67 | 82 | <10 |
| | 10/4/2002 | 21.28 | 6.12 | 270 | 100 | 3.4 | 0.53 | 10 | <5.0 |
| | 1/12/2003 | 20.59 | 6.81 | 67,000 | 7,600 | 13,000 | 1,400 | 5,600 | <500 |
| | 4/21/2003 | 19.98 | 7.42 | 78,000 | 7,700 | 12,000 | 1,900 | 6,900 | <500 |
| 30.40 | 7/21/2003 | 20.08 | 10.32 | 1,800 | 360 | 16 | <5.0 | 190 | <50 |
| | 10/2/2003 | 20.41 | 9.99 | 4,000 | 790 | 110 | 60 | 350 | <50 |
| | 1/15/2004 | 19.93 | 10.47 | 8,100 | 6.1 | 23 | 44 | 530 | <50 |
| | 4/5/2004 | 18.99 | 11.41 | 14,000 | 1,600 | 2,100 | 550 | 2,500 | <500 |
| | 8/9/2004 | 19.79 | 10.61 | 1,200 | 210 | 16 | 14 | 100 | <20 |
| | 10/7/2004 | 20.26 | 10.14 | 1,100 | 2.3 | 9.8 | 2.9 | 36 | <5.0 |
| | 2/7/2005 | 18.80 | 11.60 | 45,000 | 4,400 | 4,800 | 1,400 | 5,800 | <200 |
| | 4/5/2005 | 18.40 | 12.00 | 34,000 | 3,700 | 3,600 | 1,200 | 5,300 | <500 (<5.0) |
| | 7/6/2005 | 18.48 | 11.92 | 24,000 | 1,600 | 1,700 | 570 | 2,800 | <500 |
| | 10/10/2005 | 19.00 | 11.40 | 25,000 | 1,700 | 2,100 | 710 | 3,200 | <500 |
| | 1/26/2006 | 18.58 | 11.82 | 60,000 | 4,600 | 7,200 | 1,600 | 6,900 | <1,000 |
| | 4/10/2006 | 17.84 | 12.56 | 56,000 | 4,900 | 7,500 | 1,200 | 7,400 | <500 |
| | 7/6/2006 | 18.76 | 11.64 | 28,000 | 1,900 | 1,700 | 720 | 2,900 | <500 |
| | 10/26/2006 | 19.60 | 10.80 | 43,000 | 2,800 | 2,500 | 1,700 | 7,600 | <500 |
| | 1/19/2007 | 19.84 | 10.56 | 31,000 | 2,700 | 2,400 | 1,400 | 5,800 | <150 |
| | 4/17/2007 | 19.90 | 10.50 | 37,000 | 3,200 | 2,900 | 1,600 | 6,400 | <400 |
| | 7/6/2007 | 19.63 | 10.77 | 30,000 | 3,200 | 2,000 | 1,500 | 5,200 | <250 |
| | 10/15/2007 | 20.11 | 10.29 | 20,000 | 1,200 | 990 | 650 | 2,300 | <500 |
| | 1/17/2008 | 20.10 | 10.30 | 38,000 | 2,900 | 5,100 | 1,200 | 5,000 | <210 |
| | 4/9/2008 | 20.12 | 10.28 | 51,000 | 3,000 | 6,400 | 1,700 | 6,500 | <250 |
| | 7/17/2008 | 20.01 | 10.39 | 22,000 | 180 | 500 | 660 | 2,100 | <250 |
| | 10/27/2008 | 20.61 | 9.79 | 26,000 | 570 | 2,100 | 670 | 3,400 | <50 |
| | 1/9/2009 | 20.80 | 9.60 | 16,000 | 240 | 680 | 460 | 3,000 | <100 |
| | 4/27/2009 | 20.17 | 10.23 | 16,000 | 130 | 660 | 570 | 3,600 | <500 |
| | 7/9/2009 | 20.36 | 10.04 | 8,500 | 30 | 110 | 250 | 1,400 | <100 |
| | 2/3/2010 | 19.84 | 10.56 | 22,000 | 47 | 140 | 500 | 3,000 | <100 |
| | 7/13/2010 | 19.08 | 11.32 | 1,900 | 3.5 | 5.8 | 38 | 110 | <5.0 |
| | 1/17/2011 | 19.02 | 11.38 | 17,000 | 23 | 100 | 330 | 2,200 | <100 |
| | 7/12/2011 | 18.52 | 11.88 | 15,000 | 22 | 30 | 190 | 740 | <50 |
| | 1/12/2011 | 19.18 | 11.22 | 20,000 | 17 | 47 | 250 | 2,100 | <84 |
| | 7/25/2012 | 18.83 | 11.57 | 440 | <0.5 | 2.2 | 1.0 | 39 | <5.0 |
| | 1/25/2013 | 19.21 | 11.19 | 8,300 | 17 | 11 | 140 | 510 | <50 |

PANGEA

Table 2 - Groundwater Elevation and Analytical Data.
Douglas Parking Company, 1721 Webster Street, Oakland, California

| Boring / Well ID TOC | Date | Depth to Water (ft) | Groundwater Elevation (ft amsl) | TPHg | Benzene | Toluene | Ethylbenzene (µg/L) | Xylenes | MTBE |
|----------------------------|------------------|---------------------------|---------------------------------------|--------------|----------------|------------|------------------------|------------|---------------|
| | | | | | | | | | |
| MW-3 | 12/2/1994 | 22.15 | 7.35 | 394,000 | 1,200 | ND | 1,800 | 4,000 | - |
| 29.50 | 3/6/1995 | 20.09 | 9.16 | 21,000 | 400 | 150 | 24 | 62 | - |
| 29.25 | 7/11/1995 | 19.99 | 9.57 | 12,000 | ND | 10 | 16 | 99 | - |
| 29.56 | 5/10/1996 | 20.24 | 9.32 | 8,600 | ND | 7.6 | 16 | 84 | - |
| | 10/2/1996 | 20.90 | 8.66 | 11,000 | ND | 7.4 | 19 | 92 | - |
| | 2/28/1997 | 20.12 | 9.44 | 6,000 | ND | 4.4 | 17 | 88 | 50 |
| | 9/16/1997 | 20.97 | 8.59 | 6,500 | <0.5 | 0.69 | 1.2 | 6.7 | <5.0 |
| | 2/5/1998 | 20.39 | 9.17 | 5,400 | <0.5 | 6.3 | 15 | 86 | <63 |
| | 8/11/1998 | 19.95 | 9.61 | 2,700 | <0.5 | 3.5 | 3.2 | 12 | <10 |
| | 2/8/1999 | 20.58 | 8.98 | 6,100 | <0.5 | 8.1 | 18 | 80 | <140 |
| | 2/17/1999 | 20.53 | 9.03 | - | - | - | - | - | - |
| | 2/24/1999 | 22.53 | 7.03 | - | - | - | - | - | - |
| | 3/3/1999 | 20.28 | 9.28 | - | - | - | - | - | - |
| | 3/10/1999 | 22.45 | 7.11 | - | - | - | - | - | - |
| | 3/17/1999 | 20.26 | 9.30 | - | - | - | - | - | - |
| | 5/4/1999 | 20.24 | 9.32 | 11,000 | <2 | <2 | 9.8 | 140 | <10 |
| | 7/20/1999 | 20.68 | 8.88 | 11,000 | <0.5 | 3.1 | 13 | 88 | <80 |
| | 10/5/1999 | 20.81 | 8.75 | 31,000 | 62 | <0.5 | 21 | 170 | <90 |
| | 1/7/2000 | 21.09 | 8.47 | 13,000 | <0.5 | <2 | 21 | 140 | <80 |
| | 4/6/2000 | 20.48 | 9.08 | 5,300 | 1.5 | 1.4 | 9.8 | 60 | <30 |
| | 7/31/2000 | 20.62 | 8.94 | 7,100 | 3.5 | 1.0 | 12 | 66 | <5.0 |
| | 10/3/2000 | 21.13 | 8.43 | 8,000 | <0.5 | 3.3 | 11 | 70 | <40 |
| | 1/12/2001 | 21.45 | 8.11 | 11,000 | 4.3 | 6.7 | 11 | 73 | <70 |
| | 4/11/2001 | 21.69 | 7.87 | 10,000 | <0.5 | <0.5 | 11 | 65 | <10 |
| | 7/6/2001 | 21.60 | 7.96 | 13,000 | 5.3 | 1.6 | 11 | 58 | <5.0 |
| | 10/25/2001 | 21.70 | 7.86 | 11,000 | <0.5 | 3.0 | 15 | 70 | <10 |
| | 3/4/2002 | 21.65 | 7.91 | 1,900 | 1.3 | 0.8 | <0.5 | 15 | <5.0 |
| | 4/18/2002 | 21.77 | 7.79 | 1,500 | 1.0 | 0.97 | 1.3 | 5.8 | <5 |
| | 7/9/2002 | 22.03 | 7.53 | 13,000 | 6.8 | 5.7 | 13 | 59 | <90 |
| | 10/4/2002 | 22.15 | 7.41 | 8,400 | <10 | <10 | <10 | 42 | <100 |
| | 1/12/2003 | 21.13 | 8.43 | 9,000 | 9.5 | 5.1 | 8.5 | 46 | <90 |
| | 4/21/2003 | 20.63 | 8.93 | 10,000 | <5.0 | <5.0 | 8.5 | 32 | <50 |
| 32.56 | 7/21/2003 | 20.68 | 11.88 | 9,600 | <2.5 | <2.5 | 7.4 | 39 | 48 (<1.0) |
| | 10/2/2003 | 20.99 | 11.57 | 12,000 | <5.0 | <5.0 | 10 | 40 | <90 |
| | 1/15/2004 | 20.74 | 11.82 | 13,000 | 37 | 41 | 78 | 930 | <50 |
| | 4/5/2004 | 20.59 | 11.97 | 4,500 | <1.7 | <1.7 | <1.7 | 12 | <17 |
| | 8/9/2004 | 22.18 | 10.38 | 2,100 | <1.0 | 3.7 | <1.0 | 8.1 | <10 |
| | 10/7/2004 | 22.79 | 9.77 | 2,400 | 6.5 | 26 | 7.5 | 89 | <15 |
| | 2/7/2005 | 20.35 | 12.21 | 6,800 | 2.2 | 5.6 | 2.0 | 12 | <30 |
| | 4/5/2005 | 19.95 | 12.61 | 6,100 | 2.3 | 2.6 | 1.3 | 8.3 | <45 (<0.5) |
| | 7/6/2005 | 19.93 | 12.63 | 4,500 | <1.0 | 1.5 | 1.0 | 8.3 | <10 |
| | 10/10/2005 | 20.45 | 12.11 | 3,800 | 0.73 | <0.5 | 0.98 | 5.7 | <15 |
| | 1/26/2006 | 20.05 | 12.51 | 5,100 | <0.5 | 1.1 | <0.5 | 6.6 | <15 |
| | 4/10/2006 | 19.39 | 13.17 | 1,900 | 0.55 | 1.6 | 0.51 | 4.1 | <10 |
| | 7/6/2006 | 20.25 | 12.31 | 5,600 | <1.0 | 2.3 | <1.0 | 6.4 | <20 |
| | 10/26/2006 | 21.07 | 11.49 | 8,000 | 2.5 | 1.0 | 2.3 | 12 | <35 |
| | 1/19/2007 | 21.38 | 11.18 | 77,000 | 19 | 40 | 9.5 | 130 | <300 |
| | 4/17/2007 | 21.45 | 11.11 | 7,400 | 2.7 | 6.6 | 1.1 | 12 | <40 |
| | 7/6/2007 | 21.29 | 11.27 | 7,100 | 2.4 | 5.6 | 0.85 | 10 | <30 |
| | 10/15/2007 | 21.62 | 10.94 | 10,000 | <5.0 | <5.0 | <5.0 | 14 | <50 |
| | 1/17/2008 | 21.68 | 10.88 | 6,400 | 1.8 | <0.5 | 1.0 | 8.4 | 23 |
| | 4/9/2008 | 21.42 | 11.14 | 4,700 | 1.7 | 2.2 | <0.5 | 3.8 | <18 |
| | 7/17/2008 | 22.10 | 10.46 | 7,700 | 2.9 | 3.1 | 1.4 | 11 | <60 |
| | 10/27/2008 | 22.13 | 10.43 | 9,700 | <1.7 | 1.8 | 2.3 | 11 | <17 |
| | 1/9/2009 | 22.27 | 10.29 | 9,800 | 1.7 | 2.0 | 3.0 | 14 | <17 |
| | 4/27/2009 | 21.74 | 10.82 | 8,700 | 1.9 | 3.3 | <1.7 | 11 | <50 |
| | 7/9/2009 | 21.92 | 10.64 | 10,000 | <2.5 | 4.1 | 2.6 | 11 | <60 |
| | 2/3/2010 | 21.55 | 11.01 | 5,300 | 1.5 | 2.3 | <0.5 | 2.7 | <25 |
| | 7/13/2010 | 21.31 | 11.25 | 4,400 | <2.5 | 9.0 | <2.5 | 4.6 | <25 |
| | 1/17/2011 | 20.75 | 11.81 | 4,100 | 1.2 | 1.8 | <0.5 | 2.7 | <20 |
| | 7/12/2011 | 20.14 | 12.42 | 4,500 | 2.4 | 2.8 | <0.5 | 5.0 | <25 |
| | 1/11/2012 | 20.80 | 11.76 | 3,000 | 1.1 | 1.6 | <0.5 | 1.9 | <15 |
| | 7/25/2012 | 20.44 | 12.12 | 5,400 | <1.7 | <1.7 | <1.7 | 4.1 | <17 |
| | 1/25/2013 | 20.84 | 11.72 | 4,900 | <1.7 | 2.7 | <1.7 | 3.5 | <17 |

PANGEA

Table 2 - Groundwater Elevation and Analytical Data.
Douglas Parking Company, 1721 Webster Street, Oakland, California

| Boring / Well ID TOC | Date | Depth to Water (ft) | Groundwater Elevation (ft amsl) | TPHg | Benzene | Toluene | Ethylbenzene | Xylenes | MTBE |
|----------------------------|------------------|---------------------------|---------------------------------------|--------------|-----------|-----------|--------------|-----------|---------------|
| | | | | ← | | | (µg/L) | | → |
| MW-4 | 5/10/1996 | 16.98 | 8.31 | 14,000 | ND | 1,200 | 720 | 3,100 | - |
| 25.29 | 10/2/1996 | 17.65 | 7.64 | 12,000 | ND | 650 | 580 | 2,200 | - |
| | 2/28/1997 | 16.80 | 8.49 | 13,000 | ND | 1,100 | 750 | 2,700 | 110 |
| | 9/17/1997 | 17.93 | 7.36 | 13,000 | <2.5 | 820 | 750 | 2,900 | <190 |
| | 2/5/1998 | 16.78 | 8.51 | 13,000 | <1.0 | 690 | 690 | 2,900 | <170 |
| | 8/11/1998 | 16.59 | 8.70 | 15,000 | <5 | 360 | 520 | 1,900 | 280 |
| | 2/8/1999 | 17.10 | 8.19 | 9,800 | <5 | 680 | 770 | 2,200 | 300 |
| | 2/24/1999 | 18.95 | 6.34 | - | - | - | - | - | - |
| | 3/3/1999 | 16.80 | 8.49 | - | - | - | - | - | - |
| | 3/10/1999 | 16.86 | 8.43 | - | - | - | - | - | - |
| | 3/17/1999 | 16.82 | 8.47 | - | - | - | - | - | - |
| | 5/4/1999 | 16.86 | 8.43 | 11,000 | 46 | 600 | 620 | 1,900 | <100 |
| | 7/20/1999 | 17.30 | 7.99 | 13,000 | <0.5 | 470 | 7.0 | 2,000 | <150 |
| | 10/5/1999 | 17.43 | 7.86 | 18,000 | 4.4 | 720 | 800 | 2,100 | <120 |
| | 1/7/2000 | 17.78 | 7.51 | 18,000 | <2 | 930 | 990 | 2,700 | <30 |
| | 4/6/2000 | 17.17 | 8.12 | 8,000 | 31 | 390 | 530 | 1,300 | <10 |
| | 7/31/2000 | 17.21 | 8.08 | 6,200 | 13 | 170 | 460 | 850 | <10 |
| | 10/3/2000 | 18.00 | 7.29 | 14,000 | 42 | 820 | 730 | 2,000 | <50 |
| | 1/12/2001 | 18.20 | 7.09 | <50 | <0.5 | <0.5 | <0.5 | <0.5 | <5.0 |
| | 4/11/2001 | 18.31 | 6.98 | <50 | <0.5 | <0.5 | <0.5 | <0.5 | <5.0 |
| | 7/6/2001 | 18.35 | 6.94 | 470 | 2.3 | 1.6 | 0.81 | 43 | <5.0 |
| | 10/25/2001 | 18.47 | 6.82 | 110 | 0.70 | <0.5 | <0.5 | 3.3 | <5.0 |
| | 3/4/2002 | 18.43 | 6.86 | <50 | <0.5 | <0.5 | <0.5 | <0.5 | <5.0 |
| | 4/18/2002 | 18.61 | 6.68 | <50 | <0.5 | <0.5 | <0.5 | <0.5 | <5.0 |
| | 7/9/2002 | 19.50 | 5.79 | <50 | <0.5 | <0.5 | <0.5 | <0.5 | <5.0 |
| | 10/4/2002 | 19.83 | 5.46 | 310 | 2.0 | 2.9 | 13 | 16 | <0.5 |
| 1/12/2003 | 19.07 | 6.22 | <50 | <0.5 | <0.5 | <0.5 | <0.5 | <5.0 | |
| 4/21/2003 | 18.71 | 6.58 | <50 | <0.5 | <0.5 | <0.5 | <0.5 | <5.0 | |
| 28.29 | 7/21/2003 | 18.81 | 9.48 | <50 | <0.5 | <0.5 | <0.5 | <0.5 | <5.0 |
| | 10/2/2003 | 19.02 | 9.27 | 59 | 0.78 | <0.5 | 1.1 | 0.91 | <5.0 |
| | 1/15/2004 | 18.68 | 9.61 | <50 | <0.5 | <0.5 | <0.5 | <0.5 | <5.0 |
| | 4/5/2004 | 17.41 | 10.88 | 6,200 | 29 | 250 | 450 | 730 | <100 |
| | 8/9/2004 | 19.07 | 9.22 | <50 | <0.5 | <0.5 | <0.5 | <0.5 | <5.0 |
| | 10/7/2004 | 19.65 | 8.64 | <50 | <0.5 | <0.5 | <0.5 | <0.5 | <5.0 |
| | 2/7/2005 | 17.21 | 11.08 | 8,700 | 48 | 340 | 550 | 720 | <100 |
| | 4/5/2005 | 16.78 | 11.51 | 6,900 | 27 | 290 | 520 | 660 | <170 (<0.5) |
| | 7/6/2005 | 16.98 | 11.31 | 5,600 | <5.0 | 130 | 470 | 480 | <50 |
| | 10/10/2005 | 17.59 | 10.70 | 6,300 | 23 | 78 | 530 | 430 | <50 |
| | 1/26/2006 | 17.08 | 11.21 | 5,600 | 41 | 68 | 400 | 290 | <120 |
| | 4/10/2006 | 16.27 | 12.02 | 2,900 | 39 | 32 | 200 | 140 | <60 |
| | 7/6/2006 | 17.20 | 11.09 | 5,400 | 65 | 59 | 340 | 150 | <120 |
| | 10/26/2006 | 18.06 | 10.23 | 7,200 | 72 | 46 | 460 | 200 | <150 |
| | 1/19/2007 | 18.29 | 10.00 | 7,100 | 140 | 35 | 520 | 150 | <200 |
| | 4/17/2007 | 18.30 | 9.99 | 4,900 | 90 | 32 | 290 | 89 | <110 |
| | 7/6/2007 | 18.00 | 10.29 | 4,600 | 91 | 30 | 210 | 55 | <90 |
| | 10/15/2007 | 18.52 | 9.77 | 8,600 | 200 | 62 | 480 | 110 | <210 |
| | 1/17/2008 | 18.46 | 9.83 | 820 | 15 | 3.7 | 25 | 9.3 | <10 |
| | 4/9/2008 | 18.23 | 10.06 | 3,600 | 55 | 20 | 160 | 64 | <60 |
| | 7/17/2008 | 18.72 | 9.57 | 6,500 | 210 | 47 | 510 | 180 | <180 |
| | 10/27/2008 | 19.07 | 9.22 | 7,700 | 200 | 28 | 450 | 87 | <150 |
| | 1/9/2009 | 19.12 | 9.17 | 4,400 | 180 | 34 | 180 | 93 | <150 |
| | 4/27/2009 | 18.52 | 9.77 | 2,500 | 110 | 24 | 190 | 69 | <150 |
| | 7/9/2009 | 18.78 | 9.51 | 5,600 | 150 | 34 | 270 | 83 | <250 |
| 2/3/2010 | 18.24 | 10.05 | 2,900 | 38 | 20 | 69 | 54 | <50 | |
| 7/13/2010 | 17.59 | 10.70 | 1,100 | 20 | 7.6 | 43 | 26 | <60 | |
| 1/17/2011 | 17.42 | 10.87 | 2,900 | 16 | 43 | 60 | 99 | <15 | |
| 7/12/2011 | 17.01 | 11.28 | <50 | <0.5 | 0.56 | 0.52 | 0.93 | <5.0 | |
| 1/11/2012 | 17.68 | 10.61 | 4,100 | 52 | 52 | 49 | 130 | <90 | |
| 7/25/2012 | 17.26 | 11.03 | 100 | 1.2 | <0.5 | <0.5 | <0.5 | <5.0 | |
| | 1/25/2013 | 17.58 | 10.71 | 3,500 | 33 | 20 | 23 | 65 | <35 |

PANGEA

Table 2 - Groundwater Elevation and Analytical Data.
Douglas Parking Company, 1721 Webster Street, Oakland, California

| Boring / Well ID TOC | Date | Depth to Water (ft) | Groundwater Elevation (ft amsl) | Groundwater Analytical Data (µg/L) | | | | | |
|----------------------------|--------------|---------------------------|---------------------------------------|------------------------------------|----------------|----------------|----------------|----------------|------|
| | | | | TPHg | Benzene | Toluene | Ethylbenzene | Xylenes | MTBE |
| MW-5 21.97 | 5/10/1996 | 14.60 | 7.37 | ND | ND | ND | ND | ND | - |
| | 10/2/1996 | 15.25 | 6.72 | ND | ND | ND | ND | ND | - |
| | 2/28/1997 | 14.31 | 7.66 | ND | ND | ND | ND | ND | ND |
| | 9/17/1997 | 15.18 | 6.79 | <0.5 | <0.5 | <0.5 | <0.5 | <0.5 | <5.0 |
| | 2/5/1998 | 13.64 | 8.33 | <50 | <0.5 | <0.5 | <0.5 | <0.5 | <5.0 |
| | 8/11/1998 | 13.92 | 8.05 | <50 | <0.5 | <0.5 | <0.5 | <0.5 | <5.0 |
| | 2/8/1999 | 14.19 | 7.78 | <50 | <0.5 | <0.5 | <0.5 | <0.5 | <5.0 |
| | 2/24/1999 | 16.18 | 5.79 | - | - | - | - | - | - |
| | 3/3/1999 | 14.23 | 7.74 | - | - | - | - | - | - |
| | 3/10/1999 | 14.32 | 7.65 | - | - | - | - | - | - |
| | 3/17/1999 | 14.25 | 7.72 | - | - | - | - | - | - |
| | 5/4/1999 | 14.41 | 7.56 | <50 | <0.5 | <0.5 | <0.5 | <0.5 | <5.0 |
| | 7/20/1999 | 14.44 | 7.53 | <50 | <0.5 | <0.5 | <0.5 | <0.5 | <5.0 |
| | 10/5/1999 | 14.79 | 7.18 | <50 | <0.5 | <0.5 | <0.5 | <0.5 | <5.0 |
| | 1/7/2000* | 15.23 | 6.74 | - | - | - | - | - | - |
| | 4/6/2000 | 14.74 | 7.23 | <50 | <0.5 | <0.5 | <0.5 | <0.5 | <5.0 |
| | 7/31/2000 | 14.52 | 7.45 | <50 | <0.5 | <0.5 | <0.5 | <0.5 | <5.0 |
| | 10/3/2000 | 15.37 | 6.60 | <50 | <0.5 | <0.5 | <0.5 | <0.5 | <5.0 |
| | 1/12/2001 | 15.70 | 6.27 | 6,400 | 13 | 290 | 450 | 1,100 | <40 |
| | 4/11/2001 | 15.78 | 6.19 | <50 | <0.5 | <0.5 | <0.5 | <0.5 | <5.0 |
| | 7/6/2001 | 15.97 | 6.00 | <50 | <0.5 | <0.5 | <0.5 | <0.5 | <5.0 |
| 10/25/2001 | 16.05 | 5.92 | <50 | <0.5 | <0.5 | <0.5 | <0.5 | <5.0 | |
| 3/4/2002 | 16.21 | 5.76 | <50 | <0.5 | <0.5 | <0.5 | <0.5 | <5.0 | |
| 4/18/2002 | 16.59 | 5.38 | <50 | <0.5 | <0.5 | <0.5 | <0.5 | <5.0 | |
| 7/9/2002 | 16.94 | 5.03 | 170 | 1.0 | 0.65 | 2.1 | 4.0 | <15 | |
| 10/4/2002 | 17.14 | 4.83 | <50 | <0.5 | <0.5 | <0.5 | <0.5 | <5.0 | |
| 1/12/2003 | 16.58 | 5.39 | <50 | <0.5 | <0.5 | <0.5 | <0.5 | <5.0 | |
| 4/21/2003 | 15.90 | 6.07 | <50 | <0.5 | <0.5 | <0.5 | <0.5 | <5.0 | |
| 7/21/2003 | 16.03 | 8.96 | <50 | <0.5 | <0.5 | <0.5 | <0.5 | <5.0 | |
| 10/2/2003 | 16.33 | 8.66 | <50 | <0.5 | <0.5 | <0.5 | <0.5 | <5.0 | |
| 1/15/2004 | 16.21 | 8.78 | <50 | <0.5 | <0.5 | <0.5 | <0.5 | <5.0 | |
| 4/5/2004 | 15.01 | 9.98 | <50 | <0.5 | <0.5 | <0.5 | <0.5 | <5.0 | |
| 8/9/2004 | 16.85 | 8.14 | <50 | <0.5 | <0.5 | <0.5 | <0.5 | <5.0 | |
| 10/7/2004 | 17.48 | 7.51 | <50 | <0.5 | <0.5 | <0.5 | <0.5 | <5.0 | |
| 2/7/2005 | 16.52 | 8.47 | <50 | <0.5 | <0.5 | <0.5 | <0.5 | <5.0 | |
| 4/5/2005 | 14.45 | 10.54 | <50 | <0.5 | <0.5 | <0.5 | <0.5 | <5.0 (<0.5) | |
| 7/6/2005 | 14.85 | 10.14 | <50 | <0.5 | <0.5 | <0.5 | <0.5 | <5.0 | |
| 10/10/2005 | 15.44 | 9.55 | <50 | <0.5 | <0.5 | <0.5 | <0.5 | <5.0 | |
| 1/26/2006 | 14.96 | 10.03 | <50 | <0.5 | <0.5 | <0.5 | <0.5 | <5.0 | |
| 4/10/2006 | 14.01 | 10.98 | <50 | <0.5 | <0.5 | <0.5 | <0.5 | <5.0 | |
| 7/6/2006 | 15.17 | 9.82 | <50 | <0.5 | <0.5 | <0.5 | <0.5 | <5.0 | |
| 10/26/2006 | 15.94 | 9.05 | <50 | <0.5 | <0.5 | <0.5 | <0.5 | <5.0 | |
| 1/19/2007 | 16.05 | 8.94 | <50 | <0.5 | <0.5 | <0.5 | <0.5 | <5.0 | |
| 4/17/2007 | 15.99 | 9.00 | <50 | <0.5 | <0.5 | <0.5 | <0.5 | <5.0 | |
| 7/6/2007 | 15.50 | 9.49 | <50 | <0.5 | <0.5 | <0.5 | <0.5 | <5.0 | |
| 10/15/2007 | 16.27 | 8.72 | <50 | <0.5 | <0.5 | <0.5 | <0.5 | <5.0 | |
| 1/17/2008 | 15.10 | 9.89 | <50 | <0.5 | <0.5 | <0.5 | <0.5 | <5.0 | |
| 4/9/2008 | 15.96 | 9.03 | <50 | <0.5 | <0.5 | <0.5 | <0.5 | <5.0 | |
| 7/17/2008 | 16.44 | 8.55 | <50 | <0.5 | <0.5 | <0.5 | <0.5 | <5.0 | |
| 10/27/2008 | 16.78 | 8.21 | <50 | <0.5 | <0.5 | <0.5 | <0.5 | <5.0 | |
| 1/9/2009 | 16.75 | 8.24 | <50 | <0.5 | <0.5 | <0.5 | <0.5 | <5.0 | |
| 4/27/2009 | 16.21 | 8.78 | -- | -- | -- | -- | -- | -- | |
| 7/9/2009 | 16.48 | 8.51 | -- | -- | -- | -- | -- | -- | |
| 2/3/2010 | 15.77 | 9.22 | <50 | <0.5 | <0.5 | <0.5 | <0.5 | <5.0 | |
| 7/13/2010 | 15.34 | 9.65 | --- | --- | --- | --- | --- | --- | |
| 1/17/2011 | 14.93 | 10.06 | <50 | <0.5 | <0.5 | <0.5 | <0.5 | <5.0 | |
| 7/12/2011 | 14.81 | 10.18 | -- | -- | -- | -- | -- | -- | |
| 1/11/2012 | 15.44 | 9.55 | <50 | <0.5 | <0.5 | <0.5 | <0.5 | <5.0 | |
| 7/25/2012 | 14.79 | 10.20 | -- | -- | -- | -- | -- | -- | |
| 1/25/2013 | 15.21 | 9.78 | <50 | <0.5 | <0.5 | <0.5 | <0.5 | <5.0 | |

PANGEA

Table 2 - Groundwater Elevation and Analytical Data.
Douglas Parking Company, 1721 Webster Street, Oakland, California

| Boring / Well ID TOC | Date | Depth to Water (ft) | Groundwater Elevation (ft amsl) | Groundwater Concentrations (µg/L) | | | | | |
|----------------------------|------------------|---------------------------|---------------------------------------|-----------------------------------|----------------|----------------|----------------|----------------|----------------|
| | | | | TPHg | Benzene | Toluene | Ethylbenzene | Xylenes | MTBE |
| MW-6 30.99 | 6/30/2003 | 19.60 | 11.39 | 68,000 | 950 | 6,000 | 2,400 | 10,000 | <1,000 |
| | 7/21/2003 | 19.67 | 11.32 | 120,000 | 170 | 1,400 | 1,100 | 10,000 | <1,000 |
| | 10/2/2003 | 19.97 | 11.02 | 16,000 | 7.6 | 200 | 38 | 1,800 | <100 |
| | 1/15/2004 | 19.55 | 11.44 | 14,000 | 48 | 51 | 94 | 1,100 | <50 |
| | 4/5/2004 | 19.17 | 11.82 | 24,000 | 180 | 900 | 430 | 1,800 | <500 |
| | 8/9/2004 | 20.98 | 10.01 | 5,300 | 6.4 | 25 | 5.3 | 69 | <17 (<0.5) |
| | 10/7/2004 | 21.52 | 9.47 | 5,600 | 11 | 58 | 18 | 210 | <50 (<0.5) |
| | 2/7/2005 | 19.00 | 11.99 | 31,000 | 120 | 620 | 310 | 1,200 | <500 |
| | 4/5/2005 | 18.60 | 12.39 | 21,000 | 170 | 1,100 | 350 | 1,300 | <500 (<5.0) |
| | 7/6/2005 | 18.56 | 12.43 | 26,000 | 130 | 920 | 320 | 1,200 | <500 |
| | 10/10/2005 | 19.99 | 11.00 | 19,000 | 140 | 840 | 250 | 980 | <500 |
| | 1/26/2006 | 18.70 | 12.29 | 10,000 | 140 | 1,100 | 270 | 1,200 | <170 |
| | 4/10/2006 | 18.04 | 12.95 | 13,000 | 140 | 1,000 | 280 | 1,000 | <250 |
| | 7/6/2006 | 18.80 | 12.19 | 17,000 | 150 | 1,000 | 290 | 1,000 | <250 |
| | 10/26/2006 | 19.62 | 11.37 | 23,000 | 230 | 660 | 470 | 1,500 | <500 |
| | 1/19/2007 | 19.92 | 11.07 | 18,000 | 190 | 620 | 350 | 1,100 | <150 |
| | 4/17/2007 | 19.97 | 11.02 | 23,000 | 380 | 1,400 | 590 | 2,000 | <450 |
| | 7/6/2007 | 19.81 | 11.18 | 28,000 | 600 | 3,000 | 900 | 2,700 | <500 |
| | 10/15/2007 | 20.15 | 10.84 | 25,000 | 290 | 680 | 410 | 1,100 | <250 |
| | 10/15/2007 | 20.15 | 10.84 | 25,000 | 290 | 680 | 410 | 1,100 | <250 |
| | 1/17/2007 | 20.22 | 10.77 | 16,000 | 200 | 130 | 130 | 460 | <150 |
| | 4/9/2008 | 19.86 | 11.13 | 18,000 | 320 | 870 | 480 | 1,500 | <250 |
| | 7/17/2008 | 20.36 | 10.63 | 18,000 | 320 | 510 | 420 | 1,200 | <500 |
| | 10/27/2008 | 20.69 | 10.30 | 31,000 | 320 | 320 | 410 | 990 | <350 |
| | 1/9/2009 | 20.83 | 10.16 | 22,000 | 340 | 390 | 560 | 1,400 | <250 |
| | 4/27/2009 | 20.27 | 10.72 | 13,000 | 110 | 97 | 380 | 1,100 | <350 |
| | 7/9/2009 | 20.43 | 10.56 | 18,000 | 250 | 520 | 470 | 1,300 | <450 |
| | 2/3/2010 | 20.14 | 10.85 | 6,200 | 82 | 180 | 190 | 550 | <150 |
| | 7/13/2010 | 19.29 | 11.70 | 12,000 | 260 | 420 | 480 | 1,600 | <450 |
| | 1/17/2011 | 19.31 | 11.68 | 4,900 | 70 | 52 | 210 | 500 | <50 |
| 7/12/2011 | 18.73 | 12.26 | 1,400 | 20 | 8.5 | 64 | 130 | <30 | |
| 1/11/2012 | 19.39 | 11.60 | 6,000 | 100 | 38 | 310 | 700 | <210 | |
| 7/25/2012 | 19.02 | 11.97 | 2,800 | 31 | 13 | 140 | 240 | <75 | |
| | 1/25/2013 | 19.35 | 11.64 | 5,400 | 86 | 34 | 310 | 620 | <100 |
| MW-7 33.11 | 6/30/2003 | 21.40 | 11.71 | 170 | <0.5 | 2.1 | 2.0 | 8.7 | <5.0 |
| | 7/21/2003 | 21.44 | 11.67 | <50 | <0.5 | <0.5 | <0.5 | <0.5 | <5.0 |
| | 10/2/2003 | 21.73 | 11.38 | <50 | <0.5 | <0.5 | <0.5 | <0.5 | <5.0 |
| | 1/15/2004 | 21.57 | 11.54 | <50 | <0.5 | <0.5 | <0.5 | <0.5 | <5.0 |
| | 4/5/2004 | 20.84 | 12.27 | <50 | <0.5 | <0.5 | <0.5 | <0.5 | <5.0 |
| | 8/9/2004 | 22.68 | 10.43 | <50 | <0.5 | <0.5 | <0.5 | <0.5 | <5.0 |
| | 10/7/2004 | 23.27 | 9.84 | <50 | <0.5 | <0.5 | <0.5 | <0.5 | <5.0 |
| | 2/7/2005 | 20.60 | 12.51 | <50 | <0.5 | <0.5 | <0.5 | <0.5 | <5.0 |
| | 4/5/2005 | 20.22 | 12.89 | <50 | <0.5 | 0.75 | <0.5 | <0.5 | <5.0 (<0.5) |
| | 7/6/2005 | 20.25 | 12.86 | <50 | <0.5 | <0.5 | <0.5 | <0.5 | <5.0 |
| | 10/10/2005 | 20.70 | 12.41 | <50 | <0.5 | <0.5 | <0.5 | <0.5 | <5.0 |
| | 1/26/2006 | 20.32 | 12.79 | <50 | <0.5 | <0.5 | <0.5 | <0.5 | <5.0 |
| | 4/10/2006 | 19.62 | 13.49 | <50 | <0.5 | <0.5 | <0.5 | <0.5 | <5.0 |
| | 7/6/2006 | 20.47 | 12.64 | <50 | <0.5 | <0.5 | <0.5 | <0.5 | <5.0 |
| | 10/26/2006 | 21.30 | 11.81 | <50 | <0.5 | <0.5 | <0.5 | <0.5 | <5.0 |
| | 1/19/2007 | 21.62 | 11.49 | <50 | <0.5 | <0.5 | <0.5 | <0.5 | <5.0 |
| | 4/17/2007 | | 11.49 | <50 | <0.5 | <0.5 | <0.5 | <0.5 | <5.0 |
| | 7/6/2007 | 21.59 | 11.52 | <50 | <0.5 | <0.5 | <0.5 | <0.5 | <5.0 |
| | 10/15/2007 | 21.85 | 11.26 | <50 | <0.5 | <0.5 | <0.5 | <0.5 | <5.0 |
| | 1/17/2007 | 21.90 | 11.21 | <50 | <0.5 | <0.5 | <0.5 | <0.5 | <5.0 |
| | 4/9/2008 | 21.61 | 11.50 | <50 | <0.5 | <0.5 | <0.5 | <0.5 | <5.0 |
| | 7/17/2008 | 22.09 | 11.02 | <50 | <0.5 | <0.5 | <0.5 | <0.5 | <5.0 |
| | 10/27/2008 | 22.39 | 10.72 | <50 | <0.5 | <0.5 | <0.5 | <0.5 | <5.0 |
| | 1/9/2009 | 22.52 | 10.59 | <50 | <0.5 | <0.5 | <0.5 | <0.5 | <5.0 |
| | 4/27/2009 | 21.98 | 11.13 | -- | -- | -- | -- | -- | -- |
| | 7/9/2009 | 22.18 | 10.93 | -- | -- | -- | -- | -- | -- |
| | 2/3/2010 | 21.87 | 11.24 | <50 | <0.5 | <0.5 | <0.5 | <0.5 | <5.0 |
| | 7/13/2010 | 21.01 | 12.10 | --- | --- | --- | --- | --- | --- |
| | 1/17/2011 | 21.07 | 12.04 | <50 | <0.5 | <0.5 | <0.5 | <0.5 | <5.0 |
| | 7/12/2011 | 20.72 | 12.39 | <50 | <0.5 | <0.5 | <0.5 | <0.5 | <5.0 |
| 1/11/2012 | 21.13 | 11.98 | <50 | <0.5 | <0.5 | <0.5 | <0.5 | <5.0 | |
| 7/25/2012 | 20.75 | 12.36 | -- | -- | -- | -- | -- | -- | |
| | 1/25/2013 | 21.10 | 12.01 | <50 | <0.5 | <0.5 | <0.5 | <0.5 | <5.0 |

PANGEA

Table 2 - Groundwater Elevation and Analytical Data.
Douglas Parking Company, 1721 Webster Street, Oakland, California

| Boring / Well ID TOC | Date | Depth to Water (ft) | Groundwater Elevation (ft amsl) | TPHg | Benzene | Toluene | Ethylbenzene (µg/L) | Xylenes | MTBE |
|-------------------------|------------|---------------------|---------------------------------|---------|---------|---------|---------------------|---------|------|
| AS-1 | 7/6/2006 | 19.53 | -- | 18,000 | 2,700 | 570 | 700 | 1,900 | <500 |
| | 10/26/2006 | 20.33 | -- | 15,000 | 1,900 | 340 | 360 | 1,400 | <250 |
| | 1/19/2007 | 20.64 | -- | 5,700 | 1,100 | 110 | 88 | 630 | <50 |
| | 1/19/2007 | 20.64 | -- | 5,700 | 1,100 | 110 | 88 | 630 | <50 |
| | 4/17/2007 | 20.71 | -- | -- | -- | -- | -- | -- | -- |
| | 7/16/2007 | -- | -- | -- | -- | -- | -- | -- | -- |
| | 10/15/2007 | -- | -- | -- | -- | -- | -- | -- | -- |
| | 1/17/2008 | -- | -- | -- | -- | -- | -- | -- | -- |
| | 4/9/2008 | -- | -- | -- | -- | -- | -- | -- | -- |
| | 1/25/2013 | -- | -- | 70 | 10 | <0.5 | <0.5 | <0.5 | <5.0 |
| AS-2 | 7/6/2006 | 22.26 | -- | 2,100 | 6.1 | <0.5 | 33 | 200 | <20 |
| | 10/26/2006 | 23.25 | -- | 280 | 1.1 | <0.5 | <0.5 | 6.0 | <15 |
| | 1/19/2007 | 23.61 | -- | 2,100 | 2.3 | <0.5 | 96 | 310 | <35 |
| | 4/17/2007 | 23.70 | -- | -- | -- | -- | -- | -- | -- |
| | 7/16/2007 | -- | -- | -- | -- | -- | -- | -- | -- |
| | 10/15/2007 | -- | -- | -- | -- | -- | -- | -- | -- |
| | 1/17/2008 | -- | -- | -- | -- | -- | -- | -- | -- |
| | 4/9/2008 | -- | -- | -- | -- | -- | -- | -- | -- |
| | 1/25/2013 | 22.02 | -- | <50 | <0.5 | <0.5 | <0.5 | <0.5 | <5.0 |
| | AS-3 | 7/6/2006 | 21.77 | -- | <50 | <0.5 | <0.5 | <0.5 | <0.5 |
| 10/26/2006 | | 22.66 | -- | <50 | <0.5 | <0.5 | <0.5 | <0.5 | <5.0 |
| 1/19/2007 | | 22.97 | -- | <50 | <0.5 | <0.5 | <0.5 | <0.5 | <5.0 |
| 4/17/2007 | | 23.06 | -- | -- | -- | -- | -- | -- | -- |
| 7/16/2007 | | -- | -- | -- | -- | -- | -- | -- | -- |
| 10/15/2007 | | -- | -- | -- | -- | -- | -- | -- | -- |
| 1/17/2008 | | -- | -- | -- | -- | -- | -- | -- | -- |
| 4/9/2008 | | -- | -- | -- | -- | -- | -- | -- | -- |
| 1/25/2013 | | 22.60 | -- | <50 | <0.5 | <0.5 | 0.55 | <0.5 | <5.0 |
| Trip Blank | | 01/12/01 | - | - | <50 | <0.5 | <0.5 | <0.5 | <0.5 |
| | 4/11/2001 | - | - | <50 | <0.5 | <0.5 | <0.5 | <0.5 | <5.0 |
| | 7/6/2001 | - | - | <50 | <0.5 | <0.5 | <0.5 | <0.5 | <5.0 |
| | 3/4/2002 | - | - | <50 | <0.5 | <0.5 | <0.5 | <0.5 | <5.0 |
| | 10/2/2003 | - | - | <50 | <0.5 | <0.5 | <0.5 | <0.5 | <5.0 |
| | 10/15/2007 | -- | -- | -- | -- | -- | -- | -- | -- |
| Grab Groundwater | | | | | | | | | |
| SB-A | 2/22/1996 | -- | -- | 16,000 | 38 | 16 | 180 | 620 | -- |
| SB-B | 2/22/1996 | -- | -- | 20,000 | 100 | 29 | 320 | 590 | -- |
| SB-C | 2/22/1996 | -- | -- | 1,200 | 130 | 100 | 68 | 230 | -- |
| SB-D | 2/22/1996 | -- | -- | 7,400 | 550 | 110 | 160 | 89 | -- |
| SB-E | 2/23/1996 | -- | -- | 16,000 | 31 | 160 | 390 | 1,400 | -- |
| SB-F | 2/23/1996 | -- | -- | <50 | <0.5 | 1.4 | <0.5 | 2.3 | -- |
| SB-G | 2/23/1996 | -- | -- | 5,200 | 1.3 | <0.5 | 0.7 | <0.5 | -- |
| EB-1GWS | 7/8/1994 | -- | -- | 62,000 | <0.5 | 26 | 850.0 | 8,900 | -- |
| EB-2GWS | 7/8/1994 | -- | -- | 160,000 | 5,300 | 20,000 | 2,100 | 17,000 | -- |
| EB-3GWS | 7/8/1994 | -- | -- | 87,000 | 1,400 | 21,000 | 1,700 | 19,000 | -- |
| EB-4GWS | 7/8/1994 | -- | -- | 350,000 | 290 | 1,300 | 3,200 | 31,000 | -- |
| EB-5GWS | 7/8/1994 | -- | -- | 120,000 | 2,100.0 | 13,000 | 1,300.0 | 16,000 | -- |
| EB-6GWS | 7/8/1994 | -- | -- | 230,000 | 10,000 | 34,000 | 2,300 | 16,000 | -- |

Notes and Abbreviations:

TOC = Top of casing elevations in feet above mean sea level.

ft amsl = Measured in feet above mean sea level

µg/L = Micrograms per liter.

TPHg = Total petroleum hydrocarbons as gasoline by modified EPA Method 8015C.

BTEX = Benzene, toluene, ethylbenzene, and xylenes by EPA Method 8021B.

MTBE = Methyl tertiary butyl ether by EPA Method 8021B, and by EPA Method 8260 in parenthesis.

<0.5 = Concentration not detected above specific laboratory reporting limit.

-- = Not analyzed, not sampled, or not applicable.

ND = Not detected.

Data prior to 7/11/95 from Gen Tech and Piers Environmental Quarterly Groundwater Monitoring Reports dated December 2, 1994 and March 6, 1995, respectively.

On July 31, 2003, Virgil Chavez Land Surveying of Vallejo, California surveyed monitoring wells using a benchmark in the top of the curb near the SW return of the NW corner of 34th and Broadway.

APPENDIX A

Regulatory Correspondence

Bob Clark-Riddell

From: Jakub, Barbara, Env. Health [barbara.jakub@acgov.org]
Sent: Tuesday, May 28, 2013 1:57 PM
To: 'lee@douglasparking.com'
Cc: Bob Clark-Riddell; Roe, Dilan, Env. Health; dehloptoxic, Env. Health
Subject: RO129, Douglas Parking

Mr. Douglas,

Alameda County Environmental Health (ACEH) staff has reviewed the case file including the *Workplan for Additional Assessment and Soil Gas Sampling*, dated April 4, 2013, which was prepared by Pangea for the subject site. The work plan recommends advancing two soil borings, one soil vapor monitoring well and three sub-slab points to address remaining data gaps.

ACEH has evaluated the data and recommendations presented in the above-mentioned report, in conjunction with the case files, and the State Water Resources Control Board's (SWRCBs) Low Threat Underground Storage Tank Case Closure Policy (LTCP). Based on ACEH staff review, we have determined that the site fails to meet the LTCP Media-Specific Criteria for Vapor Intrusion to Indoor Air, and the Media-Specific Criteria for Direct Contact.

Therefore, at this juncture ACEH requests that you prepare a Revised Data Gap Investigation Work Plan to evaluate the remaining data gaps identified in the May 28, 2013 meeting with Robert Clark Riddell of Pangea, Dilan Roe and Barbara Jakub of Alameda County Environmental Health for the criteria specified above.

As discussed in the meeting please prepare a scope of work for the following items:

- Present a strategy to evaluate soil concentrations near the previously collected underground storage tank (UST) confirmation samples with elevated detections of benzene to verify that residual contamination does not pose a threat to human occupants due to vapor intrusion into buildings. As discussed in the meeting, please adjust the proposed soil vapor well/sub-slab locations to serve a dual purpose of confirming (1) that secondary source has been removed to the extent practicable via remediation previously conducted at the site, and (2) that soil vapor does not pose a risk to on- and off-site building occupants.
- Present a strategy to collect and analyze soil samples in the upper ten feet to satisfy the direct contact and outdoor air criteria. As discussed in the meeting, please also collect TPH data from the same borings to characterize the bioattenuation zone and thereby provide an alternate line of evidence to verify that vapor intrusion is not an issue at this site and therefore, possibly preclude the need for additional seasonal soil vapor data to satisfy.
- Update the soil vapor sampling procedures to reflect naphthalene analysis by Method TO-17 in accordance with DTSC 2011 guidance.

Please submit the requested work plan by June 28, 2012.

Barbara Jakub, P.G.
Hazardous Materials Specialist
Alameda County Environmental Health
1131 Harbor Bay Pky.
Alameda, CA 94502
Direct: 510-639-1287
Fax: 510-337-9335

PDF copies of case files can be downloaded at:

<http://ehgis.acgov.org/dehpublic/dehpublic.jsp>

APPENDIX B

Standard Operating Procedures

STANDARD FIELD PROCEDURES FOR HAND-AUGER SOIL BORINGS

This document describes Pangea Environmental Services' standard field methods for drilling and sampling soil borings using a hand-auger. These procedures are designed to comply with Federal, State and local regulatory guidelines. Specific field procedures are summarized below.

Objectives

Soil samples are collected to characterize subsurface lithology, assess whether the soils exhibit obvious hydrocarbon or other compound vapor odor or staining, estimate ground water depth and quality, and to submit samples for chemical analysis.

Soil Classification/Logging

All soil samples are classified according to the Unified Soil Classification System by a trained geologist or engineer working under the supervision of a California Registered Geologist (RG), Certified Engineering Geologist (CEG), or Professional Engineer. The following soil properties are noted for each soil sample:

- Principal and secondary grain size category (i.e. sand, silt, clay or gravel)
- Approximate percentage of each grain size category,
- Color,
- Approximate water or product saturation percentage,
- Observed odor and/or discoloration,
- Other significant observations (i.e. cementation, presence of marker horizons, mineralogy), and
- Estimated permeability.

Soil Boring and Sampling

Hand-auger borings are typically drilled using a hand-held bucket auger to remove soil to the desired sampling depth. Samples are collected using lined split-barrel or equivalent samplers driven into undisturbed sediments beyond the bottom of the augered hole. The vertical location of each soil sample is determined using a tape measure. All sample depths use the ground surface immediately adjacent to the boring as a datum. The horizontal location of each boring is measured in the field from an onsite permanent reference using a measuring wheel or tape measure.

Augering and sampling equipment is steam-cleaned or washed prior to drilling, between samples and between borings to prevent cross-contamination withalconox/liquinox or an equivalent EPA-approved detergent.

Sample Storage, Handling and Transport

Sampling tubes chosen for analysis are trimmed of excess soil and capped with Teflon tape and plastic end caps. Soil samples are labeled and stored at or below 4°C on either crushed or dry ice, depending upon local regulations. Samples are transported under chain-of-custody to a State-certified analytic laboratory.

Field Screening

One of the remaining tubes is partially emptied into a re-sealable plastic bag. The bag of soil is placed in the sun to allow hydrocarbons to volatilize from the soil. After ten to fifteen minutes, a portable photoionization detector (PID) measures volatile hydrocarbon vapor concentrations in the bag headspace, extracting the vapor through a slit in the bag. PID measurements are used along with the field observations, odors, stratigraphy and ground water depth to select soil samples for analysis.

Water Sampling

Water samples, if they are collected from the boring, are collected from screened PVC casing installed in the hole or from the open borehole using bailers. The ground water samples are decanted into the appropriate containers supplied by the analytic laboratory. Samples are labeled, placed in re-sealable plastic bags, stored on crushed ice at or below 4°C, and transported under chain-of-custody to the laboratory.

Duplicates and Blanks

Blind duplicate water samples are usually collected only for monitoring well sampling programs, at a rate of one blind sample for every 10 wells sampled. Laboratory-supplied trip blanks can be used to check for cross-contamination caused by sample handling and transport. These trip blanks are analyzed if the internal laboratory QA/QC blanks contain the suspected field contaminants. An equipment blank sample may also be analyzed if non-dedicated sampling equipment is used.

Grouting

The borings are filled to the ground surface with cement grout poured or pumped through a tremie pipe.

Waste Handling and Disposal

Soil cuttings from drilling activities are usually stockpiled onsite on top of and covered by plastic sheeting. At least four individual soil samples are collected from the stockpiles for later compositing at the analytic laboratory. The composite sample is analyzed for the same constituents analyzed in the borehole samples. Soil cuttings are transported by licensed waste haulers and disposed in secure, licensed facilities based on the composite analytic results.

Ground water removed during sampling and/or rinsate generated during decontamination procedures are stored onsite in sealed 55-gallon drums. Each drum is labeled with the drum number, date of generation, suspected contents, generator identification and consultant contact. Disposal of the water is based on the analytic results for the well samples. The water is either pumped out using a vacuum truck for transport to a licensed waste treatment/disposal facility or the individual drums are picked up and transported to the waste facility where the drum contents are removed and appropriately disposed.

STANDARD FIELD PROCEDURES FOR SOIL BORINGS

This document describes Pangea Environmental Services' standard field methods for drilling and sampling soil borings. These procedures are designed to comply with Federal, State and local regulatory guidelines. Specific field procedures are summarized below.

Objectives

Soil samples are collected to characterize subsurface lithology, assess whether the soils exhibit obvious hydrocarbon or other compound vapor odor or staining, estimate ground water depth and quality, and to submit samples for chemical analysis.

Soil Classification/Logging

All soil samples are classified according to the Unified Soil Classification System by a trained geologist, scientist or engineer working under the supervision of a California Registered Engineer, California Registered Geologist (RG) or a Certified Engineering Geologist (CEG). The following soil properties are noted for each soil sample:

- Principal and secondary grain size category (i.e. sand, silt, clay or gravel)
- Approximate percentage of each grain size category,
- Color,
- Approximate water or product saturation percentage,
- Observed odor and/or discoloration,
- Other significant observations (i.e. cementation, presence of marker horizons, mineralogy), and
- Estimated permeability.

Soil Boring and Sampling

Soil borings are typically drilled using hollow-stem augers or hydraulic-push technologies. At least one and one half ft of the soil column is collected for every five ft of drilled depth. Additional soil samples are collected near the water table and at lithologic changes. With hollow-stem drilling, samples are collected using lined split-barrel or equivalent samplers driven into undisturbed sediments beyond the bottom of the borehole. With hydraulic-push drilling, samples are typically collected using acetate liners. The vertical location of each soil sample is determined by measuring the distance from the middle of the soil sample tube to the end of the drive rod used to advance the split barrel sampler or the acetate tube. All sample depths use the ground surface immediately adjacent to the boring as a datum. The horizontal location of each boring is measured in the field from an onsite permanent reference using a measuring wheel or tape measure.

Drilling and sampling equipment is steam-cleaned prior to drilling and between borings to prevent cross-contamination. Sampling equipment is washed between samples with trisodium phosphate or an equivalent EPA-approved detergent.

Sample Storage, Handling and Transport

Sampling tubes or cut acetate liners chosen for analysis are trimmed of excess soil and capped with Teflon tape and plastic end caps. Soil samples are labeled and stored at or below 4°C on either crushed or dry ice, depending upon local regulations. Samples are transported under chain-of-custody to a State-certified analytic laboratory.

Field Screening

Soil samples collected during drilling will be analyzed in the field for ionizable organic compounds using a photo-ionization detector (PID) with a 10.2 eV lamp. The screening procedure will involve placing an undisturbed soil sample in a sealed container (either a zip-lock bag, glass jar, or a capped soil tube). The container will be set aside, preferably in the sun or warm location. After approximately fifteen minutes, the head space within the container will be tested for total organic vapor, measured in parts per million on a volume to volume basis (ppmv) by the PID. The PID instrument will be calibrated prior to boring using hexane or isobutylene. PID measurements are used along with the field observations, odors, stratigraphy and ground water depth to select soil samples for analysis.

Water Sampling

Water samples collected from borings are either collected from the open borehole, from within screened PVC inserted into the borehole, or from a driven Hydropunch-type sampler. Groundwater is typically extracted using a bailer, check valve and/or a peristaltic pump. The ground water samples are decanted into the appropriate containers supplied by the analytic laboratory. Samples are labeled, placed in protective foam sleeves, stored on crushed ice at or below 4°C, and transported under chain-of-custody to the laboratory.

Pangea often performs electrical conductivity (EC) logging and/or continuous coring to identify potential water-bearing zones. Hydropunch-type sampling is then performed to provide discrete-depth grab groundwater sampling within potential water-bearing zones for vertical contaminant delineation. Hydropunch-type sampling typically involves driving a cylindrical sheath of hardened steel with an expendable drive point to the desired depth within undisturbed soil. The sheath is retracted to expose a stainless steel or PVC screen that is sealed inside the sheath with Neoprene O-rings to prevent infiltration of formation fluids until the desired depth is attained. The groundwater is extracted using tubing inserted down the center of the rods into the screened sampler.

Duplicates and Blanks

Blind duplicate water samples are usually collected only for monitoring well sampling programs, at a rate of one blind sample for every 10 wells sampled. Laboratory-supplied trip blanks accompany samples collected for all sampling programs to check for cross-contamination caused by sample handling and transport. These trip blanks are analyzed if the internal laboratory QA/QC blanks contain the suspected field contaminants. An equipment blank may also be analyzed if non-dedicated sampling equipment is used.

Grouting

If the borings are not completed as wells, the borings are filled to the ground surface with cement grout poured or pumped through a tremie pipe.

Waste Handling and Disposal

Soil cuttings from drilling activities are usually stockpiled onsite on top of and covered by plastic sheeting. At least four individual soil samples are collected from the stockpiles for later compositing at the analytic laboratory. The composite sample is analyzed for the same constituents analyzed in the borehole samples. Soil cuttings are transported by licensed waste haulers and disposed in secure, licensed facilities based on the composite analytic results.

Ground water removed during sampling and/or rinsate generated during decontamination procedures are stored onsite in sealed 55 gallon drums. Each drum is labeled with the drum number, date of generation, suspected contents, generator identification and consultant contact. Disposal of the water is based on the analytic results for the well samples. The water is either pumped out using a vacuum truck for transport to a licensed waste treatment/disposal facility or the individual drums are picked up and transported to the waste facility where the drum contents are removed and appropriately disposed.

STANDARD OPERATING PROCEDURE FOR SUBSLAB VAPOR SAMPLING

1.0 PURPOSE

This standard operating procedure (SOP) describes the procedures for collecting subsurface vapor samples using evacuated stainless-steel Summa canisters (TO-15) or sorbent tubes (TO-17) for the purpose of assessing risk to building occupants. The SOP is modified from procedures and information presented in Cal/EPA 2012 (*Advisory-Active Soil Investigations*); Cal/EPA 2011; Cal/EPA 2010; U.S. EPA, 2006; DiGiulio, 2003; and U.S. EPA 1999. This SOP includes (a) real-time leak-check procedures to evaluate integrity of the soil gas probe and sampling assembly during probe purging and post sampling, and (b) real-time field screening of soil gas concentrations during probe purging and post sampling.

2.0 REQUIRED EQUIPMENT

- Hammer drill with 1” bit and smaller bits (slightly larger than vapor probe tubing)
- Tubing for cleaning boring
- Stainless-steel or Teflon vapor probe tubing with Swagelok threaded compression fitting, vapor-tight cap, and valves.
- Rubber stopper or Teflon disk
- Granulated bentonite, bentonite pellets and cement
- Vacuum pump with adjustable rotameter for purging and leak testing
- 1-Liter Summa canister for each sample
- Stainless-steel sampling manifold with vacuum gauges and critical orifice flow restrictor (request that laboratory leak-check sampling manifold prior to mobilization)
- Leak-check compound (e.g. helium)
- Helium gas analyzer (calibrated)
- Calibrated photoionization detector (PID) or other organic vapor analyzer
- Isobutylene for PID calibration
- Tedlar bags (for helium measurement and vapor screening)
- Vacuum chamber (iron lung) for pre- and post-sampling leak-check
- Leak-check enclosure (bucket with hydrated bentonite pellets [or weather stripping] for sealing enclosure to surface and openings for vapor probe tubing, helium and for sampling enclosure atmosphere)
- Recordkeeping materials
- Latex or nitrile gloves

3.0 PROCEDURES

3.1 Boring Clearance

Prior to installing subsurface vapor probes, ensure that a utility clearance has been conducted to ensure that potential subsurface utility and rebar locations have been identified and marked.

3.2 Vapor Probe Construction

1. To protect interior surfaces, lay plastic sheeting around the probe location.
2. Use a rotary hammer drill to create an approximately 3-inch deep, 1 1/2 -inch diameter hole that *partially* penetrates the slab. Use a piece of flexible tubing to blow or vacuum concrete debris and dust from the hole. Do not blow or vacuum after the slab has been completely penetrated.
3. Drill a smaller diameter *inner hole* in the center of the outer hole, periodically blowing dust and debris from the hole until the slab is penetrated. The diameter of the inner hole should exceed the diameter of the vapor probe tubing by the minimum amount practicable. The inner hole should be drilled completely through the slab and 3 to 4 inches into the subslab material (baselock or soil) to form a cavity (**Figure 1**).
4. Insert the capped vapor probe tubing through a tightly fitting rubber stopper or a Teflon disk and insert the stopper or disk into the bottom of the outer hole. The purpose of the stopper is to stop moisture from the annular seal from leaking into subslab materials. The fitting may either be constructed flush, or may protrude above the slab, depending on location and susceptibility to damage. If a lubricant is needed, use only high-vacuum silicone grease.
5. Clean the concrete surfaces in the borehole with a dampened towel to increase the potential of a good seal. Fill the remainder of the hole with hydrated bentonite (temporary probe) or hydrated bentonite topped with expanding cement (semi-permanent probe). Place a protective cap (temporary probe) or flush mounted well box (semi-permanent probe) over the probe to protect it from damage.

3.3 Vapor Sampling Using Method TO-15

During vapor sampling, record all valve open/close times and canister/manifold vacuum readings at each step. Do not conduct sampling within **5 days following a significant rain event** (0.5 inches of rainfall during any 24-hour period) or significant irrigation adjacent to the building.

Setup

1. Calculate and record the volume of the sampling assembly, tubing, vapor probe and void space created in subslab material.

$$\text{Volume} = \pi * r^2 * L = 3.14 \times (1/2 * \text{ID}) \times (1/2 * \text{ID}) * L,$$

where ID = cavity, tubing or manifold inside diameter and L = length of cavity or tubing/manifold segment.

2. Wear latex or nitrile gloves while handling sampling equipment. Change gloves whenever a new sample is collected and after handling leak-check compound.
3. Replace the vapor probe cap with a closed Swagelok valve. Connect the sampling manifold to the vapor probe, sample Summa canister and vacuum pump using Swagelok fittings and stainless-steel, Teflon or Tygon tubing. Check all fittings for tightness (do not overtighten).
4. Close all valves. Record pre-test vacuum readings on summa canister.

Manifold Shut-In Check

1. Open valve on vapor sampling manifold and open 3-way valve #1 so the vacuum pump of the purging assembly can evacuate the vapor sampling manifold assembly (keep valves #2 and #3 closed to the Tedlar bag/vacuum chamber of the vapor screening assembly) (**Figure 2**). Start the vacuum pump. Do *not* open #1 valve to the probe assembly, or the valve on the sample Summa canister. Allow manifold/tubing vacuum to stabilize at approximately 10" Hg.
2. Stop the vacuum pump, close 3-way valves #2 and #3 (to allow shut-in testing of vapor sampling manifold), and conduct a shut-in test by waiting at least **5 minutes** (if using 150 inches of water gauge) or **10 minutes** (if using 30 inches of mercury gauge). Monitor manifold vacuum gauge to test for leaks. If the vacuum decreases, rectify the leak before proceeding.

Purge, Flow and Leak Check

1. **Calculate purge volume and duration.** Determine the desired total purge volume and purging duration for the equipment setup. A critical orifice flow restrictor is intended to limit the maximum purge and sampling flow rate (approximately 150 ml/min). If step testing is not required to better determine optimal purge volume, **purge approximately 3 times** the volume of the sampling assembly, tubing, vapor probe and void space or any probe/filter pack material below the concrete slab.
2. **Leak-check enclosure.** Place leak-check enclosure over vapor probe and seal to floor using hydrated bentonite or weather stripping. Introduce helium gas into the leak-check enclosure and monitor with the helium gas analyzer until it reads between 20% and 30% helium.
3. **Conduct purging.** Start vacuum pump and open 3-way valve #1 (and 3-way valves #2 and #3) so the vacuum pump can evacuate the probe. Do *not* over-purge. Closely monitor the flow on the rotameter and the vacuum on the vacuum gauge. For most samples flow should be limited to 150mL/min or less. If the vacuum remains below approximately 7" Hg, then sufficient flow is present to collect a representative sample (Cal/EPA 2012) and continue purging for the planned purge duration.
4. If the probe-side vacuum exceeds approximately 7" Hg, then insufficient flow may be present to collect a representative sample and this condition should be noted. Evaluate probe integrity or consider re-installation of probe, especially if probe installed in coarse-grain material. If no significant flow is attained, the sampling line may be plugged or the vapor probe may be positioned in a low permeability or saturated layer. If the probe cap is opened for probe inspection, record the inspection procedures and duration. If purging and sampling is resumed after opening the probe cap, this information will help determine the representativeness of the sample. **To sample subslab gas under low flow conditions, follow this alternate sampling method** derived from Appendix D, Cal/EPA 2012. Make a reasonable attempt to purge one purge volume. After purging, open sample Summa canister until sampling manifold vacuum threshold is achieved, then close Summa sample valve until probe vacuum dissipates. Repeat this sampling procedure as necessary to sufficiently fill the sample Summa canister. Alternatively, consider installing a subslab gas probe with a larger probe annulus space, or employing passive soil gas sampling methods.
5. When purge duration complete and ready to discontinue purging, close 3-way valve #1 so that the probe is connected to the sampling manifold, and then stop the vacuum pump.
6. Record helium reading for leak-check enclosure at least once every minute during purging and sampling.

Sample Collection

1. **Opening Sample Canister.** Once a helium reading of at least 20% has been reached, open sample canister valve. **Sampling takes approximately 5 minutes for a 1-liter Summa canister** (at 150 ml/min sampling flow rate).
2. Close sampling canister valve when vacuum decreases to 5" mercury. Do *not* allow vacuum to fall below this range.
3. **Post-Sample Vapor Screening.** After sampling, open 3-way valve #1 so that the vapor screening assembly is connected to the probe, turn on the vacuum pump, and open 3-way valves #2 and #3 to partially fill the Tedlar bag within the vacuum chamber (iron lung). When Tedlar bag is sufficiently filled, return valves #2 and #3 to purging position. Check Tedlar bag for indication of sampling leakage using the helium gas analyzer. If helium concentration is below 1% then sample is sufficiently representative. If helium concentration is above 1%, then the sample may not be sufficiently representative; the probe may need to be repaired or re-installed and re-sampled. Additionally, check the Tedlar bag for contaminants using the PID for qualitative contaminant assessment (optional).
4. **Shroud Sample.** To confirm helium meter readings collect one shroud sample per day to analyze for percent helium. Connect the shroud sample summa canister and manifold to a port near the bottom of the shroud and open the canister valve at the beginning of sampling. Close sampling canister valve when vacuum decreases to 5" mercury. Do *not* allow vacuum to fall below this range. Disassemble sampling assembly, and cap (or remove and restore) vapor sampling point.
5. **Analyses.** Fill out chain-of-custody form for analysis for **chemicals of concern (i.e. TO-15)**, and for **leak-check compound** for at least 10% of samples. For naphthalene analysis, the analytical laboratory will utilize procedures for recovery, carryover, canister cleanliness, age, and matrix spikes and matrix spike duplicates as outlined in the *April 2012 Cal/EPA Advisory - Active Soil Gas Investigation*, Appendix E. Analyze all samples for **percent oxygen** by ASTM D1946-90. Additionally, samples may be analyzed for **percent methane and carbon dioxide** by ASTM D1946-90 when in support of sensitive human health risk assessments for regulatory review. Include final vacuum reading and serial numbers of canister and flow restrictor on chain-of-custody form.
6. For vapor sampling in support of sensitive human health risk assessments for regulatory review, collect at least one *duplicate* sample per site per sampling event from the sampling point with the anticipated highest vapor concentrations. The duplicate sample should be collected by attaching a fresh sample canister following collection of the initial sample. If a new manifold is used, follow the same purging and sampling procedures used for the original sample. If the same manifold is used, collect a sample without further purging, using the same sampling procedures used for the original sample.

Decontamination and Decommissioning

1. Use a decontaminated sampling manifold and new tubing for each sample location. Return equipment to laboratory for decontamination.
2. Backfill any open soil vapor probe holes with bentonite slurry or Portland cement and cap with concrete or other surface material to match the area.
3. To retain the subslab probe for future sampling, cap the Swagelock fitting and cover the probe with a small vault or other protective device.

3.4 Vapor Sampling Using Method TO-17

Required Equipment

- Swagelok sealed tubes packed with an appropriate sorbent material for the target compounds (confirm with sorbent tube supplier). Bring extra tubes for laboratory and field blanks (if merited).
- Air pump with mass flow monitor.
- Swagelok fittings with ferrules.
- ¼-inch diameter Teflon tubing.
- Isopropyl alcohol (IPA) and small jar with gauze pads (for leak-check compound)
- Photo-ionization detector (PID)
- Shroud with pass-through fitting for sample train and topside port for IPA monitoring.

Procedures

1. Use a Swagelok fitting to attach Teflon tubing to the probe. Place the small jar with isopropyl alcohol (IPA) near the probe and put the shroud over the probe and jar. Seal the shroud to the ground using weather stripping. Monitor the air inside the top of the shroud using the PID to check for sufficient IPA concentration.
2. Note that the IPA response factor is approximately 5.6 (i.e. a reading of 2 ppm on the PID indicates $5.6 \times 2 = 11.2$ ppm of IPA in the sample). Record both the observed PID reading and the calculated IPA. If the PID reading is below 10 ppm, slowly reapply leak-check compound.
3. Uncap and immediately reseal the required number of field blank tubes (optional).
4. Calibrate the pump using a “dummy” tube. Connect the sampling pump with mass flow monitor to the outlet of the “dummy” tube using a Swagelok fitting. The inlet of the “dummy tube” should be connected to the probe via Teflon tubing using a Swagelok connector.
5. Set the flow rate on the pump to the desired rate (typically 50mL/min). Leave the pump on for approximately one minute to establish the approximate flow rate. Record the flow rate on the data sheet.
6. Replace the “dummy” tube with the sampling tube(s) and adjust the flow rate to the desired rate quickly, and record flow rate and start time on the field data sheet.
7. Continue sampling for the pre-determined duration (typically 20 min for 1L sample). Recheck the flow rate at the end of the sampling period (i.e. 20 minutes) prior to turning off the pump and record the field data sheet.
8. After turning off the pump, immediately remove the sampling tube(s) and cap both ends with Swagelok fittings. Store the sampling tube(s) in sealable plastic bags on ice in an ice chest.
9. Note tube identification numbers, pump flow rates, dates, times, sampled volume (using the average of the pre and post flow rates) and ambient conditions on the data sheet. Submit this information to the laboratory with the samples.

REFERENCES

- Cal/EPA, 2012, Advisory-Active Soil Gas Investigation, California Environmental Protection Agency, Department of Toxic Substances Control, Los Angeles Regional Water Quality Control Board, San Francisco Regional Water Quality Control Board, April.
- Cal/EPA, 2011, Guidance for the evaluation and mitigation of subsurface vapor intrusion to indoor air (vapor intrusion guidance), California Environmental Protection Agency, Department of Toxic Substances Control, October).
- Cal/EPA, 2004, Interim final guidance for the evaluation and mitigation of subsurface vapor intrusion to indoor air, California Environmental Protection Agency, Department of Toxic Substances Control, December 15 (revised February 7, 2005).
- U.S. EPA, 2006, Office Of Research and Development, National Risk Management Research Laboratory, Cincinnati, OH, Assessment of vapor intrusion in homes near the Raymark Superfund Site using basement and sub-slab air samples, March.
- Dominic DiGiulio, 2003, Standard Operating Procedure (SOP) for installation of sub-slab vapor probes and sampling using EPA Method TO-15 to support vapor intrusion investigations, U.S. Environmental Protection Agency, Office of Research and Development, National Risk Management Research Laboratory, Ground-Water and Ecosystem Restoration Division, Ada, Oklahoma (included as Appendix C of Colorado Department of Public Health and Environment, 2004, Draft Indoor Air Guidance, Hazardous Materials and Waste Division), September.
- U.S. EPA, 1999, Office of Research and Development, National Risk Management Research Laboratory, Cincinnati, OH, Compendium of Methods for the Determination of Toxic Organic Compounds in Ambient Air Second Edition, January.

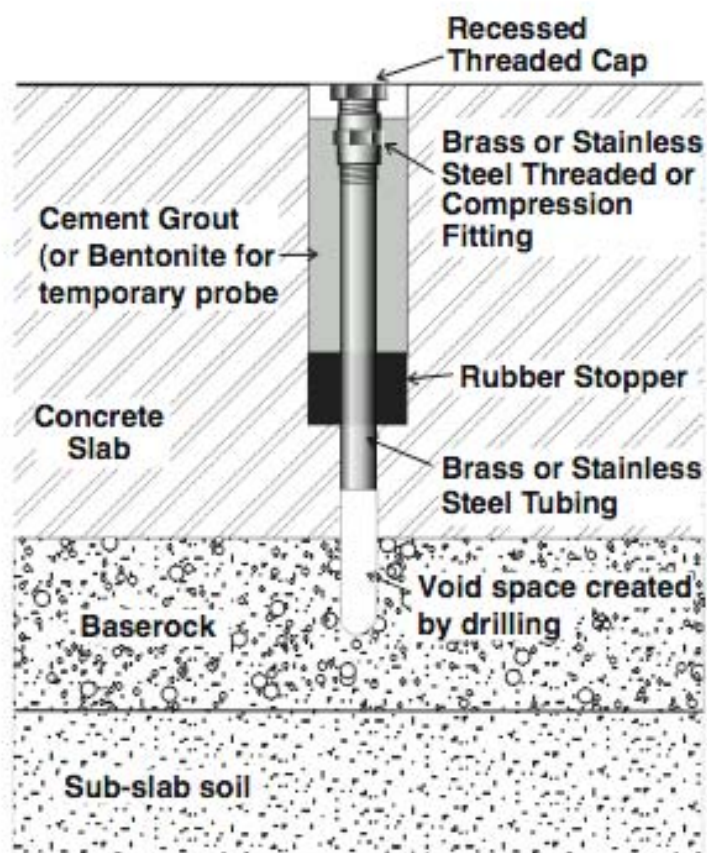



Figure

1

Subslab Vapor Probe Schematic



EXPLANATION

-  Vacuum Gauge
-  Three Way Valve
-  Valve
-  Swagelok Fitting
-  Air Tight Fitting

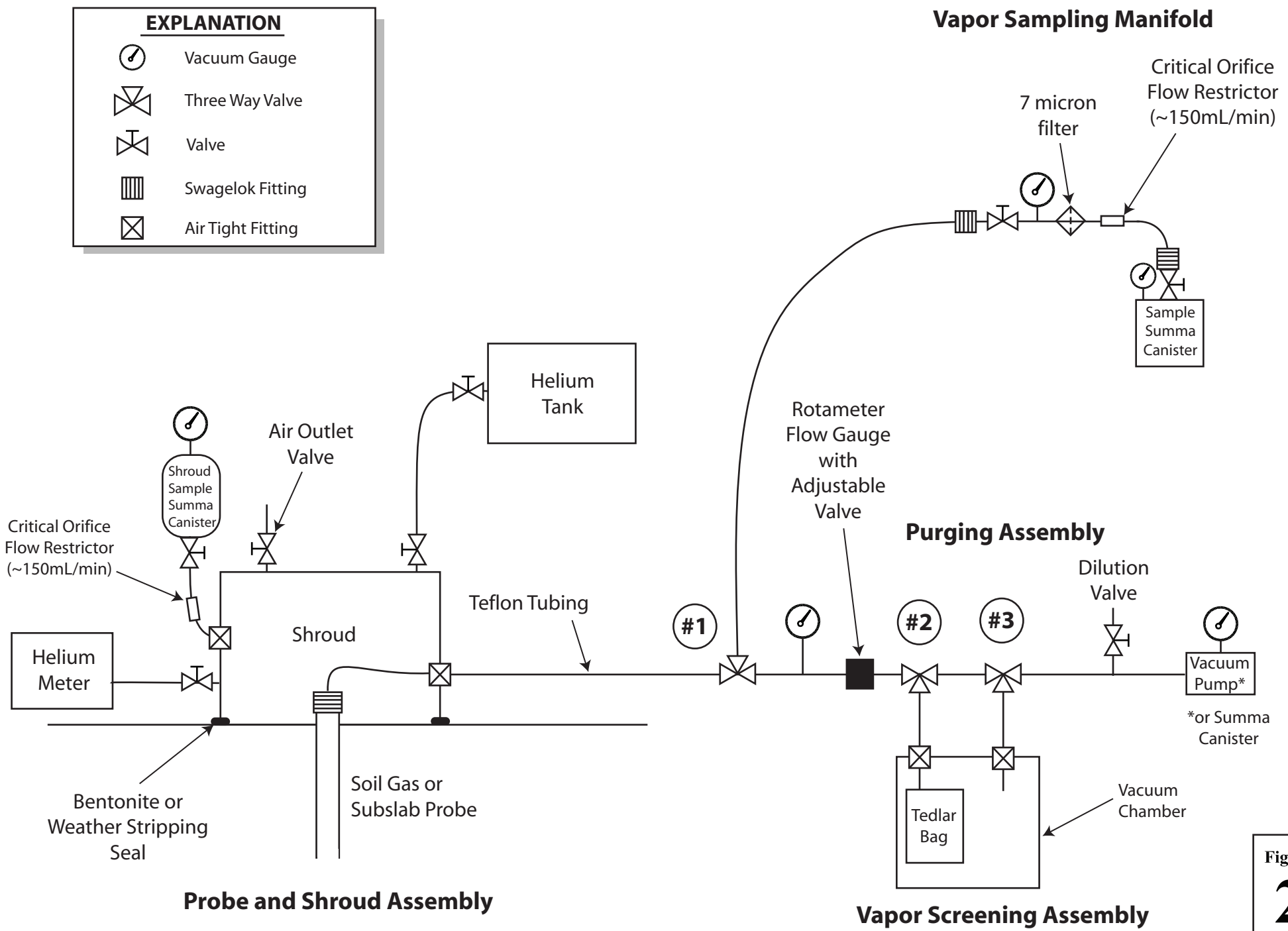

Figure 2