



**CERTIFIED
ENVIRONMENTAL
CONSULTING INC.**

**ALCO
HAZMAT**

93 NOV 15 PM 4:41

November 12, 1993

REF: 477-1369.WP

Mr. Barney M. Chan
Alameda County Health Care Services
Department of Environmental Health
80 Swan Way, Rm 200
Oakland, CA 94621

Handwritten notes:
Need to know
S + BTEX for 9000 EKC.
g.d., TOG, BTEX, Pb +
CHC (800) + method 8270
Semi-volatiles
H
3.82
Cautions 3 mws likely unless

SUBJECT: Work Plan for Remediation at Motor Partners, 1234 40th Avenue, Oakland, CA 94621

Dear Mr. Chan:

Certified Environmental Consulting, Inc. (CEC) is pleased to submit the enclosed Work Plan for remediation at the Motor Partners site located at 1234 40th Avenue in Oakland.

A detailed description of each task is provided in the attached work plan. The work includes; 1) researching the records of monitoring well sites nearby to determine the ground water depth and gradient, 2) evaluate soil sample data after completion of the re-excavation to determine if a monitoring well is justified, and 3) in the event that a monitoring well is required, the installation of the well, along with quarterly monitoring and reporting.

If you have questions, please give us a call. We are looking forward to working with you on this project.

Sincerely,

Handwritten signature: Gary Rogers
Handwritten number: 1-(415)341-7630

Gary Rogers, Ph.D.
District Manager

Handwritten signature: Stanley L. Klemetson

Stanley L. Klemetson, Ph.D., P.E.
Exec. Vice President

Enclosures

cc: Bill Owens. Motor Partners



ALCO
HAZMAT

WORK PLAN FOR REMEDIATION

93 NOV 15 PH 4: 41

PROJECT SITE

Motor Partners
1234 40th Avenue
Oakland, CA 94621

PREPARED FOR

Mr. Bill Owens
Motor Partners
2221 Olympic Blvd.
Walnut Creek, CA 94595
(510) 935-3840

SUBMITTED TO

Mr. Barney M. Chan
Alameda County Health Care Services
Department of Environmental Health
80 Swan Way, Rm 200
Oakland, CA 94621

PREPARED BY

Certified Environmental Consulting
32 West 25th Ave., Suite 102
San Mateo, CA 94403
(415) 341-7630
(415) 341-7652 FAX

CEC PROJECT NO.
477-1369

November 12, 1993

TABLE OF CONTENTS

INTRODUCTION	1
Project Description	1
Site Location and Description	1
Site History and Use	1
Previous Subsurface Investigations	1
Geology and Hydrogeology	5
SITE REMEDIATION	6
Notifications	6
Task 1 - Determination of GW Depth and Gradient	6
Task 2 - Re-excavation Sampling and Evaluation	6
Task 3 - Monitoring Well Installation	6
Task 4 - Quarterly Monitoring	9
Task 5 - Reporting	9
APPENDICES	10
A. Soil Sampling in Excavations.	10
B. Water Sampling in Wells and Boreholes.	12
C. Well Construction	16
D. Site Health and Safety Plan	24

LIST OF FIGURES

Figure 1. Site Location Map	2
Figure 2. Site Layout Map	3
Figure 3. Design Specifications for Monitoring Wells	8
Figure 4. Unified Soil Classification System	23
Figure 5. Route to Hospital	30

LIST OF TABLES

Table 1. Soil Sampling Data	4
---------------------------------------	---

INTRODUCTION

Project Description

The project will require the following tasks. First of all, the records of nearby monitoring well data will be researched to determine the depth to ground water as well as the ground water gradient. After completion of the re-excavation and soil sampling required for the two tank sites at 1234 40th Ave., the data will be re-evaluated to determine whether or not a monitoring well is justified. A monitoring well will be installed if it is required. The well will be installed within 10 ft. in the down gradient direction of the waste oil tank. After completion, the well will be monitored for four quarters over the period of one year to determine any impacts on local groundwater quality.

Site Location and Description

Motor Partners is located at 1234 40th Avenue near Nimitz Highway (880) in the Fruitvale District of Oakland, California (Figure 1). The BART rail tracks are about 500 ft. west of the site and San Leandro Bay is less than one mile to the southwest.

Site History and Use

Motor Partners utilized the site for auto repair shops. Two underground storage tanks were maintained outside the 1234 40th Ave. building. A 1,000-gallon underground gasoline tank and a 500-gallon underground waste oil tank were located below the sidewalk (Figure 2). No reliable records exist to determine if inventory was lost.

Previous Subsurface Investigations

On Oct. 12, 1990, Semco, Inc. of Modesto, California removed both the 1,000-gallon gasoline tank and the 500-gallon waste oil tank. The concentration of total petroleum hydrocarbons in the gasoline range (TPH-G) below the 1000-gallon tank was 1600 mg/Kg. The TPH-G and TPH-D concentrations below the 500-gallon tank were 570 mg/Kg and 650 mg/Kg, respectively. There was no record of groundwater in the excavations. The excavations were backfilled to grade with original spoils.

The analytical results (see Table 1 for summary of data and Appendix A for all of the laboratory results) for the site showed soil contamination remaining on-site. A work plan was prepared by SEMCO to reopen the excavation, remove the contaminated soil, and dispose of the contaminated backfill. This work has not been completed.

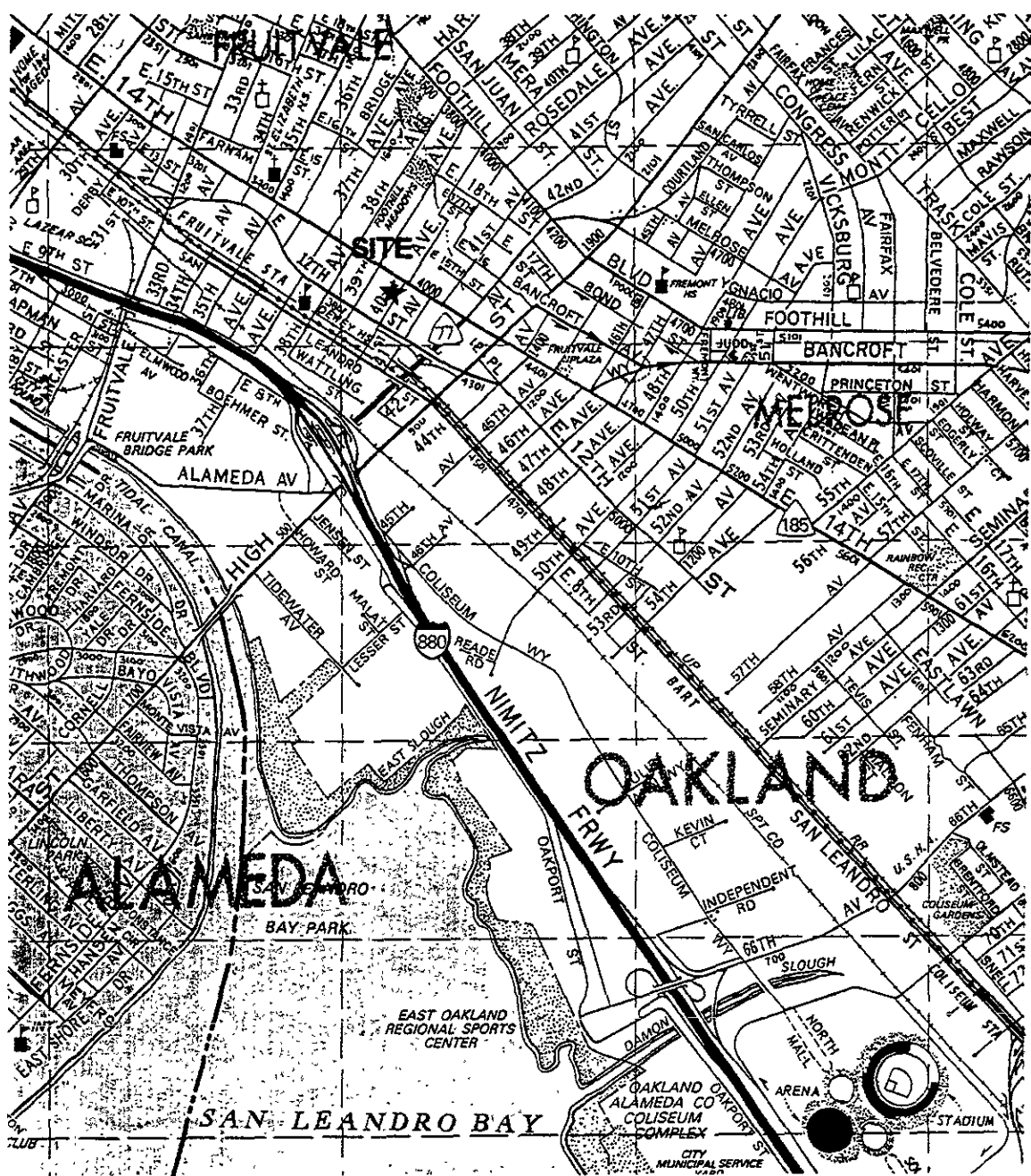

FILE

1. []
 2. []
 3. []
 4. []
 5. []
 6. []
 7. []
 8. []
 9. []
 10. []
 11. []
 12. []
 13. []
 14. []
 15. []
 16. []
 17. []
 18. []
 19. []
 20. []
 21. []
 22. []
 23. []
 24. []
 25. []
 26. []
 27. []
 28. []
 29. []
 30. []
 31. []
 32. []
 33. []
 34. []
 35. []
 36. []
 37. []
 38. []
 39. []
 40. []
 41. []
 42. []
 43. []
 44. []
 45. []
 46. []
 47. []
 48. []
 49. []
 50. []
 51. []
 52. []
 53. []
 54. []
 55. []
 56. []
 57. []
 58. []
 59. []
 60. []
 61. []
 62. []
 63. []
 64. []
 65. []
 66. []
 67. []
 68. []
 69. []
 70. []
 71. []
 72. []
 73. []
 74. []
 75. []
 76. []
 77. []
 78. []
 79. []
 80. []
 81. []
 82. []
 83. []
 84. []
 85. []
 86. []
 87. []
 88. []
 89. []
 90. []
 91. []
 92. []
 93. []
 94. []
 95. []
 96. []
 97. []
 98. []
 99. []
 100. []

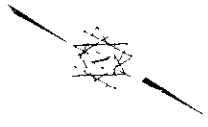
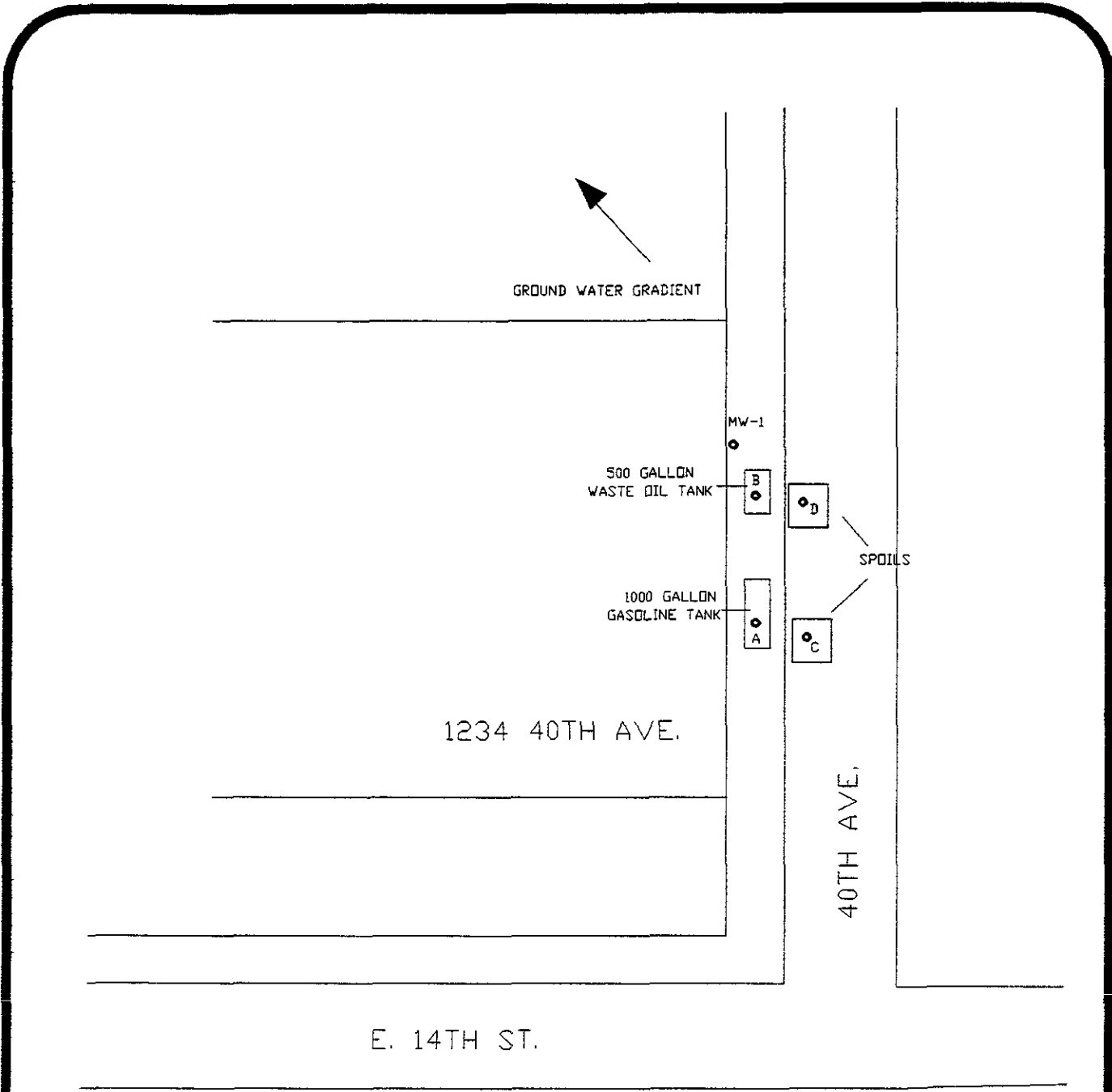

FIGURE 1

SITE LAYOUT MAP
 VERIFIED BY: [illegible]
 DATE: [illegible]

Table 1
SOIL SAMPLING DATA

MAP#	A	B	C	D
LAB#	81681-1	81681-2	81681-3	81681-4
SEMCO SAMPLE #	1 1KG Gasoline	2 500 Waste Oil	3 CSG	4 WO COMP
TPH-G (mg/kg)	1600	570	4	2
Oil/Grease (mg/kg)	-	4000	-	350
TPH-D (mg/kg)	ND	650	10	20
BENZENE (μ g/kg)	3500	ND	ND	ND
TOLUENE (μ g/kg)	5500	470	ND	ND
ETHYL BENZENE (μ g/kg)	43,000	1200	ND	5
XYLENES (μ g/kg)	15,000	8500	6	30
CADMIUM (mg/kg)	-	0.9	-	1.1
CHROM. (mg/kg)	-	62	-	78
LEAD (mg/kg)	-	20	-	90
ZINC (mg/kg)	-	130	-	140
NICKEL (mg/kg)	-	90	-	140

Geology

The site is located on the East Bay Plain about 1.0 mile west of the Oakland Hills, about 1.0 mile east of the San Francisco Bay, and about 0.5 miles north of San Leandro Bay. The property is bounded on the northeast by 14th St.

The site rests on Quaternary Deposits of various physical and compositional properties. The predominant formation is the Temescal Formation consisting of contemporaneous alluvial units of different origin, lithology, and physical properties. The material ranges from irregularly bedded clay, silt, sand and gravel to lenses of clay, silt, sand, and gravel with Claremont Chert.

The Hayward Fault is approximately 1.5 miles East of the site and is an active historic Fault. The Hayward Fault is the only active fault in the Oakland East Quadrangle.

Hydrogeology

The site is located within the East Bay Plain which makes up the ground water reservoir in the area. The water bearing capacity varies within the area due to the juxtaposed positions of the various types of soils and strata encountered underneath the East Bay Plain.

In General the water bearing capacities of the Younger Alluvium range from moderately permeable to low permeable soils. Below the Younger Alluvium at a depth of approximately 70 feet lies the Older Alluvium, which yields large to small quantities of well water.

SITE REMEDIATION

The site remediation work includes; 1) researching the records of monitoring well sites nearby to determine the ground water depth and gradient, 2) evaluation of soil sample data after completion of the re-excavation to determine if a monitoring well is justified, and 3) in the event that a monitoring well is required, installation of the well, along with quarterly monitoring and reporting.

Notifications

The following notifications will take place before beginning work.

1. Work Plan will be submitted to Alameda County Health Agency (ACHA). Drilling permits also will be obtained from ACHA.
2. Work area will be marked with white paint and Underground Service Alert, (800) 227-2600, will be notified at least one week prior to commencement of work.
3. Barney Chan, Alameda County Health Agency, (510) 271-4530, will be notified at least 72 hours prior to commencement of site work.
4. Bill Owens, Motor Partners, (510) 935-3840, will be notified at least 48 hours prior to commencement of site work.

GROUNDWATER STUDIES

Task 1 - Determination of Ground water Depth and Gradient

The records of nearby monitoring wells will be researched to determine the depth to ground water. In addition, the information from these studies will be used to determine the direction of ground water gradient.

Task 2 - Re-excavation Sampling and Evaluation

After completion of the re-excavation and soil sampling required for the two tank sites at 1234 40th Ave., the data will be re-evaluated to determine whether or not a monitoring well is needed.

Task 3 - Well Installation and Development

A monitoring well will be installed if it is required. It will be installed within 10 ft. of the waste oil tank in the down gradient direction. After completion, the well will be monitored for four quarters over the period of one year to determine any impacts on local groundwater quality. The

groundwater monitoring well (MW-1, Figure 2) will be installed and developed according to SWRCB standards following the procedures in Appendix B.

During drilling, soil samples will be collected at 5-ft. intervals or at distinct lithologic changes. In addition, one soil sample will be collected immediately above the water table (from the capillary fringe) in each well. Soil samples will be screened using an OVM. Unless hydrocarbon vapor concentrations greater than approximately 10 ppm are detected, only the soil sample from the capillary fringe will be submitted for laboratory analysis.

Rationale for well location. Because water tables in the East Bay Plain tend to mimic topography, the local groundwater gradient direction is expected to be to the southwest, toward San Leandro Bay. Using this assumption, monitoring well MW-1 will be located in the sidewalk about 5.0 ft. from the 500-gallon waste oil tank excavation.

Well design specifications. Criteria used to determine well design specifications are contained in Appendix C, Well Construction. The filter pack material (No. 2/14 sand) and screen size (0.010 in.) were selected on the assumption of a sandy clay soil. The screened interval and well depth will be determined on the basis of depth to groundwater. A sketch of the well design is shown in Figure 3. The well will be developed no less than 24 hours after completing the grout seal.

Specifications for MW-1 will be as follows:

Total Depth	25.0 ft.
Bore Diameter	10 in.
Casing Diameter	4 in.
Well Seal Type	bentonite pellets
Well Seal Interval	4.0 - 5.0 ft. bgs
Filter Pack Material	No. 2/14 Lonestar sand
Filter Pack Interval	5.0 - 25.0 bgs
Screen Slot Size	0.010 in
Screened Interval	7.0 - 25.0 bgs

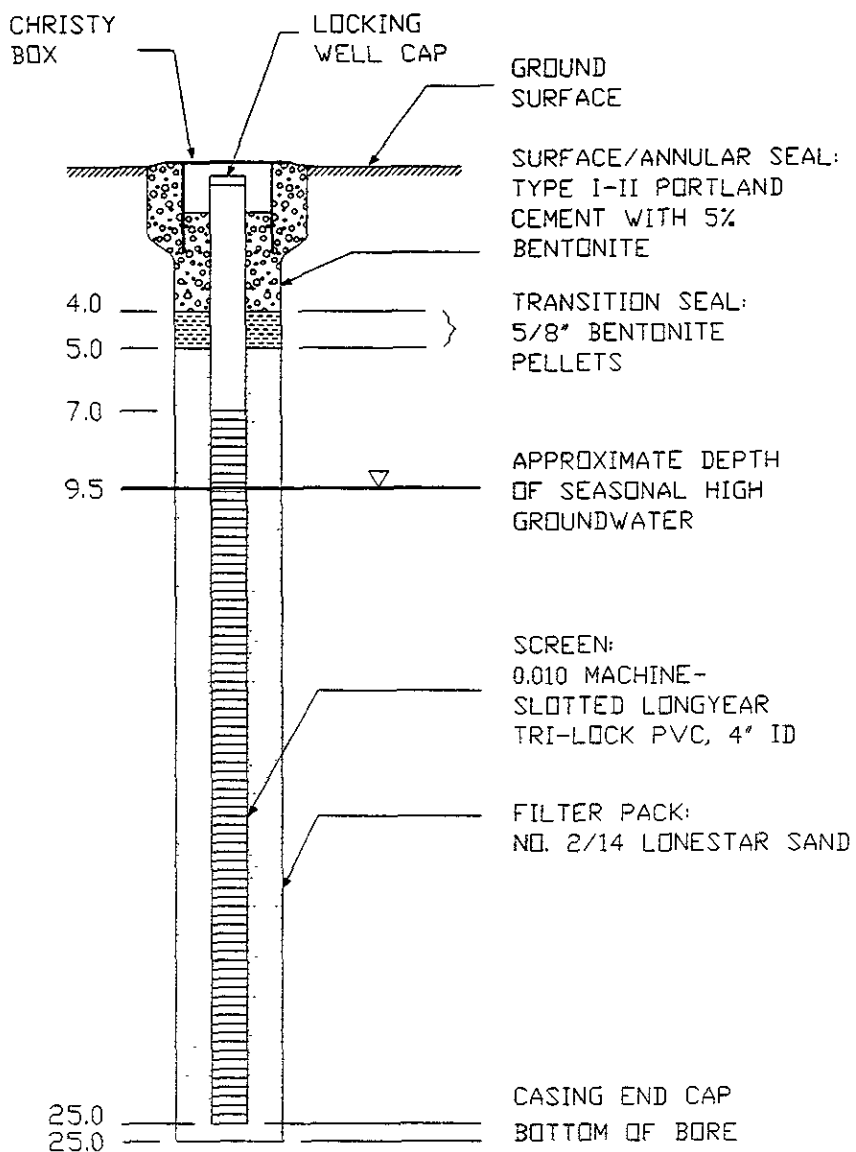

FIGURE 1

MONITORING WELL SPECIFICATIONS
 MOTOR PUMP UNIT
 120V 60Hz 1/2 HP
 1.5" NPT
 1.5" NPT

Task 4 - Quarterly Monitoring

After the well has been completed and purged, initial water samples will be collected and analyzed for TPH-G&D, and BTEX. Samples will be collected, preserved, and analyzed according to protocols in Appendix B.

The well will be sampled quarterly for a period of one year. Water level elevations in MW-1 will be recorded prior to each sampling event. The depth of any floating product will be recorded.

Task 5 - Reporting

A groundwater quality monitoring report will be prepared and submitted each quarter to the Alameda Health Agency, Division of Hazardous Materials, and the RWQCB. The report will include a site history, a summary of all findings, laboratory results, and recommendations for further action.

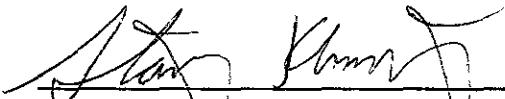
Stanley L. Klemetson, Ph.D., P.E.
Vice President
P.E. No. 40087



JAMES C. BATEMAN PETROLEUM SERVICES, INC.

JAMES C. BATEMAN PETROLEUM SERVICES, INC.

411 W. Hatch Rd Modesto, Calif 95351
 General & Engineering Contractors
 (800) 533-9293
 FAX (209) 524-0503

1741 Leslie St. San Mateo, Calif. 94402
 General & Engineering Contractors
 (415) 572-8033
 FAX (415) 572-9734

CHAIN OF CUSTODY RECORD

PROJECT NAME: MOTOR PARTNERS 40 th OAKLAND						Number of Containers	Analysis Required						REMARKS
SAMPLERS (signature): Joe Ramirez (SEMCO)							TPH-G	TPH-D	BTEX	TOB	CAHC-8240	TPAP	
Station Number	Date	Time	Comp	Grab	Station Location								
#1-1KG	10/12	1:20		✓	#1-1KG-E-10'	1	✓	✓	✓				GASOLINE
#2-500g	10/12	1:30		✓	#2-500-w/o-w-8'	1	✓	✓	✓	✓			WASTE OIL
#3-536	10/12	1:20		✓	#3-1KG Comp.	2	✓	✓	✓				GASOLINE
#4-506	10/12	1:20		✓	#4-500 w/o Comp	2	✓	✓	✓	✓			WASTE OIL
Relinquished by (signature): [Signature]						Date / Time: 11-12-99 11:45		Received by (signature): [Signature]		Date / Time:		Received by (signature):	
Company or Agency: SEMCO								Company or Agency: [Signature]				Company or Agency:	
Relinquished by (signature):						Date / Time:		Received by (signature):		Date / Time:		Received by (signature):	
Company or Agency:								Company or Agency:				Company or Agency:	
Relinquished by (signature):						Date / Time:		Received for Laboratory by (signature):		Date / Time:		Remarks/Shipping Information	
Company or Agency:													

SUPERIOR ANALYTICAL LABORATORIES, INC.

825 ARNOLD, STE. #14 • MARTINEZ, CALIFORNIA 94553 • (415) 229-1512 I S

DOHS #319
DOHS #220

LABORATORY NO.: 81681
CLIENT: SEMCO
CLIENT JOB NO.: 40TH OAKLAND

DATE RECEIVED: 10/12/90
DATE REPORTED: 10/19/90

ANALYSIS FOR BENZENE, TOLUENE, ETHYL BENZENE & XYLENES
by EPA SW-846 Methods 5030 and 8020

LAB #	Sample Identification	Concentration (ug/Kg)			
		Benzene	Toluene	Ethyl Benzene	Xylenes
1	#1-1KG	3500	5500	43000	15000
2	#2-500W/O	ND<150	470	1200	8500
3	#3-CSG	ND<3	ND<3	ND<3	6
4	#4-WOCOMP	ND<3	ND<3	5	30

ug/Kg - parts per billion (ppb)

Method Detection Limit in Soil: 3 ug/Kg

QAQC Summary:

Daily Standard run at 20ug/L: RPD = <15%
MS/MSD Average Recovery = 109 %: Duplicate RPD = 2

Richard Srna, Ph.D.

Richard Srna for
Laboratory Manager

RECEIVED
10-19-90

SUPERIOR ANALYTICAL LABORATORIES, INC.

825 ARNOLD, STE. 114 • MARTINEZ, CALIFORNIA 94553 • (415) 229-1512

DOHS #319
DOHS #220

C E R T I F I C A T E O F A N A L Y S I S

LABORATORY NO.: 81681
CLIENT: SEMCO
CLIENT JOB NO.: 40TH OAKLAND

DATE RECEIVED: 10/12/90
DATE REPORTED: 10/19/90

ANALYSIS FOR TOTAL PETROLEUM HYDROCARBONS
by Modified EPA SW-846 Method 8015

LAB #	Sample Identification	Concentration (mg/Kg) Diesel Range
1	#1-1KG	ND<10
2	#2-500W/O	650
3	#3-CSG	10
4	#4-WOCOMP	20

Method Detection Limit for Gasoline and Diesel in Soil: 10 mg/Kg

QAQC Summary:

Daily Standard run at 200mg/L: RPD Gasoline = 4

RPD Diesel = 6

MS/MSD Average Recovery = 103%: Duplicate RPD = 0

Richard Srna, Ph.D.

Dorena Srna
Laboratory Manager

SUPERIOR ANALYTICAL LABORATORIES, INC.

825 ARNOLD, STE. 114 • MARTINEZ, CALIFORNIA 94553 • (415) 229-1512

DOHS #319
DOHS #220

C E R T I F I C A T E O F A N A L Y S I S

LABORATORY NO.: 81681
CLIENT: SEMCO
CLIENT JOB NO.: 40TH OAKLAND

DATE RECEIVED: 10/12/90
DATE REPORTED: 10/19/90

ANALYSIS FOR TOTAL PETROLEUM HYDROCARBONS
by Modified EPA SW-846 Method 5030 and 8015

LAB #	Sample Identification	Concentration (mg/Kg) Gasoline Range
1	#1-1KG	1600
2	#2-500W/O	570
3	#3-CSG	4
4	#4-WOCOMP	2

mg/kg - parts per million (ppm)

Method Detection Limit for Gasoline in Soil: 1 mg/Kg

QAQC Summary:

Daily Standard run at 2mg/L: RPD Gasoline = 5
MS/MSD Average Recovery = 113%: Duplicate RPD = 2

Richard Srna, Ph.D.

Dorena Srna for
Laboratory Manager

SUPERIOR ANALYTICAL LABORATORIES, INC.

825 ARNOLD, STE. 114 • MARTINEZ, CALIFORNIA 94553 • (415) 229-1512

DOHS #319
DOHS #220

C E R T I F I C A T E O F A N A L Y S I S

LABORATORY NO.: 81681
CLIENT: SEMCO
CLIENT JOB NO.: 40TH OAKLAND

DATE RECEIVED: 10/12/90
DATE REPORTED: 10/19/90

ANALYSIS FOR TOTAL OIL AND GREASE by Method 503E

LAB #	Sample Identification	Concentration(mg/Kg) Oil & Grease
2	#2-500W/O	4000
4	#4-WOCOMP	350

mg/kg - parts per million (ppm)

Method Detection Limit for Oil and Grease in Soil: 20mg/Kg

QAQC Summary: Duplicate RPD : 13

Richard Srna, Ph.D.

Dorana Srna Srna
Laboratory Manager

SUPERIOR ANALYTICAL LABORATORIES, INC.

825 ARNOLD, STE. 114 • MARTINEZ, CALIFORNIA 94553 • (415) 229-1512

DOHS #319
DOHS #220

C E R T I F I C A T E O F A N A L Y S I S

LABORATORY NO.: 81681
CLIENT: SEMCO
CLIENT JOB NO.: 40TH OAKLAND

DATE RECEIVED: 10/12/90
DATE REPORTED: 10/19/90

ANALYSIS FOR CADMIUM, CHROMIUM, LEAD & ZINC
by EPA SW-846 Methods 7130, 7190, 7420, 7950 Respectively

LAB #	Sample Identification	Concentration (mg/Kg)			
		Cadmium	Chromium	Lead	Zinc
2	#2-500W/O	0.9	62	20	130
4	#4-WOCOMP	1.1	78	90	140

mg/kg - parts per million (ppm)

Method Detection Limit for Cadmium in Soil: 0.2 mg/Kg
Method Detection Limit for Chromium in Soil: 2 mg/Kg
Method Detection Limit for Lead in Soil: 10 mg/Kg
Method Detection Limit for Zinc in Soil: 0.2 mg/Kg

QAQC Summary: MS/MSD Average Recovery : 117%
Duplicate RPD : 0

Richard Srna, Ph.D.

Dorena Srna for
Laboratory Manager

SUPERIOR ANALYTICAL LABORATORIES, INC.

825 ARNOLD, STE. 114 • MARTINEZ, CALIFORNIA 94553 • (415) 229-1512

DOHS #319
DOHS #220

C E R T I F I C A T E O F A N A L Y S I S

LABORATORY NO.: 81681
CLIENT: SEMCO
CLIENT JOB NO.: 40TH OAKLAND

DATE RECEIVED: 10/12/90
DATE REPORTED: 10/19/90

ANALYSIS FOR TOTAL NICKEL by SW-846 Method 7520

LAB #	Sample Identification	Concentration (mg/Kg) Total Nickel
2	#2-500W/O	90
4	#4-WOCOMP	140

mg/kg - parts per million (ppm)

Method Detection Limit for Nickel in Soil: 10 mg/Kg

QAQC Summary:

Duplicate RPD : 7

Richard Srna, Ph.D.

Richard Srna
Laboratory Manager

APPENDIX A
Soil Sampling in Excavations

COLLECTION

Representative samples of excavated soils will be obtained for laboratory analysis using a slide hammer. Samples will be contained in 2-in. i. d., 6-in. long brass tubes.

HANDLING

Sample tubes will be sealed at each end with Teflon sheeting and PVC end caps. Samples will be labeled with self-adhesive, preprinted labels indicating project name (or number), sample number, boring/well number, sample depth, date and time, and sampler's name. Samples will be stored in an ice chest with dry ice or blue ice, maintained at 4° C, and transported under chain-of-custody to a State-certified laboratory.

DOCUMENTATION

A sample location sketch will be recorded in the geologist's field notebook. Collection methods, signs of contamination, soil type, preferential flow paths in the excavation, names of regulators and contractors, and any other appropriate information will also be recorded. Copies of field notes will be submitted to the Project Manager.

FIELD EQUIPMENT DECONTAMINATION PROCEDURES

The sampler will be decontaminated after each use by washing in a trisodium phosphate solution, followed by tap water and deionized water rinses. Equipment will be sealed in plastic bags or other sealed containers to prevent contact with solvents, dusts or other contamination.

All rinseate used in the decontamination process will be collected in 5-gallon buckets and either returned to the excavation or stored on site in steel, DOT-approved drums. Drums used to store rinseate will be labeled as to contents, suspected contaminants, date container filled, expected removal date, company name, contact and phone number. Drums will then be sealed and left on-site for subsequent disposal pending analytical results.

QUALITY CONTROL

One field duplicate sample will be collected and analyzed for every sample set up to 10 samples. The field duplicate will be collected identically to and immediately after a randomly chosen sample. This will provide second sample confirmation and a means of determining sample precision.

APPENDIX B

Water Sampling in Wells and Boreholes

GENERAL CONSIDERATIONS

In general, the composition of water within the well casing and in close proximity to the well is not representative of groundwater quality. This may be due to contamination by drilling equipment or to disparities in oxidation-reduction potential between the well and aquifer. To obtain a representative groundwater sample, therefore, the well should be pumped or bailed until the well is thoroughly flushed of standing water and contains fresh water from the aquifer. One common procedure is to pump or bail the well until a minimum of three bore volumes (or alternatively, 10 casing volumes) have been removed.

PURGING

During each round of sampling, static water level will be measured prior to purging using an electronic sounder. All water-level measurements will be recorded to the nearest 0.01 foot with respect to mean sea level elevation.

A minimum of three bore volumes shall be purged from the well prior to sampling. Bore and well volumes will be calculated using the following formula:

$$CV = h [(A_{bore} - A_{casing})(0.3) + A_{casing}]$$

where CV is the bore volume, h is the height of the water column in the well, A_{bore} and A_{casing} are the cross sectional areas of the bore and casing respectively, and 0.3 is the porosity of the filter pack.

To ensure that water in the well has been exchanged, pumping or bailing shall commence at the top and work downward. The well will be allowed to return to 80 percent of the original water level before sampling.

Temperature, pH, specific conductance, and turbidity will be measured for each bore volume pumped. Purging will continue until these field-measured water quality parameters have stabilized and the water is, in the judgement of the geologist, representative of water in the aquifer. Data obtained from field water quality measurements will be recorded in the field log book or data sheets. A separate aliquot of groundwater collected from the purge water outlet stream will be used for field measurements; samples intended for laboratory analysis will not be used.

Temperature, pH, specific conductance, and turbidity meters will be calibrated per manufacturers guidelines. Calibration shall be documented in the field log book or data sheets and will include a description of the calibration method, identification number of equipment and/or reagents used in calibration.

Temperature will be measured with a good grade mercury-filled Centigrade thermometer, bimetallic-element thermometer, or electronic thermistor.

Acidity/alkalinity (pH) will be measured by dipping conductivity probe in the water source or sample; pH will be measured withing a few minutes after collection of the sample.

Conductivity will be measured using a vial of development/purge water and a turbidity meter. The instrument will be calibrated to read between 1 and 400 Nephelometric turbidity units (NTUs). This is a measure of the amount of light scattered at right angles to the path of light passing through the water. The greater the NTU reading, the greater the amount of light scattered by particles in the water, therefore, the greater the turbidity.

SAMPLE COLLECTION

Wells and borings will be sampled using a new, clean, disposable Teflon bailer attached to new, clean string. Sample vials and bottles will be filled to overflowing and sealed so that no air is trapped in the vial or bottle. Once filled, samples will be inverted and tapped to test for air bubbles. Samples will be contained in vials and bottles approved by the US EPA and the RWQCB, San Francisco Bay Region. Some analyses may require separate sample containers in accordance with EPA methods described in 40 CFR, Part 136 and SW-846.

Water samples intended for volatile hydrocarbon analysis will be contained in 40 ml VOA vials prepared according to EPA SW-849 and capped with Teflon-lined septa caps. Samples to be analyzed using EPA Method 602/8020 will contain a small amount of preservative (HCl). Samples to be analyzed using EPA Method 601/8010 and EPA Method 624/8240 will not be preserved. Water samples to be analyzed for low level THH-D will be stored in dark glass, 1-liter bottles to reduce degradation by sunlight. Antimicrobial preservative (HCl) may be added to the sample bottle if a prolonged holding time is expected prior to analysis.

Sample containers will be labelled with self-adhesive, preprinted tags. Labels will contain the following information in waterproof ink:

1. Project number (or name)
2. Sample number (or name)
3. Sample location (well number, etc.)
4. Date and time samples were obtained
5. Treatment (preservative added, filtered, etc.)
6. Name of sample collector

All purged water will be stored on site in steel, DOT-approved drums. Drums will be labeled as to contents, suspected contaminants, date container filled, expected removal date, company name, contact and phone number. Drums will then be sealed and left on-site for subsequent disposal pending analytical results.

DOCUMENTATION

Sampling information will be recorded in ink in a bound notebook with consecutively number pages. Pages may not be removed for any reason. Alternatively, specially formatted field data sheets may be used to record the information collected during water quality sampling. Errata may be marked out with a single line, and initials of person making the change. The log book and data sheets will be placed in the project file when sampling is completed.

FIELD EQUIPMENT DECONTAMINATION PROCEDURES

All sampling equipment, such as buckets and stands, will be decontaminated after each use by washing in a trisodium phosphate solution followed by tap water rinses. Equipment will be stored in plastic bags or other sealed containers to prevent contact with solvents, dusts or other contamination.

All rinseate used in the decontamination process will be stored on site in steel, DOT-approved drums. Drums will be labeled as to contents, suspected contaminants, date container filled, expected removal date, company name, contact and phone number. Drums will then be sealed and left on-site for subsequent disposal pending analytical results.

APPENDIX C
Well Construction

GENERAL PRACTICES

Each monitoring well will be designed to register the potentiometric surface, facilitate soil sampling, and permit water sampling. CEC's standard procedures for well installation and soil/water sampling meet or exceeds guidelines set forth by the EPA, California State Regional Water Quality Control Board, San Francisco Bay Region and the Alameda County Health Agency. Drilling, construction, and completion of all exploratory borings and monitoring wells will be in conformance with procedures in this manual.

DRILLING PROCEDURES

Monitoring wells will be drilled with a hollow-stem, continuous-flight auger. All boring and logging will be overseen by a geologist with special attention given to avoiding the contamination of clean aquifers underlying contaminated zones. The following procedures used by CEC geologists prevent pollution of underlying aquifers:

1. Drilling will cease if 5.0 ft. of saturated impermeable material is encountered. It will be assumed that any significant saturated, impermeable layer, such as a clay layer, is an aquitard separating the shallow and deep aquifers and should not be penetrated.
2. Drilling will be terminated 20 ft. below any perched or unconfined water table.
3. Drilling will be terminated at 50 ft. below ground surface if groundwater is not encountered. This is above nearly all deep aquifers currently supplying groundwater in the Bay Area.

The drill rig operator and the CEC geologist will discuss significant changes in material penetrated by the drill, changes in drilling conditions, hydraulic pressure, and drilling action. The CEC geologist will be present during the drilling of exploratory borings and will observe and record changes in relative moisture, content, lithology, and degree of induration, and will note water producing zones. This record will be used later to prepare a detailed lithologic log. Lithologic descriptions will include soil or rock type, color, grain, size, texture, hardness, degree of induration, carbonate content, presence of fossils and other materials (gypsum, hydrocarbons) and other pertinent information. A copy of the logs will be retained in the field file at the project site.

Soil Cuttings

Soil cuttings generated during drilling will be placed in steel, DOT-approved drums. Drums will be labeled as to contents, suspected contaminants, date container filled, expected removal date, company name, name and phone number of technical contact, and name of generator. Drums will be sealed and left on-site for subsequent disposal pending analytical results. Disposal of soil

cuttings will be the responsibility of the owner/generator, although CEC may arrange for disposal.

Screen and Casing

The monitoring well assembly will consist of new, schedule 40 PVC casing from the bottom of the boring to the ground surface. Casing will be shipped in protective wrappers and carefully rinsed before installation.

From the base of the well to approximately 2.0 ft. feet above the ground water surface, casing will consist of perforated casing (well screen); the remainder of the well will be solid PVC casing. Perforated casing (well screen) will be factory slotted. Screen sizes are not intended to provide optimum flow but to provide hydraulic connection between the borehole and the monitoring well. The perforation size is selected to retain 70 to 90% of the filter pack material.

Upon completion of drilling, well casing will be assembled and lowered to the bottom of the boring. Casing will be connected with dry threads or slip joints, since using glue to connect casing sections could cause false analytical interpretations of water quality. The bottom of the casing will be approximately flush with the bottom of the boring and will be capped with a threaded PVC cap or plug. Using the lithologic log for control, the CEC geologist will specify the exact depths of screened intervals so that the well screen is within the water-bearing zone to be monitored.

Where possible, the casing will extend six inches above the ground surface. When monitoring wells are placed in traffic areas where they cannot extend above the surface, pre-cast concrete or cast iron boxes and covers will be installed.

Filter Pack

After the monitoring well assembly has been lowered to the specified depth, filter pack will be placed in the annular space between the well casing and borehole from the bottom of the well to approximately 2 ft. above the top of the well screen. The depth to the top of the filter pack will be verified using the tremie pipe or a weighted steel tape. Filter pack will be at least 95% silica sand. Sand will be hard, durable, well rounded, spherical grains that have been washed until free of dust and contamination.

ASTM recommends the following guidelines for screen slot and filter pack selection based on the anticipated strata:

Anticipated Soil Type	Recommended Well Screen Slot Size (inches)	Recommended Filter Pack Material (U.S. sieve sizes)
Sand & Gravel	0.030	20 to 4
Silt & Sand	0.020	30 to 8
Clay & Silt	0.010	50 to 16

Reference: 1988, Development methods for water wells: an anthology: NWWA Water Well Journal.

Grout Seal

A layer of bentonite pellets approximately one foot thick will be placed above the filter pack and charged with water. The depth to the top of the bentonite pellets layer will be verified using the tremie pipe or a weighted steel tape.

A cement-bentonite grout mixture will be tremied into the annular space from the bentonite seal to the top of the well. The grout material will be a mixture of Portland Type I/II cement (94 lb.) to five gallons of clean water or a sand-cement slurry with a minimum of 11 sacks of Portland Type I/II cement per cubic yard. Only clean water from a municipal supply shall be used to prepare the grout.

Capping Wells

After emplacing the grout, steel or pre-cast concrete well vault (or valve box) will be completed below ground surface. A metal tag containing well number and construction data will be permanently attached to the well vault. A steel well cover clearly marked "monitoring well" will be bolted to the vault. A suitable watertight, locking well cap will be fitted to the riser casing to prevent the entry of surface runoff or foreign matter.

WELL DEVELOPMENT

When well installation is complete, the well will be developed by surging, and/or bailing, and/or pumping to remove fines from the formation and filter pack. Well development generally restores natural hydraulic properties to the adjacent soils and improves hydraulic properties near the borehole so the water flows more freely in the well. Wells will be developed no less than 24 hours after emplacing the grout seal.

At the least, pumping should continue until water in casing storage has been removed. There are at least two common methods for determining that water in casing storage has been removed and water is flowing freely from the aquifer: (1) Monitor water level while pumping. When the pumping water level has "stabilized," it is likely that little or no water from casing storage is being pumped. (2) Monitor the temperature, pH, conductivity, and turbidity of the water while pumping. When these parameters "stabilize," it is probable that little or no water from casing storage is being pumped and most of the water is coming from the aquifer.

CEC will use the latter method. During development, pH, specific conductance, and temperature of the return water from the water pump will be measured. Well development will proceed until these field-measured water quality parameters have stabilized and the water is, in the judgment of the geologist, at its greatest possible clarity.

Temperature, pH, specific conductance, and turbidity meters shall be calibrated per manufacturers guidelines. Calibration shall be documented in the field log book or data sheets and will include a description of the calibration method, identification number of equipment and/or reagents used in calibration.

Temperature will be measured with a good grade mercury-filled Centigrade thermometer, bimetallic-element thermometer, or electronic thermistor.

pH measurements will be made as soon as possible after collection of the sample preferably within a few minutes.

Conductivity will be measured by dipping the conductivity probe in the water source or sample. The probe must be immersed above the vent. The temperature of the sample will be used to calculate specific conductance from the conductivity measurement. Conductivity will be reported in units of micromhos per centimeter (mmho/cm) at 25° C.

Turbidity will be measured by placing a vial of development/purge water into a turbidity meter for measurement. The instrument will be calibrated to read in a range between 1 and 400 Nephelometric turbidity units (NTUs). This is a measure of the amount of light scattered at right angles to the path of light passing through the water. The greater the NTU reading, the greater the amount of light scattered by particles in the water, therefore, the greater the turbidity.

WELL PURGING AND WATER SAMPLING

Purging and sampling will be in accordance with procedures in Appendix B, Water Sampling in Wells and Boreholes.

SOIL SAMPLING IN BOREHOLES

U.S. Environmental Protection Agency standards serve as the foundation for all field sampling operations performed by CEC. EPA SW-846 is the primary publication from which procedures are derived. While some aspects of field and laboratory work may be delegated to the California Department of Health Services, the California Water Resources Control Board, the San Francisco Regional Water Quality Control Board, and the Alameda County Health Agency establish the general and specific criteria for sampling.

Sample Intervals

Undisturbed soil samples will be obtained for laboratory analysis and geotechnical classification at 5-ft. intervals or at distinct lithologic changes, beginning at 5 ft. below grade. In addition, one soil sample will be collected immediately above the water table (from the capillary fringe) in each hole. If only one hole is bored, it will be logged continuously from five 5 ft. below grade to the bottom of the bore.

Soil samples will be screened using an OVM. In general, samples with hydrocarbon vapor readings over 10 ppm or the appearance or odor of contamination will be submitted for laboratory analysis. Unless hydrocarbon vapors are detected with the OVM, only the soil sample from the capillary fringe will be submitted for laboratory analysis.

Collection Devices

Samples will be collected using a 2- or 2.5-inch-i.d. Modified California split spoon sampler containing three, six-inch-long brass tubes. The sampler and tubes will be decontaminated before and after each use by steam cleaning, or an Alconox solution wash, and tap water followed by deionized water rinses. The sampler will be driven ahead of the augers using a 140 pound drop hammer. The average blow counts required to drive the sampler the last 12 inches will be recorded on the boring logs.

Preservation and Handling

Sample tubes will be labeled, sealed at each end with Teflon sheeting and PVC end caps, placed in ziplock bags, and stored in an ice chest with dry ice. Samples will be delivered under chain of custody to a State-certified laboratory.

Soils Classification

Soils exposed at the ends of each brass tube will be examined by a geologist for obvious signs of contamination and classified according to the Unified Soil Classification System. These observations will be recorded in the boring logs.

Sample Labeling and Chain of Custody

Samples selected for analysis will be labeled with self-adhesive, preprinted labels indicating project name (or number), sample number, boring/well number, sample depth, date and collection time. The same information will be recorded on the chain of custody.

DOCUMENTATION

A well construction diagram for each monitoring well will be completed by the geologist and submitted to the project manager when the work has been completed. In addition, the details of well installation, construction, development, and field measurements of water quality parameters will be summarized as daily entries in a field notebook or data sheets which will be submitted to the project manager when the work has been completed.

DRILLING EQUIPMENT DECONTAMINATION PROCEDURES

The sampler will be decontaminated before and after each use by steam cleaning or washing in an Alconox solution, followed by tap water and deionized water rinses. Only clean water from a municipal supply will be used for decontamination of drilling equipment. Equipment will be sealed in plastic bags or other sealed containers to prevent contact with solvents, dusts or other contamination.

All rinseate used in the decontamination process will be stored on site in steel DOT approved drums. Drums will be labeled as to contents, suspected contaminants, date container filled, expected removal date, company name, contact and phone number, sealed and left on-site for subsequent disposal pending analytical results.

Unified Soil Classification System

Compiled by B. W. Pipken, University of Southern California

MAJOR DIVISIONS			GROUP SYMBOLS	TYPICAL NAMES
COURSE-GRAINED SOILS More than half of material is larger than no. 200 sieve size	GRAVELS More than half of coarse fraction is larger than no. 4 sieve size	Clean gravels	GW	Well-graded gravels, gravel-sand mixtures, little or no fines.
			GP	Poorly graded gravels, gravel-sand mixtures, little or no fines.
		Gravel with fines	GM	Silty gravel, gravel-sand-silt mixtures.
			GC	Clayey gravels, gravel-sand-clay mixtures.
	SANDS More than half of coarse fraction is smaller than no. 4 sieve size	Clean sands	SW	Well-graded sands, gravelly sands, little or no fines.
			SP	Poorly graded sands, gravelly sands, little or no fines.
		Sands with fines	SM	Silty sands, sand-silt mixtures.
			SC	Clayey sands, sand-clay mixtures.
FINE-GRAINED SOILS More than half of material is smaller than no. 200 sieve size	SILTS AND CLAYS	Low liquid limit	ML	Inorganic silts and very fine sands, rock flour, silty or clayey fine sands, or clayey silts, with slight plasticity.
			CL	Inorganic clays of low to medium plasticity, gravelly clays, sandy clays, silty clays, lean clays.
			OL	Organic silts and organic silty clays of low plasticity.
	SILTS AND CLAYS	High liquid limit	MH	Inorganic silts, micaceous or diatomaceous fine sandy or silty soils, elastic silts.
			CH	Inorganic clays of high plasticity, fat clay.
			OH	Organic clays of medium to high plasticity, organic silts.
			Highly organic soils	



FIGURE 1

UNIFIED SOIL CLASSIFICATION SYSTEM
 (REVISED 1972)
 U.S. DEPARTMENT OF AGRICULTURE
 AGRICULTURAL RESEARCH SERVICE

APPENDIX D

**Site Specific Health and Safety Plan
for Motor Partners**

I. PROJECT PLAN

Objectives and Project Description

Certified Environmental Consulting, Inc., (CEC) has prepared this Health and Safety Plan for Motor Partners prior to installing monitoring wells at the 1234 40th Ave., Oakland, California site. The following emergency response plan will be implemented prior to beginning site work to handle on-site emergencies. The first priority in all emergency incidents will be to minimize adverse health risks to workers.

Field Activities

Site work will include installing one monitoring well to 10 feet below ground water surface, if ground water depth is less than 60 ft.

Personnel Requirements

Field geologist, engineer, and well drillers

Key Personnel and Owner Representative

Project Assignment	Name/Agency	Telephone
Field Geologist	Jim Robbins, CEC	(707) 745-0171
Project Manager, Site Safety Officer	Dr. Gary Rogers, CEC	(415) 341-7630
Principal Investigator	Dr. Stanley L. Klemetson, P.E., CEC	(707) 745-0171
Safety Officer	Michael T. Noble, CIH, CEC	(510) 867-0322
Owner Representative	Bill Owens, Motor Partners	(510) 935-3840

II. JOB HAZARD ANALYSES

Threshold Limit Values for Anticipated Chemical Substances

Substance	OSHA PEL	ACGIH TVL	NIOSH REL
Benzene	10 ppm	10 ppm	0.1 ppm

Toxicological Hazards of Wastes

Human exposure to benzene concentrations in excess of 150 ppm may cause headache, weariness, and loss of appetite. Vapors at high concentrations may cause smarting of the eyes and dermatitis. Benzene appears to be poorly absorbed through skin.

Physical Hazards Associated with Site Activities

- Slip, trip and fall hazards
- Hazards due to falling or swinging objects and heavy equipment
- Excessive noise

III. SITE CHARACTERIZATION

A. Site Information

Location	Motor Partners 1234 40th Avenue Oakland, CA 94621
Topography	Flat and gently sloping to the east
Accessibility	There are no access problems.
Pathways for Hazardous Substance Dispersion	Gasoline may volatalize slightly from soil
Anticipated Weather Conditions	Mild weather
Past and Present Use of Site	Previously auto repair; Now vacant buildings

B. Description of Wastes On Site

Location	Soils underlying sidewalk and building.
Physical State of Wastes	Adsorbed in soil matrix
Range of Concentrations Found to Date	Soil samples below the 1000-gallon tank contained 1600 mg/Kg TPH-G. Soils below the 500-gallon tank contained 570 mg/Kg TPH-G.

IV. PERSONAL PROTECTIVE EQUIPMENT

Level of Protection	Level D
Respiratory Protection	Half mask dual cartridge respirator with organic vapor cartridges; will only be required if airborne concentrations are above action levels.
Protective Clothing	<ul style="list-style-type: none">● Hard hat (required)● Work boots (required)● Safety Glasses (optional)● Hearing Protection (optional)● Protective gloves (optional)
Action Levels and Work Requirements	Don respirators if organics in the breathing zone exceed a constant 20 ppm

V. EXPOSURE MONITORING PLAN

Frequency and Type of Monitoring	Air should be monitored every 30 minutes using an organic vapor meter while excavating and sampling in contaminated areas.
Methodology	Monitor downwind in the breathing zone.

VI. DECONTAMINATION PROCEDURES

For PPE	Leave the work area and remove clothing, respirator last. All non-reusable clothing will be disposed of in garbage containers.
----------------	--

VII. PROTECTION OF GENERAL PUBLIC

Procedures	<p>The contractor will redirect pedestrian traffic around the work area using temporary fencing, or barricades and warning ribbon. The temporary pedestrian walkway will also be protected from automobile traffic using barricades and warning ribbon. Any excavation left open over night will be enclosed with fencing.</p> <p>Only authorized personnel will be permitted within 10 ft. of heavy equipment.</p>
-------------------	---

VII. EMERGENCY RESPONSE

Command and Control

The on-site CEC representative will be responsible for health and safety issues related to sampling and well drilling.

Directions to Hospital

See area map for route to Booth Memorial Hospital, Oakland

Emergency Procedures for Personnel Injured or Exposed in the Work Zone

1. Assist the injured or exposed worker out of the sampling area.
2. Call for medical help.
3. Administer CPR/first aid as needed.
4. If possible, carefully remove the victim's PPE and begin decontamination procedures.

Emergency Agencies with Telephone Numbers

Emergency Service	Name/Agency	Telephone
Ambulance	Oakland Fire Dept.	911
Hospital	Booth Memorial 2794 Garden St. Oakland, CA	(510) 535-5088
Police	Oakland	911
Fire Department	Oakland	911
Public Health	Barney Chan Department of Environmental Health	(510) 271-4530
Emergency Spills	CalEPA	(415) 974-8131
Worker Health and Safety	OSHA	(800) 648-1003
CHEMTREC	CHEMTREC	(800) 424-9300
Utilities	Underground Service Alert	(800) 227-2600

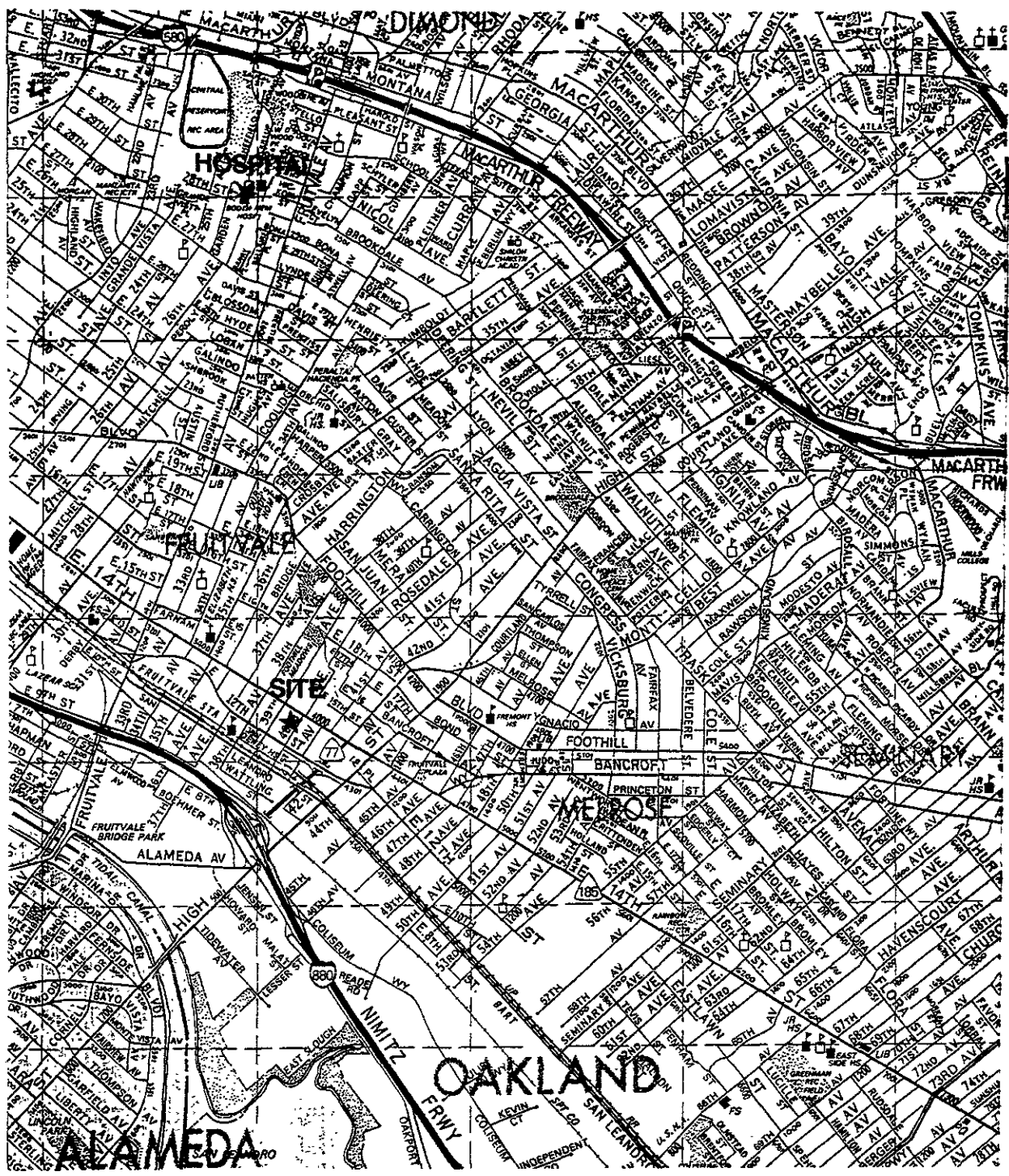



FIGURE 3

DEVELOPMENT

PROPOSED