



PORT OF OAKLAND

RECEIVED

By Alameda County Environmental Health at 3:35 pm, Feb 13, 2014

Mr. Keith Nowell, P.G., C.H.G.
Hazardous Materials Specialist
Alameda County Health Care Services Agency
1131 Harbor Bay Parkway, Suite 250
Alameda, CA 94502-6577

Subject:

Response to ACEH Information Request
Port of Oakland's Harbor Facility Complex
651 Maritime Street
Oakland, California
Alameda County Fuel Leak Case No. RO0000010

Dear Mr. Nowell:

Please find enclosed our response to comments sent to the Port of Oakland (Port) by Alameda County Environmental Health (ACEH) in your e-mail dated December 19, 2013 concerning potential data gaps at the above referenced site. The responses were prepared by ARCADIS, US, Inc (ARCADIS) whom the Port has retained for environmental consulting.

I declare, under penalty of perjury, that the information and/or recommendations contained in the attached report prepared by ARCADIS are true and correct to the best of my knowledge. Please note that the report is stamped by a Professional Geologist in the state of California.

Sincerely,

Jeffrey R. Jones
Supervisor
Environmental Programs and Planning

Jeffrey L. Rubin, CPSS, REPA
Port Associate Environmental Scientist
Environmental Programs and Planning

Mr. Keith Nowell
Hazardous Materials Specialist
Alameda County Health Care Services Agency
1131 Harbor Bay Parkway, Suite 250
Alameda, CA 94502-6577

ENVIRONMENTAL

Subject:
Response to ACEH Information Request
Port of Oakland's Harbor Facility Complex
651 Maritime Street
Oakland, California
Alameda County Fuel Leak Case No. RO0000010

Date:
January 31, 2014

Dear Mr. Nowell:

Contact:
Kathy Brandt

On October 7, 2013 the Port of Oakland (Port) submitted a Request for Closure for the Harbor Facility Complex (HFC) site located at 651 Maritime Street, Oakland, California. Alameda County Environmental Health department (ACEH) requested a meeting with the Port and ARCADIS, Inc. (ARCADIS) to discuss the closure request. The meeting was held on December 19, 2013. During the meeting, ACEH indicated they thought there were data gaps that needed to be investigated prior to granting Site closure. This letter summarizes the data gaps described by the ACEH, provides responses based on available data on Geotracker and in historical hard copy files, and highlights any potential data gaps that could not be addressed with available information. ACEH data gaps are in bold with the subsequent findings listed below:

Phone:
510-596-9675

Email:
Katherine.Brandt@arcadis-us.com

Our ref:
04656020.HFC1

1. Timeline addressing building demolition (including lead and asbestos survey findings), fill placement (fill source and analytical data), on-site building construction, and proposed off-site redevelopment;

- In March 1991, one 10,000-gallon diesel underground storage tank (UST) was removed from the site (NESCO, 1991);
- In July 1992, a total of 8 USTs were removed from the site (RAMCON, 1992);
- In September 1993, a total of 4 USTs were removed from the site (Uribe, 1994);
- In January and September 1998 asbestos and lead-based paint surveys were conducted by ACC Environmental Consultants and Benchmark Environmental, respectively (SCA, 2002);

- In April 2002, an asbestos and lead-based paint survey was conducted on buildings C-401, C-406, and C-407. A total of 157 samples were collected (SCA, 2002);
- From October to December 2002, asbestos and lead-based paint abatement was conducted by Sterling Environmental in accordance with local and federal standards. Impacted materials were disposed of offsite (SCA, 2003);
- Buildings C-406 and C-407 were demolished in 2003 (SCA, 2003; Port of Oakland, 2002);
- Based on "Specification for Demolition of Buildings C401 and C412" (Port of Oakland, 2005) demo began in late 2005 and grading began in early 2006."
- Site re-grading activities were completed under the scope of the Construction of Phase 3B Container Terminal Yard Improvements, Maritime Support Center (Port of Oakland, 2006a). Engineered fill material consisted of crushed concrete and asphalt from the site and from elsewhere at the Port of Oakland. A recent phone conversation with Joseph Trapp, the resident engineer with the Port of Oakland who oversaw the re-grading activities, indicated that the fill material specifically came from Berth 30 at the Port of Oakland. Specifications for the Construction of Phase 3B Container Terminal Yard Improvements, Maritime Support Center, indicates that engineered fill must consist of a soil/rock mixture free of organic matter contamination and that rock fragments will not be larger than three inches in greatest dimension and that not more than 15 percent shall be large than 1-inch in greatest dimension;
- Refer to Attachment 1 for grade elevation changes. Based on the elevation changes provided and an assumption that fill was placed uniformly across the 2225 7th street portion of the site in accordance with the elevation changes shown in Attachment 1, ARCADIS estimates a total volume of approximately 90,000 cubic yards of fill was placed on the 2225 7th street portion of the site (Port of Oakland, 2006a);
- Based on the pre- and post-grading elevation contour lines provided in the grading plans for the 2277 7th street portion of the site in Attachment 1, ARCADIS developed a cross section for the placement of fill and assumed that fill was placed relatively uniformly across the site in order to estimate approximately 20,000 cubic yards of fill was placed on the 2277 7th street portion of the site (Port of Oakland, 2003); and,
- During the second half of 2006 site paving was completed (Port of Oakland, 2006b).
- Because the fill was ground pavement from Port property laboratory analytical testing for environmental parameters was not conducted on the material.

Potential Remaining Data Gaps

- Information pertaining to the exact volume of fill material placed on the site.

2. Documentation of the soil-gas vapor intrusion system including methane sensor installation and system performance (if applicable);

- Methane has been monitored on an annual basis since 2006 using a portable flame ionization detector (FID). From 2009 to present methane has not been detected inside the site buildings. Methane data from 2006 to 2008 could not be located.
- Refer to Attachment 2 which includes as-built drawings from the system installation (Treadwell and Rollo, 2005) and Attachment 3 which includes annual system monitoring results from 2009 to 2013.
- Due to the passive nature of the system, system performance is assessed by confirming air flow within the system. As shown in Attachment 3, this is conducted by checking the sample ports for the presence of air flow and by visually confirming the rotation of the system turbines installed on the roof. System performance is checked during methane monitoring and to date there have been no issues.

Potential Remaining Data Gaps

- Annual methane monitoring results from 2006 to 2008.

3. A list of monitoring and remediation wells and former wells at the Site. Include well construction details, well status, and a well screen evaluation;

- Refer to Attachment 4 for well construction details. The attachment also indicates the screen interval elevation above mean sea level (amsl).
- Refer to Attachment 5 for a compilation of all available boring logs
- In 2006, re-grading activities were completed onsite. Monitoring wells MW-1 through MW-5, and MW-8A and remediation wells RW-1 through RW-9 were brought to grade by adding approximately 0.5 to 3 feet of blank PVC casing.

Potential Remaining Data Gaps

- Top of casing (TOC) elevation data for RW-1 through RW-9 prior to site re-grading activities is not available; and,
- Boring log for monitoring well MW-6.

4. A narrative of well identification nomenclature as the duplicate well identification numbers from the adjoining Port of Oakland (RO000010) and Port of Oakland/ Nation Ways Transport (RO000187) were combined into one case file;

- As indicated in Attachment 4, duplicate wells MW-1, MW-2, and MW-3 originally located at 2225 7th street were installed in 1992 and destroyed in 2002. Duplicate wells MW-1, MW-2, MW-3 on 2277 7th Street were installed 1994 and are part of the current groundwater monitoring program. These are the only three existing wells with duplicate identities. Data presented in the semiannual groundwater monitoring reports from 1994 to 1996 include wells MW-1, MW-2, and MW-3 from 2225 7th street and wells MW-1, MW-2, and MW-3 from 2277 7th street. Data presented in the semiannual groundwater monitoring reports since May 1996 is only from wells MW-1, MW-2, and MW-3 associated with 2277 7th Street.

Potential Remaining Data Gaps

- No data gaps remain

5. A cumulative table presenting groundwater monitoring data, including depth-to-water, laboratory analysis, presence/absence of free product, and well screen submergence;

- Refer to Attachment 6 for historical free product thickness and well screen submergence data;
- Refer to Attachment 7 for historical groundwater analytical results. Limited analytical results are available for monitoring wells MW-1 and MW-3 (located at 2225 7th street) due to the persistent presence of free product (wells are not sampled if free product is observed); and,
- Refer to Attachment 8 for a copy of all free product thickness observations at the site from April 2004 to July 2013. Free product is typically observed in monitoring wells MW-1 and MW-3 (located at 2225 7th street) and remediation wells RW-3, RW-4, RW-6, RW-7, RW-8, and RW-9 at thicknesses typically ranging from 0.1 feet to 3 feet but also as thick as 5 feet.

Potential Remaining Data Gaps

- Without TOC elevation data for RW-1 through RW-9 prior to re-grading activities in 2006, ARCADIS cannot calculate the screen elevation in order to determine the frequency of screen interval submergence.

6. An analysis of the varying groundwater flow directions reported at the Site and a rose diagram;

- Refer to Attachment 9 which provides the site specific groundwater flow direction observed during the second and fourth quarter of each year from 1994 to 2013 with the following exceptions: second quarter 1995, second quarter 2000, and fourth quarter 2002. These data were omitted because the quarterly groundwater monitoring reports are not available.
- Predominant groundwater flow direction is to the north/northeast.

Potential Remaining Data Gaps

- Rose Diagram – Based on review of numerous groundwater monitoring reports it was determined there was a dominant flow direction and a rose diagram was not generated.

7. A summary of the history of free product removal at the Site, including cumulative product removal tables;

- Free product removal data is provided in Attachment 8. From April 29, 2004 to June 7, 2011 a free product removal system which consisted of 6 skimmer pumps in 9 recovery wells and 500-gallon above ground storage Convault, was operated onsite. From December 2004 to July 2007 approximately 178 gallons of product were removed. Between January 2007 and June 2011, free product was removed from MW-3 using a peristaltic pump and polyethylene tubing as part of the weekly system O&M activities. In July 2007 the system was upgraded to include a blower to apply a low vacuum in order to improve product recovery. From August 2007 to June 2011 approximately 1,298 gallons of product were removed. In total, approximately 1,746 gallons of product have been removed by the free product recovery system. The system was shutdown on June 7, 2011 in accordance with the site Feasibility Study/ Corrective Action Plan.

Potential Remaining Data Gaps

- No data gaps remain

8. An assessment of dissolved metals concentrations

- Analytical data for dissolved metals in groundwater could not be found, other than for organic lead.

Potential Remaining Data Gaps

- Dissolved metals concentrations in groundwater currently unknown (other than for organic lead).

9. Verification of the adequacy of Risk Assessment against current standards (including model version and inputs and outputs);

- Although the methods used to estimate excess lifetime cancer risks (ELCRs) due to potential onsite commercial worker inhalation of volatile COPCs have changed since IRIS Consultants conducted the Human Health Risk Assessment (HHRA) in 2003 for the Port of Oakland and estimated ELCRs are likely higher (but still within the acceptable 1E-6 to 1E-4 ELCR target range), there are several factors which would offset newly derived ELCRs. First, soil vapor data were collected

approximately eleven years ago. Since that time, soil vapor concentrations of volatile COPCs have very likely decreased given natural attenuation and the fact that there is not a continuing source. Second, when the site was graded and redeveloped, fill material was brought in; yielding an increased separation distance from residual subsurface impacts of approximately 2.5 feet (based on calculations described in Item 1). Thus, predicted indoor air concentrations of volatile COPCs are expected to be lower than those estimated without additional fill material. Third, the site is entirely paved with asphalt/concrete and a vapor barrier with an effective passive soil gas removal system (as described, above) was installed beneath the onsite building; resulting further decreased likelihood of vapor migration into the building.

Potential Remaining Data Gaps

- No data gaps remain

10. Sub-slab and vent soil gas data (if available);

- Refer to Attachment 10 for historical site-wide soil gas data. A total of 23 soil gas samples were collected during phase II site assessment activities in 2002 (prior to re-grading activities in 2006) and were analyzed for fix gases and gasoline (IRIS/Cambria, 2002). Additional sub-slab and vent soil gas sampling data could not be found.

Potential Remaining Data Gaps

- Sub-slab soil gas data.
- Vent soil gas data following site redevelopment activities

11. Figures using an aerial photograph base showing boring and well locations and an overlay with former building, current buildings, and former tank locations;

- Refer to Attachment 11 for an aerial figure showing current and historical site features.

Potential Remaining Data Gaps

- No data gaps remain

If you have any questions or concerns regarding the information presented in this letter, please contact Katherine Brandt at 510.596.9675 or Katherine.Brandt@arcadis-us.com.

Sincerely,
ARCADIS U.S., Inc.

Katherine Brandt



Kathy Brandt, PG
Project Manager

Attachments:

- Attachment 1 April 2006 site grading plans
- Attachment 2 Soil gas mitigation system as-built drawings
- Attachment 3 Soil gas mitigation system annual monitoring data
- Attachment 4 Well construction details
- Attachment 5 All available boring logs
- Attachment 6 Free product thickness and screen submergence data
- Attachment 7 Groundwater analytical results
- Attachment 8 All available free product thickness data
- Attachment 9 Historical groundwater flow direction figure
- Attachment 10 Historical soil gas analytical results
- Attachment 11 Aerial figure with current and historical site features

References:

- IRIS/Cambria, 2002. Phase II Environmental Site Assessment, Future Port Field Support Services Complex, 2225 and 2277 7th street, Port of Oakland, Oakland, California, June.
- NESCO, 1991. Tank Removal/Closure Report, ANR Freight System, 2225 Seventh Street. Oakland, California, May.
- Port of Oakland, 2002. Conformed Project Manual for Demolition of Buildings C-401, C-406, and C-407, Vision 2000, Oakland, California, June.
- Port of Oakland, 2003. Conformed Project Manual for Construction of Port Field Support Services Complex Building D-510, Maritime Area, Oakland, California, January.
- Port of Oakland, 2005. Specifications for Demolition of Buildings C-401 and D-412 Maritime Support Center, September.

Port of Oakland, 2006a. Specifications for Construction of Phase 3B Container Terminal Yard Improvements, Maritime Support Center, Oakland, California, April.

Port of Oakland, 2006b. Contract Project Manual for Paving a 21-acre Container Yard Within the Maritime Support Center Area, Oakland, California, April.

RAMCON, 1992. Tank Removal Work Summary, Dongary Investment- Truck Maintenance Facility, 2225 Seventh Street, Oakland, California, September.

SCA Environmental Inc., 2002. Summary Report: Bulk Asbestos and Lead-Based Paint Survey Buildings C-401, C-406, and C-407, 2225 and 2277 7th street @ Middle Harbor Road, Oakland, California, April.

SCA Environmental Inc., 2003. Final Report: Asbestos and Lead Hazard Abatement Activities and Methane and VOC Monitoring, Port of Oakland Buildings C-401, C-406, and C-407, Oakland, California, February.

Treadwell & Rollo, 2005. Soil Gas Mitigation System Operation and Maintenance Manual, Harbor Facilities Center, Maritime and Seventh Streets, Port of Oakland, Oakland, California, July.

Uribe and Associates, 1994. Report of Underground Storage Tank Removals, Port of Oakland Building C-401, 2277 7th street, Oakland, February.

Attachment 1

April 2006 site grading plans

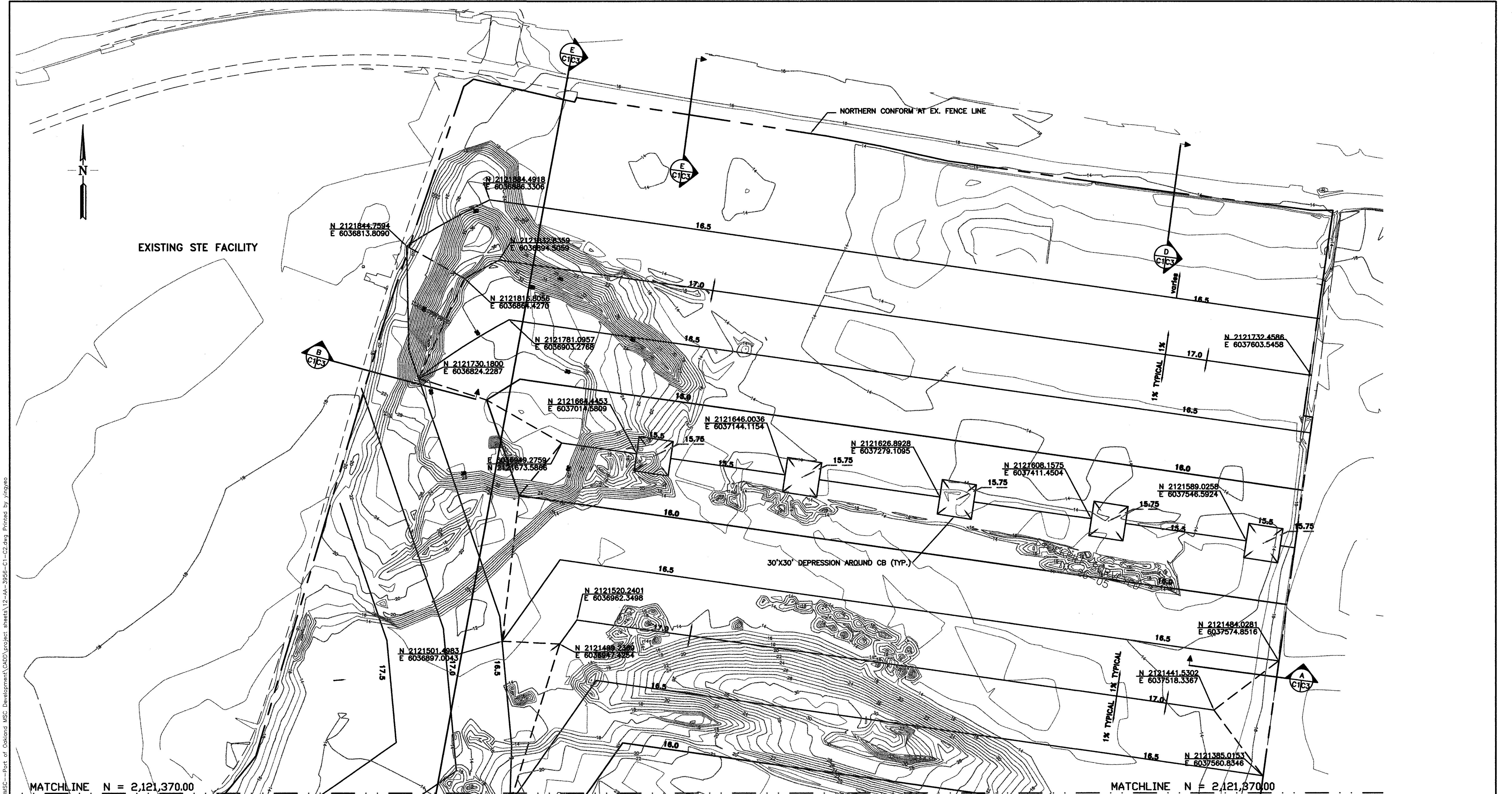

NOTES:
 1. SITE SURVEY COMPLETED OCTOBER 26 AND 27, 2005.

CAUTION: THIS PLAN MAY BE REDUCED ORIGINAL SCALE

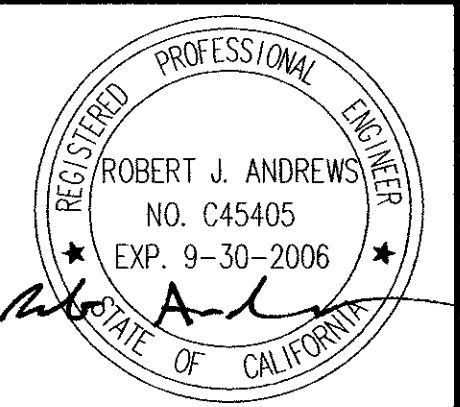

W.O.# 104879
 REFERENCES:
 PLANS
 FIELD BOOKS
 "PORT OF OAKLAND DATUM"
 IS 3.20' BELOW N.G.V.D. '29
 CAUTION:
 CHECK TRACING FOR LATEST REVISIONS

NO.	REVISIONS	DATE	REV'D	APP'D

DRAWN _____ STAFF
 DESIGNED _____
 CHECKED _____

REG. ENGINEER NO. _____
 REG. ENGINEER NO. _____

PORT OF OAKLAND
 530 WATER ST. OAKLAND, CALIFORNIA

MARITIME SUPPORT CENTER
 CONSTRUCTION OF PHASE 3B CONTAINER
 TERMINAL YARD IMPROVEMENTS
 GRADING PLAN SHEET 1 OF 2

DATE: 3-24-06
 SCALE: 1" = 40'
 SHEET: 12 OF 56 SHEETS
 C1 AA-3956

PRINT DATE: 04-10-06 13:52:37 P:\Active Projects\DKM\SC-Port of Oakland MSC Development\CADD\Project sheets\12-AA-3956-C1-C2.dwg Printed by yinyue

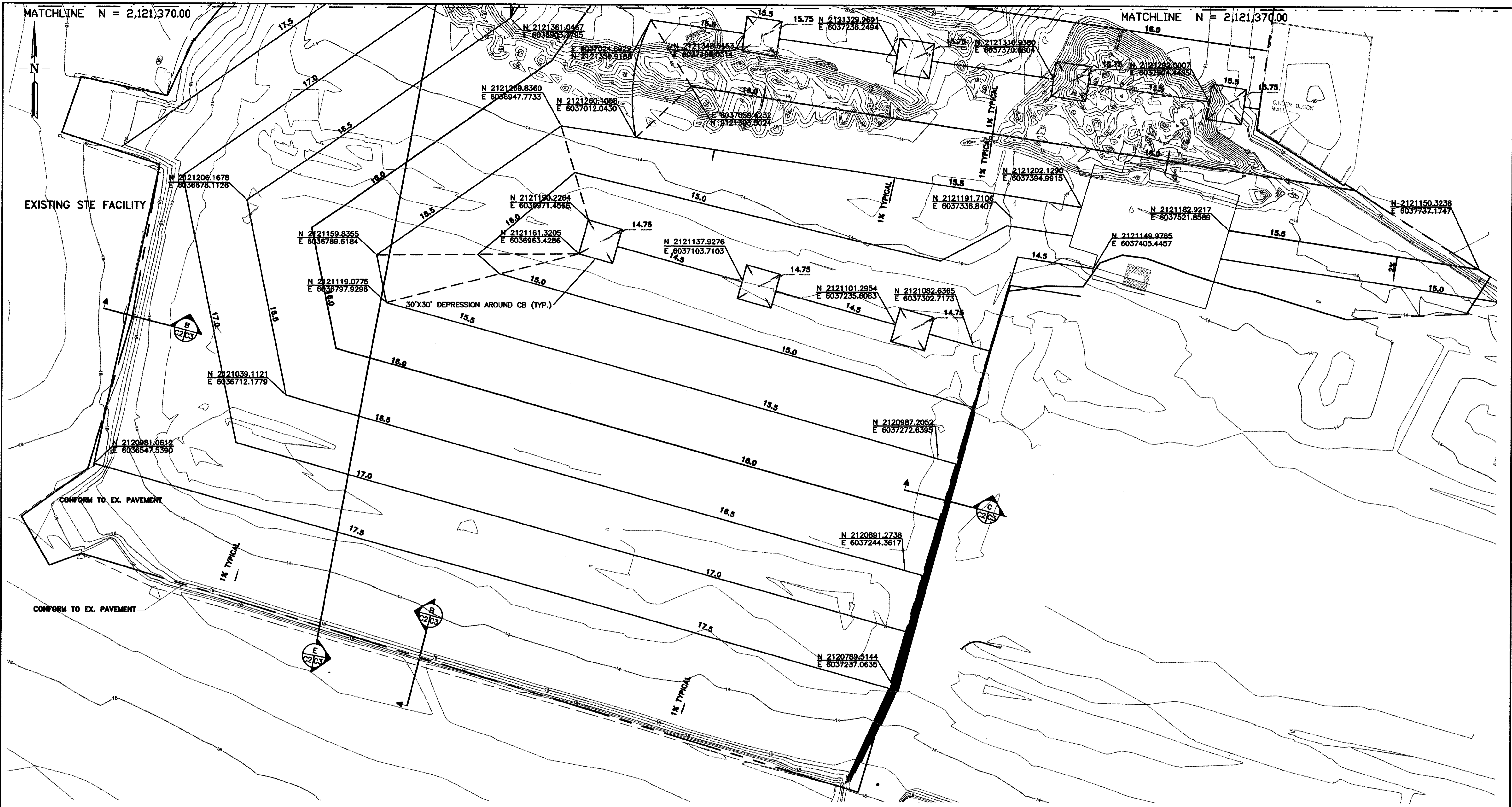

NOTES:
 1. SITE SURVEY COMPLETED OCTOBER 26 AND 27, 2005.

W.O.# 104879

REFERENCES:
 PLANS
 FIELD BOOKS
 "PORT OF OAKLAND DATUM"
 IS 3.20' BELOW N.G.V.D. '29
 CAUTION:
 CHECK TRACING FOR LATEST REVISIONS

NO.	REVISIONS	DATE	REV'D	APP'D

DRAWN _____ STAFF
 DESIGNED _____
 CHECKED _____
 REG. ENGINEER NO. _____
 REG. ENGINEER NO. _____

CAUTION: THIS PLAN MAY BE REDUCED

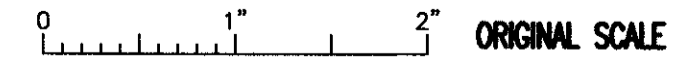

PORT OF OAKLAND
 530 WATER ST. OAKLAND, CALIFORNIA

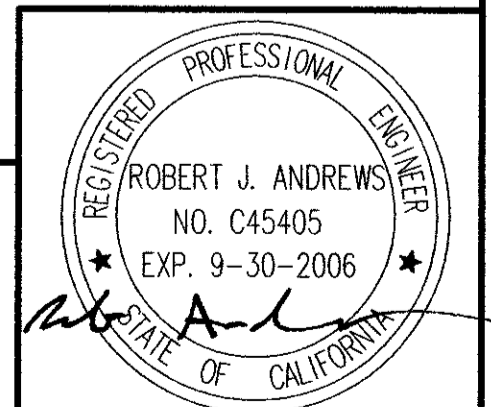

MARITIME SUPPORT FACILITIES
 CONSTRUCTION OF PHASE 3B CONTAINER
 TERMINAL YARD IMPROVMENTS
 GRADING PLAN SHEET 2 OF 2

DATE: 3-24-06
 SCALE: 1" = 40'
 SHEET: 13 OF 56 SHEETS
 C2 AA-3956

PRINT DATE: 04-10-08 13:52:33 P:\Active Projects\DNM\SC-Port of Oakland MSC Development\CADD\project sheets\12-AK-3956-C1-C2.dwg Printed by yingyee

NOTES:

1. REMOVE SURFACE VEGETATION, DELETERIOUS MATERIALS AND ORGANIC-LADEN SOIL TO 6" MIN. BELOW EXISTING GRADE.
2. REMOVE EXISTING ASPHALT PAVEMENT AND PORTLAND CEMENT CONCRETE SLABS AND PAVEMENT. MOISTURE-CONDITION AND COMPACT TOP 6" OF SUBGRADE TO 95% RELATIVE COMPACTION PER ASTM D1557-78.
3. PLACE ENGINEERED FILL AS DESCRIBED IN THE SPECIFICATIONS.
4. PLACE 13" PORT-SUPPLIED AGGREGATE BASE FROM ON SITE STOCKPILE. COMPACT TO 98% RELATIVE COMPACTION PER ASTM D1557-78.
5. UTILIZE ON SITE SOIL FOR ENGINEERED FILL. APPROXIMATE LOCATION AS SHOWN ON SHEET D1.
6. ASPHALT PAVEMENT (BY OTHERS) TO BE PLACED UNDER SEPARATE CONTRACT (PHASE 3C) FOLLOWING GRADING WORK TO BE COMPLETED UNDER THIS CONTRACT.
7. CONTRACTOR TO COORDINATE WITH PHASE 3C PAVING CONTRACTOR.

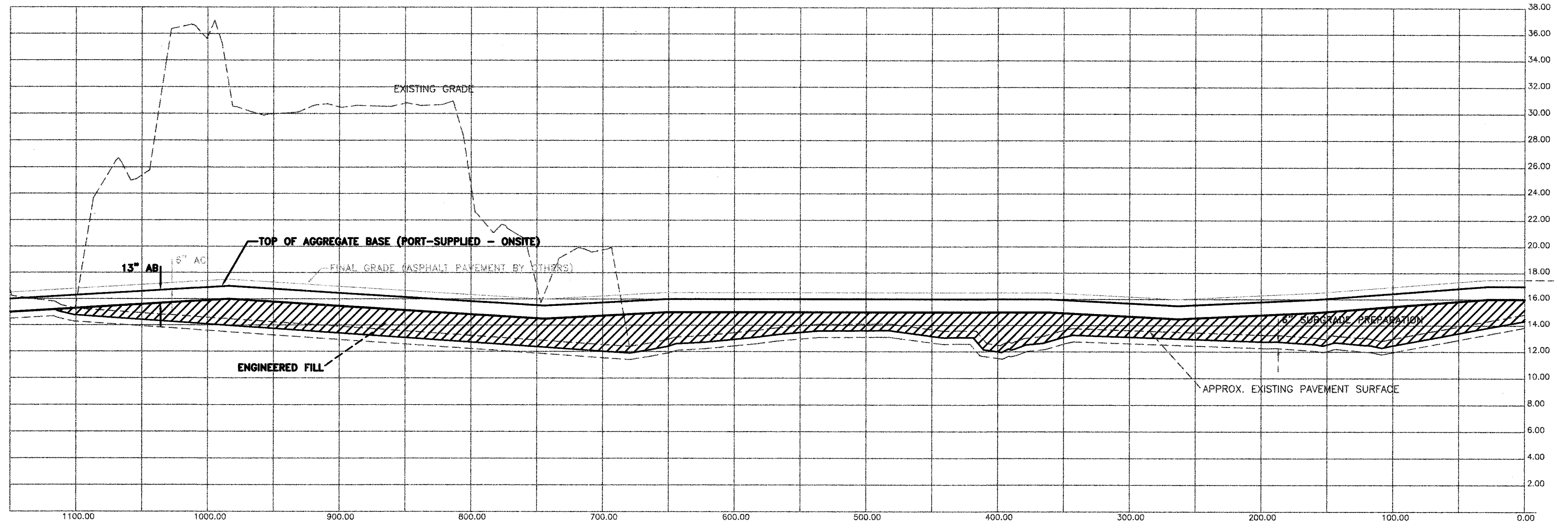

TYPICAL YARD GRADING SECTION
 SCALE: 1"=50'H; 1"=5'V

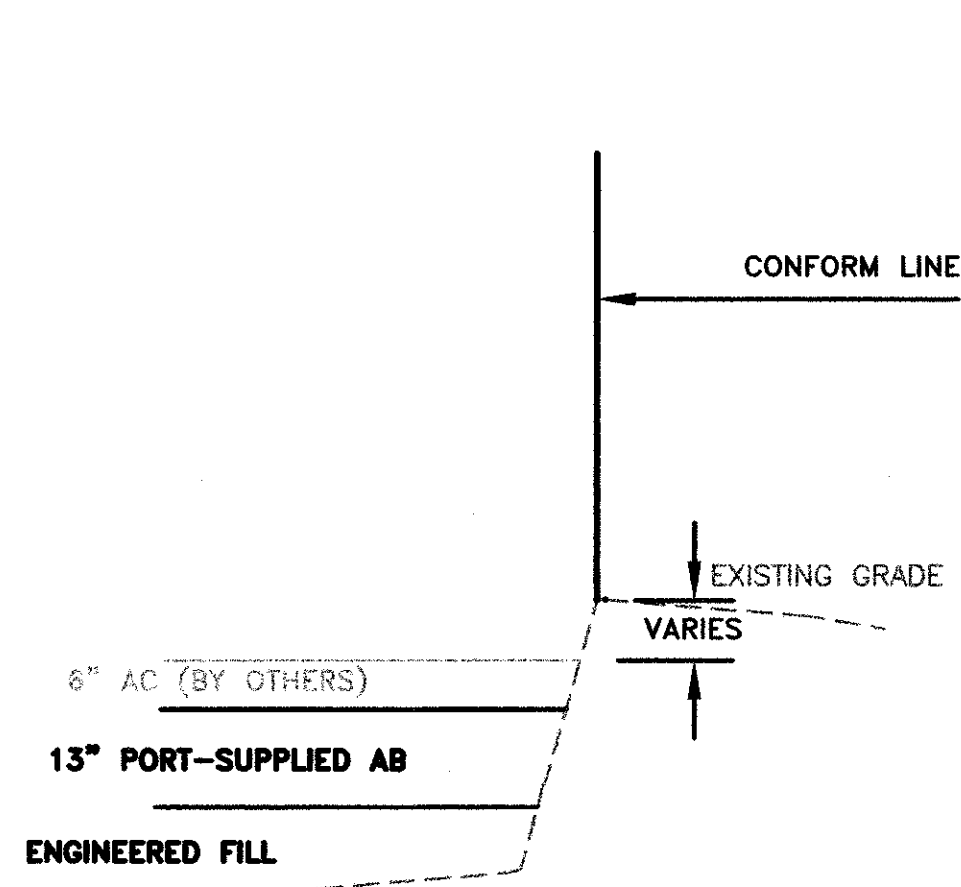

A
 TYPICAL EDGE SECTION
 NTS

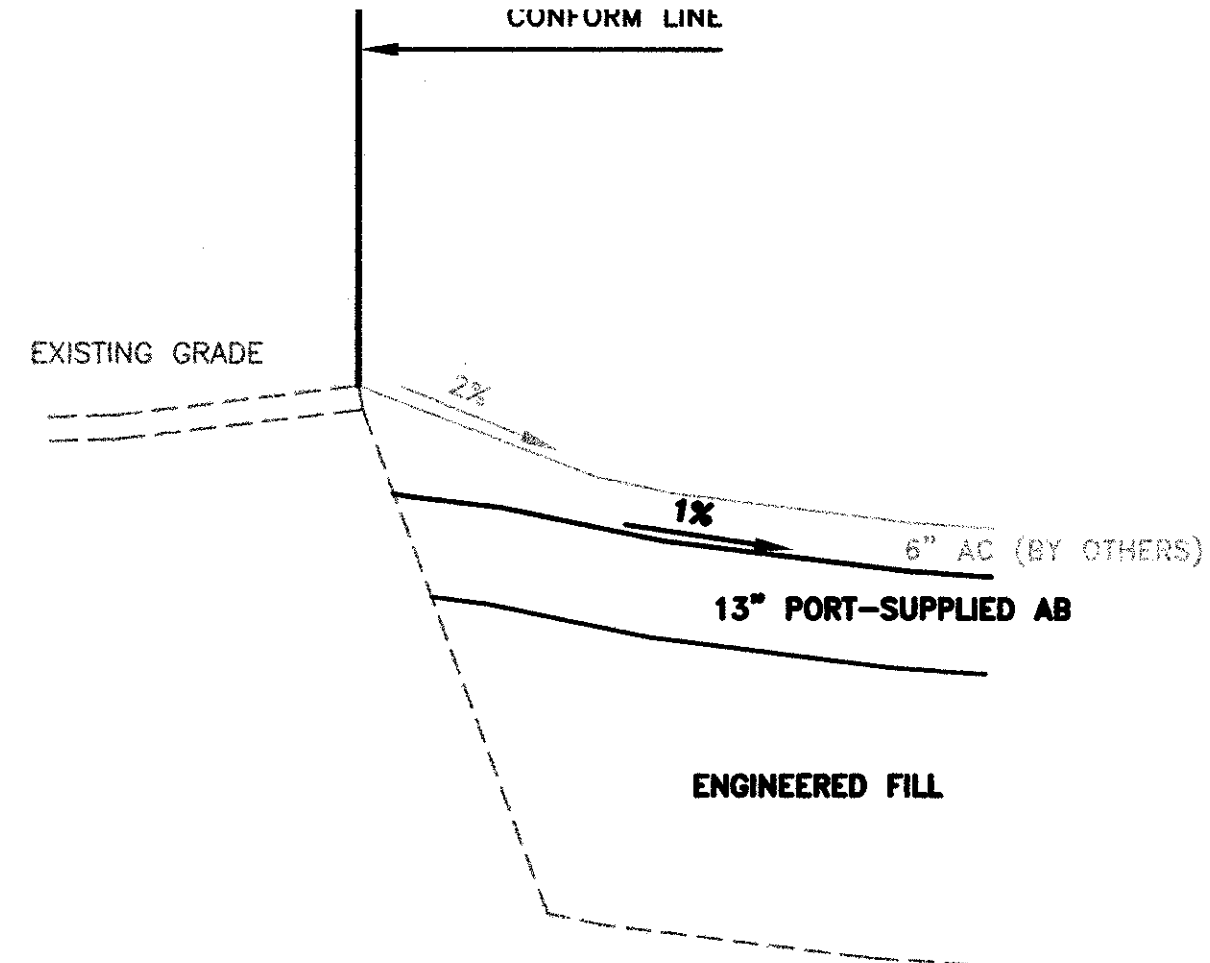

B
 TYPICAL EDGE SECTION
 NTS

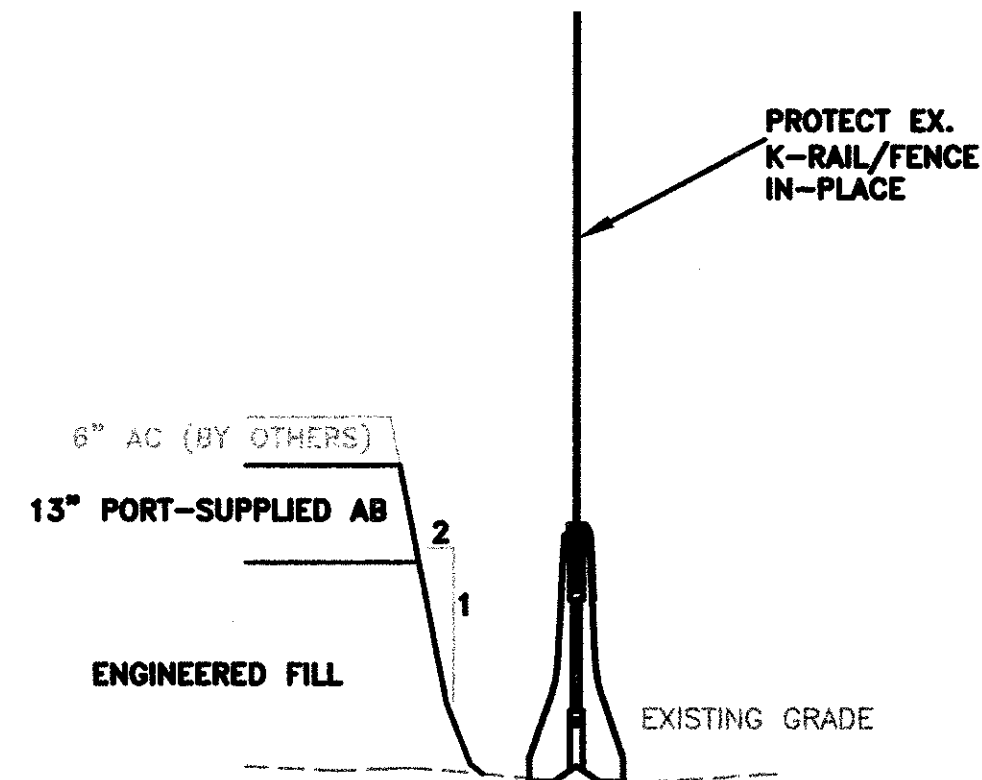

C
 TYPICAL EAST-SOUTH
 EDGE SECTION
 NTS

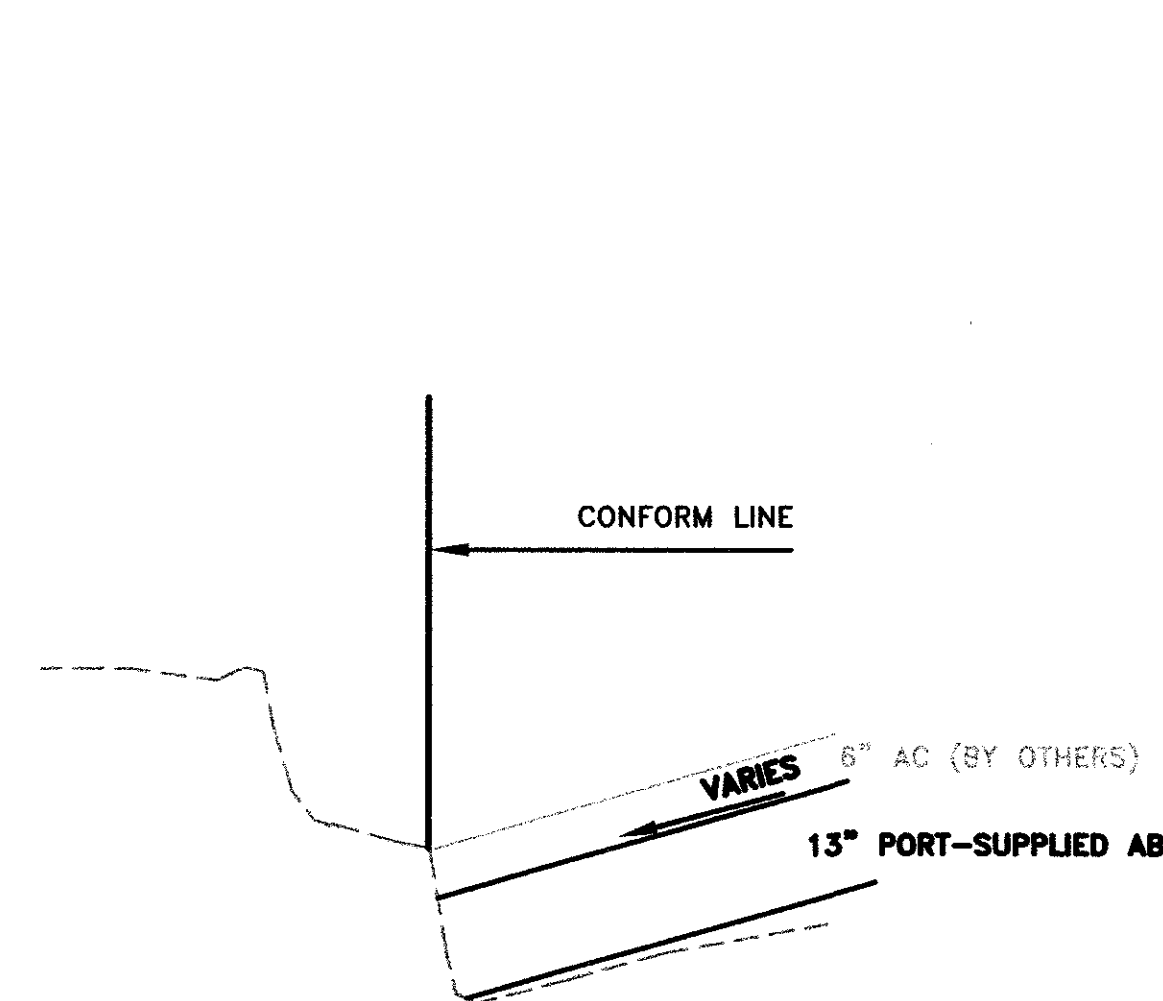

D
 TYPICAL NORTHEAST
 EDGE SECTION
 NTS

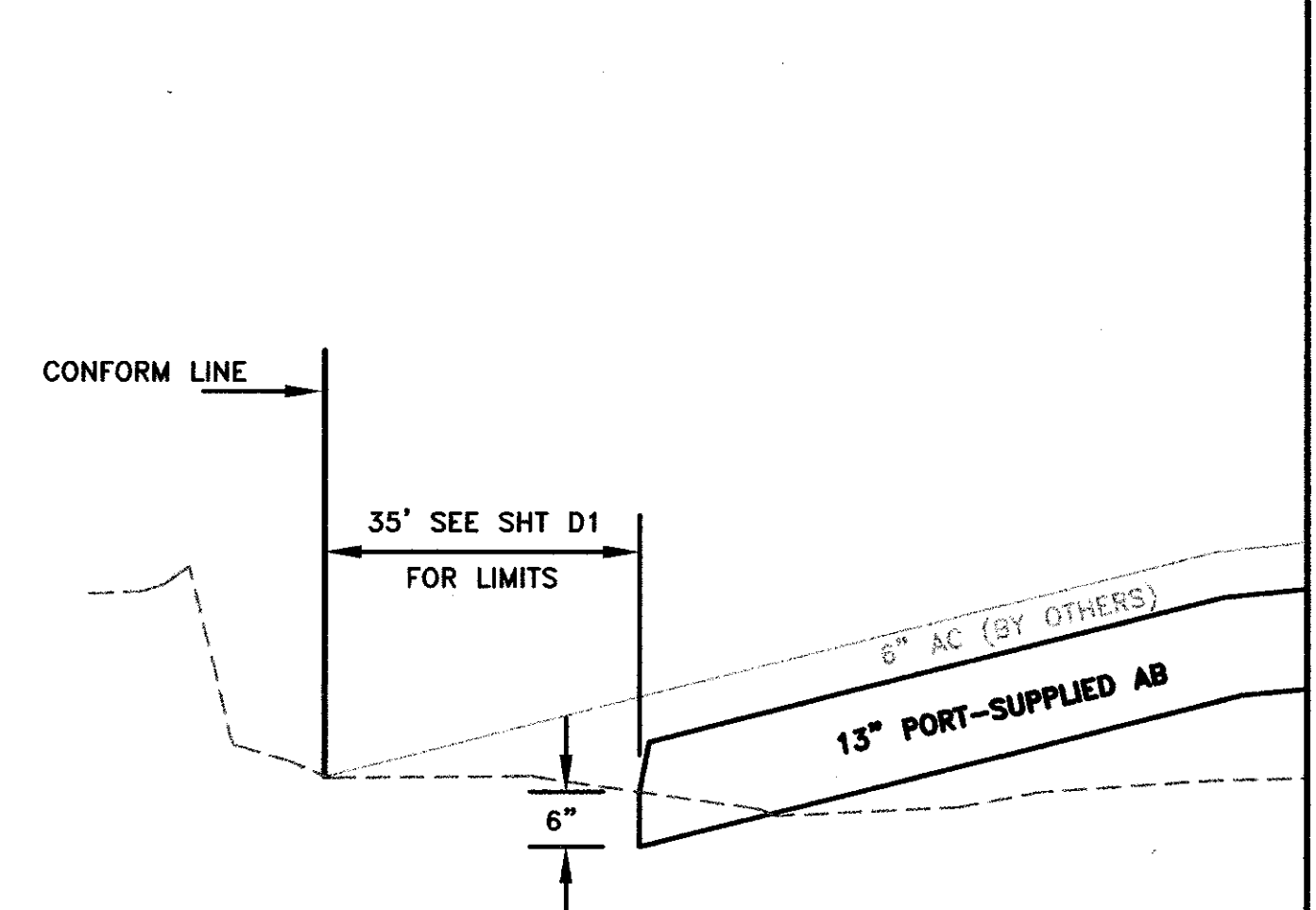

E
 TYPICAL NORTHWEST
 EDGE SECTION
 NTS

W.O.# 104879

REFERENCES:
 PLANS
 FIELD BOOKS
 "PORT OF OAKLAND DATUM"
 IS 3.20' BELOW N.G.V.D. '29
 CAUTION:
 CHECK TRACING FOR LATEST REVISIONS

NO.	REVISIONS	DATE	REV'D	APP'D

DRAWN _____ STAFF
 DESIGNED _____ REG. ENGINEER NO.
 CHECKED _____ REG. ENGINEER NO.

CAUTION: THIS PLAN MAY BE REDUCED



PORT OF OAKLAND

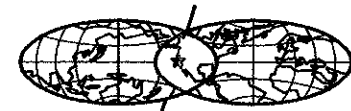

530 WATER ST. OAKLAND, CALIFORNIA

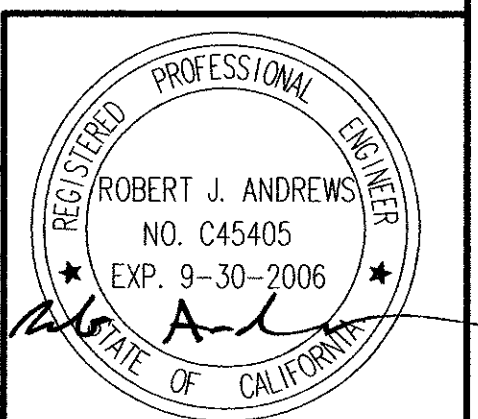

MARITIME SUPPORT CENTER

CONSTRUCTION OF PHASE 3B CONTAINER
 TERMINAL YARD IMPROVMENTS

GRADING AND PAVING TYPICAL DETAILS

DATE: 3-24-06

SCALE: AS SHOWN

SHEET: 14 OF 56 SHEETS

C3 AA-3956

1354805 P:\Active Projects\DMSC-Port of Oakland MSC Development\CADD\project sheets\14-AA-3956-C3.dwg Printed by jmgro



SUBJECT: Port of Oakland
HFL grading change 2003?
JOB NO:

BY: DATE:
CHKD: DATE:

PAGE

SHEET
/

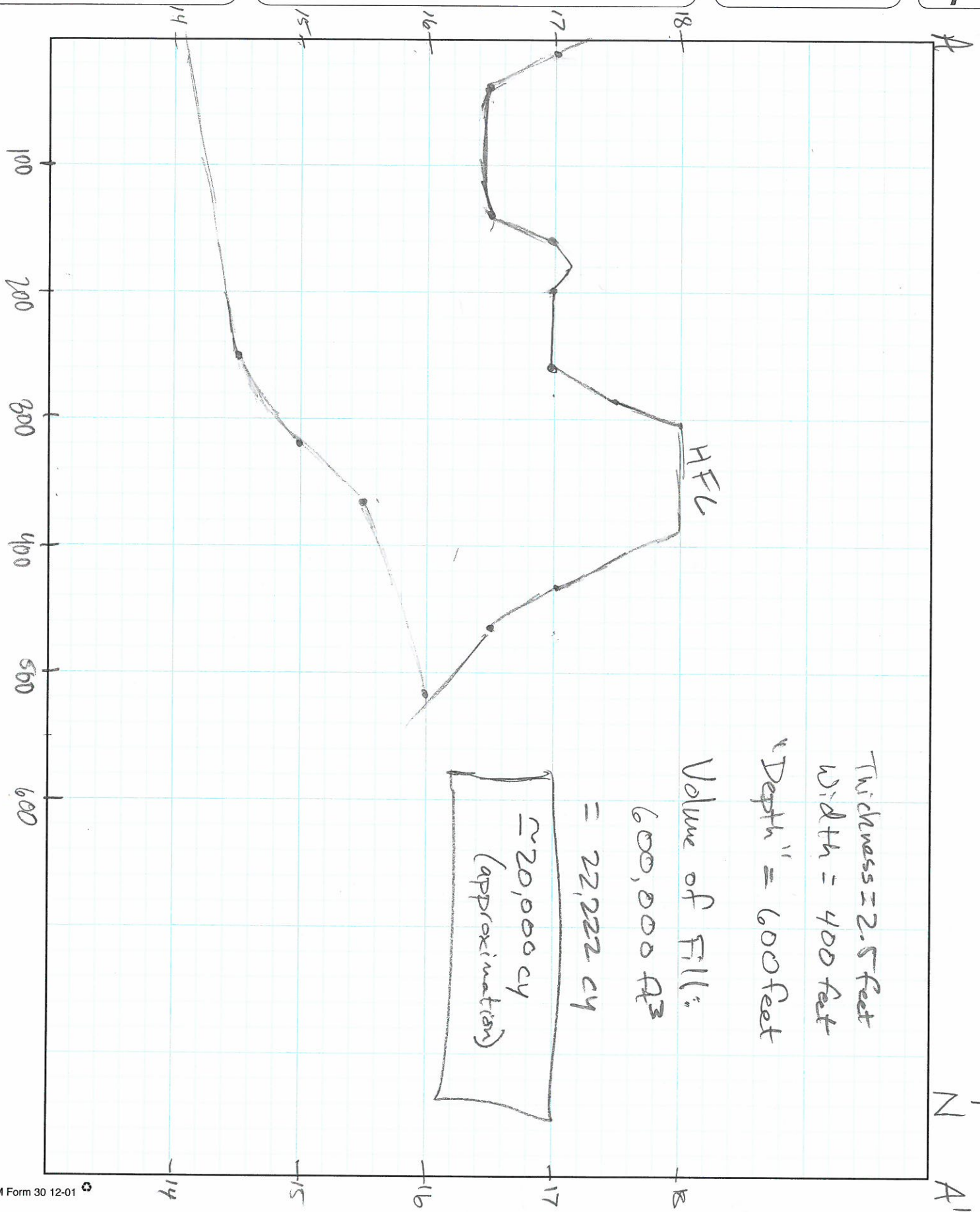



NOTE:
FOR NOTES SEE C3.01.

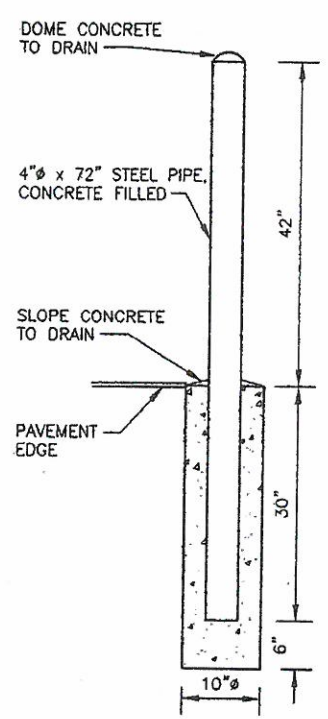
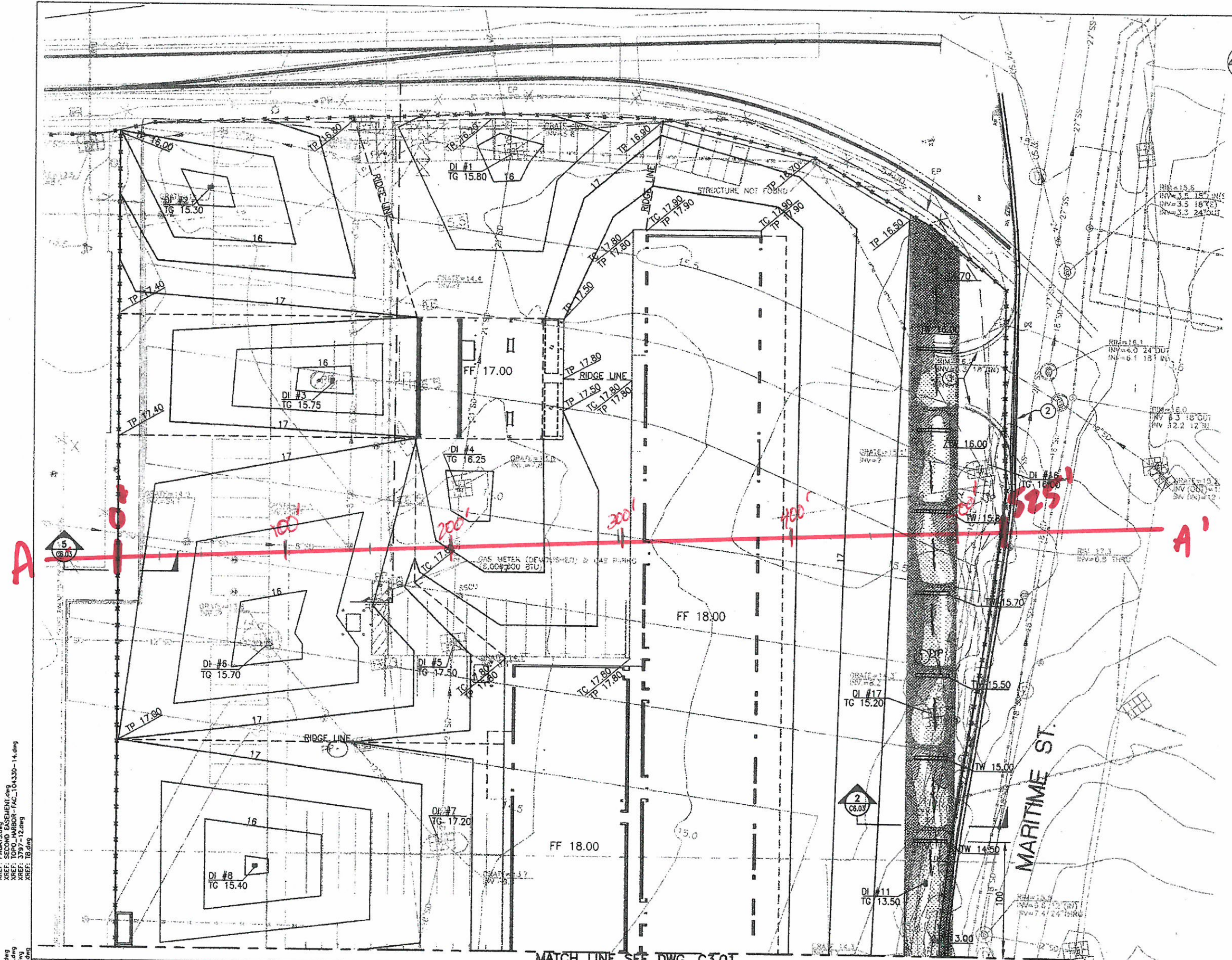

BIO-SWALE PROTECTION BOLLAR
NTS

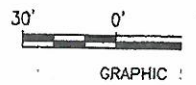

FILE: J:\DRAWINGS\2K1008\VC-GRADE.dwg 01/31/03 at 12:11
XREF: A101.dwg
XREF: FMBAS.dwg
XREF: SECOND EASEMENT.dwg
XREF: C:\GIS\DATA\PORT-PAC_10\330-14.dwg
XREF: TSMALL.dwg
XREF: 3797-12.dwg
XREF: MAINL.DWG

REFERENCES:
PLANS AA
FIELD BOOKS
"PORT OF OAKLAND DATUM"
IS 3.20' BELOW MEAN SEA LEVEL.
CAUTION:
CHECK TRACING FOR LATEST REVISIONS

NO.	REVISIONS	DATE	APP'D

REVIEWED _____ FACILITIES DEPARTMENT
 REVIEWED _____ CONSTRUCTION DEPARTMENT
 REVIEWED _____ PROJECT PLANNING DEPARTMENT

DRAWN M. KYAW
 DESIGNED E. SLINTAK C039925
 CHECKED R.T. WONG REG. ENGINEER NO. C020107
 REVIEWED M. KOSINSKI C57384 REG. ENGINEER NO. _____

PORT OF OAKLAND
 530 WATER ST. OAKLAND, CALIFORNIA

CHIEF ENGINEER
 APPROVED _____
 RECOMMENDED _____
 REG. ENGINEER NO. C 23297
 REG. ENGINEER NO. C 33213
 REG. ENGINEER NO. C 43841

Michael Wills Architects
 471 Ninth Street
 Oakland, CA 94607
 tel: (510) 287-9710

AGS, Inc.
 Consulting Engineers
 364-14th Street, 5th FL.
 Oakland, CA 94612
 Tel: (510) 251-1180
 Fax: (510) 251-1190

MARITIME & 7TH STREET SITE
 PORT FIELD SUPPORT SERVICES COMPLEX
 GRADING PLAN

MATCH LINE SEE DWG. C3.02

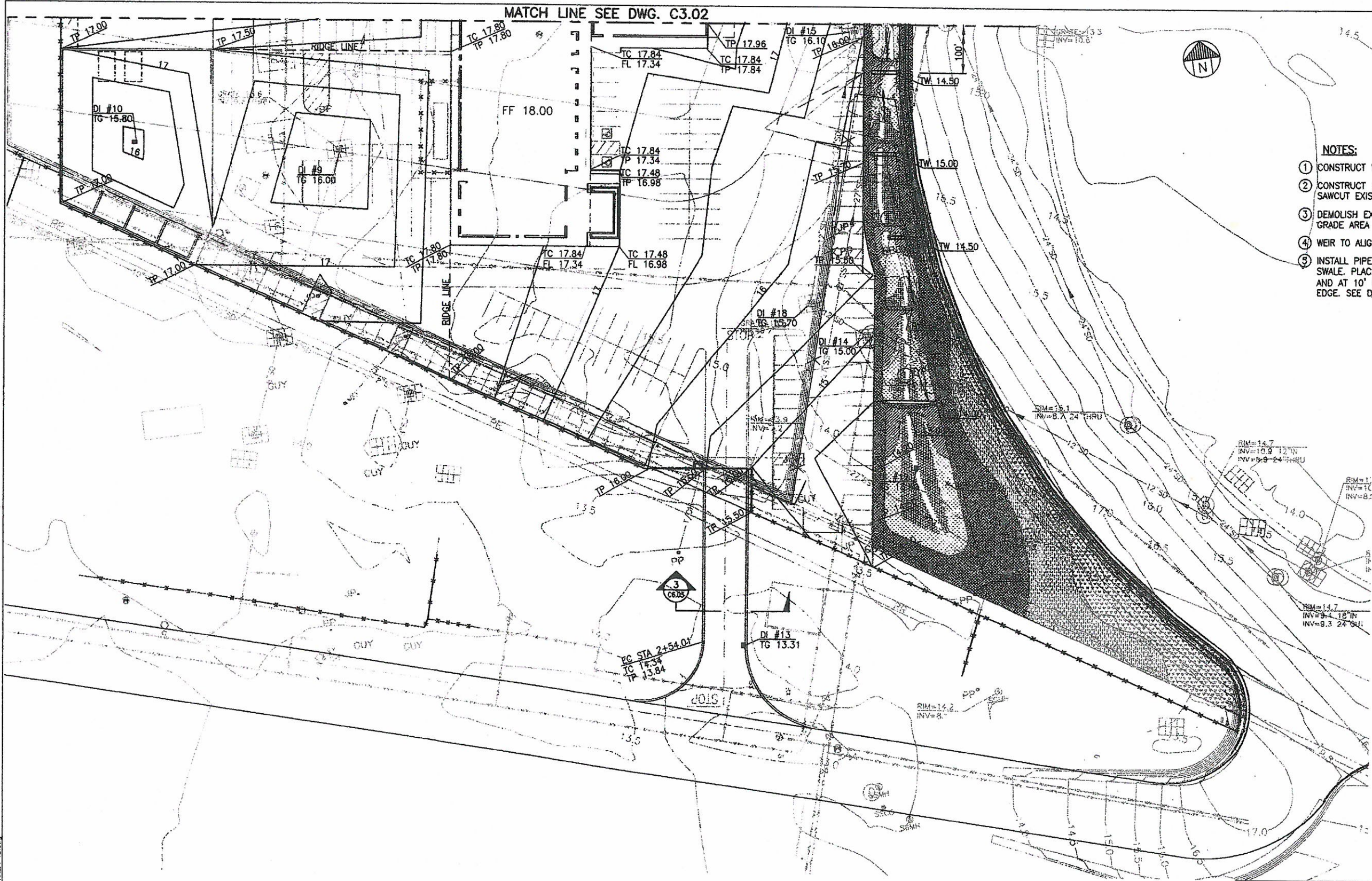

- NOTES:**
- ① CONSTRUCT BIORETENTION WEIR, SEE DETAIL 1
 - ② CONSTRUCT 135'+/- (VERIFY IN FIELD) CURB SAWCUT EXIST PAVEMENT. GRADES TO MATCH E
 - ③ DEMOLISH EXISTING DRIVE ENTRY PAVING AND GRADE AREA TO DRAIN.
 - ④ WEIR TO ALIGN WITH COLUMN LINE A. SPACE WEIR
 - ⑤ INSTALL PIPE BOLLARD AT PAVEMENT EDGE ALSO SWALE. PLACE BOLLARD AT CENTER OF EACH F AND AT 10' INTERVALS ALONG REMAINING PAVED EDGE. SEE DETAIL ON C3.02

FILE: \\DRAWINGS\2K1008\C-GRADE.dwg 01/31/03 at 11:29
 XREF: A101.dwg
 XREF: DWYBldg.dwg
 XREF: SECOND EASEMENT.dwg
 XREF: TOWER.dwg
 XREF: TOWER-FAC.dwg
 XREF: TOWER.dwg
 XREF: TOWER.dwg

NO.	REVISIONS	DATE	APP'D

REVIEWED	AA	
REVIEWED	FACILITIES DEPARTMENT	
REVIEWED	CONSTRUCTION DEPARTMENT	
REVIEWED	PROJECT PLANNING DEPARTMENT	

DRAWN M. KYAW
 DESIGNED E. SLINTAK
 CHECKED R.T. WONG
 REVIEWED M. KORSUNSKY

PORT OF OAKLAND
 530 WATER ST. OAKLAND, CALIFORNIA

CHIEF ENGINEER
 APPROVED
 RECOMMENDED

Michael Willis Architects
 471 Ninth Street
 Oakland, CA 94607
 tel: (510) 287-9710

AGS, Inc.
 Consulting Engineers
 354-14th Street, Ste. FL
 Oakland, CA 94612
 Tel: (510) 251-1180
 Fax: (510) 251-1190

MARITIME & 7TH STREET SITE
 PORT FIELD SUPPORT SERVICES COMPLEX
 GRADING PLAN

CAUTION: THIS PLAN MAY BE REDUCED ORIGINAL SCALE

Attachment 2

Soil gas mitigation system as-built drawings

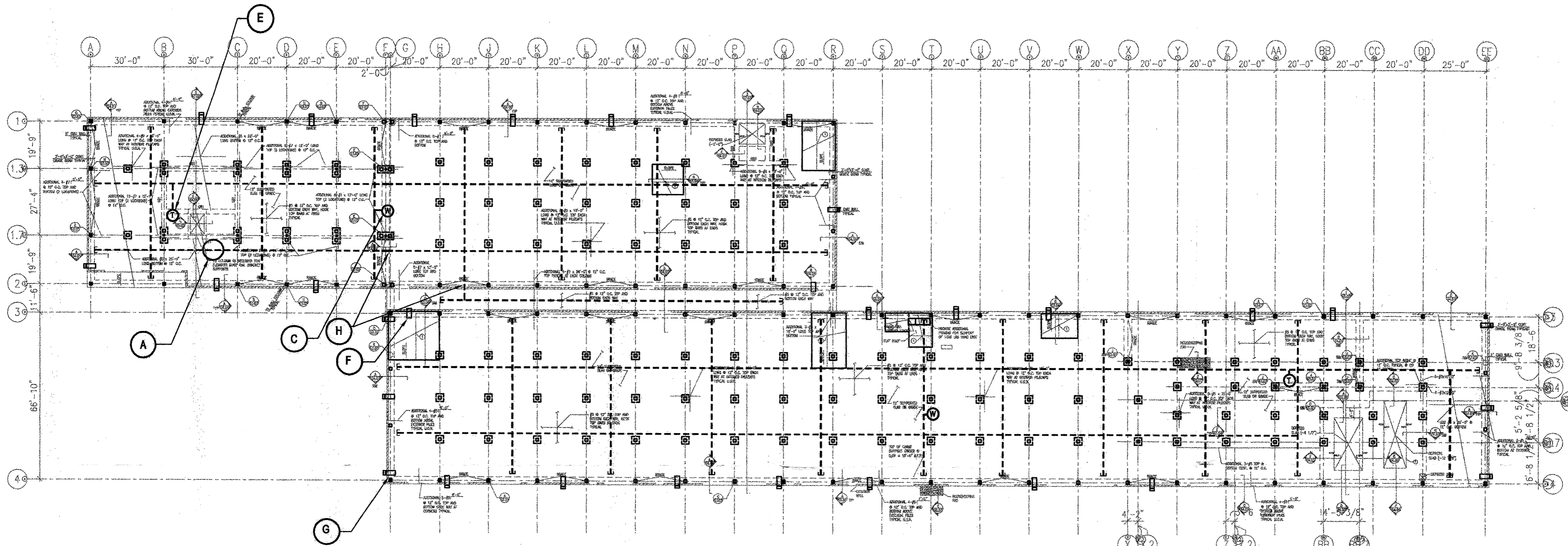

1 SUBFLOOR SOIL GAS VENT PIPING SCHEMATIC
SCALE: 1" = 20'-0"

LEGEND

- 4" DIAMETER SCHEDULE 40 SOLID PVC PIPE
- - - 4" DIAMETER SCHEDULE 40 PERFORATED PVC PIPE
- ⌋ END CAP
- ▭ PERIMETER GRADE BEAM VENT
- ▭ INTERIOR GRADE BEAM VENT
- ⊙ WIND ASSISTED RISER; INSTALL IN DESIGNATED WALL (SEE ARCHITECTURAL DRAWINGS FOR EXACT LOCATION)
- ⊙ UNDERSLAB SOIL GAS TEST PORT (SEE ARCHITECTURAL DRAWINGS FOR EXACT LOCATION)
- ⊙ SEE DETAIL A, SHEET MT2.01

KEY PLAN

4000.01_Soil-Gas_Mt_System.dwg

REFERENCES:

PLANS	AA
FIELD BOOKS	
"PORT OF OAKLAND DATUM" IS 3.20' BELOW MEAN SEA LEVEL	
CAUTION: CHECK TRACING FOR LATEST REVISIONS	

NO.	REVISIONS	DATE	APP'D
AS BUILT		07/05	

REVIEWED	FACILITIES DEPARTMENT
REVIEWED	CONSTRUCTION DEPARTMENT
REVIEWED	PROJECT PLANNING DEPARTMENT

DRAWN	GEL
DESIGNED	BKM
CHECKED	BKM
REVIEWED	BKM

PORT OF OAKLAND
530 WATER ST. OAKLAND, CALIFORNIA

CHIEF ENGINEER	
APPROVED	
RECOMMENDED	

Michael Willis Architects
471 Ninth Street
Oakland, CA 94607
tel:(510) 287-9710

Treadwell & Rollo
Environmental and Geotechnical Consultants
655 Montgomery Street, Suite 1300
San Francisco, California

MARITIME & 7TH STREET SITE	DATE: 07/13/05
HARBOR FACILITIES CENTER	SCALE:
SOIL GAS MITIGATION SYSTEM - PLAN	SHEET: 19 OF 203 SHEETS

MT1.01	AA-3827
--------	---------

CAUTION: THIS PLAN MAY BE REDUCED ORIGINAL SCALE

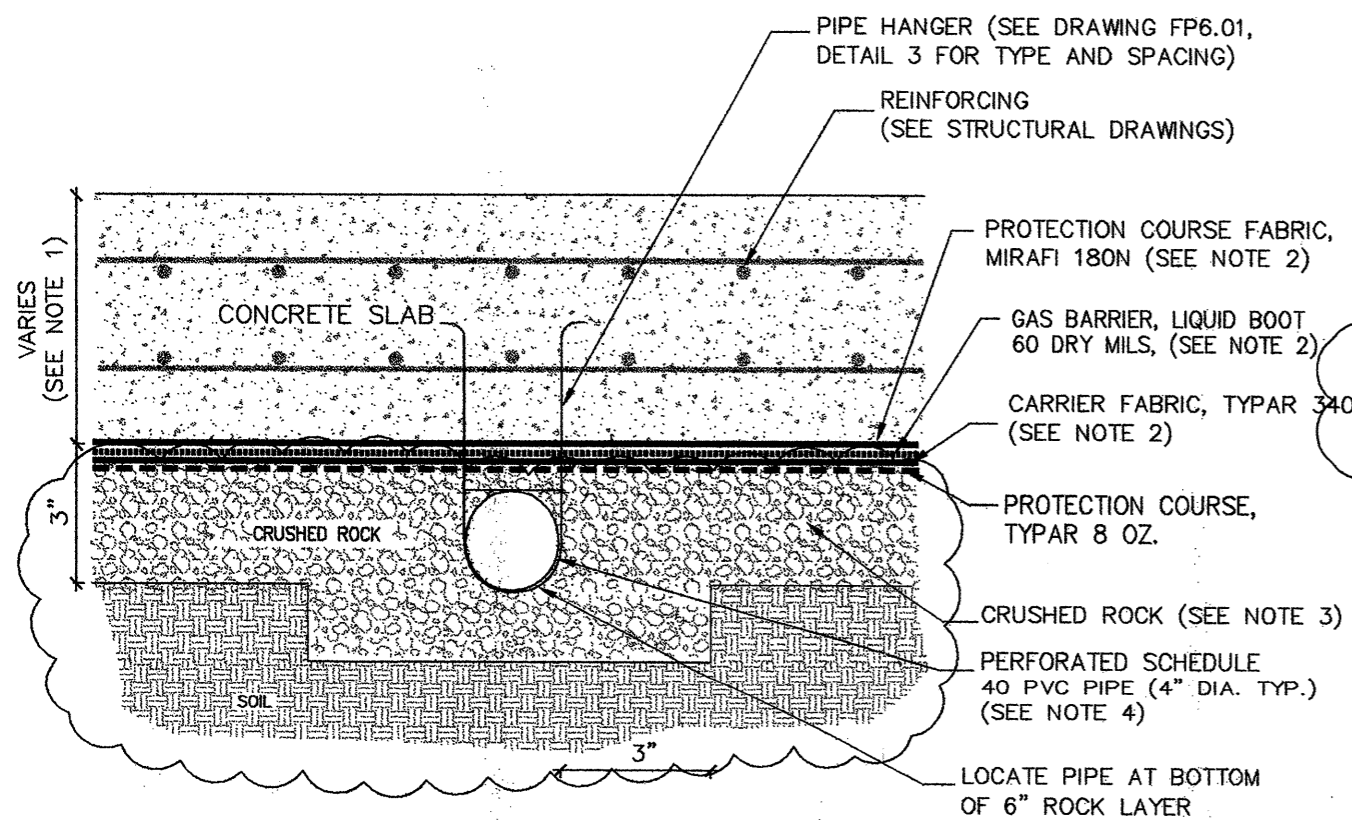

A SOIL GAS COLLECTION SYSTEM LATERAL
 NOT TO SCALE

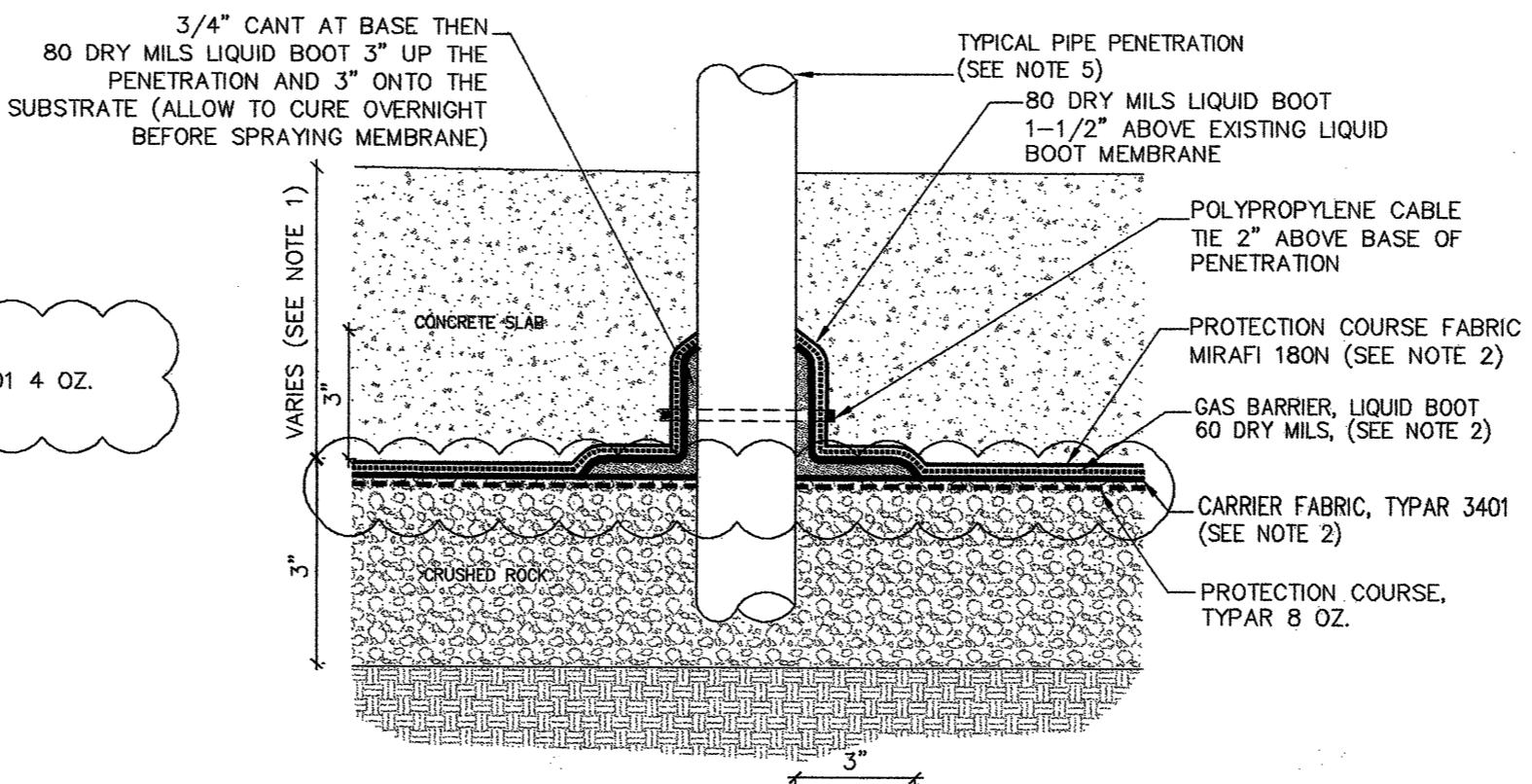

B TYPICAL SEALING OF ALL PENETRATIONS THROUGH CONCRETE SLAB
 NOT TO SCALE

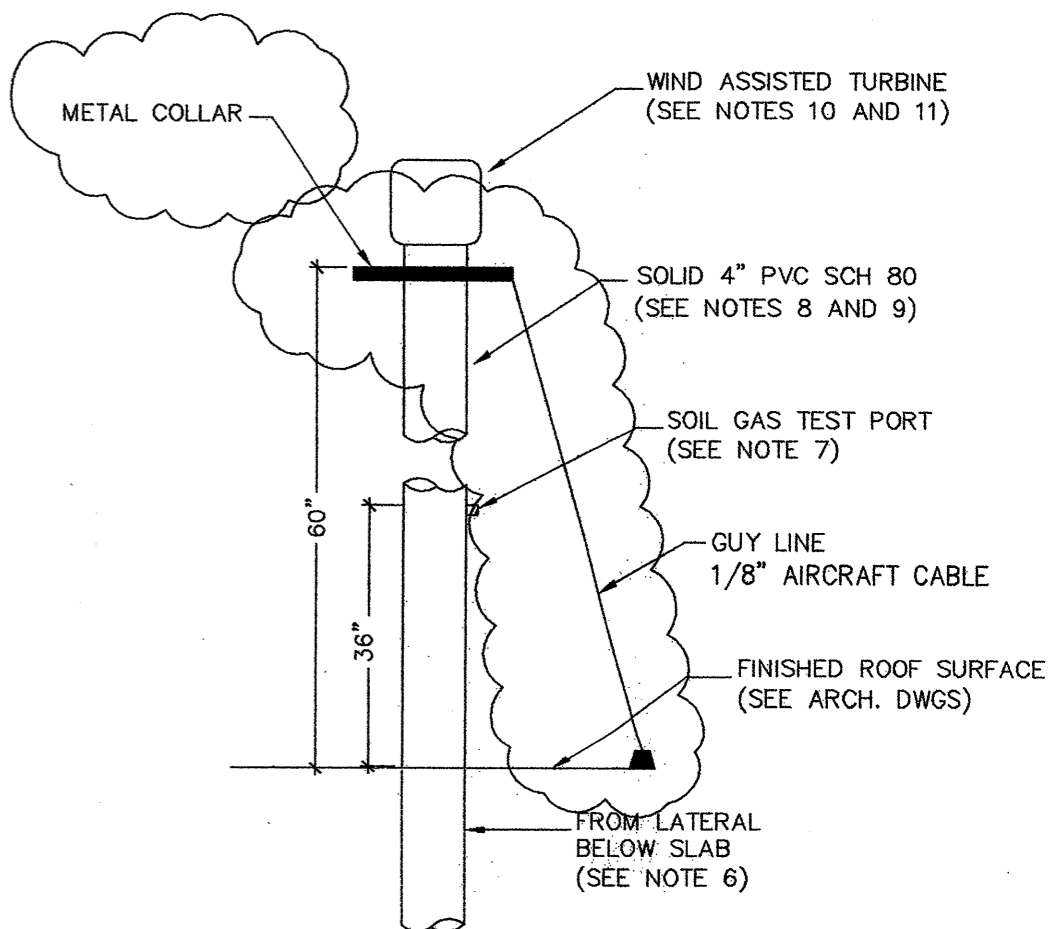

C RISER AND TURBINE AT ROOF
 NOT TO SCALE

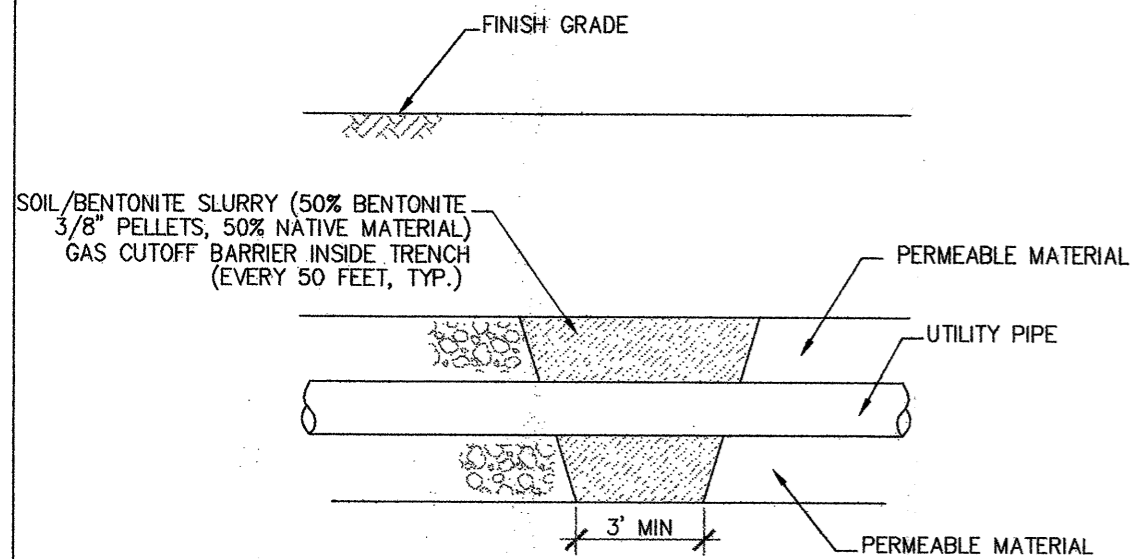

D UTILITY SOIL GAS CUT-OFF BARRIER IN UTILITY TRENCH
 NOT TO SCALE

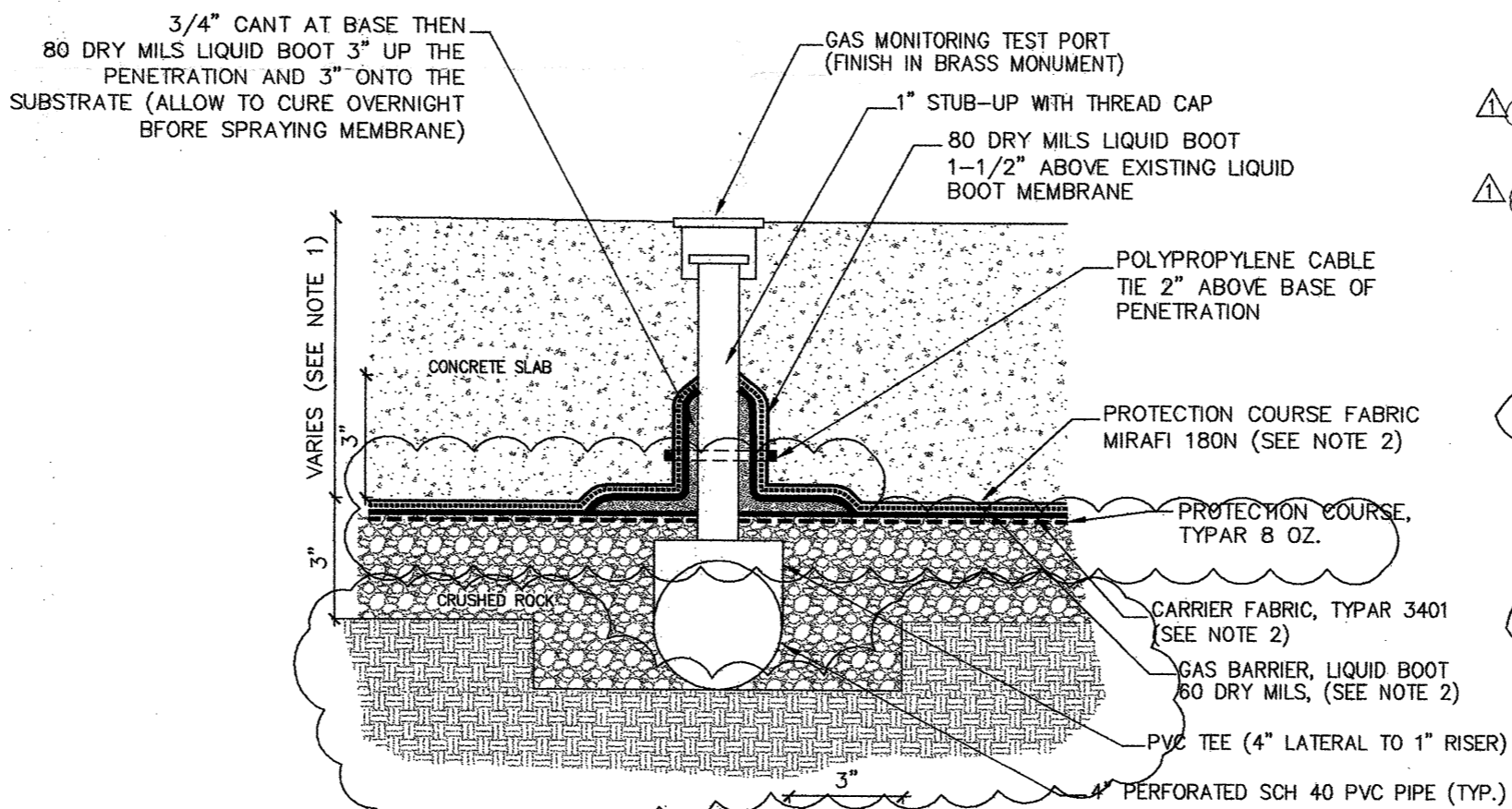

E SOIL GAS TEST PORT
 NOT TO SCALE

NOTES:

- ALL LOCATIONS AND DIMENSIONS OF BUILDING SLABS, FOOTINGS, AND GRADE BEAMS TO BE CONFIRMED WITH STRUCTURAL DETAILS.
- THE LIQUID BOOT SHALL BE INSTALLED ACCORDING TO MANUFACTURER'S SPECIFICATIONS AND QA/QC REQUIREMENTS, OUTLINED IN SECTION 07141 FLUID APPLIED BARRIER SYSTEM BY A MANUFACTURER APPROVED APPLICATOR. SLAB PENETRATIONS SHALL NOT BE IN CONTACT WITH AN ADJACENT PENETRATION THAT WOULD PREVENT PROPER SEALING OF THE PENETRATION CIRCUMFERENCE. PROTECTION COURSE FABRIC SHALL BE MIRAFI 180N NON-WOVEN GEOTEXTILE. CARRIER FABRIC SHALL BE TYPAR 3401, WITH THE HEAT-TREATED SIDE FACING THE LIQUID BOOT.
- CRUSHED ROCK SHALL BE 1/4" X 3/4" SURFACE OF CRUSHED ROCK LAYER SHALL BE SMOOTH-ROLLED PRIOR TO APPLICATION OF THE CARRIER FABRIC.
- THE HORIZONTAL PIPE SHALL BE OF SCHEDULE 40 PVC, HANGOR SMOOTHWALL DRAIN PIPE, OR SIMILAR QUALITY PLASTIC PIPE. INDICATED SECTIONS OF HORIZONTAL PIPE SHALL BE PERFORATED WITH 5/8 INCH DIAMETER HOLES, THREE HOLES ACROSS THE UPPER ONE-THIRD OF THE PIPE. EVERY THREE INCHES ALONG THE PERFORATED SECTION; AN ADDITIONAL 5/8 INCH DIAMETER HOLE SHALL BE DRILLED ON THE UNDERSIDE OF THE PIPE AT LEAST EVERY 2 LINEAR FEET ALONG THE PERFORATED SECTION TO ALLOW WATER, IF ANY, TO DRAIN FROM THE PIPE.
- SLAB PENETRATION SHALL NOT BE IN CONTACT WITH ADJACENT PENETRATIONS OR STEEL COLUMNS TO ALLOW TROWEL GRADE LIQUID BOOT APPLICATION AROUND ENTIRE PENETRATION CIRCUMFERENCE.
- THE VERTICAL RISER PIPE TO THE WIND TURBINE SHALL BE SUPPORTED AT THE PIPE CHASE WALLS AND LABELED AS "CONTAINS COMBUSTIBLE GAS; DO NOT BREAK OR CUT".
- A TEST PORT SHALL BE INSTALLED TO SAMPLE AIR FROM THE COLLECTION PIPE 36 INCHES ABOVE ROOF LEVEL.
- THE VERTICAL RISER PIPE TO THE WIND-ASSISTED TURBINE VENT SHALL BE 4 INCH DIAMETER SCHEDULE 80 PVC AND EXTEND TO AN ELEVATION 15 FEET ABOVE THE ROOF LEVEL.
- PROVIDE 1-INCH DIAMETER ELECTRICAL CONDUIT TO RISER FOR POSSIBLE FUTURE POWER NEEDS TO A MECHANICAL VACUUM BLOWER. COORDINATE WITH ELECTRICAL DRAWINGS.
- THE WIND-ASSISTED TURBINE VENT ON TOP OF THE 4 INCH PVC RISER SHALL BE 24 INCH DIA. GALVANIZED STEEL (McMASTER-CARR CAT# 1992K24) AND SHALL BE INDEPENDENTLY SUPPORTED FROM PVC RISER.
- TURBINE SHALL BE ADAPTED TO FIT A 4 INCH PIPE.
- PIPE PENETRATIONS THROUGH THE PERIMETER GRADE-BEAM SHALL BE OF SCHEDULE 80 PVC. THE VENT PIPE CAP SHALL KEEP OUT DEBRIS BUT ALLOW AIR TO ENTER THE PIPE. CONTRACTOR SHALL COORDINATE PLACEMENT OF PIPING INSIDE EXTERIOR WALL WITH ARCHITECT AND SUBMIT SAMPLE CAP TO ARCHITECT FOR APPROVAL. VENTS SHALL BE LOCATED A MINIMUM OF 36 INCHES AWAY FROM DOOR JAMS.
- FOUR 1/8" AIRCRAFT CABLES USED TO SECURE RISER TO PREVENT EXCESSIVE MOVEMENT.

4000.01_Soil-Gas_MIT_Details_2.01 to 03.dwg

REFERENCES:	NO.	REVISIONS	DATE	APP'D
PLANS AA ...		AS BUILT	7/05	
FIELD BOOKS				
"PORT OF OAKLAND DATUM" IS 3.20' BELOW MEAN SEA LEVEL				
CAUTION: CHECK TRACING FOR LATEST REVISIONS		ADDITIONAL POST-BID REVISIONS		

REVIEWED	FACILITIES DEPARTMENT	DRAWN	GEL
REVIEWED	CONSTRUCTION DEPARTMENT	DESIGNED	BKM
REVIEWED	PROJECT PLANNING DEPARTMENT	CHECKED	BKM
		REVIEWED	BKM

PORT OF OAKLAND
 530 WATER ST. OAKLAND, CALIFORNIA

CHIEF ENGINEER	
APPROVED	
RECOMMENDED	

Michael Willis Architects
 471 Ninth Street
 Oakland, CA 94607
 tel: (510) 287-9710

Treadwell & Rollo
 Environmental and Geotechnical Consultants
 555 Montgomery Street, Suite 1300
 San Francisco, California

MARITIME & 7TH STREET SITE
 HARBOR FACILITIES CENTER
 SOIL GAS MITIGATION SYSTEM - DETAILS

DATE: 07/13/05
 SCALE:
 SHEET: 20A OF 203 SHEETS
 MT2.01 AA-3827

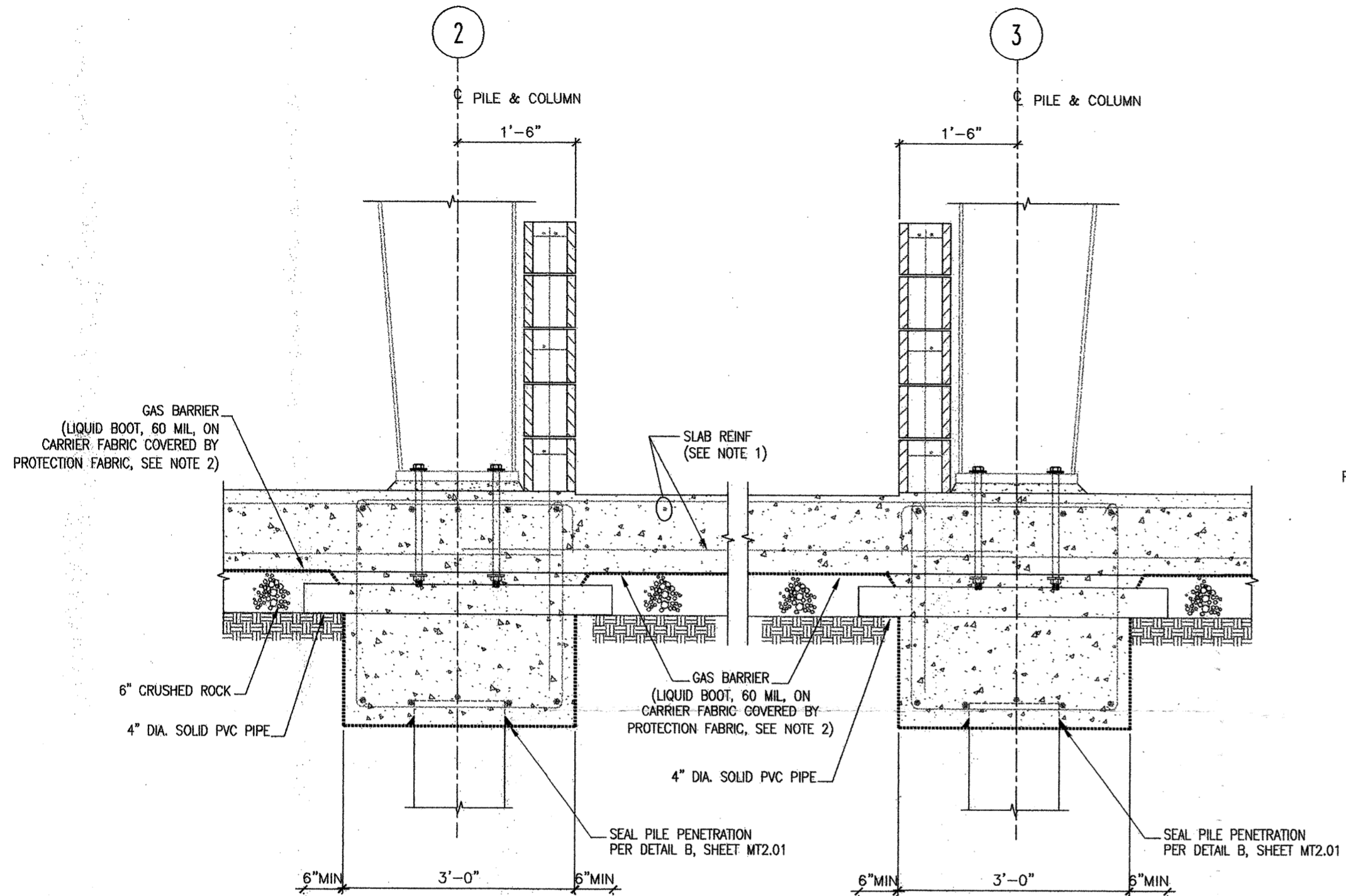

F INTERIOR VENT THROUGH INTERIOR GRADE BEAM
SCALE: 1" = 1'-0"

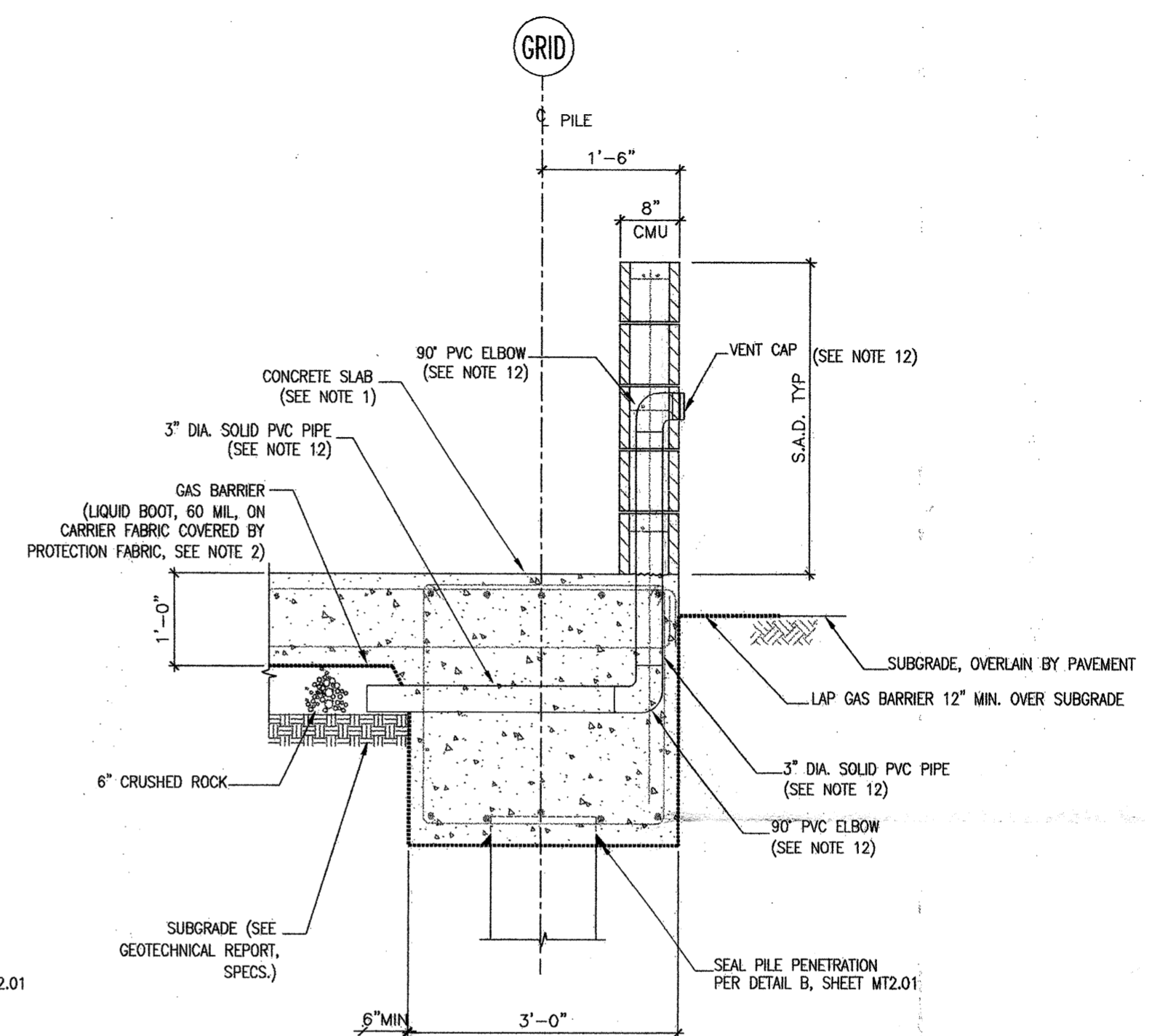

G EXTERIOR VENT THROUGH PERIMETER GRADE BEAM
SCALE: 1" = 1'-0"

4000.01_Soil-Gas_MT_DETAILS_2.01 to 03.dwg

REFERENCES:	NO.	REVISIONS	DATE	APP'D
PLANS	AA	AS BUILT	7/05	
FIELD BOOKS				
"PORT OF OAKLAND DATUM" IS 3.20' BELOW MEAN SEA LEVEL				
CAUTION: CHECK TRACING FOR LATEST REVISIONS				

REVIEWED	FACILITIES DEPARTMENT	DRAWN	GEL
REVIEWED	CONSTRUCTION DEPARTMENT	DESIGNED	BKM
REVIEWED	PROJECT PLANNING DEPARTMENT	CHECKED	BKM
		REVIEWED	BKM

PORT OF OAKLAND
530 WATER ST. OAKLAND, CALIFORNIA

CHIEF ENGINEER	
APPROVED	
RECOMMENDED	

Michael Willis Architects
471 Ninth Street
Oakland, CA 94607
tel: (510) 287-9710

Treadwell&Rollo
Environmental and Geotechnical Consultants
555 Montgomery Street, Suite 1300
San Francisco, California

MARITIME & 7TH STREET SITE	DATE: 07/13/05
HARBOR FACILITIES CENTER	SCALE:
SOIL GAS MITIGATION SYSTEM - DETAILS	SHEET: 21 OF 203 SHEETS
MT2.02	AA-3827

CAUTION: THIS PLAN MAY BE REDUCED ORIGINAL SCALE

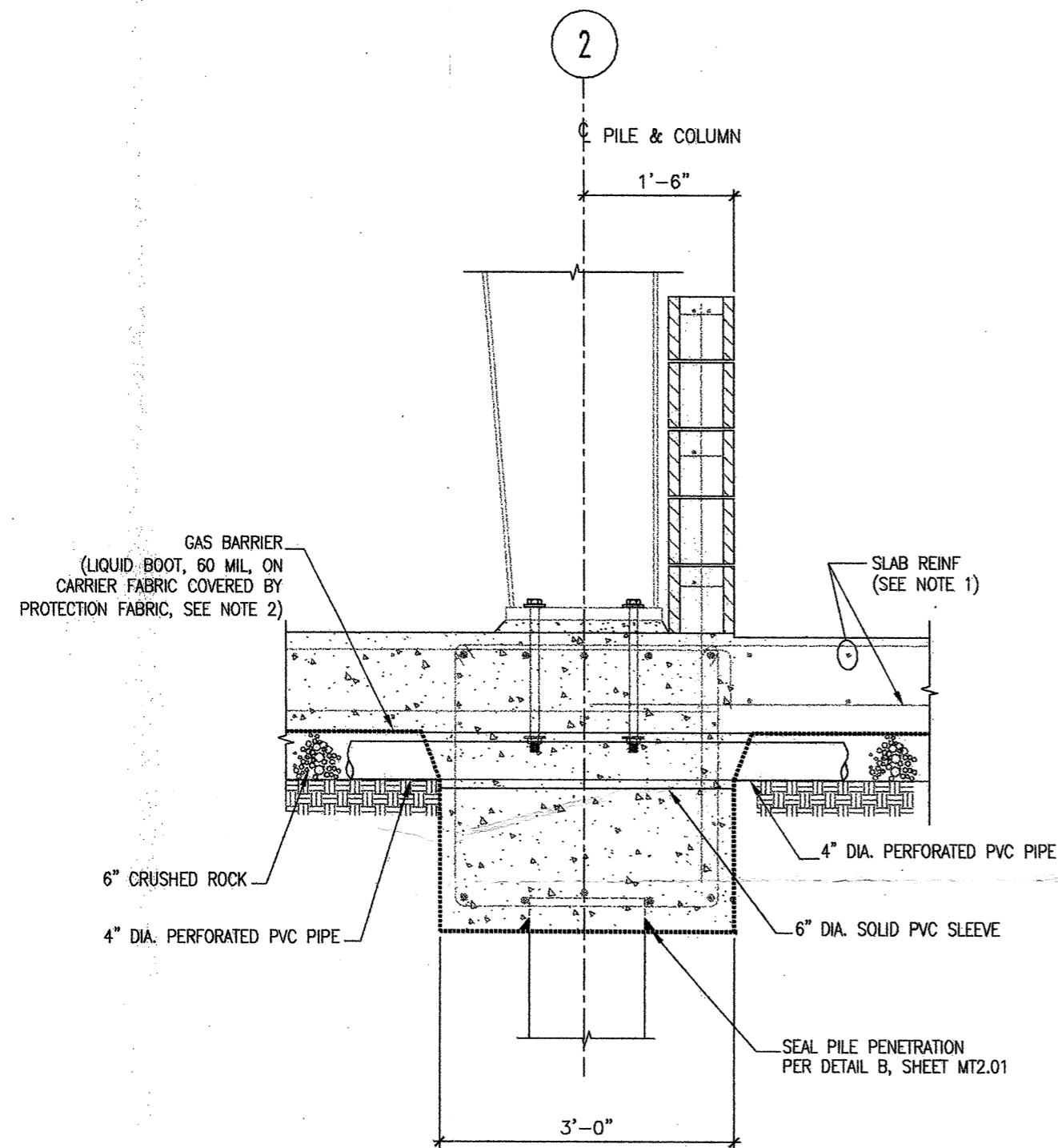

H PIPING PENETRATION THROUGH INTERIOR GRADE BEAM
SCALE: 1" = 1'-0"

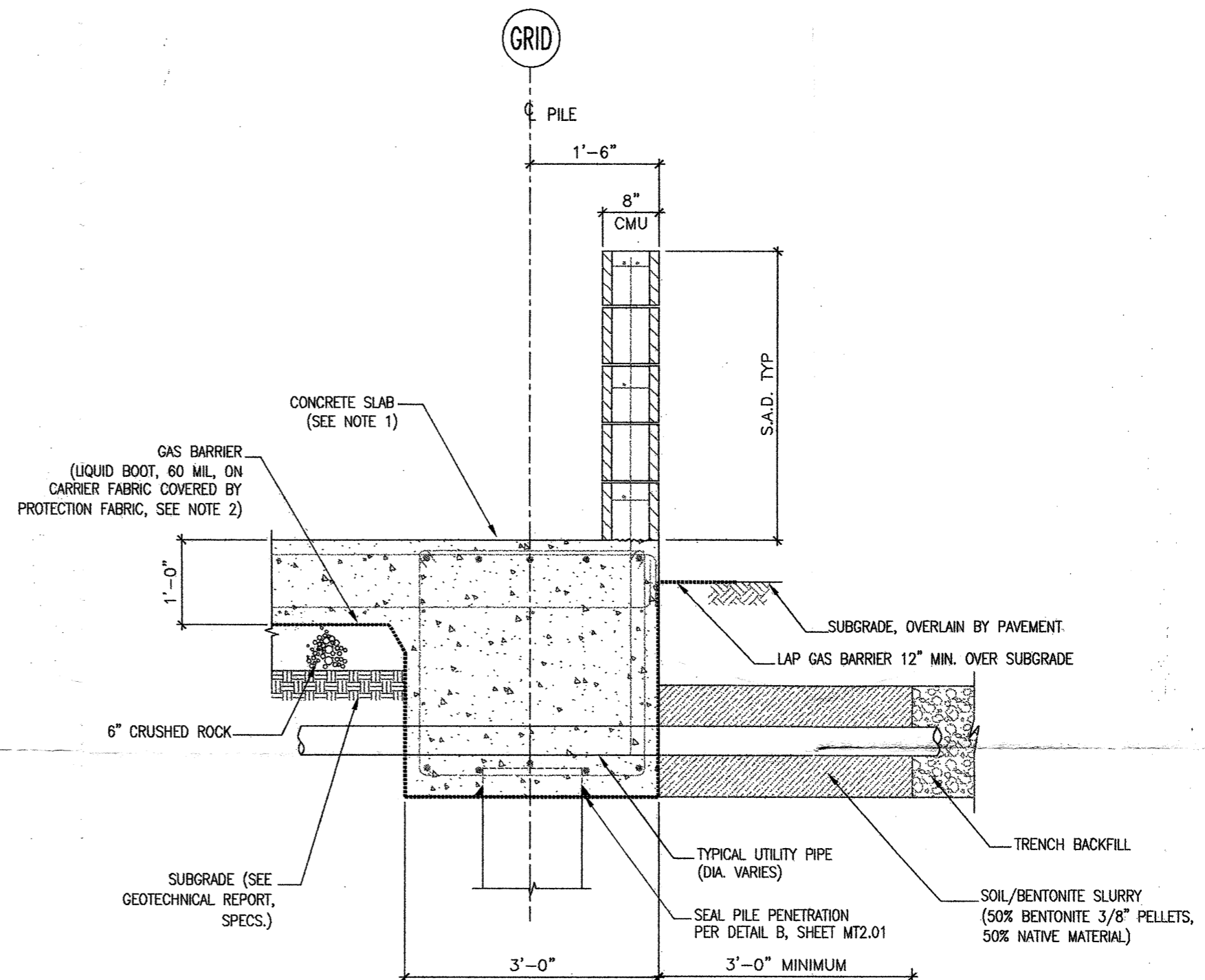

I TYPICAL UTILITY TRENCH CUTOFF @ PERIMETER GRADE BEAM
SCALE: 1" = 1'-0"

4000.01_Soil-Gas_MIT_DETAILS_2.01 to 03.dwg

REFERENCES:	NO.	REVISIONS	DATE	APP'D
PLANS	AA	AS BUILT	7/05	
FIELD BOOKS				
"PORT OF OAKLAND DATUM" IS 3.20' BELOW MEAN SEA LEVEL				
CAUTION: CHECK TRACING FOR LATEST REVISIONS				

REVIEWED	FACILITIES DEPARTMENT
REVIEWED	CONSTRUCTION DEPARTMENT
REVIEWED	PROJECT PLANNING DEPARTMENT

DRAWN	GEL
DESIGNED	BKM
CHECKED	BKM
REVIEWED	BKM

PORT OF OAKLAND
530 WATER ST. OAKLAND, CALIFORNIA

CHIEF ENGINEER	
APPROVED	
RECOMMENDED	

Michael Willis Architects
471 Ninth Street
Oakland, CA 94607
tel: (510) 287-9710

Treadwell & Rollo
Environmental and Geotechnical Consultants
555 Montgomery Street, Suite 1300
San Francisco, California

MARITIME & 7TH STREET SITE	DATE: 07/13/05
HARBOR FACILITIES CENTER	SCALE:
SOIL GAS MITIGATION SYSTEM - DETAILS	SHEET: 22 OF 203 SHEETS

MT2.03	AA-3827
--------	---------

CAUTION: THIS PLAN MAY BE REDUCED ORIGINAL SCALE

Attachment 3

Soil gas mitigation system annual monitoring data

Harbor Facilities Complex Passive Methane Abatement System Check
651 Maritime Street, Oakland
Port of Oakland

Date: Wednesday, May 20, 2009

T-1

Auto Maintenance Shop
Sample port behind drill press underneath stairs.

Methane: 0.0 ppm

Air flow rate: 27 ft/min

Pressure: -0.03 in/H₂O

T-2

Under stairwell in office building.

Methane: 0.0 ppm

Air flow rate: 30 ft/min

Pressure: 0.0 in/H₂O

W-1

Welding Shop
Sample port is behind grey panel next to fuse box on north wall.

Methane: 0.0 ppm

Air flow rate: 250 ft/min

Pressure: 0.0 in/H₂O

W-2

Warehouse
Sample port on riser.

Methane: 0.0 ppm

Air flow rate: 200 ft/min

Pressure: 0.0 in/H₂O

Harbor Facilities Complex Passive Methane Abatement System Check
651 Maritime Street, Oakland
Port of Oakland

Date: 6/23/10 Recorded by: Caroline Orsi

Contact Lawrence Dirksen to arrange access:
510-627-1653 cell: 510-773-9977
ldirksen@portoakland.com

Verified that wind turbines are turning

T-1

Auto Maintenance Shop
Sample port behind drill press underneath stairs

FID reading w/out carbon filter: 0.0 ppm

FID reading with carbon filter: 0.0 ppm

Air flow rate: 0.59 mps Direction: ~~in~~ into port

T-2

Under stairwell in office building

FID reading w/out carbon filter: 0.0 ppm

FID reading with carbon filter: 0.0 ppm

Air flow rate: 0.0 mps inside Direction: into port
(0.40 mps into port)

W-1

Welding shop
Sample port is behind grey panel next to fuse box on north wall

FID reading w/out carbon filter: 0.0 ppm

FID reading with carbon filter: 0.0 ppm

Air flow rate: 0.92 mps Direction: up

W-2

Warehouse
Sample port on riser

FID reading w/out carbon filter: 0.0 ppm

FID reading with carbon filter: 0.0 ppm

Air flow rate: 0.89 mps Direction: up

Harbor Facilities Complex Passive Methane Abatement System Check
651 Maritime Street, Oakland
Port of Oakland

Date: 6/24/11 Recorded by: Caroline Orsi

Contact Lawrence Dirksen to arrange access:
510-627-1653
ldirksen@portoakland.com

Are roof wind turbines turning? Yes/No

~~W-1~~ T-2
Auto Maintenance Shop
Sample port behind drill press underneath stairs

FID reading w/out carbon filter: 0.0 ppm with carbon filter: 0.0 ppm

Air flow rate: 121 ft/min | 242 ft/min Direction: into pipe
 ↓ ↓
 inside port into pipe

~~W-1~~ W-1
Under stairwell in office building

FID reading w/out carbon filter: 0.0 ppm with carbon filter: 0.0 ppm

Air flow rate: 202 ft/min Direction: up

~~W-1~~ T-1
Welding shop
Sample port is behind grey panel next to fuse box on north wall

FID reading w/out carbon filter: 0.0 ppm with carbon filter: 0.0 ppm

Air flow rate: 27 | 172 Direction: in

W-2
Warehouse
Sample port on riser

FID reading w/out carbon filter: 0.0 ppm with carbon filter: 0.0 ppm

Air flow rate: 169 ft/min Direction: up

Harbor Facilities Complex Passive Methane Abatement System Check
651 Maritime Street, Oakland
Port of Oakland

Date: 6/19/12 Recorded by: Caroline Orsi

Contact Lawrence Dirksen to arrange access:
510-627-1653
ldirksen@portoakland.com

Are roof wind turbines turning? Yes/No

T-1
Auto Maintenance Shop
Sample port behind drill press underneath stairs

FID reading w/out carbon filter: 0.0 with carbon filter: 0.0

Air flow rate: NA Direction: in

T-2
Under stairwell in office building

FID reading w/out carbon filter: 0.0 with carbon filter: 0.0

Air flow rate: NA Direction: in

W-1
Welding shop
Sample port is behind grey panel next to fuse box on north wall

FID reading w/out carbon filter: 0.0 with carbon filter: 0.0

Air flow rate: NA Direction: up

W-2
Warehouse
Sample port on riser

FID reading w/out carbon filter: 0.0 with carbon filter: 0.0

Air flow rate: NA Direction: up

Harbor Facilities Complex Passive Methane Abatement System Check
651 Maritime Street, Oakland
Port of Oakland

Date: 6/20/13 Recorded by: C. Orsi

Contact Lawrence Dirksen to arrange access:
510-627-1653
ldirksen@portoakland.com

Are roof wind turbines turning? Yes/No

T-1
Auto Maintenance Shop
Sample port behind drill press underneath stairs

FID reading w/out carbon filter: 0.0 ppm with carbon filter: 0.0 ppm

Air flow rate: 241 ft/min Direction: In

T-2
Under stairwell in office building

FID reading w/out carbon filter: 0.0 ppm with carbon filter: 0.0 ppm

Air flow rate: 255 ft/min Direction: In

W-1
Welding shop
Sample port is behind grey panel next to fuse box on north wall

FID reading w/out carbon filter: 0.0 ppm with carbon filter: 0.0 ppm

Air flow rate: 145 ft/min Direction: up

W-2
Warehouse
Sample port on riser

FID reading w/out carbon filter: 0.0 ppm with carbon filter: 0.0 ppm

Air flow rate: 98 ft/min Direction: up



**Harbor Facilities Complex Passive Methane Abatement System Check
651 Maritime Street, Oakland
Port of Oakland**

Date: 01/13/14 Recorded by: Caroline Orsi

Contact Lawrence Dirksen to arrange access:
510-627-1653
ldirksen@portoakland.com

Are roof wind turbines turning? Yes No

T-1

Auto Maintenance Shop
Sample port behind drill press underneath stairs

FID reading w/out carbon filter: 0.0 ppm with carbon filter: 0.0 ppm

Air flow rate: 203 ft/min Direction: in

T-2

Under stairwell in office building

FID reading w/out carbon filter: 0.0 ppm with carbon filter: 0.0 ppm

Air flow rate: 129 ft/min Direction: in

W-1

Welding shop
Sample port is behind grey panel next to fuse box on north wall

FID reading w/out carbon filter: 0.0 ppm with carbon filter: 0.0 ppm

Air flow rate: 116 ft/min Direction: up

W-2

Warehouse
Sample port on riser

FID reading w/out carbon filter: 0.0 ppm with carbon filter: 0.0 ppm

Air flow rate: 42 ft/min Direction: up

Attachment 4

Well construction details

TABLE 1. Well Construction Details
 Port of Oakland's Harbor Facilities Complex Site
 555 - 651 Maritime Street, Oakland, California

Well ID	Date Installed	Date Destroyed	Top of Screen (ft bgs)	Bottom of Screen (ft bgs)	Sump	Diameter (inches)	Well Material	BEFORE RE-GRADE		AFTER RE-GRADE		Top of Screen (ft amsl)
								Top of Casing Elevation (ft amsl)	Date measured	Top of Casing Elevation (ft amsl)	Date measured	
MW-1 ¹	12/16/1992	2002 ²	5	15	--	4	PVC	13.72	NA	--	--	8.72
MW-2 ¹	12/16/1992	2002 ²	5	15	--	4	PVC	13.8	NA	--	--	8.8
MW-3 ¹	12/16/1992	2002 ²	5	15	--	4	PVC	15.06	NA	--	--	10.06
MW-1	5/16/1994	--	5.5	15.5	--	2	PVC	13.65	1995	15.8	1/24/2009	8.15
MW-2	5/16/1994	--	5.5	15.5	--	2	PVC	13.87	1995	16.43	1/24/2009	8.37
MW-3	5/16/1994	--	5.5	15.5	--	2	PVC	13.73	1995	15.66	1/24/2009	8.23
MW-4	8/25/1995	--	8	18	--	2	PVC	12.66	1995	15.91	1/24/2009	4.66
MW-5	8/25/1995	--	8	18	--	2	PVC	13.00	1995	15.39	1/24/2009	5
MW-6	8/25/1995 ³	12/18/2002	8 ³	18 ³	--	2	PVC	13.51	1995	--	--	5.51
MW-7	8/25/1995	12/18/2002	8	18	--	2	PVC	13.86	1995	--	--	5.86
MW-8	8/25/1995	11/21/1998	8	18	--	2	PVC	12.45	1995	--	--	4.45
MW-8A	10/2/2001	--	5	1/20/1900	--	NA	NA	12.45	1995	14.99	1/24/2009	7.45
MW-9	12/1/2008	--	15	25	--	2	PVC	--	--	16.33	1/24/2009	1.33
MW-10	12/1/2008	--	15	25	--	2	PVC	--	--	15.65	1/24/2009	0.65
MW-11	12/1/2008	--	15	25	--	2	PVC	--	--	15.47	1/24/2009	0.47
MW-12	12/2/2008	--	15	25	--	2	PVC	--	--	16.79	1/24/2009	1.79
RW-1	4/28/2004	--	5	15	15-18	4	PVC	NA	--	12.95	1/24/2009	NA
RW-2	4/28/2004	--	8	18	18-21	4	PVC	NA	--	15.56	1/24/2009	NA
RW-3	4/26/2004	--	8	18	18-21	4	PVC	NA	--	15.56	1/24/2009	NA
RW-4	4/26/2004	--	8	18	18-21	4	PVC	NA	--	14.92	1/24/2009	NA
RW-5	4/27/2004	--	8	18	18-21	4	PVC	NA	--	14.79	1/24/2009	NA
RW-6	4/27/2004	--	8	18	18-21	4	PVC	NA	--	15.75	1/24/2009	NA
RW-7	4/26/2004	--	8	18	18-21	4	PVC	NA	--	15.02	1/24/2009	NA
RW-8	4/28/2004	--	9	19	19-22	4	PVC	NA	--	15.91	1/24/2009	NA
RW-9	4/27/2004	--	9	19	19-22	4	PVC	NA	--	16.57	1/24/2009	NA

NOTES

ft bgs = feet below ground surface

ft amsl = feet above mean sea level

PVC = poly vinyl chloride

1 = offsite wells from 2255 7th Street (Ringsby Terminals Inc.)

2 = referenced in a March 2006 Request for Reduction in Groundwater Monitoring Frequency

3 = assumed

NA = Not Available

-- = Not Applicable

-Site re-graded in 2006 (before 11/29/06)

Attachment 5

All available boring logs

From March 1993 Soil & GW Inv. @ 2225 7th St.

GROUND WATER MONITOR WELL

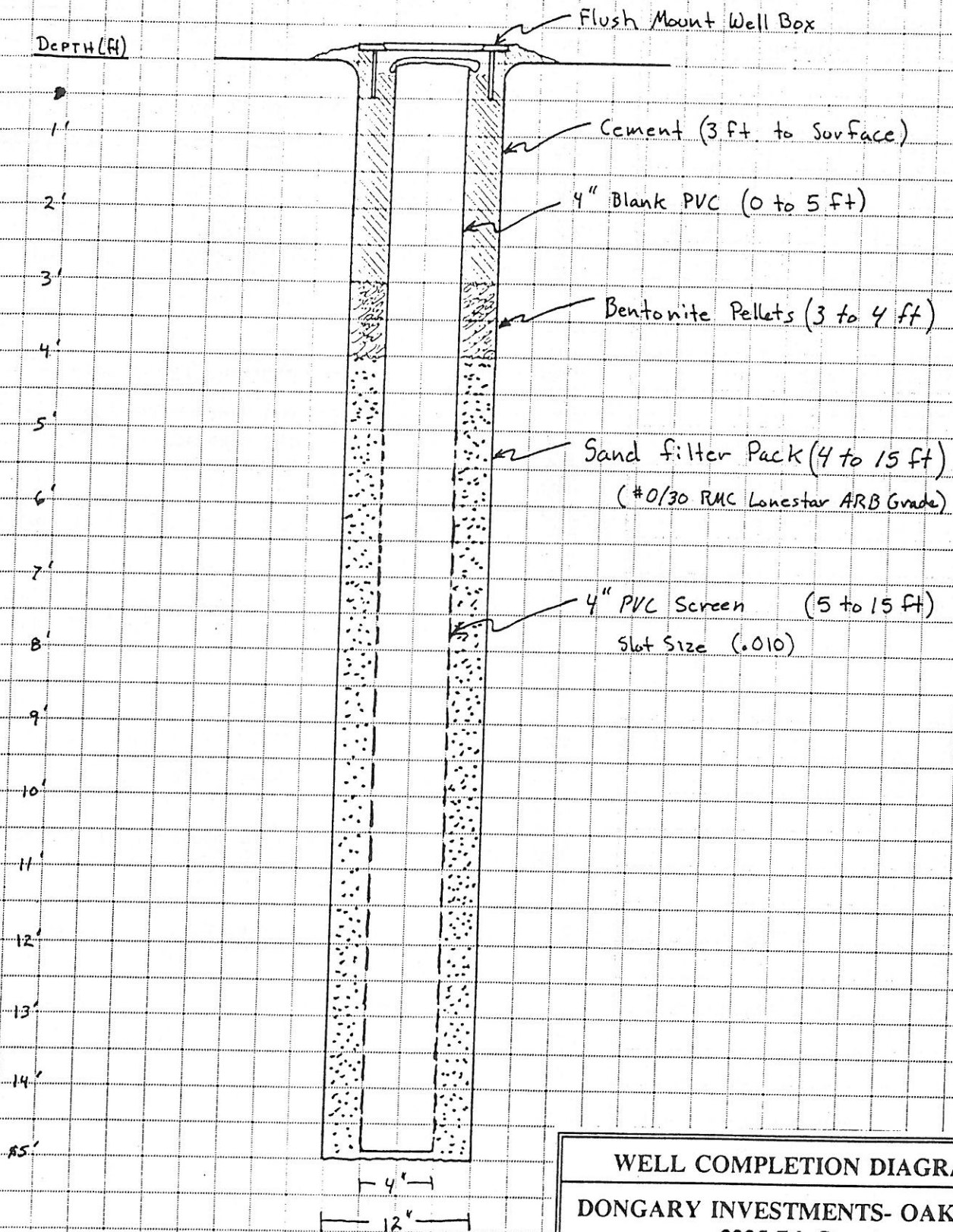

Three wells (MW-1, MW-2, MW-3)
all completed to 15 feet.

WELL COMPLETION DIAGRAM	
DONGARY INVESTMENTS- OAKLAND 2225 7th Street Oakland, CA. 94607	
RAMCON Job #467004	Date: 03-18-93
Scale: 1" = 20'	Plot: 10'

DONGARY INVEST OAKLAND
 RAMCON Job #476004
 Logged by: J. Auchterlonie

BORE HOLE #: BH- 13. (MW-3)
 LOCATION: 15' S & 137' E
 DRILLED BY: TABER DRILLING

DATE STARTED: 12-16-92 DATE COMPLETED: 12-16-92
 APPROXIMATE SURFACE ELEVATION: 10 feet above sea level.

Boring locations measured perpendicular from the N.E. corner of the Sea Land Car Wash.

DEPTH	SAMPLE			USCS CLASS	LITH LOG	SOIL DESCRIPTIONS
	SAMPLE NUMBER	TYPE	INTERVAL			
			FROM & TO			
0				GC		ASPHALT & GRAVEL BASE
4	BH13-4'	CC	Core from 4 to 9 ft Recover 36"	SC		CLAYEY SAND. Light Green. Loose. Moist. medium to coarse grained, poorly sorted. No Odor or Stain.
	BH13-5'	CC		CH		CLAY. Green. stiff. moist. No Diesel Odor or Stain.
	BH13-7'	CC		SW		SAND. Light Brown. dry to moist. loose, well sorted fine to medium grained. No Diesel Odor. Appears water saturated at <u>6 feet.</u>
8			LOST CORE 2 feet			
12				CL/SC		? SAND/CLAY contact estimated CLAY. Green & Black. soft. plastic. moist to wet. No Diesel Odor or Stain. CLAY has minor amounts of interbedded SAND. and CLAYEY SAND.
16						TOTAL DEPTH 15 feet.
20						<p>BORING CONVERTED TO 4" GROUNDWATER MONITOR WELL.</p> <p>SCREEN from 5 to 15 feet BLANK from 0 to 5 feet BENTONITE from 3 to 4 feet CEMENT from 0 to 3 feet</p> <p>Attempt to recover hydropunch water from 12 to 14 failed.</p>
24						

DONGARY INVEST OAKLAND
 RAMCON Job #476004
 Logged by: J. Auchterlonie

BORE HOLE #: BH- 15. (MW-1)
 LOCATION: 115' S & 10' W
 DRILLED BY: TABER DRILLING

DATE STARTED: 12-16-92 DATE COMPLETED: 12-16-92
 APPROXIMATE SURFACE ELEVATION: 10 feet above sea level.

Boring locations measured perpendicular from the N.E. corner of the Sea Land Car Wash.

DEPTH	SAMPLE		USCS CLASS	LITH LOG	SOIL DESCRIPTIONS	
	SAMPLE NUMBER	TYPE				INTERVAL
						FROM & TO
0	BH15-5'	CC		GC	ASPHALT & GRAVEL BASE	
				SC	CLAYEY SAND & GRAVEL. Rusty Brown. Loose, moist, medium to coarse grained. Poorly sorted. No Odor or Stain.	
4			Core from 4 to 9 ft Recover 24"	SW		SAND. Light Brown, dry to moist, loose, well sorted fine to medium grained. No Diesel Odor. Dry @ 4 ft. Appears water saturated at 5 ft.
			LOST CORE			
8			3 feet			
12			CL/SC	? SAND/CLAY contact estimated CLAY. Green & Black, soft, plastic, moist to wet, No Diesel Odor or Stain. CLAY has minor amounts of interbedded SAND, and CLAYEY SAND.		
16	TOTAL DEPTH 15 feet.					
20	BORING CONVERTED TO 4" GROUNDWATER MONITOR WELL. SCREEN from 5 to 15 feet BLANK from 0 to 5 feet BENTONITE from 3 to 4 feet SAND filter pack from 4 to 15 feet CEMENT from 0 to 3 feet					
24						

DONGARY INVEST OAKLAND
 RAMCON Job #476004
 Logged by: J. Auchterlonie

BORE HOLE #: BH- 16. (MW-2)
 LOCATION: 55' N & 180' W
 DRILLED BY: TABER DRILLING

DATE STARTED: 12-16-92 DATE COMPLETED: 12-16-92
 APPROXIMATE SURFACE ELEVATION: 10 feet above sea level.

Boring locations measured perpendicular from the N.E. corner of the Sea Land Car Wash.

DEPTH	SAMPLE			USCS CLASS	LITH LOG	SOIL DESCRIPTIONS
	SAMPLE NUMBER	TYPE	INTERVAL			
			FROM & TO			
0				GC		ASPHALT & GRAVEL BASE
				SC		CLAYEY SAND, Dark Greenish Gray, Soft. moist, medium to coarse grained. Poorly sorted. No Odor or Stain.
4			NO SAMPLES TAKEN See BH9 for core & samples.	SW		SAND, Greenish Gray, loose, well sorted, <5% Clay, fine to medium grained, No Diesel Odor. Dry @ 4 ft. Appears water saturated at 5 ft.
8						? SAND/CLAY contact estimated
12				CL/SC		CLAY, Green & Black, soft, plastic, moist to wet. No Diesel Odor or Stain. CLAY has minor amounts of interbedded SAND, and CLAYEY SAND.
16	TOTAL DEPTH 15 feet.					
20	BORING CONVERTED TO 4" GROUNDWATER MONITOR WELL. SCREEN from 5 to 15 feet BLANK from 0 to 5 feet BENTONITE from 3 to 4 feet SAND filter pack from 4 to 15 feet CEMENT from 0 to 3 feet					
24	BH16 is located 10 feet West of BH9. Since BH9 was cored and sampled, no samples were collected from BH16.					

Port of Oakland-2277 Seventh St.

Bore Hole MW-1

Date 5/16/94
Drilling Method HS Auger
Sampling Method 18" Split spoon
Surface Elevation 14.38
Recorded By JC Borrego
Registered Geologist _____

Well As-Built

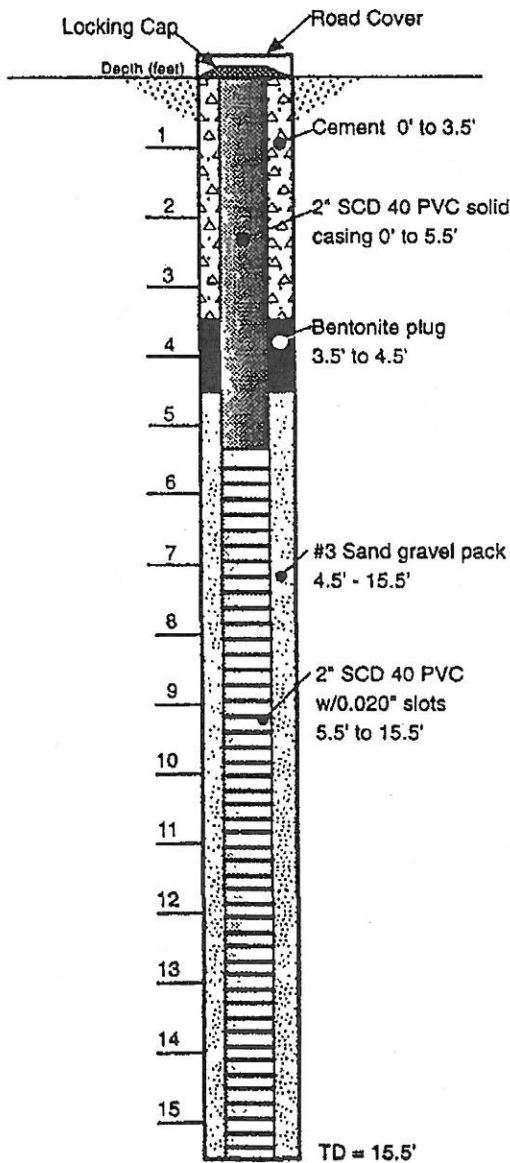

Lithologic Descriptions/Remarks

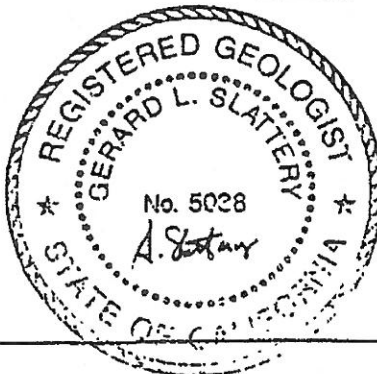
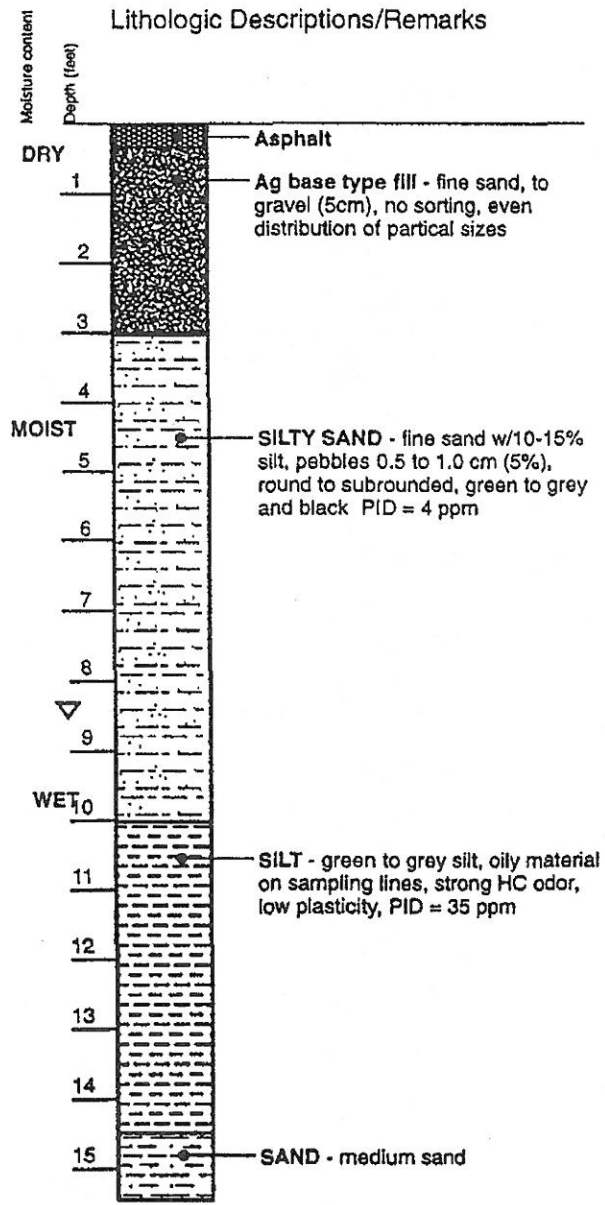

96-209 MW-1 11/10/94 DY

Port of Oakland-2277 Seventh St.
Bore Hole MW-2

Date 5/16/94
 Drilling Method HS Auger
 Sampling Method 18" Split spoon
 Surface Elevation 14.38
 Recorded By JC Borrego
 Registered Geologist _____

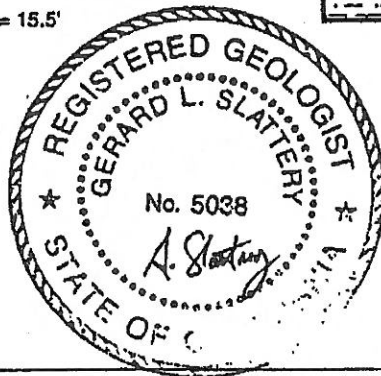
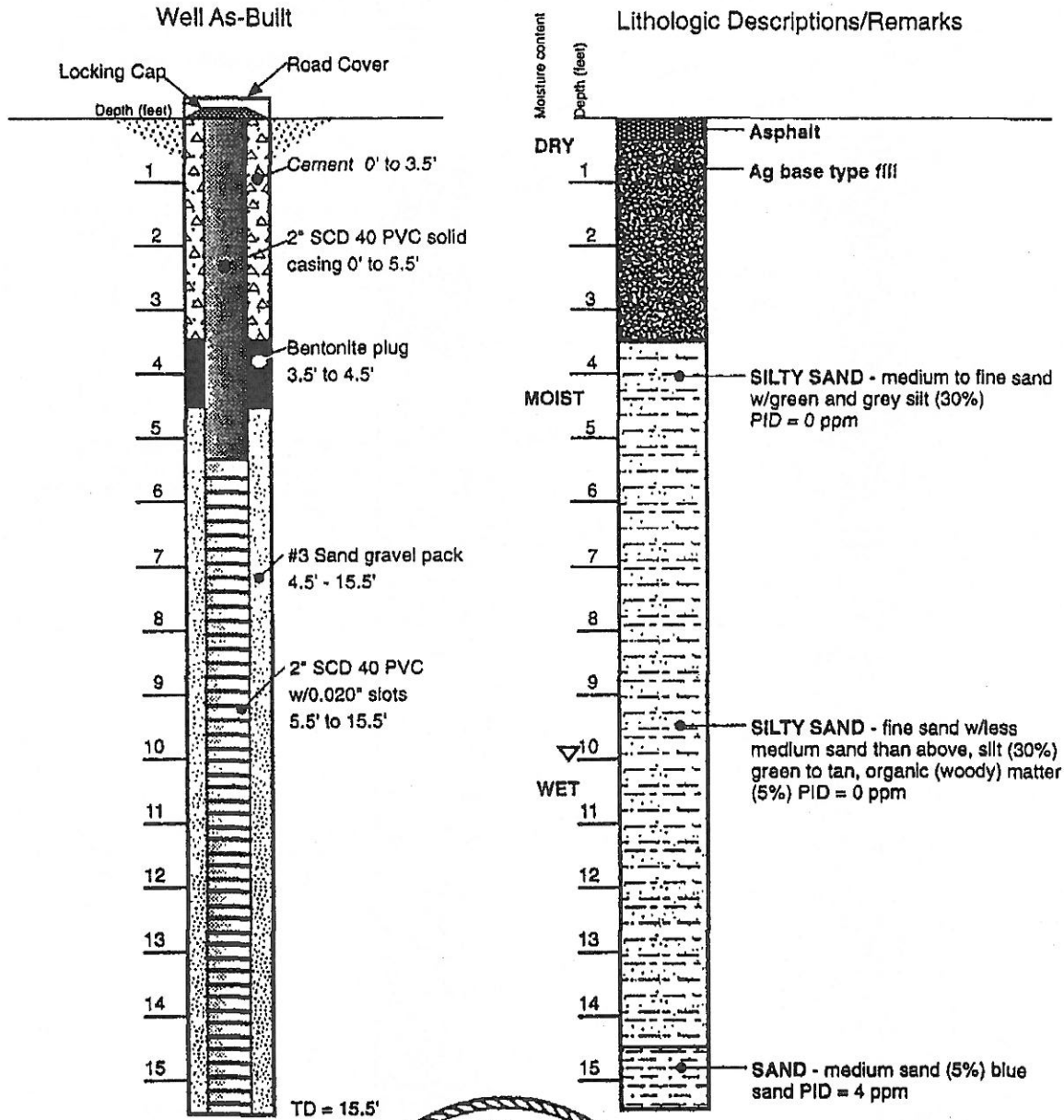

96-209 MW-2 9/27/94 DY RH

Port of Oakland-2277 Seventh St.

Bore Hole MW-3

Date 5/16/94
Drilling Method HS Auger
Sampling Method 18" Split spoon
Surface Elevation 14.24
Recorded By JC Borrego
Registered Geologist _____

Well As-Built

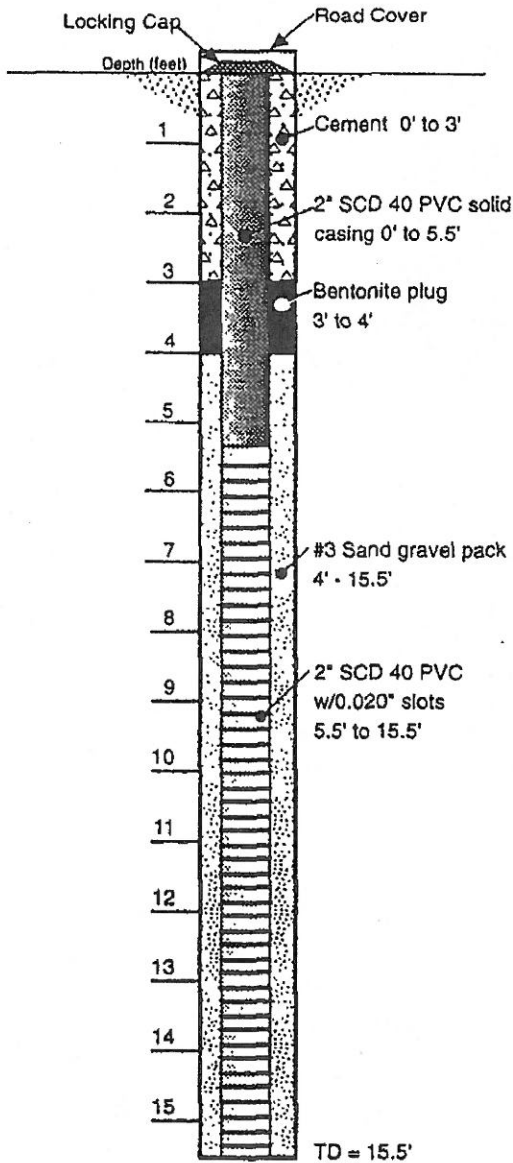

Lithologic Descriptions/Remarks

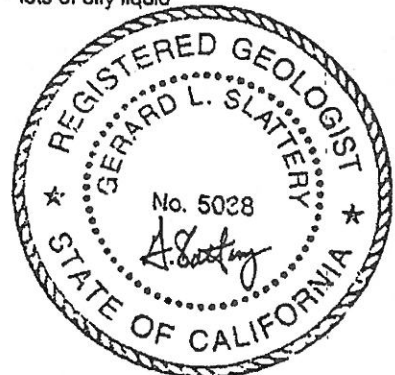
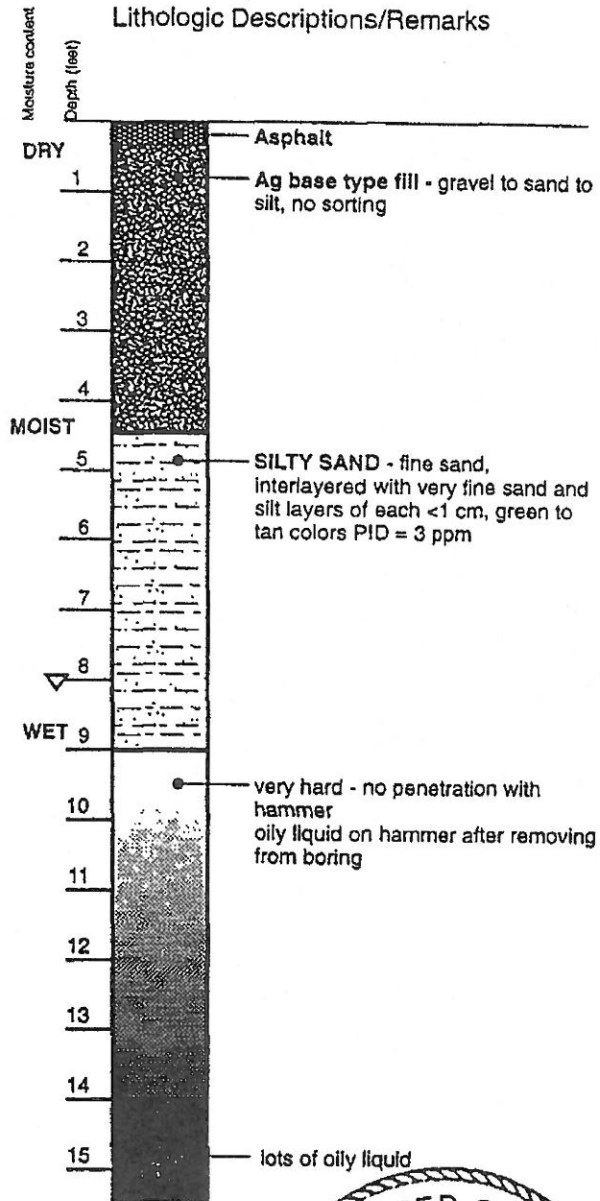

Urbe & Associates



ALISTO ENGINEERING GROUP
WALNUT CREEK, CALIFORNIA

LOG OF BORING MW-4

Page 1 of 1

SEE SITE PLAN

ALISTO PROJECT NO: 10-270-01 DATE DRILLED: 08/25/95
 CLIENT: Port of Oakland
 LOCATION: 2277 E. 7th Street, Oakland, CA.
 DRILLING METHOD: Hollow-stem auger (7 3/4"); 2" split-spoon sampler
 DRILLING COMPANY: Mitchell Drilling Envtl. CASING ELEVATION: 13.15 'MSL
 LOGGED BY: Chris Reinheimer APPROVED BY: Al Sevilla

BLOWS/6 IN.	PTD VALUES	WELL DIAGRAM	DEPTH feet	SAMPLES	GRAPHIC LOG	SOIL CLASS	GEOLOGIC DESCRIPTION
							3" asphalt; 2.2' roadbase
7,7,7	0		5			SC	clayey SAND: mottled dark brown and medium tan; damp, medium dense; clayey blebs to approximately 10%; organics to approximately 5%.
8,8,11	0		10			SM	silty SAND: dark gray green, moist to wet, medium dense; silty clayey shell fragments to approximately 2%.
4,8,11	NM		15			CL	CLAY: dark gray black, moist to wet, very stiff; organics to approximately 20%; medium-grained sand to approximately 2%.
8,8,11	NM		20				Same: at 10 feet.
			25				Stabilized water level measured on September 8, 1995.
			30				



LOG OF BORING MW-5

SEE SITE PLAN

ALISTO PROJECT NO: 10-270-01

DATE DRILLED: 08/25/95

CLIENT: Port of Oakland

LOCATION: 2277 E. 7th Street, Oakland, CA.

DRILLING METHOD: Hollow-stem auger (7 3/4"); 2" split-spoon sampler

DRILLING COMPANY: Mitchell Drilling Envtl.

CASING ELEVATION: 13.49 'MSL

LOGGED BY: Chris Reinheimer

APPROVED BY: Al Sevilla

BLOWS/8 IN.	PTD VALUES	WELL DIAGRAM	DEPTH feet	SAMPLES	GRAPHIC LOG	SOIL CLASS	GEOLOGIC DESCRIPTION
							3" asphalt; 2.2' roadbase
8,8,12	3		5			SM	SAND: medium brown, damp, medium dense; clayey blebs to approximately 2%; shell fragments to approximately 2%.
11,11,18	1		10			SC	clayey SAND: dark gray black, wet, very stiff; organics to approximately 10%.
8,8,12	0		15				Same: at 15 feet.
8,8,4	0		20			SM	silty SAND: gray green mottled with Fe oxide stain, wet to saturated, medium dense; shells to approximately 5%; sand moderately well graded.
							Stabilized water level measured on September 8, 1995.



ALISTO ENGINEERING GROUP
WALNUT CREEK, CALIFORNIA

LOG OF BORING MW-7

Page 1 of 1

SEE SITE PLAN

ALISTO PROJECT NO: 10-270-01

DATE DRILLED: 08/25/95

CLIENT: Port of Oakland

LOCATION: 2277 E. 7th Street, Oakland, CA.

DRILLING METHOD: Hollow-stem auger (7 3/4"); 2" split-spoon sampler

DRILLING COMPANY: Mitchell Drilling Envtl.

CASING ELEVATION: 14.35 'MSL

LOGGED BY: C. Ladd

APPROVED BY: Al Sevilla

BLOMS/6 IN.	PID VALUES	WELL DIAGRAM	DEPTH feet	SAMPLES	GRAPHIC LOG	SOIL CLASS	GEOLOGIC DESCRIPTION
		<p>2" Sch. 40 PVC</p> <p>Neat Cement Bentonite Seal</p> <p>0.010" Slotted PVC Screen</p> <p>#2/12 Lonestar Sand</p>	5			SM	4" asphalt
10,12,15	0		10			SC	SAND: gray, damp, medium dense; fine- to medium-grained sand; clayey blebs to 5%.
12,12,17	0		15			SP	sandy CLAY: brown to black gray, moist, very stiff; organics as blebs to approximately 2%.
11,11,17	0		20				SAND: black gray, wet, medium dense; fine- to medium-grained sand; shell fragments present to 3%.
12,14,20			20				Same: olive brown, wet, dense; fine- to medium-grained sand.
			25				Stablized water level measured on September 8, 1995.
			30				



ALISTO ENGINEERING GROUP
WALNUT CREEK, CALIFORNIA

LOG OF BORING MW-8

Page 1 of 1

SEE SITE PLAN

ALISTO PROJECT NO: 10-270-01

DATE DRILLED: 08/25/95

CLIENT: Port of Oakland

LOCATION: 2277 E. 7th Street, Oakland, CA.

DRILLING METHOD: Hollow-stem auger (7 3/4"); 2" split-spoon sampler

DRILLING COMPANY: Mitchell Drilling Envtl.

CASING ELEVATION: 12.94 'MSL

LOGGED BY: C. Ladd

APPROVED BY: Al Sevilla

BLOWS/6 IN.	PTD VALUES	WELL DIAGRAM	DEPTH feet	SAMPLES	GRAPHIC LOG	SOIL CLASS	GEOLOGIC DESCRIPTION
							4" asphalt
8,9,11	8		5			CL	gravelly CLAY: mottled greenish gray and olive brown, damp, very stiff; subrounded to angular gravel to 1"-diameter.
14,28,36	4		10			GW	sandy GRAVEL: grayish brown, wet, very dense; angular to subrounded gravels to 2"-diameter.
19,21,30	0		15			SW	gravelly SAND: gray, wet, very dense; subrounded gravel to 2"-diameter.
12,15,17	0		20			SP	SAND: blue gray, saturated, dense; medium-grained sand; well sorted; 1/4"-diameter subrounded gravel to approximately 1%.
							Stablized water level measured on September 8, 1995.

LOCATION 2277 7TH STREET OAKLAND BORING DEPTH 20.75' BORING NO. MW-8A
 SURFACE ELEVATION NOT AVAILABLE DATE BEGAN 2 OCT 2001 SHEET 1 OF 2
 DRILLING METHOD 6 1/2" HOLLOW STEM AUGER DATE FINISHED 2 OCT 2001
 SAMPLING METHOD CA, MODIFIED SPLIT SPOON LOGGED BY J. ANDERSON

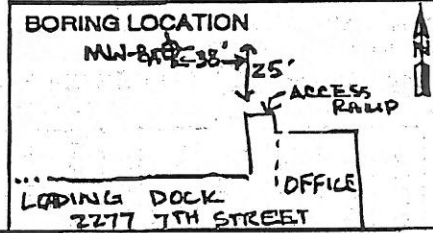

EDITED BY _____
 CHECKED BY _____

DEPTH (FEET)	WELL CONSTRUCTION	WATER LEVEL	PID (PPM) B-zones/stem/sample	FLOW COUNTS (BLGWS/FOOT)	SAMPLE TYPE	U.S.C.S.	LITHOLOGY	DESCRIPTION
0.0	CEMENT						ASPHALT	
0.0 - 0.5			0.02/10.0		GRAB	SW		OLIVE BROWN, WELL GRADED SAND WITH GRAVEL, (SW), (2.574/4), MOIST, LOOSE, 25-55% FINE TO COARSE SAND, 35-45% FINE TO COARSE GRAVEL TO 1.5", SAND AND GRAVEL ANGULAR, 0-5% FINES.
0.5 - 1.0			110.0		GRAB	GW		01' VERY DARK GRAY, WELL GRADED GRAVEL WITH SAND, (GW), (573/1), 60-70% GRAVEL, 25-35% FINE TO COARSE SAND, 0-5% FINES, GRAVEL TO 2.5" CONSISTING OF CHEST AND GRANITE ROCK.
1.0 - 1.2			11.2		GRAB	SW		02' BLACK, WELL GRADED SAND WITH GRAVEL, (SW), (572.5/1), 50-60% FINE TO COARSE SAND, 20-30% FINE TO COARSE GRAVEL, 5-10% FINES, 5-10% WOOD FRAGMENTS, GRAVEL TO 2.5", CREOSOTE ODOR
1.2 - 1.5			45/45/101		GRAB	SC		HARD MATERIAL AT 2.5' (DRILLER STATES CONCRETE)
1.5 - 1.8			111.4		GRAB	SC		03' VERY DARK GRAY, CLAYEY SAND WITH GRAVEL, (SC), (2.573/1), 40-50% FINE TO MEDIUM SAND, 25-35% CLAY, 10-20% GRAVEL TO 1", 10-20% WOOD FRAGMENT, STRONG CREOSOTE ODOR.
1.8 - 2.0			110.1		GRAB	CH		04' OLIVE GRAY CLAYEY SAND, (SC), (574/1), 40-50% FINE TO MEDIUM SAND, 35-45% FAT CLAY, 5-10% SILT, SAND ANGULAR, CLAY MEDIUM TO HIGH PLASTICITY.
2.0 - 2.5			0.09/		GRAB	CH		04.5' MOTTLED DARK OLIVE GRAY, OLIVE & PALE YELLOW, SANDY FAT CLAY, (CH), (573/2, 574/4 & 577/3), SOFT TO FIRM, 60-70% FAT CLAY, 20-30% FINE SAND, 5-10% SILT, HIGH PLASTICITY, STRONG ODOR.
2.5 - 3.0			11.5		SPLIT SPOON			06' SAME AS ABOVE (S.A.A.)
3.0 - 3.5			2/4		SPLIT SPOON	SC		07' OLIVE, CLAYEY SAND, (SC), (574/3), FIRM, WET, 45-55% FINE TO MEDIUM SAND, 40-50% FAT CLAY, 5-10% SILT.
3.5 - 4.0			11.8		SPLIT SPOON	CH		LIGHT OLIVE GRAY
4.0 - 4.5			4/6/8		SPLIT SPOON	CH		08' MOTTLED OLIVE, GRAYISH GREEN & BLACK, SANDY FAT CLAY, (CH), (574/4, 576/2, 575/2 & 572.5/1), SOFT, MOIST, 50-60% FAT CLAY, 40-50% FINE SAND
4.5 - 5.0					SPLIT SPOON	CH		08.5' DARK GRAY, FAT CLAY, (CH), (574/1), MOIST, FIRM, MEDIUM PLASTICITY, 95-100% CLAY, 0-5% SAND.
5.0 - 10.0			11.0		GRAB	CH		: FROM THIS POINT ON CUTTINGS WERE AUGER MIXED.
10.0 - 11.0					GRAB	CH		010' DARK GREEN/KN GRAY, FAT CLAY, (CH), (1073/1), HIGH PLASTICITY.
11.0 - 12.0					GRAB	CH		012' BLACK (572.5/1).



PROJECT PORT OF OAKLAND
 PROJECT NO. CO-152.01

LOCATION 2277 7TH STREET OAKLAND BORING DEPTH 20.75'
 SURFACE ELEVATION NOT AVAILABLE DATE BEGAN 20 OCT 2001
 DRILLING METHOD 6 1/2" HOLLOW STEM AUGER DATE FINISHED 20 OCT 2001
 SAMPLING METHOD GRAB LOGGED BY J. ANDERSON

BORING NO. MW-8A
 SHEET 2 OF 2

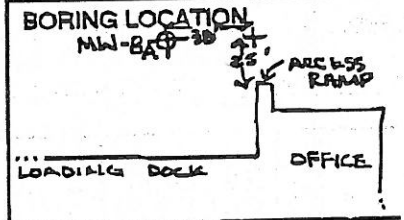

DEPTH (FEET)	WELL CONSTRUCTION	WATER LEVEL	PID (PPM) B-zones/samples	BLOW COUNTS (BLOWS/FOOT)	SAMPLE TYPE	U.S.C.S.	LITHOLOGY	DESCRIPTION
15.0	N# 12 Boul. 2mm x 5mm S					CH	FROM ABOVE: BLACK, FAT CLAY, (CH), (54Z.S/I), SOFT TO FIRM, MOIST, 95-100% FAT CLAY, 0-5% FINE SAND, HIGH PLASTICITY. SAND INCREASING / CLAY DECREASING.	
			N.D.	GRAB	SC	@ 17' DARK GREENISH GRAY, CLAYRY SAND, (SC), (), SOFT, SATURATED, 50-60% FINE TO MEDIUM SAND, 30-40% CLAY, 5-10% SILT.		
			N.D.	GRAB	SP	@ 19' OLIVE BROWN, POORLY GRADED SAND, (SP), (2.54A/4), FIRM SATURATED, 75-100% FINE TO MEDIUM SAND, 0-5% FINES.		
20.0							BOTTOM OF BORING AT 20.75'	
25.0								
30.0								



PROJECT PORT OF OAKLAND
 PROJECT NO. 00-152.01

PROJECT: Port of Oakland		Log of Well No. MW-9	
BORING LOCATION: 651 and 555 Maritime Street, Oakland, CA		GROUND SURFACE ELEVATION AND DATUM: not surveyed	
DRILLING CONTRACTOR: Gregg Drilling and Testing		DATE STARTED: 12/1/08	DATE FINISHED: 12/1/08
DRILLING METHOD: Hollow stem auger		TOTAL DEPTH (ft.): 25 ft.	SCREEN INTERVAL (ft.): 10 ft.
DRILLING EQUIPMENT: Marl M5T		DEPTH TO WATER: 17.0	COMPL.: ---
SAMPLING METHOD: California split spoon		LOGGED BY: A. Letcher	
HAMMER WEIGHT: ---		DROP: A. Atkinson	REG. NO. 3515

DEPTH (feet)	SAMPLES			OVM READING	DESCRIPTION NAME (USCS): color, moist, % by weight, plast. density, structure, cementation, react., w/HCl, geo. inter.	WELL CONSTRUCTION DETAILS AND/OR DRILLING REMARKS
	SAMPLE NO.	SAMPLE	BLOWS/FOOT			
1					Asphalt	<p>Hand augered to 5 ft</p> <p>Traffic-rated EMCO Wheaton flush-mounted well box</p> <p>Basalite type II/V neat cement grout</p> <p>2" diameter Schedule 40 PVC blank casing</p> <p>3/8" chip Bentonite hole-plug</p> <p>Lapis Lustre #2/16 filter pack sand</p>
2						
3						
4						
5						
6	MW-9@6			0	SILTY GRAVEL with SAND (GM), reddish black (2.5YR 2.5/1), moist, 50% fine gravel, 25% fine to coarse sand, 25% medium plasticity fines	
7						
8						
9						
10						
11	MW-9@11			511		
12						
13						
14						
15						

LOG OF BORING 2007 PORT OF OAKLAND GINT.GPJ ENV AMERICA 2007.GDT 12/4/08

LOG OF BORING 2007



DEPTH (feet)	SAMPLES			OVM READING	DESCRIPTION NAME (USCS): color, moist, % by weight, plast. density, structure, cementation, react., w/HCl, geo. inter.	WELL CONSTRUCTION DETAILS AND/OR DRILLING REMARKS
	SAMPLE NO.	SAMPLE	BLOWS/ FOOT			
16	MW-9@16			0	LEAN CLAY with SAND (CL) (Cont.)	<p>First water at 17"</p> <p>2" diameter Schedule 40 PVC 0.010" machine slotted screen</p> <p>Lapis Lustre #2/16 filter pack sand</p>
17						
18						
19						
20						
21						
22						
23						
24					POORLY GRADED SAND with SILT (SP-SM), dark greenish gray (GLEY 1 4/10Y), moist, 90% fine to medium sand, 10% non-plastic fines	
25				0		

Bottom of boring at 25 ft

LOG OF BORING 2007 PORT OF OAKLAND GINT.GPJ ENV AMERICA 2007.GDT 12/4/08



PROJECT: Port of Oakland		Log of Well No. MW-10	
BORING LOCATION: 651 and 555 Maritime Street, Oakland, CA		GROUND SURFACE ELEVATION AND DATUM: not measured	
DRILLING CONTRACTOR: Gregg Drilling and Testing		DATE STARTED: 12/1/08	DATE FINISHED: 12/1/08
DRILLING METHOD: Hollow stem auger		TOTAL DEPTH (ft.): 25 ft.	SCREEN INTERVAL (ft.): 10 ft.
DRILLING EQUIPMENT: Marl M5T		DEPTH TO WATER: 17.5	COMPL.: ---
SAMPLING METHOD: California split spoon		LOGGED BY: A. Letcher	
HAMMER WEIGHT: ---		DROP: A. Atkinson	REG. NO. 3515

DEPTH (feet)	SAMPLES			OVM READING	DESCRIPTION NAME (USCS): color, moist, % by weight, plast. density, structure, cementation, react., w/HCl, geo. inter.	WELL CONSTRUCTION DETAILS AND/OR DRILLING REMARKS
	SAMPLE NO.	SAMPLE	BLOWS/FOOT			
1					Asphalt	
2						
3						
4						
5						
6	MW-10@6			0	POORLY GRADED SAND with SILT and GRAVEL (SP-SM), brown (10YR4/3), moist, 60% fine to coarse sand, 30% fine gravel, 10% non-plastic fines	
7						
8						
9						
10						
11	MW-10@11			0		
12						
13						
14						
15						

LOG OF BORING 2007 PORT OF OAKLAND GINT.GPJ ENV AMERICA 2007.GDT 12/4/08

LOG OF BORING 2007



DEPTH (feet)	SAMPLES			OVM READING	DESCRIPTION NAME (USCS): color, moist, % by weight, plast. density, structure, cementation, react., w/HCl, geo. inter.	WELL CONSTRUCTION DETAILS AND/OR DRILLING REMARKS
	SAMPLE NO.	SAMPLE	BLOWS/ FOOT			
16	MW-10@16				(CL) LEAN CLAY with SAND (CL), black (10YR2/1), moist, 90% clay, 10% fine sand, high plasticity	<p>First water at 17.5 ft</p> <p>2" diameter Schedule 40 PVC 0.010" machine slotted screen</p> <p>Lapis Lustre #2/16 filter pack sand</p>
17						
18						
19						
20						
21	MW-10@21				POORLY GRADED SAND with SILT (SP-SM), black (10YR2/1), wet, 90% fine to medium sand, 10% non-plastic fines	
22						
23						
24						
25	MW-10@25					

Bottom of boring at 25 ft

PROJECT: Port of Oakland		Log of Well No. MW-11	
BORING LOCATION: 651 and 555 Maritime Street, Oakland, CA		GROUND SURFACE ELEVATION AND DATUM: not measured	
DRILLING CONTRACTOR: Gregg Drilling and Testing		DATE STARTED: 12/1/08	DATE FINISHED: 12/1/08
DRILLING METHOD: Hollow stem auger		TOTAL DEPTH (ft.): 25 ft.	SCREEN INTERVAL (ft.): 10 ft
DRILLING EQUIPMENT: Marl M5T		DEPTH TO WATER: 17.0	COMPL.: ---
SAMPLING METHOD: California split spoon		LOGGED BY: A. Letcher	
HAMMER WEIGHT: ---	DROP:	REVIEWED BY: A. Atkinson	REG. NO. 3515

DEPTH (feet)	SAMPLES			OVM READING	DESCRIPTION NAME (USCS): color, moist, % by weight, plast. density, structure, cementation, react., w/HCl, geo. inter.	WELL CONSTRUCTION DETAILS AND/OR DRILLING REMARKS
	SAMPLE NO.	SAMPLE	BLOWS/FOOT			
1					Asphalt	<p>Hand augered to 5 ft.</p> <p>Traffic-rated EMCO Wheaton flush-mounted well box</p> <p>Basalite type II/V neat cement grout</p> <p>2" diameter Schedule 40 PVC blank casing</p> <p>3/8" chip Bentonite hole-plug</p> <p>#2/16 Lapis Lustre filter pack sand</p>
2						
3						
4						
5						
6	MW-10@6			1.9	SILTY SAND (SM), dark greyish brown (10YR4/2), moist, 80% fine to medium sand, 20% non-plastic fines	
7						
8						
9						
10						
11	MW-10@11			0		
12						
13					SANDY LEAN CLAY (CL), dark greenish gray (GLE Y1 4/10Y), moist, 90% fine to medium sand, 10% non-plastic fines	
14						
15						

LOG OF BORING 2007 PORT OF OAKLAND GINT.GPJ ENV AMERICA 2007.GDT 12/4/08

LOG OF BORING 2007



DEPTH (feet)	SAMPLES			OVM READING	DESCRIPTION NAME (USCS): color, moist, % by weight, plast. density, structure, cementation, react., w/HCl, geo. inter.	WELL CONSTRUCTION DETAILS AND/OR DRILLING REMARKS
	SAMPLE NO.	SAMPLE	BLOWS/ FOOT			
16	MW-10@16			0	LEAN CLAY (CL), black (10YR2/1), moist, 85% clay, 15% fine to medium sand, high plasticity HYRDOCARBON ODOR	<p>First water at 17.5 ft</p> <p>2" diameter Schedule 40 PVC 0.010" machine slotted screen</p> <p>Lapis Lustre #2/16 filter pack sand</p>
17					SILTY SAND (SM), black (10YR2/1), moist, 70% fine to medium sand, 30% non-plastic fines	
18						
19						
20						
21	MW-10@21			0		
22						
23						
24					↓ (SW)(Cont.) wet	
25	MW-10@25			0		

Bottom of boring at 25 ft

LOG OF BORING 2007 PORT OF OAKLAND GINT.GPJ ENV AMERICA 2007.GDT 12/4/08



PROJECT: Port of Oakland		Log of Well No. MW-12	
BORING LOCATION: 651 and 555 Maritime Street, Oakland, CA		GROUND SURFACE ELEVATION AND DATUM: not measured	
DRILLING CONTRACTOR: Gregg Drilling and Testing		DATE STARTED: 12/2/08	DATE FINISHED: 12/2/08
DRILLING METHOD: Hollow stem auger		TOTAL DEPTH (ft.): 25 ft.	SCREEN INTERVAL (ft.): 10 ft
DRILLING EQUIPMENT: Marl M5T		DEPTH TO WATER: 17.0	COMPL.: ---
SAMPLING METHOD: California split spoon		LOGGED BY: A. Letcher	
HAMMER WEIGHT: ---		DROP: A. Atkinson	REG. NO. 3515

DEPTH (feet)	SAMPLES		OVM READING	DESCRIPTION NAME (USCS): color, moist, % by weight, plast. density, structure, cementation, react., w/HCl, geo. inter.	WELL CONSTRUCTION DETAILS AND/OR DRILLING REMARKS
	SAMPLE NO.	SAMPLE BLOWS/FOOT			
1				Asphalt	
2					
3					
4					
5					
6	MW-10@6		0.8	(SW-SM) WELL GRADED SAND with SILT and GRAVEL (SW-SM), (7.5YR3/2), 70% fine to coarse sand, 20% rounded gravel, 10% non-plastic fines	
7					
8					
9					
10	MW-10@11		45		
11					
12					
13					
14				WELL GRADED GRAVEL with CLAY, (GLEY 2 2.5/10BG), wet, 70% coarse gravel, 10% fine sand, 20% low plasticity fines	
15					

LOG OF BORING 2007 PORT OF OAKLAND GINT.GPJ ENV AMERICA 2007.GDT 12/4/08

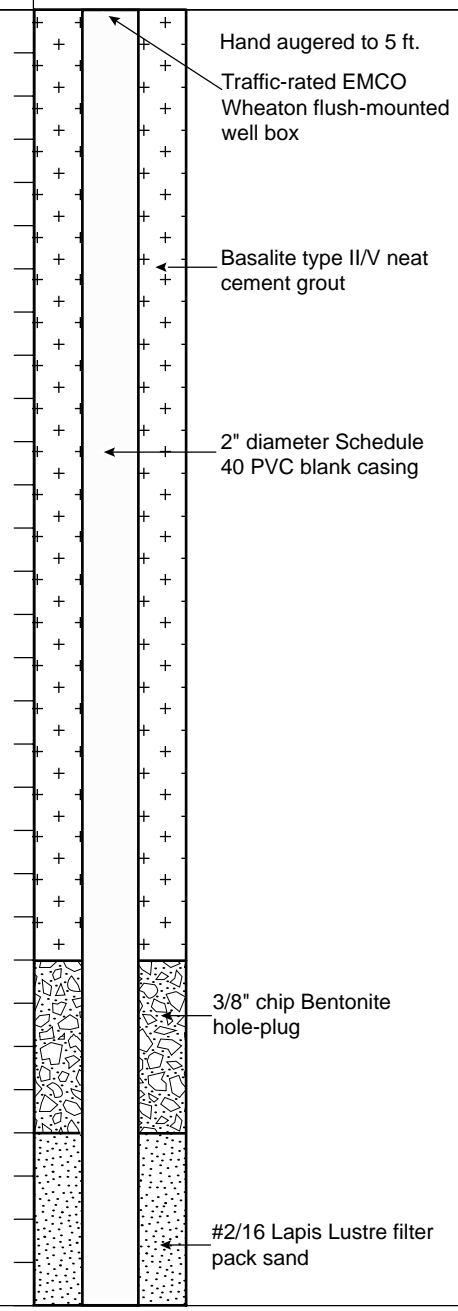

LOG OF BORING 2007



DEPTH (feet)	SAMPLES			OVM READING	DESCRIPTION NAME (USCS): color, moist, % by weight, plast. density, structure, cementation, react., w/HCl, geo. inter.	WELL CONSTRUCTION DETAILS AND/OR DRILLING REMARKS
	SAMPLE NO.	SAMPLE	BLOWS/ FOOT			
16	MW-10@16			10	(GC)(Cont.) SILT with GRAVEL (GLEY 2.2.5/10BG), wet, 80% fines, 15% fine gravel, 5% fine sand, non-plastic FREE PRODUCT IN SAMPLE	<p>First water at 17.5 ft</p> <p>2" diameter Schedule 40 PVC 0.010" machine slotted screen</p> <p>Lapis Lustre #2/16 filter pack sand</p>
21	MW-10@21			2 5	(SW-SM) WELL GRADED SAND with SILT and GRAVEL (SW-SM), (2.5YR2.5/2), wet, 75% fine to medium sand, 15% fine gravel, 10% non-plastic fines FREE PRODUCT IN SAMPLE	
25	MW-10@25			0.5	(SP) POORLY GRADED SAND (SP), (GLEY 14/104), moist, 95% fine to medium sand, 5% non-plastic fines	

Bottom of boring at 25 ft

Boring location: See Site Plan, Figure 2
 Date started: 4/28/04 Date finished: 4/28/04
 Drilling method: 11-inch Hollow-stem auger
 Hammer weight/drop: --- Hammer type: ---

Sampler: split spoon

DEPTH (feet)	SAMPLES				OVN (ppm)	LITHOLOGY	MATERIAL DESCRIPTION	WELL COMPLETION INFORMATION	
	Sample Number	Sample	Blow Count	Recovery (feet)					
1						SM	SILTY SAND (SM) dark brown, dry, sub-rounded, moderately graded, no odor, fill	<p>Flush mounted completion Sch 40 4" PVC, blank from 0 to 5 feet Grout From 2 To 3 Feet Bentonite From 3 To 4 Feet</p>	<p>Sch 40 4" PVC 0.050" Vee wire screened casing from 5 to 15 feet Pea gravel from 4 to 18 feet</p>
2									
3									
4									
5									
6	RW-1-5.0					CL	CLAY (CL) moist, plastic, stiff, strong odor, 100 percent fines	<p>Sch 40 4" PVC 0.050" Vee wire screened casing from 5 to 15 feet Pea gravel from 4 to 18 feet</p>	<p>Sch 40 4" PVC, blank from 15 to 18 feet</p>
7									
8									
9									
10									
11						ML	SILT with SAND (ML) blue-green, wet, moderately graded, strong odor, 15 percent sand, 85 percent fines	<p>Sch 40 4" PVC, blank from 15 to 18 feet</p>	<p>Sch 40 4" PVC, blank from 15 to 18 feet</p>
12									
13									
14									
15							with sand		
16	RW-1-15.0								
17									
18									
19									
20									
21									
22									
23									
24									
25									
26									
27									
28									
29									
30									

Boring terminated at 18 feet.

TEST ENVIRONMENTAL WELL REV1 400001.GPJ T&R.GDT 7/13/05

PROJECT: HARBOR FACILITY CENTER
PORT OF OAKLAND
Oakland, California

Log of Recovery Well RW-2
PAGE 1 OF 1

Boring location: See Site Plan, Figure 2

Logged by: G. Johnson

Date started: 4/28/04

Date finished: 4/28/04

Drilled By: Gregg

Drilling method: 11-inch Hollow-stem auger

Hammer weight/drop: —

Hammer type: ---

Sampler: split spoon

DEPTH (feet)	SAMPLES				OVM (ppm)	LITHOLOGY	MATERIAL DESCRIPTION	WELL COMPLETION INFORMATION	
	Sample Number	Sample	Blow Count	Recovery (feet)					
1						SM	SILTY SAND/GRAVEL (SM) dark brown, moist, subrounded, moderately graded, no odor		Flush mounted completion
2						SM			Sch 40 4" PVC, blank from 0 to 8 feet
3						SM			Grout From 3 To 5 Feet
4						SM			
5						SP	SAND (SP) light brown, moist, subrounded, poorly graded, no odor		Bentonite From 5 To 7 Feet
6	RW-2-5.0					SP			
7						SP			
8						GP	GRAVEL (GP) gray, black and white, wet, angular, weak odor		Sch 40 4" PVC 0.050" Vee wire screened casing from 8 to 18 feet
9						GP			
10						GP			
11	RW-2-10.0					GP			
12						GP			
13						ML	SILT with SAND (ML) wet, moderately graded, strong odor, 15 percent sand, 85 percent fines		Pea gravel from 7 to 21 feet
14						ML			
15						ML			
16	RW-2-15.0					ML			
17						CL	CLAY (CL) black, soft, moist, strong odor		Sch 40 4" PVC, blank from 18 to 21 feet
18						CL			
19						CL			
20						CL			
21						CL			
22									
23									
24									
25									
26									
27									
28									
29									
30									

Boring terminated at 21.5 feet.

Treadwell & Rollo
Project No.: 4000.01 Figure: A-2

TEST ENVIRONMENTAL WELL REV1_400001.GPJ T&R.GDT 7/13/05

Boring location: See Site Plan, Figure 2
 Date started: 4/26/04 Date finished: 4/28/04
 Drilling method: 11-inch Hollow-stem auger
 Hammer weight/drop: --- Hammer type: ---
 Sampler: split spoon

DEPTH (feet)	SAMPLES				OVM (ppm)	LITHOLOGY	MATERIAL DESCRIPTION	WELL COMPLETION INFORMATION
	Sample Number	Sample	Blow Count	Recovery (feet)				
1						GRAVELLY SAND (SP) brown, dry, rounded, moderately graded, no odor, 25 percent gravel, 65 percent sand, 10 percent fines	Flush mounted completion Sch 40 4" PVC, blank from 0 to 8 feet	
2								
3								
4								
5								
6	RW-3-5.0	o				SAND (SP) gray-brown, dry, rounded, no odor	Grout From 3 To 5 Feet Bentonite From 5 To 7 Feet	
7								
8								
9						SILTY GRAVEL (GM) blue-gray, wet, moderate odor, organic matter, mostly silt with some large gravel obstruction at about 10 feet, very dense area, possible concrete debris	Sch 40 4" PVC 0.050" Vee wire screened casing from 8 to 18 feet	
10								
11	RW-3-10.0					SILT with SAND (ML) black to blue-green, wet, moderately graded, strong odor, 15 percent sand, 85 percent fines, black sand at 15 feet staining to 16 feet SILT (ML) blue-green, wet, moderately graded, strong odor, 5 percent gravel, 85 percent sand, 10 percent fines shells at 20.5 feet	Pea gravel from 7 to 21 feet Sch 40 4" PVC, blank from 18 to 21 feet	
12								
13								
14								
15								
16	RW-3-15.0					SILT (ML) blue-green, wet, moderately graded, strong odor, 5 percent gravel, 85 percent sand, 10 percent fines shells at 20.5 feet		
17								
18								
19								
20								
21	RW-3-20.0	o						
22								
23								
24								
25								
26								
27								
28								
29								
30								

TEST ENVIRONMENTAL WELL-REV1 400001.GPJ T&R.GDT 7/13/05

Boring terminated at 21.5 feet.

PROJECT:

HARBOR FACILITY CENTER
PORT OF OAKLAND
Oakland, California

Log of Recovery Well RW-4

PAGE 1 OF 1

Boring location: See Site Plan, Figure 2

Logged by: G. Johnson
Drilled By: Gregg

Date started: 4/26/04

Date finished: 4/28/04

Drilling method: 11-inch Hollow-stem auger

Hammer weight/drop: ---

Hammer type: ---

Sampler: split spoon

DEPTH (feet)	SAMPLES				OVM (ppm)	LITHOLOGY	MATERIAL DESCRIPTION	WELL COMPLETION INFORMATION	
	Sample Number	Sample	Blow Count	Recovery (feet)					
1						SAND (SP) brown, dry, rounded, poorly graded, no odor	<p>Flush mounted completion</p> <p>Sch 40 4" PVC, blank from 0 to 8 feet</p> <p>Grout From 3 To 5 Feet</p> <p>Bentonite From 5 To 7 Feet</p> <p>Sch 40 4" PVC 0.050" Vee wire screened casing from 8 to 18 feet</p> <p>Pea gravel from 7 to 21 feet</p> <p>Sch 40 4" PVC, blank from 18 to 21 feet</p>		
2									
3									
4									
5						SP			
6									
7									
8									
9									
10						SM			
11						SAND (SM) blue-gray, moist, rounded, moderately graded, moderate odor			
12									
13									
14	RW-4-13.5					GM			
15						SILTY SAND with GRAVEL (GM) wet, well graded, strong odor increase, material is oily, gravel is at 13.5 feet			
16									
17									
18									
19	RW-4-18.5					SP			
20						SAND (SP) gray, moist, rounded, poorly graded, moderate odor			
21									
22									
23									
24									
25									
26									
27									
28									
29									
30									

Boring terminated at 22 feet.

Treadwell & Rollo

Project No.: 4000.01

Figure:

A-4

TEST ENVIRONMENTAL WELL REV1 400001.GPJ T&R.GDT 7/13/05

Boring location: See Site Plan, Figure 2	Logged by: G. Johnson
Date started: 4/27/04	Date finished: 4/27/04
Drilling method: 11-inch Hollow-stem auger	
Hammer weight/drop: —	Hammer type: —
Sampler: split spoon	

DEPTH (feet)	SAMPLES				OVM (ppm)	LITHOLOGY	MATERIAL DESCRIPTION	WELL COMPLETION INFORMATION
	Sample Number	Sample	Blow Count	Recovery (feet)				
1						SILTY SAND with GRAVEL (SM) dark brown, moist, subrounded, moderately graded, weak odor, 5 percent gravel	Flush mounted completion Sch 40 4" PVC, blank from 0 to 8 feet	
2					SM			
3								
4								
5								
6	RW-5-5.0					weak odor at 5 feet	SAND (SP) light brown, moist, subrounded, poorly graded, weak odor	Grout From 3 To 5 Feet Bentonite From 5 To 7 Feet
7								
8					SP	SILT (ML) dark brown, wet, weak odor, sand is black, but no odor at 11.5 feet	Sch 40 4" PVC 0.050" Vee wire screened casing from 8 to 18 feet Pea gravel from 7 to 21 feet	
9								
10								
11	RW-5-10.0					CLAY (CL) black, soft, moist, slightly plastic, weak odor	Sch 40 4" PVC, blank from 18 to 21 feet	
12					ML			
13								
14								
15								
16	RW-5-16.0					CL		
17					SAND/SILT (SP) moist, subrounded, poorly graded, no odor			
18								
19								
20	RW-5-20.0							
21								
22								
23								
24								
25								
26								
27								
28								
29								
30								

TEST ENVIRONMENTAL WELL REV1 400001.GPJ T&R.GDT 7/13/05

Boring terminated at 22 feet.

PROJECT:

HARBOR FACILITY CENTER
PORT OF OAKLAND
Oakland, California

Log of Recovery Well RW-6

PAGE 1 OF 1

Boring location: See Site Plan, Figure 2

Logged by: G. Johnson
Drilled By: Gregg

Date started: 4/27/04

Date finished: 4/27/04

Drilling method: 11-inch Hollow-stem auger

Hammer weight/drop: --

Hammer type: --

Sampler: split spoon

DEPTH (feet)	SAMPLES				OVM (ppm)	LITHOLOGY	MATERIAL DESCRIPTION	WELL COMPLETION INFORMATION	
	Sample Number	Sample	Blow Count	Recovery (feet)					
1						ML	SANDY SILT with GRAVEL (ML) dark brown, dry, subrounded, moderately graded, 5 percent gravel, 15 percent sand, and 70 percent fines	Flush mounted completion	Sch 40 4" PVC, blank from 0 to 8 feet
2									
3									
4									
5									
6	RW-6-5.0					SP	SAND (SP) light brown, moist, subrounded, very strong odor	Grout From 3 To 5 Feet	Bentonite From 5 To 7 Feet
7									
8									
9						SP	SAND (SP) blue-green, moist, subrounded, poorly graded, moderate odor	Sch 40 4" PVC 0.050" Vee wire screened casing from 8 to 18 feet	Pea gravel from 7 to 21 feet
10									
11	RW-6-10.0								
12									
13									
14						CL	CLAY (CL) dark gray, soft, moist, moderate odor	Sch 40 4" PVC, blank from 18 to 21 feet	
15									
16	RW-6-15.0								
17						SP	SAND (SP) blue-green, moist, subrounded, poorly graded, no odor black at 21 feet		
18									
19									
20									
21	RW-6-20.0								
22									
23									
24									
25									
26									
27									
28									
29									
30									

Boring terminated at 22 feet.

Treadwell & Rollo

Project No.: 4000.01

Figure:

A-6

TEST ENVIRONMENTAL WELL REV1_400001.GPJ T&R.GDT 7/13/05

PROJECT:

HARBOR FACILITY CENTER
PORT OF OAKLAND
Oakland, California

Log of Recovery Well RW-7

PAGE 1 OF 1

Boring location: See Site Plan, Figure 2

Logged by: J. Ludlow
Drilled By: Gregg

Date started: 4/26/04

Date finished: 4/26/04

Drilling method: 11-inch Hollow-stem auger

Hammer weight/drop: —

Hammer type: —

Sampler: split spoon

DEPTH (feet)	SAMPLES				OVM (ppm)	LITHOLOGY	MATERIAL DESCRIPTION	WELL COMPLETION INFORMATION	
	Sample Number	Sample	Blow Count	Recovery (feet)					
1						SM	SILTY SAND with GRAVEL (SM) dark brown, moist, subrounded, moderately graded, no odor, 5 percent gravel, 65 percent sand, 30 percent fines	Flush mounted completion	Sch 40 4" PVC, blank from 0 to 8 feet
2						SM			
3						SM			
4						SM			
5						SM			
6	RW-7-5.0					SP	SAND (SP) light brown, moist, subrounded, poorly graded, no odor	FILL	Grout From 3 To 5 Feet
7						SP			Bentonite From 5 To 7 Feet
8						SP			
9						SP			
10						SP	black oil staining in sample		Sch 40 4" PVC 0.050" Vee wire screened casing from 8 to 18 feet
11	RW-7-10.0					SP	SAND (SP) blue-green, wet, subrounded, poorly graded, weak odor		
12						ML	SILT with SAND (ML) blue-green, wet, moderately graded, moderate odor, 15 percent sand, 85 percent fines		
13						ML			Pea gravel from 7 to 21 feet
14						ML			
15						ML			
16	RW-7-15.0					ML			
17						CL	CLAY (CL) black, soft, moist, weak odor, 100 percent fines		
18						CL			
19						CL			Sch 40 4" PVC, blank from 18 to 21 feet
20						CL			
21	RW-7-20.0					SM	SAND with SILT (SM) green-black, moist to wet, subrounded, moderate odor, 15 percent sand, 85 percent fines.		
22						SM			
23									
24									
25									
26									
27									
28									
29									
30									

Boring terminated at 22 feet.

TEST ENVIRONMENTAL WELL REV1 400001.GPJ T&R.GDT 7/13/05

Treadwell & Rollo

Project No.: 4000.01

Figure:

A-7

PROJECT: HARBOR FACILITY CENTER
PORT OF OAKLAND
Oakland, California

Log of Recovery Well RW-8
PAGE 1 OF 1

Boring location: See Site Plan, Figure 2

Logged by: G. Johnson/J. Ludlow
Drilled By: —

Date started: _____ Date finished: _____

Drilling method: _____

Hammer weight/drop: _____ Hammer type: _____

Sampler: _____

DEPTH (feet)	SAMPLES				OVM (ppm)	LITHOLOGY	MATERIAL DESCRIPTION	WELL COMPLETION INFORMATION
	Sample Number	Sample	Blow Count	Recovery (feet)				
1						GRAVELLY SAND (SW) brown, dry, no odor, 25 percent gravel, 65 percent sand, 10 percent fines	Flush mounted completion Sch 40 4" PVC, blank from 0 to 9 feet	
2					SW			
3								
4								
5								
6								
7						SAND (SP) dry, rounded, poorly graded, no odor	Bentonite From 6 To 8 Feet	
8					SP			
9						SAND (SP) gray, moist, moderate odor start of gravel at 11.5 feet	Sch 40 4" PVC 0.050" Vee wire screened casing from 9 to 19 feet	
10					SP			
11	RW-8-10.0	•						
12								
13					SILTY SAND (SM) wet, moderately graded, moderate odor	Pea gravel from 8 to 22 feet		
14							SM	
15								
16	RW-8-15.0	•						
17					CLAY (CL) black to dark gray, plastic, weak odor	Sch 40 4" PVC, blank from 19 to 22 feet		
18							ML SANDY SILT with SHELLS (ML) black to dark gray, moist, 75 percent sand, 20 percent fines	
19								SP SAND with SILT (SP) blue-green, moist, rounded, poorly graded, no odor, 80 percent sand, 20 percent fines, 5 percent shells
20								
21	RW-8-20.0	•						
22								
23								
24								
25								
26								
27								
28								
29								
30								

Boring terminated at 22 feet.



Project No.: 4000.01 Figure: A-8

TEST ENVIRONMENTAL WELL REV1 400001.GPJ T&R.GDT 7/13/05

PROJECT:

HARBOR FACILITY CENTER
PORT OF OAKLAND
Oakland, California

Log of Recovery Well RW-9

PAGE 1 OF 1

Boring location: See Site Plan, Figure 2

Logged by: G. Johnson
Drilled By: Gregg

Date started: 4/27/04

Date finished: 4/27/04

Drilling method: 11-inch Hollow-stem auger

Hammer weight/drop: —

Hammer type: —

Sampler: split spoon

DEPTH (feet)	SAMPLES				OVM (ppm)	LITHOLOGY	MATERIAL DESCRIPTION	WELL COMPLETION INFORMATION	
	Sample Number	Sample	Blow Count	Recovery (feet)					
1						SM	SILTY SAND with GRAVEL (SM) dark brown, moist, subrounded, moderately graded, no odor, 5 percent gravel, 65 percent sand, 30 percent fines		Flush mounted completion
2						SM			Sch 40 4" PVC, blank from 0 to 9 feet
3						SM			
4						SM			
5						SM			
6	RW-9-5.0					SM	SILTY SAND with GRAVEL (SM) dark brown and black, most, subrounded, moderately graded, weak odor	FILL	Grout From 3 To 6 Feet
7						SP	SAND (SP) light brown, moist, subrounded, poorly graded, no odor, greater than 95 percent sand		Bentonite From 6 To 8 Feet
8						SP			
9						SP			
10						ML	SANDY SILT (ML) blue-green, wet, moderately graded, moderate odor, 15 percent sand, 85 percent fines		Sch 40 4" PVC 0.050" Vee wire screened casing from 9 to 19 feet
11	RW-9-10.0					ML			
12						ML			
13						ML			
14						ML			
15						ML			Pea gravel from 8 to 22 feet
16	RW-9-15.0					ML			
17						CL	CLAY (CL) dark gray, soft, moist, moderate odor		
18						CL			
19						CL			Sch 40 4" PVC, blank from 19 to 22 feet
20						CL			
21	RW-9-21.0					CL	some shell at 21.0 feet		
22									
23									
24									
25									
26									
27									
28									
29									
30									

Boring terminated at 22 feet.

Treadwell & Rollo

Project No.: 4000.01

Figure:

A-9

TEST ENVIRONMENTAL WELL REV1 400001.GPJ T&R.GDT 7/13/05



Attachment 6

Free product thickness and screen submergence data

**TABLE 1. Historical Groundwater Elevation and Free Product Data
Port of Oakland's Harbor Facilities Complex Site
555 - 651 Maritime Street, Oakland, California**

Monitoring Well	Date Measured	Top of Casing (ft amsl)	Depth to Product (ft bTOC)	Depth to Water (ft bTOC)	Product Thickness (ft)	Groundwater Elevation (ft amsl)	Top of Screen (ft bgs)	Top of Screen** (ft amsl)	Submerged (1=Y/0=N)	Historically Submerged (%)
MW-1										
	04/18/00	13.65	NM	8.21	0.0	5.44	5.5	8.15	0	5%
	05/22/00	13.65	NM	8.51	0.0	5.14	5.5	8.15	0	
	07/10/01	13.65	8.8	10.00	1.20	3.65	5.5	8.15	0	
	12/12/01	13.65	NM	NA	NA	NA	5.5	8.15	1	
	03/08/02	13.65	NM	NA	NA	NA	5.5	8.15	1	
	06/13/02	13.65	8.70	10.00	1.30	3.65	5.5	8.15	0	
	09/26/02	13.65	8.60	9.50	0.90	4.15	5.5	8.15	0	
	03/17/03	13.65	7.61	8.88	1.27	4.77	5.5	8.15	0	
	06/18/03	13.65	8.20	9.44	1.24	4.21	5.5	8.15	0	
	09/03/03	13.65	8.50	9.40	0.90	4.25	5.5	8.15	0	
	11/26/03	13.65	8.85	9.25	0.40	4.40	5.5	8.15	0	
	03/05/04	13.65	6.76	7.07	0.31	6.58	5.5	8.15	0	
	06/02/04	13.65	8.26	8.71	0.45	4.94	5.5	8.15	0	
	09/03/04	13.65	8.70	9.11	0.41	4.54	5.5	8.15	0	
	12/16/04	13.65	7.75	7.92	0.17	5.73	5.5	8.15	0	
	03/29/05	13.65	6.21	6.38	0.17	7.27	5.5	8.15	0	
	06/14/05	13.65	7.41	7.61	0.20	6.04	5.5	8.15	0	
	08/10/05	13.65	8.05	8.55	0.50	5.10	5.5	8.15	0	
	09/29/05	13.65	8.28	8.95	0.67	4.70	5.5	8.15	0	
	12/21/05	13.65	5.70	5.90	0.20	7.75	5.5	8.15	0	
	03/24/06	13.65	5.98	6.27	0.29	7.38	5.5	8.15	0	
	07/28/06	13.65	7.88	8.35	0.47	5.30	5.5	8.15	0	
	11/29/06	15.80	10.58	10.81	0.23	4.99	7.65	8.15	0	
	06/01/07	15.80	11.11	11.45	0.34	4.35	7.65	8.15	0	
	11/14/07	15.80	10.87	10.93	0.06	4.87	7.65	8.15	0	
	06/05/08	15.80	11.36	11.46	0.10	4.34	7.65	8.15	0	
	12/18/08	15.80	10.82	10.89	0.07	4.91	7.65	8.15	0	
	03/04/09	15.80	9.38	9.52	0.14	6.28	7.65	8.15	0	
	04/01/09	15.80	10.65	10.67	0.02	5.13	7.65	8.15	0	
	06/17/09	15.80	11.21	11.28	0.07	4.52	7.65	8.15	0	
	12/08/09	15.80	NP	10.79	0.00	5.01	7.65	8.15	0	
	06/17/10	15.80	10.79 ⁴	10.79	0.00	5.01	7.65	8.15	0	
	12/14/10	15.80	9.42 ⁴	9.42	0.00	6.38	7.65	8.15	0	
	06/07/11	15.80	NP	10.77	0.00	5.03	7.65	8.15	0	
	06/21/11	15.80	NP	10.37	0.00	5.43	7.65	8.15	0	
	09/26/11	15.80	11.23 ⁴	11.23	0.00	4.57	7.65	8.15	0	
	12/05/11	15.80	11.15 ⁴	11.15	0.00	4.65	7.65	8.15	0	
	02/06/12	15.80	10.89 ⁴	10.89	0.00	4.91	7.65	8.15	0	
	06/19/12	15.80	11.01 ⁴	11.01	0.00	4.79	7.65	8.15	0	
	09/19/12	15.80	11.40	11.41	0.01	4.39	7.65	8.15	0	
	12/04/12	15.80	NP	9.05	0.00	6.75	7.65	8.15	0	
	06/19/13	15.80	NP	11.34	0.00	4.46	7.65	8.15	0	
MW-2										
	12/31/97	13.87	NP	8.73	0.0	5.14	5.5	8.37	0	0%
	04/13/98	13.87	NP	7.72	0.0	6.15	5.5	8.37	0	
	11/06/98	13.87	NP	9.43	0.0	4.44	5.5	8.37	0	
	03/19/99	13.87	NP	8.21	0.0	5.66	5.5	8.37	0	
	06/24/99	13.87	NP	8.91	0.0	4.96	5.5	8.37	0	
	09/28/99	13.87	NP	9.42	0.0	4.45	5.5	8.37	0	
	11/12/99	13.87	NP	9.63	0.0	4.24	5.5	8.37	0	
	02/11/00	13.87	NP	8.54	0.0	5.33	5.5	8.37	0	
	05/22/00	13.87	NP	8.10	0.0	5.77	5.5	8.37	0	
	09/06/00	13.87	NP	8.79	0.0	5.08	5.5	8.37	0	
	12/19/00	13.87	NP	9.19	0.0	4.68	5.5	8.37	0	
	02/21/01	13.87	NP	7.99	0.0	5.88	5.5	8.37	0	
	04/03/01	13.87	NP	8.23	0.0	5.64	5.5	8.37	0	
	07/10/01	13.87	NP	8.70	0.0	5.17	5.5	8.37	0	
	12/12/01	13.87	NP	8.16	0.0	5.71	5.5	8.37	0	
	01/22/02	13.87	NP	7.64	0.0	6.23	5.5	8.37	0	
	03/08/02	13.87	NP	8.31	0.0	5.56	5.5	8.37	0	
	06/13/02	13.87	NP	8.64	0.0	5.23	5.5	8.37	0	
MW-2 (cont)	09/26/02	13.87	NP	8.95	0.0	4.92	5.5	8.37	0	

**TABLE 1. Historical Groundwater Elevation and Free Product Data
Port of Oakland's Harbor Facilities Complex Site
555 - 651 Maritime Street, Oakland, California**

Monitoring Well	Date Measured	Top of Casing (ft amsl)	Depth to Product (ft bTOC)	Depth to Water (ft bTOC)	Product Thickness (ft)	Groundwater Elevation (ft amsl)	Top of Screen (ft bgs)	Top of Screen** (ft amsl)	Submerged (1=Y/0=N)	Historically Submerged (%)
	12/12/02	13.87	NP	9.17	0.0	4.70	5.5	8.37	0	
	03/17/03	13.87	NP	7.77	0.0	6.10	5.5	8.37	0	
	06/18/03	13.87	NP	8.44	0.0	5.43	5.5	8.37	0	
	09/03/03	13.87	NP	8.98	0.0	4.89	5.5	8.37	0	
	11/26/03	13.87	NP	12.01	0.0	1.86	5.5	8.37	0	
	03/05/04	13.87	NP	9.75	0.0	4.12	5.5	8.37	0	
	06/02/04	13.87	NP	11.22	0.0	2.65	5.5	8.37	0	
	09/03/04	13.87	NP	11.62	0.0	2.25	5.5	8.37	0	
	12/16/04	13.87	NP	10.80	0.0	3.07	5.5	8.37	0	
	03/29/05	13.87	NP	9.67	0.0	4.20	5.5	8.37	0	
	06/14/05	13.87	NP	10.68	0.0	3.19	5.5	8.37	0	
	08/10/05	13.87	NP	11.05	0.0	2.82	5.5	8.37	0	
	09/29/05	13.87	NP	11.32	0.0	2.55	5.5	8.37	0	
	12/21/05	13.87	NP	9.57	0.0	4.30	5.5	8.37	0	
	03/24/06	13.87	NP	9.55	0.0	4.32	5.5	8.37	0	
	07/28/06	13.87	NP	10.85	0.0	3.02	5.5	8.37	0	
	11/29/06	16.43	NP	11.69	0.0	4.74	8.06	8.37	0	
	06/01/07	16.43	NP	11.72	0.0	4.71	8.06	8.37	0	
	11/14/07	16.43	NP	12.28	0.0	4.15	8.06	8.37	0	
	06/05/08	16.43	NP	12.01	0.0	4.42	8.06	8.37	0	
	12/18/08	16.43	NP	12.20	0.0	4.23	8.06	8.37	0	
	03/04/09	16.43	NP	10.19	0.0	6.24	8.06	8.37	0	
	04/01/09	16.43	NP	11.34	0.0	5.09	8.06	8.37	0	
	06/17/09	16.43	NP	11.90	0.0	4.53	8.06	8.37	0	
	12/09/09	16.43	NP	12.13	0.0	4.30	8.06	8.37	0	
	06/16/10	16.43	NP	11.57	0.0	4.86	8.06	8.37	0	
	12/14/10	16.43	NP	11.04	0.0	5.39	8.06	8.37	0	
	06/07/11	16.43	NP	10.70	0.0	5.73	8.06	8.37	0	
	06/21/11	16.43	NP	11.18	0.0	5.25	8.06	8.37	0	
	09/26/11	16.43	NP	11.87	0.0	4.56	8.06	8.37	0	
	12/05/11	16.43	NP	11.95	0.0	4.48	8.06	8.37	0	
	02/06/12	16.43	NP	11.50	0.0	4.93	8.06	8.37	0	
	06/19/12	16.43	NP	11.65	0.0	4.78	8.06	8.37	0	
	09/19/12	16.43	NP	12.03	0.0	4.40	8.06	8.37	0	
	12/04/12	16.43	NP	9.82	0.0	6.61	8.06	8.37	0	
	06/19/13	16.43	NP	12.03	0.0	4.40	8.06	8.37	0	
MW-3										0%
	11/06/98	13.73	8.84	9.94	1.10	3.79	5.5	8.23	0	
	03/19/99	13.73	7.52	8.05	0.53	5.68	5.5	8.23	0	
	06/24/99	13.73	8.38	8.56	0.18	5.17	5.5	8.23	0	
	11/12/99	13.73	9.14	9.23	0.09	4.50	5.5	8.23	0	
	02/11/00	13.73	7.97	8.37	0.40	5.36	5.5	8.23	0	
	03/01/00	13.73	6.59	7.24	0.65	6.49	5.5	8.23	0	
	03/21/00	13.73	6.50	6.56	0.06	7.17	5.5	8.23	0	
	05/22/00	13.73	7.51	8.05	0.54	5.68	5.5	8.23	0	
	06/26/00	13.73	7.82	8.20	0.38	5.53	5.5	8.23	0	
	07/25/00	13.73	7.90	8.92	1.02	4.81	5.5	8.23	0	
	08/31/00	13.73	8.15	9.50	1.35	4.23	5.5	8.23	0	
	09/06/00	13.73	8.21	9.42	1.21	4.31	5.5	8.23	0	
	09/21/00	13.73	8.30	8.88	0.58	4.85	5.5	8.23	0	
	12/19/00	13.73	8.60	9.65	1.05	4.08	5.5	8.23	0	
	02/22/01	13.73	6.36	8.15	1.79	5.58	5.5	8.23	0	
	04/03/01	13.73	7.48	8.88	1.40	4.85	5.5	8.23	0	
	04/23/01	13.73	7.85	9.10	1.25	4.63	5.5	8.23	0	
	05/30/01	13.73	7.75	9.10	1.35	4.63	5.5	8.23	0	
	07/10/01	13.73	8.10	9.60	1.50	4.13	5.5	8.23	0	
	03/08/02	13.73	7.80	8.00	0.20	5.73	5.5	8.23	0	
	04/03/02	13.73	7.60	7.70	0.10	6.03	5.5	8.23	0	
	04/23/02	13.73	7.90	8.40	0.50	5.33	5.5	8.23	0	
	04/25/02	13.73	7.90	8.80	0.90	4.93	5.5	8.23	0	
	05/10/02	13.73	8.10	8.20	0.10	5.53	5.5	8.23	0	
MW-3 (cont)	05/24/02	13.73	8.05	8.10	0.05	5.63	5.5	8.23	0	

**TABLE 1. Historical Groundwater Elevation and Free Product Data
Port of Oakland's Harbor Facilities Complex Site
555 - 651 Maritime Street, Oakland, California**

Monitoring Well	Date Measured	Top of Casing (ft amsl)	Depth to Product (ft bTOC)	Depth to Water (ft bTOC)	Product Thickness (ft)	Groundwater Elevation (ft amsl)	Top of Screen (ft bgs)	Top of Screen** (ft amsl)	Submerged (1=Y/0=N)	Historically Submerged (%)
	06/13/02	13.73	8.10	8.70	0.60	5.03	5.5	8.23	0	
	07/05/02	13.73	8.10	8.95	0.85	4.78	5.5	8.23	0	
	07/19/02	13.73	8.10	8.90	0.80	4.83	5.5	8.23	0	
	07/30/02	13.73	8.10	8.90	0.80	4.83	5.5	8.23	0	
	08/14/02	13.73	8.10	8.90	0.80	4.83	5.5	8.23	0	
	09/13/02	13.73	8.30	9.30	1.00	4.43	5.5	8.23	0	
	09/26/02	13.73	8.30	9.00	0.70	4.73	5.5	8.23	0	
	10/14/02	13.73	8.60	9.50	0.90	4.23	5.5	8.23	0	
	11/04/02	13.73	8.75	9.99	1.24	3.74	5.5	8.23	0	
	11/21/02	13.73	8.59	11.29	2.70	2.44	5.5	8.23	0	
	12/06/02	13.73	8.56	9.30	0.74	4.43	5.5	8.23	0	
	12/18/02	13.73	7.35	8.43	1.08	5.30	5.5	8.23	0	
	12/30/02	13.73	6.50	7.15	0.65	6.58	5.5	8.23	0	
	01/02/03	13.73	6.20	6.20	0.00	7.53	5.5	8.23	0	
	01/03/03	13.73	6.21	6.21	0.00	7.52	5.5	8.23	0	
	01/14/03	13.73	6.20	6.21	0.01	7.52	5.5	8.23	0	
	01/30/03	13.73	6.81	6.85	0.04	6.88	5.5	8.23	0	
	02/18/02	13.73	7.09	7.15	0.06	6.58	5.5	8.23	0	
	02/26/03	13.73	7.04	7.11	0.07	6.62	5.5	8.23	0	
	03/13/03	13.73	7.22	8.11	0.89	5.62	5.5	8.23	0	
	03/17/03	13.73	7.15	7.50	0.35	6.23	5.5	8.23	0	
	04/16/03	13.73	7.27	8.25	0.98	5.48	5.5	8.23	0	
	06/18/03	13.73	7.78	9.00	1.22	4.73	5.5	8.23	0	
	09/03/03	13.73	8.31	9.96	1.65	3.77	5.5	8.23	0	
	11/26/03	13.73	10.79	12.85	2.06	0.88	5.5	8.23	0	
	03/05/04	13.73	8.39	9.85	1.46	3.88	5.5	8.23	0	
	06/02/04	13.73	10.03	11.35	1.32	2.38	5.5	8.23	0	
	09/03/04	13.73	10.46	12.06	1.60	1.67	5.5	8.23	0	
	12/16/04	13.73	9.41	10.38	0.97	3.35	5.5	8.23	0	
	03/29/05	13.73	8.17	9.01	0.84	4.72	5.5	8.23	0	
	06/14/05	13.73	9.59	10.55	0.96	3.18	5.5	8.23	0	
	08/10/05	13.73	9.91	11.15	1.24	2.58	5.5	8.23	0	
	09/29/05	13.73	10.21	11.61	1.40	2.12	5.5	8.23	0	
	12/21/05	13.73	8.21	8.28	0.07	5.45	5.5	8.23	0	
	03/24/06	13.73	8.20	8.82	0.62	4.91	5.5	8.23	0	
	07/28/06	13.73	9.81	9.83	0.02	3.90	5.5	8.23	0	
	11/29/06	15.66	10.72	11.70	0.98	3.96	7.43	8.23	0	
	06/01/07	15.66	10.77	11.46	0.69	4.20	7.43	8.23	0	
	11/14/07	15.66	10.98	12.19	1.21	3.47	7.43	8.23	0	
	06/05/08	15.66	10.51	11.96	1.45	3.70	7.43	8.23	0	
	12/18/08	15.66	10.78	12.00	1.22	4.51	7.43	8.23	0	
	03/04/09	15.66	9.31	9.93	0.62	6.16	7.43	8.23	0	
	04/01/09	15.66	10.38	11.10	0.72	5.06	7.43	8.23	0	
	06/17/09	15.66	10.79	12.30	1.51	4.42	7.43	8.23	0	
	12/08/09	15.66	11.05	12.81	1.76	4.08	7.43	8.23	0	
	06/17/10	15.66	10.39	12.29	1.90	4.70	7.43	8.23	0	
	12/15/10	15.66	10.13	10.74	0.61	5.35	7.43	8.23	0	
	06/07/11	15.66	9.91	10.95	1.04	5.44	7.43	8.23	0	
	06/21/11	15.66	10.74	11.20	0.46	4.78	7.43	8.23	0	
	09/26/11	15.66	10.71	12.55	1.84	4.40	7.43	8.23	0	
	12/05/11	15.66	10.83	12.20	1.37	4.42	7.43	8.23	0	
	02/06/12	15.66	10.60	11.42	0.82	4.81	7.43	8.23	0	
	06/19/12	15.66	10.52	12.04	1.52	4.68	7.43	8.23	0	
	09/19/12	15.66	10.90	13.01	2.11	4.13	7.43	8.23	0	
	12/04/12	15.66	9.64	10.65	1.01	5.72	7.43	8.23	0	
	06/19/13	15.66	10.92	12.45	1.53	4.28	7.43	8.23	0	
MW-4										38%
	12/31/97	12.66	NP	7.09	0.0	5.57	8	4.66	1	
	04/13/98	12.66	NP	7.71	0.0	4.95	8	4.66	1	
	11/06/98	12.66	NP	8.69	0.0	3.97	8	4.66	0	
	03/19/99	12.66	NP	8.00	0.0	4.66	8	4.66	1	
MW-4 (cont)	06/24/99	12.66	NP	8.45	0.0	4.21	8	4.66	0	

**TABLE 1. Historical Groundwater Elevation and Free Product Data
Port of Oakland's Harbor Facilities Complex Site
555 - 651 Maritime Street, Oakland, California**

Monitoring Well	Date Measured	Top of Casing (ft amsl)	Depth to Product (ft bTOC)	Depth to Water (ft bTOC)	Product Thickness (ft)	Groundwater Elevation (ft amsl)	Top of Screen (ft bgs)	Top of Screen** (ft amsl)	Submerged (1=Y/0=N)	Historically Submerged (%)
	09/28/99	12.66	NP	8.73	0.0	3.93	8	4.66	0	
	11/12/99	12.66	NP	8.83	0.0	3.83	8	4.66	0	
	02/11/00	12.66	NP	7.71	0.0	4.95	8	4.66	1	
	05/22/00	12.66	NP	8.09	0.0	4.57	8	4.66	0	
	09/06/00	12.66	NP	8.32	0.0	4.34	8	4.66	0	
	12/19/00	12.66	NP	8.47	0.0	4.19	8	4.66	0	
	02/21/01	12.66	NP	7.51	0.0	5.15	8	4.66	1	
	04/03/01	12.66	NP	8.13	0.0	4.53	8	4.66	0	
	07/10/01	12.66	NP	8.12	0.0	4.54	8	4.66	0	
	12/12/01	12.66	NP	7.65	0.0	5.01	8	4.66	1	
	01/22/02	12.66	NP	7.60	0.0	5.06	8	4.66	1	
	03/08/02	12.66	NP	7.96	0.0	4.70	8	4.66	1	
	06/13/02	12.66	NP	8.20	0.0	4.46	8	4.66	0	
	09/26/02	12.66	NP	8.21	0.0	4.45	8	4.66	0	
	12/12/02	12.66	NP	8.38	0.0	4.28	8	4.66	0	
	03/17/03	12.66	NP	7.72	0.0	4.94	8	4.66	1	
	06/18/03	12.66	NP	8.02	0.0	4.64	8	4.66	0	
	09/03/03	12.66	NP	8.29	0.0	4.37	8	4.66	0	
	11/26/03	12.66	NP	8.69	0.0	3.97	8	4.66	0	
	03/05/04	12.66	NP	7.45	0.0	5.21	8	4.66	1	
	06/02/04	12.66	NP	8.25	0.0	4.41	8	4.66	0	
	09/03/04	12.66	NP	8.31	0.0	4.35	8	4.66	0	
	12/16/04	12.66	NP	7.96	0.0	4.70	8	4.66	1	
	03/29/05	12.66	NP	7.11	0.0	5.55	8	4.66	1	
	06/14/05	12.66	NP	7.90	0.0	4.76	8	4.66	1	
	08/10/05	12.66	NP	7.86	0.0	4.80	8	4.66	1	
	09/29/05	12.66	NP	8.00	0.0	4.66	8	4.66	1	
	12/21/05	12.66	NP	7.30	0.0	5.36	8	4.66	1	
	03/24/06	12.66	NP	7.05	0.0	5.61	8	4.66	1	
	07/28/06	12.66	NP	7.92	0.0	4.74	8	4.66	1	
	11/29/06	15.91	NP	11.63	0.0	4.28	11.25	4.66	0	
	06/01/07	15.91	NP	11.82	0.0	4.09	11.25	4.66	0	
	11/14/07	15.91	NP	11.88	0.0	4.03	11.25	4.66	0	
	06/05/08	15.91	NP	11.67	0.0	4.24	11.25	4.66	0	
	12/18/08	15.91	NP	11.20	0.0	4.71	11.25	4.66	1	
	03/04/09	15.91	NP	10.93	0.0	4.98	11.25	4.66	1	
	04/01/09	15.91	NP	11.63	0.0	4.28	11.25	4.66	0	
	06/17/09	15.91	NP	11.88	0.0	4.03	11.25	4.66	0	
	12/08/09	15.91	NP	12.03	0.0	3.88	11.25	4.66	0	
	06/16/10	15.91	NP	11.75	0.0	4.16	11.25	4.66	0	
	12/14/10	15.91	NP	11.62	0.0	4.29	11.25	4.66	0	
	06/07/11	15.91	NP	11.80	0.0	4.11	11.25	4.66	0	
	06/21/11	15.91	NP	11.42	0.0	4.49	11.25	4.66	0	
	09/26/11	15.91	NP	11.83	0.0	4.08	11.25	4.66	0	
	12/05/11	15.91	NP	12.03	0.0	3.88	11.25	4.66	0	
	02/06/12	15.91	NP	11.71	0.0	4.20	11.25	4.66	0	
	06/19/12	15.91	NP	11.73	0.0	4.18	11.25	4.66	0	
	09/19/12	15.91	NP	11.90	0.0	4.01	11.25	4.66	0	
	12/04/12	15.91	NP	10.95	0.0	4.96	11.25	4.66	1	
	06/19/13	15.91	NP	12.04	0.0	3.87	11.25	4.66	0	
MW-5										98%
	12/31/97	13.00	NP	6.38	0.0	6.62	8	5	1	
	04/13/98	13.00	NP	5.56	0.0	7.44	8	5	1	
	11/06/98	13.00	NP	6.59	0.0	6.41	8	5	1	
	03/19/99	13.00	NP	6.20	0.0	6.80	8	5	1	
	06/24/99	13.00	NP	6.73	0.0	6.27	8	5	1	
	09/28/99	13.00	NP	6.91	0.0	6.09	8	5	1	
	11/12/99	13.00	NP	7.06	0.0	5.94	8	5	1	
	02/11/00	13.00	NP	7.00	0.0	6.00	8	5	1	
	05/22/00	13.00	NP	6.21	0.0	6.79	8	5	1	
	09/06/00	13.00	NP	6.56	0.0	6.44	8	5	1	
MW-5 (cont)	12/19/00	13.00	NP	6.68	0.0	6.32	8	5	1	

**TABLE 1. Historical Groundwater Elevation and Free Product Data
Port of Oakland's Harbor Facilities Complex Site
555 - 651 Maritime Street, Oakland, California**

Monitoring Well	Date Measured	Top of Casing (ft amsl)	Depth to Product (ft bTOC)	Depth to Water (ft bTOC)	Product Thickness (ft)	Groundwater Elevation (ft amsl)	Top of Screen (ft bgs)	Top of Screen** (ft amsl)	Submerged (1=Y/0=N)	Historically Submerged (%)
	02/21/01	13.00	NP	6.08	0.0	6.92	8	5	1	
	04/03/01	13.00	NP	6.38	0.0	6.62	8	5	1	
	07/10/01	13.00	NP	6.58	0.0	6.42	8	5	1	
	12/12/01	13.00	NP	6.40	0.0	6.60	8	5	1	
	01/22/02	13.00	NP	6.10	0.0	6.90	8	5	1	
	03/08/02	13.00	NP	6.10	0.0	6.90	8	5	1	
	06/13/02	13.00	NP	6.31	0.0	6.69	8	5	1	
	09/26/02	13.00	NP	6.60	0.0	6.40	8	5	1	
	12/12/02	13.00	NP	6.75	0.0	6.25	8	5	1	
	03/17/03	13.00	NP	5.73	0.0	7.27	8	5	1	
	06/18/03	13.00	NP	6.10	0.0	6.90	8	5	1	
	09/03/03	13.00	NP	6.50	0.0	6.50	8	5	1	
	11/26/03	13.00	NP	6.70	0.0	6.30	8	5	1	
	03/05/04	13.00	NP	5.70	0.0	7.30	8	5	1	
	06/02/04	13.00	NP	6.27	0.0	6.73	8	5	1	
	09/03/04	13.00	NP	6.61	0.0	6.39	8	5	1	
	12/16/04	13.00	NP	6.02	0.0	6.98	8	5	1	
	03/29/05	13.00	NP	5.25	0.0	7.75	8	5	1	
	06/14/05	13.00	NP	5.82	0.0	7.18	8	5	1	
	08/10/05	13.00	NP	6.00	0.0	7.00	8	5	1	
	09/29/05	13.00	NP	6.26	0.0	6.74	8	5	1	
	12/21/05	13.00	NP	5.91	0.0	7.09	8	5	1	
	03/24/06	13.00	NP	NA ²	NA ²	NA	8	5	1	
	07/28/06	13.00	NP	6.08	0.0	6.92	8	5	1	
	11/29/06	15.39	NP	9.39	0.0	6.00	10.39	5	1	
	06/01/07	15.39	NP	10.60	0.0	4.79	10.39	5	0	
	11/14/07	15.39	NP	9.77	0.0	5.62	10.39	5	1	
	06/05/08	15.39	NP	9.74	0.0	5.65	10.39	5	1	
	12/18/08	15.39	NP	9.80	0.0	5.59	10.39	5	1	
	03/04/09	15.39	NP	8.78	0.0	6.61	10.39	5	1	
	04/01/09	15.39	NP	9.16	0.0	6.23	10.39	5	1	
	06/17/09	15.39	NP	9.51	0.0	5.88	10.39	5	1	
	12/08/09	15.39	NP	9.52	0.0	5.87	10.39	5	1	
	06/16/10	15.39	NP	9.31	0.0	6.08	10.39	5	1	
	12/14/10	15.39	NP	9.31	0.0	6.08	10.39	5	1	
	06/07/11	15.39	NP	9.06	0.0	6.33	10.39	5	1	
	06/21/11	15.39	NP	9.06	0.0	6.33	10.39	5	1	
	09/26/11	15.39	NP	9.30	0.0	6.09	10.39	5	1	
	12/05/11	15.39	NP	9.31	0.0	6.08	10.39	5	1	
	02/06/12	15.39	NP	9.32	0.0	6.07	10.39	5	1	
	06/19/12	15.39	NP	9.16	0.0	6.23	10.39	5	1	
	09/19/12	15.39	NP	9.39	0.0	6.00	10.39	5	1	
	12/04/12	15.39	NP	9.17	0.0	6.22	10.39	5	1	
	06/19/13	15.39	NP	9.32	0.0	6.07	10.39	5	1	
MW-6										75%
	06/24/99	13.51	NP	8.61	0.0	4.90	8	5.51	0	
	09/28/99	13.51	NP	9.26	0.0	4.25	8	5.51	0	
	11/12/99	13.51	NP	8.01	0.0	5.50	8	5.51	0	
	02/11/00	13.51	NP	7.20	0.0	6.31	8	5.51	1	
	05/22/00	13.51	NP	7.13	0.0	6.38	8	5.51	1	
	09/06/00	13.51	NP	7.12	0.0	6.39	8	5.51	1	
	12/19/00	13.51	NP	7.57	0.0	5.94	8	5.51	1	
	02/21/01	13.51	NP	7.50	0.0	6.01	8	5.51	1	
	04/03/01	13.51	NP	6.88	0.0	6.63	8	5.51	1	
	07/10/01	13.51	NP	7.15	0.0	6.36	8	5.51	1	
	12/12/01	13.51	NP	9.50	0.0	4.01	8	5.51	0	
	01/22/02	13.51	NP	6.69	0.0	6.82	8	5.51	1	
	03/08/02	13.51	NP	6.98	0.0	6.53	8	5.51	1	
	06/13/02	13.51	NP	7.45	0.0	6.06	8	5.51	1	
	09/26/02	13.51	NP	7.95	0.0	5.56	8	5.51	1	
	12/12/02	13.51	NP	7.71	0.0	5.80	8	5.51	1	
	12/18/02					Monitoring well was destroyed				

**TABLE 1. Historical Groundwater Elevation and Free Product Data
Port of Oakland's Harbor Facilities Complex Site
555 - 651 Maritime Street, Oakland, California**

Monitoring Well	Date Measured	Top of Casing (ft amsl)	Depth to Product (ft bTOC)	Depth to Water (ft bTOC)	Product Thickness (ft)	Groundwater Elevation (ft amsl)	Top of Screen (ft bgs)	Top of Screen** (ft amsl)	Submerged (1=Y/0=N)	Historically Submerged (%)
MW-7										
	12/31/97	13.86	NP	8.88	0.0	4.98	8	5.86	0	10%
	04/13/98	13.86	NP	7.86	0.0	6.00	8	5.86	1	
	11/06/98	13.86	NP	9.55	0.0	4.31	8	5.86	0	
	03/19/99	13.86	NP	8.41	0.0	5.45	8	5.86	0	
	06/24/99	13.86	NP	9.08	0.0	4.78	8	5.86	0	
	09/28/99	13.86	NP	9.60	0.0	4.26	8	5.86	0	
	11/12/99	13.86	NP	9.77	0.0	4.09	8	5.86	0	
	02/11/00	13.86	NP	8.67	0.0	5.19	8	5.86	0	
	05/22/00	13.86	NP	8.43	0.0	5.43	8	5.86	0	
	09/06/00	13.86	NP	8.88	0.0	4.98	8	5.86	0	
	12/19/00	13.86	NP	9.21	0.0	4.65	8	5.86	0	
	02/21/01	13.86	NP	8.13	0.0	5.73	8	5.86	0	
	04/03/01	13.86	NP	8.45	0.0	5.41	8	5.86	0	
	07/10/01	13.86	NP	8.87	0.0	4.99	8	5.86	0	
	12/12/01	13.86	NP	8.39	0.0	5.47	8	5.86	0	
	01/22/02	13.86	NP	7.99	0.0	5.87	8	5.86	1	
	03/08/02	13.86	NP	8.51	0.0	5.35	8	5.86	0	
	06/13/02	13.86	NP	8.90	0.0	4.96	8	5.86	0	
	09/26/02	13.86	NP	9.00	0.0	4.86	8	5.86	0	
	12/12/02	13.86	NP	9.28	0.0	4.58	8	5.86	0	
	12/18/02	Monitoring well was destroyed								
MW-8³										
	12/31/97	12.45	8.49	8.82	0.33	3.63	8	4.45	0	0%
	11/06/98	12.45	9.25	10.30	1.05	2.15	8	4.45	0	
	11/21/98	Monitoring well was destroyed and replaced with well MW-8A								
MW-8A										
	12/12/01	12.45	NP	7.20	0.0	5.25	5	7.45	0	0%
	01/22/02	12.45	NP	7.20	0.0	5.25	5	7.45	0	
	03/08/02	12.45	NP	7.70	0.0	4.75	5	7.45	0	
	06/13/02	12.45	NP	7.72	0.0	4.73	5	7.45	0	
	09/26/02	12.45	NP	7.91	0.0	4.54	5	7.45	0	
	12/12/02	12.45	NP	8.15	0.0	4.30	5	7.45	0	
	03/17/03	12.45	NP	7.28	0.0	5.17	5	7.45	0	
	06/18/03	12.45	NP	7.72	0.0	4.73	5	7.45	0	
	09/03/03	12.45	NP	8.18	0.0	4.27	5	7.45	0	
	11/26/03	12.45	NP	8.55	0.0	3.90	5	7.45	0	
	03/05/04	12.45	NP	6.92	0.0	5.53	5	7.45	0	
	06/02/04	12.45	NP	7.92	0.0	4.53	5	7.45	0	
	09/03/04	12.45	NP	8.16	0.0	4.29	5	7.45	0	
	12/16/04	12.45	NP	7.62	0.0	4.83	5	7.45	0	
	03/29/05	12.45	NP	6.63	0.0	5.82	5	7.45	0	
	06/14/05	12.45	NP	7.60	0.0	4.85	5	7.45	0	
	08/10/05	12.45	NP	7.50	0.0	4.95	5	7.45	0	
	09/29/05	12.45	NP	7.76	0.0	4.69	5	7.45	0	
	12/21/05	12.45	NP	6.90	0.0	5.55	5	7.45	0	
	03/24/06	12.45	NP	6.65	0.0	5.80	5	7.45	0	
	07/28/06	12.45	NP	7.34	0.0	5.11	5	7.45	0	
	11/29/06	14.99	NP	11.41	0.0	3.58	7.54	7.45	0	
	06/01/07	14.99	NP	11.26	0.0	3.73	7.54	7.45	0	
	11/14/07	14.99	NP	11.40	0.0	3.59	7.54	7.45	0	
	06/05/08	14.99	NP	11.45	0.0	3.54	7.54	7.45	0	
	12/18/08	14.99	NP	11.30	0.0	3.69	7.54	7.45	0	
	03/04/09	14.99	NP	10.07	0.0	4.92	7.54	7.45	0	
	04/01/09	14.99	NP	10.92	0.0	4.07	7.54	7.45	0	
	06/17/09	14.99	NP	11.40	0.0	3.59	7.54	7.45	0	
	12/08/09	14.99	NP	11.64	0.0	3.35	7.54	7.45	0	
	06/16/10	14.99	NP	11.75	0.0	3.24	7.54	7.45	0	
	12/14/10	14.99	NP	10.75	0.0	4.24	7.54	7.45	0	
	06/07/11	14.99	NP	10.51	0.0	4.48	7.54	7.45	0	
	06/21/11	14.99	NP	10.64	0.0	4.35	7.54	7.45	0	
	09/26/11	14.99	NP	11.21	0.0	3.78	7.54	7.45	0	
	12/05/11	14.99	NP	11.29	0.0	3.70	7.54	7.45	0	
	02/06/12	14.99	NP	10.75	0.0	4.24	7.54	7.45	0	
	06/19/12	14.99	NP	11.04	0.0	3.95	7.54	7.45	0	
	09/19/12	14.99	NP	11.38	0.0	3.61	7.54	7.45	0	
	12/04/12	14.99	NP	9.87	0.0	5.12	7.54	7.45	0	
	06/19/13	14.99	NP	11.44	0.0	3.55	7.54	7.45	0	

**TABLE 1. Historical Groundwater Elevation and Free Product Data
Port of Oakland's Harbor Facilities Complex Site
555 - 651 Maritime Street, Oakland, California**

Monitoring Well	Date Measured	Top of Casing (ft amsl)	Depth to Product (ft bTOC)	Depth to Water (ft bTOC)	Product Thickness (ft)	Groundwater Elevation (ft amsl)	Top of Screen (ft bgs)	Top of Screen** (ft amsl)	Submerged (1=Y/0=N)	Historically Submerged (%)
MW-9										
	12/18/08	16.33	NP	12.88	0.0	3.45	15	1.33	1	100%
	03/04/09	16.33	NP	11.04	0.0	5.29	15	1.33	1	
	04/01/09	16.33	NP	11.51	0.0	4.82	15	1.33	1	
	06/17/09	16.33	NP	11.95	0.0	4.38	15	1.33	1	
	12/08/09	16.33	NP	12.30	0.0	4.03	15	1.33	1	
	06/16/10	16.33	NP	11.75	0.0	4.58	15	1.33	1	
	12/14/10	16.33	NP	11.51	0.0	4.82	15	1.33	1	
	06/07/11	16.33	NP	11.32	0.0	5.01	15	1.33	1	
	06/21/11	16.33	NP	11.37	0.0	4.96	15	1.33	1	
	09/26/11	16.33	NP	11.92	0.0	4.41	15	1.33	1	
	12/05/11	16.33	NP	11.99	0.0	4.34	15	1.33	1	
	02/06/12	16.33	NP	11.70	0.0	4.63	15	1.33	1	
	06/19/12	16.33	NP	11.76	0.0	4.57	15	1.33	1	
	09/19/12	16.33	NP	12.03	0.0	4.30	15	1.33	1	
	12/04/12	16.33	NP	11.15	0.0	5.18	15	1.33	1	
	06/19/13	16.33	NP	12.12	0.0	4.21	15	1.33	1	
MW-10										
	12/18/08	15.65	NP	14.34	0.0	1.31	15	0.65	1	100%
	03/04/09	15.65	NP	9.78	0.0	5.87	15	0.65	1	
	04/01/09	15.65	NP	10.33	0.0	5.32	15	0.65	1	
	06/17/09	15.65	NP	10.79	0.0	4.86	15	0.65	1	
	12/08/09	15.65	NP	10.96	0.0	4.69	15	0.65	1	
	06/16/10	15.65	NP	10.62	0.0	5.03	15	0.65	1	
	12/14/10	15.65	NP	10.31	0.0	5.34	15	0.65	1	
	06/07/11	15.65	NP	10.11	0.0	5.54	15	0.65	1	
	06/21/11	15.65	NP	10.19	0.0	5.46	15	0.65	1	
	09/26/11	15.65	NP	10.79	0.0	4.86	15	0.65	1	
	12/05/11	15.65	NP	10.80	0.0	4.85	15	0.65	1	
	02/06/12	15.65	NP	10.51	0.0	5.14	15	0.65	1	
	06/19/12	15.65	NP	10.61	0.0	5.04	15	0.65	1	
	09/19/12	15.65	NP	10.57	0.0	5.08	15	0.65	1	
	12/04/12	15.65	NP	9.96	0.0	5.69	15	0.65	1	
	06/19/13	15.65	NP	10.90	0.0	4.75	15	0.65	1	
MW-11										
	12/18/08	15.47	NP	13.42	0.0	2.05	15	0.47	1	100%
	03/04/09	15.47	NP	9.57	0.0	5.90	15	0.47	1	
	04/01/09	15.47	NP	9.94	0.0	5.53	15	0.47	1	
	06/17/09	15.47	NP	10.40	0.0	5.07	15	0.47	1	
	12/09/09	15.47	NP	10.68	0.0	4.79	15	0.47	1	
	06/16/10	15.47	NP	10.02	0.0	5.45	15	0.47	1	
	12/01/10	15.47	NP	10.02	0.0	5.45	15	0.47	1	
	06/07/11	15.47	NP	10.00	0.0	5.47	15	0.47	1	
	06/21/11	15.47	NP	9.85	0.0	5.62	15	0.47	1	
	09/26/11	15.47	NP	10.33	0.0	5.14	15	0.47	1	
	12/05/11	15.47	NP	10.59	0.0	4.88	15	0.47	1	
	02/06/12	15.47	NP	10.59	0.0	4.88	15	0.47	1	
	06/19/12	15.47	NP	10.12	0.0	5.35	15	0.47	1	
	09/19/12	15.47	NP	10.54	0.0	4.93	15	0.47	1	
	12/04/12	15.47	NP	9.65	0.0	5.82	15	0.47	1	
	06/19/13	15.47	NP	10.53	0.0	4.94	15	0.47	1	
MW-12										
	12/18/08	16.79	NP	12.75	0.0	4.04	15	1.79	1	100%
	03/04/09	16.79	NP	10.60	0.0	6.19	15	1.79	1	
	04/01/09	16.79	NP	11.23	0.0	5.56	15	1.79	1	
	6/17/2009	16.79	NP	11.83	0.0	4.96	15	1.79	1	
	12/8/2009	16.79	NP	12.13	0.0	4.66	15	1.79	1	
	6/16/2010	16.79	NP	11.31	0.0	5.48	15	1.79	1	
	12/14/2010	16.79	NP	11.15	0.0	5.64	15	1.79	1	
	6/7/2011	16.79	NP	10.81	0.0	5.98	15	1.79	1	
	6/21/2011	16.79	NP	11.01	0.0	5.78	15	1.79	1	
	9/26/2011	16.79	NP	11.77	0.0	5.02	15	1.79	1	
	12/5/2011	16.79	NP	11.89	0.0	4.90	15	1.79	1	
	2/6/2012	16.79	NP	11.60	0.0	5.19	15	1.79	1	
	6/19/2012	16.79	NP	11.49	0.0	5.30	15	1.79	1	
	9/19/2012	16.79	NP	12.04	0.0	4.75	15	1.79	1	
	12/4/2012	16.79	NP	10.74	0.0	6.05	15	1.79	1	
	6/19/2013	16.79	NP	12.01	0.0	4.78	15	1.79	1	

**TABLE 1. Historical Groundwater Elevation and Free Product Data
 Port of Oakland's Harbor Facilities Complex Site
 555 - 651 Maritime Street, Oakland, California**

Monitoring Well	Date Measured	Top of Casing (ft amsl)	Depth to Product (ft bTOC)	Depth to Water (ft bTOC)	Product Thickness (ft)	Groundwater Elevation (ft amsl)	Top of Screen (ft bgs)	Top of Screen** (ft amsl)	Submerged (1=Y/0=N)	Historically Submerged (%)
-----------------	---------------	-------------------------	----------------------------	--------------------------	------------------------	---------------------------------	------------------------	---------------------------	---------------------	----------------------------

Notes:

ft amsl = feet above mean sea level

ft bTOC = feet below top of casing

ft bgs = feet below ground surface

NP = no product detected with the interface probe

** = Ground elevation assumed to be approximately equal to casing elevation at time of install (top of screen elevation does not change when grade elevation changes)

NA = Not Available

**TABLE 2. Free Product Recovery System Groundwater Elevation and Free Product Data
Port of Oakland's Harbor Facilities Complex Site
555 - 651 Maritime Street, Oakland, California**

Recovery Well	Date Measured	Top of Casing (ft amsl)	Depth to Product (ft bTOC)	Depth to Water (ft bTOC)	Product Thickness (ft)	Groundwater Elevation (ft amsl)	Top of Screen (ft bgs)	Top of Screen** (ft amsl)	Submerged (1=Y/0=N)	Historically Submerged (%)
RW-1										
	5/11/2004	NA	NP	6.6	NP	NA	5	NA	NA	NA
	10/5/2004*	NA	NP	8.45	NP	NA	5	NA	NA	NA
	2/10/2005	NA	--	--	--	NA	5	NA	NA	NA
	5/6/2005	NA	--	--	--	NA	5	NA	NA	NA
	9/12/2005*	NA	NP	7.85	NP	NA	5	NA	NA	NA
	11/2/2005	NA	NP	8.12	NP	NA	5	NA	NA	NA
	2/3/2006	NA	--	--	--	NA	5	NA	NA	NA
	4/23/2006*	NA	--	--	--	NA	5	NA	NA	NA
	8/18/2006	NA	--	--	--	NA	5	NA	NA	NA
	11/2/2006	12.95	--	--	--	NA	NA	NA	NA	NA
	2/1/2007	12.95	--	--	--	NA	NA	NA	NA	NA
	5/3/2007	12.95	--	--	--	NA	NA	NA	NA	NA
	8/2/2007	12.95	--	--	--	NA	NA	NA	NA	NA
	11/2/2007	12.95	--	--	--	NA	NA	NA	NA	NA
	2/1/2008	12.95	--	--	--	NA	NA	NA	NA	NA
	5/2/2008	12.95	--	--	--	NA	NA	NA	NA	NA
	8/1/2008	12.95	--	--	--	NA	NA	NA	NA	NA
	11/7/2008	12.95	--	--	--	NA	NA	NA	NA	NA
	2/4/2009	12.95	--	--	--	NA	NA	NA	NA	NA
	5/4/2009	12.95	--	--	--	NA	NA	NA	NA	NA
	8/5/2009	12.95	--	--	--	NA	NA	NA	NA	NA
	11/4/2009	12.95	--	--	--	NA	NA	NA	NA	NA
	2/3/2010	12.95	--	--	--	NA	NA	NA	NA	NA
	5/5/2010	12.95	--	--	--	NA	NA	NA	NA	NA
	8/11/2010	12.95	--	--	--	NA	NA	NA	NA	NA
	11/3/2010	12.95	--	--	--	NA	NA	NA	NA	NA
Well inaccessible; product and water levels not measured.										
RW-2										
	5/11/2004	NA	NP	9.1	NP	--	8	NA	NA	NA
	10/5/2004*	NA	--	--	--	--	8	NA	NA	NA
	2/10/2005	NA	--	--	--	--	8	NA	NA	NA
	5/6/2005	NA	--	--	--	--	8	NA	NA	NA
	9/12/2005*	NA	NP	10.23	NP	--	8	NA	NA	NA
	11/2/2005	NA	NP	10.5	NP	--	8	NA	NA	NA
	2/3/2006	NA	NP	7.66	NP	--	8	NA	NA	NA
	4/23/2006*	NA	--	--	--	--	8	NA	NA	NA
	8/18/2006	NA	--	9.93	--	--	8	NA	NA	NA
	11/2/2006	15.56	--	--	--	--	NA	NA	NA	NA
	2/1/2007	15.56	--	--	--	--	NA	NA	NA	NA
	5/3/2007	15.56	--	--	--	--	NA	NA	NA	NA
	8/2/2007	15.56	--	--	--	--	NA	NA	NA	NA
	11/2/2007	15.56	--	--	--	--	NA	NA	NA	NA
	2/1/2008	15.56	--	--	--	--	NA	NA	NA	NA
	5/2/2008	15.56	--	--	--	--	NA	NA	NA	NA
	8/1/2008	15.56	--	--	--	--	NA	NA	NA	NA
	11/7/2008	15.56	--	--	--	--	NA	NA	NA	NA
	2/4/2009	15.56	--	--	--	--	NA	NA	NA	NA
	5/4/2009	15.56	--	--	--	--	NA	NA	NA	NA
	8/5/2009	15.56	--	--	--	--	NA	NA	NA	NA
	11/4/2009	15.56	--	--	--	--	NA	NA	NA	NA
	2/3/2010	15.56	--	--	--	--	NA	NA	NA	NA
	5/5/2010	15.56	--	--	--	--	NA	NA	NA	NA
	8/11/2010	15.56	--	--	--	--	NA	NA	NA	NA
	11/3/2010	15.56	--	--	--	--	NA	NA	NA	NA
	06/07/11	15.56	NP	7.19	0.00	8.37	NA	NA	NA	NA
	06/21/11	15.56	NP	9.02	0.00	6.54	NA	NA	NA	NA
	12/05/11	15.56	NP	9.44	0.00	6.12	NA	NA	NA	NA
	02/06/12	15.56	NP	9.22	0.00	6.34	NA	NA	NA	NA
	06/20/12	15.56	NP	9.80	0.00	5.76	NA	NA	NA	NA
	09/19/12	15.56	NP	10.35	0.00	5.21	NA	NA	NA	NA
	12/04/12	15.56	NP	6.89	0.00	8.67	NA	NA	NA	NA
	06/19/13	15.56	NP	10.13	0.00	5.43	NA	NA	NA	NA
RW-3										
	5/11/2004	NA	NP	8.9	NP	--	8	NA	NA	NA
	10/5/2004*	NA	10.81	10.84	0.03	--	8	NA	NA	NA
	2/10/2005	NA	9.26	10.66	1.4	--	8	NA	NA	NA

**TABLE 2. Free Product Recovery System Groundwater Elevation and Free Product Data
Port of Oakland's Harbor Facilities Complex Site
555 - 651 Maritime Street, Oakland, California**

Recovery Well	Date Measured	Top of Casing (ft amsl)	Depth to Product (ft bTOC)	Depth to Water (ft bTOC)	Product Thickness (ft)	Groundwater Elevation (ft amsl)	Top of Screen (ft bgs)	Top of Screen** (ft amsl)	Submerged (1=Y/0=N)	Historically Submerged (%)
RW-3 (cont.)	5/6/2005	NA	8.99	9.88	0.89	--	8	NA	NA	
	9/12/2005*	NA	10.11	11.11	1	--	8	NA	NA	
	11/2/2005	NA	10.57	10.82	0.25	--	8	NA	NA	
	2/3/2006	NA	8.35	8.7	0.35	--	8	NA	NA	
	4/23/2006*	NA	8.85	8.97	0.12	--	8	NA	NA	
	8/18/2006	NA	--	9.89	--	--	8	NA	NA	
	11/2/2006	15.56	10.65	10.67	0.02	4.89	NA	NA	NA	
	2/1/2007	15.56	10.65	10.66	0.01	4.9	NA	NA	NA	
	5/3/2007	15.56	10.71	10.81	0.1	4.75	NA	NA	NA	
	8/2/2007	15.56	11	11.05	0.05	4.51	NA	NA	NA	
	11/2/2007	15.56	--	--	--	--	NA	NA	NA	
	2/1/2008	15.56	10.77	11.91	1.14	3.65	NA	NA	NA	
	5/2/2008	15.56	10.64	11.66	1.02	3.9	NA	NA	NA	
	8/1/2008	15.56	10.75	11.05	0.3	4.51	NA	NA	NA	
	11/7/2008	15.56	10.22	10.9	0.68	4.66	NA	NA	NA	
	2/4/2009	15.56	11.2	11.32	0.12	4.24	NA	NA	NA	
	5/4/2009	15.56	10.82	11.41	0.59	4.15	NA	NA	NA	
	8/5/2009	15.56	11.1	11.14	0.04	4.42	NA	NA	NA	
	11/4/2009	15.56	10.83	11.24	0.41	4.32	NA	NA	NA	
	2/3/2010	15.56	9.51	12.2	2.69	3.36	NA	NA	NA	
	5/5/2010	15.56	10.07	10.9	0.83	4.66	NA	NA	NA	
	8/11/2010	15.56	10.81	11.19	0.38	4.37	NA	NA	NA	
	11/3/2010	15.56	10.99	11.72	0.73	3.84	NA	NA	NA	
	01/12/11	15.56	9.87	11.04	1.17	5.34	NA	NA	NA	
	01/26/11	15.56	10.28	10.43	0.15	5.24	NA	NA	NA	
	02/10/11	15.56	10.45	10.90	0.45	4.98	NA	NA	NA	
	02/24/11	15.56	9.42	12.13	2.71	5.33	NA	NA	NA	
	03/09/11	15.56	9.45	13.04	3.60	5.04	NA	NA	NA	
	03/23/11	15.56	8.63	12.18	3.55	5.87	NA	NA	NA	
	04/06/11	15.56	9.10	11.49	2.39	5.74	NA	NA	NA	
04/20/11	15.56	9.70	10.88	1.18	5.51	NA	NA	NA		
05/04/11	15.56	10.05	10.47	0.42	5.38	NA	NA	NA		
05/18/11	15.56	9.95	10.17	0.22	5.54	NA	NA	NA		
06/07/11	15.56	9.73	13.52	3.79	4.69	NA	NA	NA		
06/21/11	15.56	10.10	11.20	1.10	5.13	NA	NA	NA		
09/26/11	15.56	10.63	12.66	2.03	4.32	NA	NA	NA		
10/05/11	15.56	10.48	10.98	0.50	4.93	NA	NA	NA		
10/19/11	15.56	10.64	11.91	1.27	4.54	NA	NA	NA		
12/05/11	15.56	10.75	12.67	1.92	4.23	NA	NA	NA		
02/06/12	15.56	10.32	12.54	2.22	4.57	NA	NA	NA		
06/20/12	15.56	10.38	12.56	2.18	4.53	NA	NA	NA		
09/19/12	15.56	10.87	13.07	2.20	4.03	NA	NA	NA		
12/04/12	15.56	9.35	13.54	4.19	4.95	NA	NA	NA		
06/19/13	15.56	10.75	13.62	2.87	3.95	NA	NA	NA		
RW-4										NA
	5/11/2004	NA	7.7	7.75	0.05	--	8	NA	NA	
	10/5/2004*	NA	10.06	10.11	0.05	--	8	NA	NA	
	2/10/2005	NA	8.3	8.41	0.11	--	8	NA	NA	
	5/6/2005	NA	8.1	8.15	0.05	--	8	NA	NA	
	9/12/2005*	NA	1	9.74	8.74	--	8	NA	NA	
	11/2/2005	NA	9.76	9.99	0.23	--	8	NA	NA	
	2/3/2006	NA	7.73	7.75	0.02	--	8	NA	NA	
	4/23/2006*	NA	7.52	7.52	0	--	8	NA	NA	
	8/18/2006	NA	8.03	8.04	0.01	--	8	NA	NA	
	11/2/2006	14.92	--	9.71	--	5.21	NA	NA	NA	
	2/1/2007	14.92	Sheen	9.84	0	5.08	NA	NA	NA	
	5/3/2007	14.92	--	--	--	--	NA	NA	NA	
	8/2/2007	14.92	10.29	10.38	0.09	4.54	NA	NA	NA	
	11/2/2007	14.92	--	--	--	--	NA	NA	NA	
	2/1/2008	14.92	9.79	9.95	0.16	4.97	NA	NA	NA	
	5/2/2008	14.92	10.09	10.23	0.14	4.69	NA	NA	NA	
	8/1/2008	14.92	10.8	11.3	0.5	3.62	NA	NA	NA	
	11/7/2008	14.92	10.5	11.2	0.7	3.72	NA	NA	NA	
	2/4/2009	14.92	10.29	10.83	0.54	4.09	NA	NA	NA	
	5/4/2009	14.92	9.83	11.44	1.61	3.48	NA	NA	NA	

**TABLE 2. Free Product Recovery System Groundwater Elevation and Free Product Data
Port of Oakland's Harbor Facilities Complex Site
555 - 651 Maritime Street, Oakland, California**

Recovery Well	Date Measured	Top of Casing (ft amsl)	Depth to Product (ft bTOC)	Depth to Water (ft bTOC)	Product Thickness (ft)	Groundwater Elevation (ft amsl)	Top of Screen (ft bgs)	Top of Screen** (ft amsl)	Submerged (1=Y/0=N)	Historically Submerged (%)
RW-4 (cont.)	8/5/2009	14.92	10.31	10.88	0.57	4.04	NA	NA	NA	
	11/4/2009	14.92	10.06	10.78	0.72	4.14	NA	NA	NA	
	2/3/2010	14.92	9.12	9.33	0.21	5.59	NA	NA	NA	
	5/5/2010	14.92	9.37	9.69	0.32	5.23	NA	NA	NA	
	8/11/2010	14.92	10.08	10.56	0.48	4.36	NA	NA	NA	
	11/3/2010	14.92	10.38	10.44	0.06	4.48	NA	NA	NA	
	01/12/11	14.92	9.12	9.20	0.08	5.78	NA	NA	NA	
	01/26/11	14.92	9.39	9.89	0.50	5.38	NA	NA	NA	
	02/10/11	14.92	9.52	10.54	1.02	5.09	NA	NA	NA	
	02/24/11	14.92	8.80	9.10	0.30	6.03	NA	NA	NA	
	03/09/11	14.92	8.93	8.96	0.03	5.98	NA	NA	NA	
	03/23/11	14.92	8.39	8.43	0.04	6.52	NA	NA	NA	
	04/06/11	14.92	8.46	8.50	0.04	6.45	NA	NA	NA	
	04/14/11	14.92	8.88	8.91	0.03	6.03	NA	NA	NA	
	05/04/11	14.92	9.13	9.17	0.04	5.78	NA	NA	NA	
	05/18/11	14.92	9.18	9.20	0.02	5.73	NA	NA	NA	
	06/07/11	14.92	NP	8.95	0.00	5.97	NA	NA	NA	
	06/21/11	14.92	9.33 ²	9.33	0.00	5.59	NA	NA	NA	
	09/26/11	14.92	9.82	10.41	0.59	4.92	NA	NA	NA	
	10/05/11	14.92	9.68	10.17	0.49	5.09	NA	NA	NA	
10/19/11	14.92	9.60	10.26	0.66	5.12	NA	NA	NA		
12/05/11	14.92	9.70	10.00	0.30	5.13	NA	NA	NA		
02/06/12	14.92	9.10	10.66	1.56	5.35	NA	NA	NA		
06/20/12	14.92	9.20	9.27	0.07	5.70	NA	NA	NA		
09/19/12	14.92	9.62	14.21	4.59	3.92	NA	NA	NA		
12/04/12	14.92	8.37	11.69	3.32	5.55	NA	NA	NA		
06/19/13	14.92	9.94	14.27	4.33	3.68	NA	NA	NA		
RW-5										NA
RW-6	5/11/2004	NA	NP	7.1	NP	--	8	NA	NA	
	10/5/2004*	NA	NP	8.04	NP	--	8	NA	NA	
	2/10/2005	NA	--	--	--	--	8	NA	NA	
	5/6/2005	NA	--	--	--	--	8	NA	NA	
	9/12/2005*	NA	NP	7.83	NP	--	8	NA	NA	
	11/2/2005	NA	--	--	--	--	8	NA	NA	
	2/3/2006	NA	NP	6.88	NP	--	8	NA	NA	
	4/23/2006*	NA	--	--	--	--	8	NA	NA	
	8/18/2006	NA	--	--	--	--	8	NA	NA	
	11/2/2006	14.79	--	--	--	--	NA	NA	NA	
	2/1/2007	14.79	--	--	--	--	NA	NA	NA	
	5/3/2007	14.79	--	--	--	--	NA	NA	NA	
	8/2/2007	14.79	--	--	--	--	NA	NA	NA	
	11/2/2007	14.79	--	--	--	--	NA	NA	NA	
	2/1/2008	14.79	8	8.17	0.17	6.62	NA	NA	NA	
	5/2/2008	14.79	--	--	--	--	NA	NA	NA	
	8/1/2008	14.79	9.05	9.3	0.25	5.49	NA	NA	NA	
	11/7/2008	14.79	--	--	--	--	NA	NA	NA	
	2/4/2009	14.79	--	--	--	--	NA	NA	NA	
	5/4/2009	14.79	8.45	8.94	0.49	5.85	NA	NA	NA	
	8/5/2009	14.79	--	--	--	--	NA	NA	NA	
	11/4/2009	14.79	--	--	--	--	NA	NA	NA	
	2/3/2010	14.79	sheen	6.6	0	8.19	NA	NA	NA	
	5/5/2010	14.79	--	--	--	--	NA	NA	NA	
	8/11/2010	14.79	--	--	--	--	NA	NA	NA	
	11/3/2010	14.79	6.41	9.54	3.13	5.25	NA	NA	NA	
	04/14/11	14.79	6.74	9.72	2.98	7.16	NA	NA	NA	
	05/18/11	14.79	6.78 ²	6.78	0.00	8.01	NA	NA	NA	
	06/07/11	14.79	7.38	7.47	0.09	7.38	NA	NA	NA	
	09/26/11	14.79	8.95	9.75	0.80	5.60	NA	NA	NA	
	10/05/11	14.79	8.66	9.09	0.43	6.00	NA	NA	NA	
02/06/12	14.79	8.47	12.01	3.54	5.26	NA	NA	NA		
06/20/12			Well not accessible.				NA	NA	NA	
09/19/12			Well not accessible.				NA	NA	NA	
12/04/12			Well not accessible.				NA	NA	NA	
06/19/13			Well not accessible.				NA	NA	NA	
RW-6										NA

**TABLE 2. Free Product Recovery System Groundwater Elevation and Free Product Data
Port of Oakland's Harbor Facilities Complex Site
555 - 651 Maritime Street, Oakland, California**

Recovery Well	Date Measured	Top of Casing (ft amsl)	Depth to Product (ft bTOC)	Depth to Water (ft bTOC)	Product Thickness (ft)	Groundwater Elevation (ft amsl)	Top of Screen (ft bgs)	Top of Screen** (ft amsl)	Submerged (1=Y/0=N)	Historically Submerged (%)
RW-6 (cont.)	5/11/2004	NA	NP	7.35	NP	--	8	NA	NA	
	10/5/2004*	NA	8.79	8.82	0.03	--	8	NA	NA	
	2/10/2005	NA	7.78	8.47	0.69	--	8	NA	NA	
	5/6/2005	NA	7.66	7.92	0.26	--	8	NA	NA	
	9/12/2005*	NA	8.26	8.79	0.53	--	8	NA	NA	
	11/2/2005	NA	8.52	8.81	0.29	--	8	NA	NA	
	2/3/2006	NA	7.35	7.39	0.04	--	8	NA	NA	
	4/23/2006*	NA	7.25	7.8	0.55	--	8	NA	NA	
	8/18/2006	NA	--	7.88	--	--	8	NA	NA	
	11/2/2006	15.75	8.75	8.84	0.09	6.91	NA	NA	NA	
	2/1/2007	15.75	8.85	8.89	0.04	6.86	NA	NA	NA	
	5/3/2007	15.75	8.82	8.92	0.1	6.83	NA	NA	NA	
	8/2/2007	15.75	9.1	9.48	0.38	6.27	NA	NA	NA	
	11/2/2007	15.75	8.89	9.9	1.01	5.85	NA	NA	NA	
	2/1/2008	15.75	8.24	8.41	0.17	7.34	NA	NA	NA	
	5/2/2008	15.75	8.33	9.17	0.84	6.58	NA	NA	NA	
	8/1/2008	15.75	8.75	10.3	1.55	5.45	NA	NA	NA	
	11/7/2008	15.75	9	10.5	1.5	5.25	NA	NA	NA	
	2/4/2009	15.75	9	10.98	1.98	4.77	NA	NA	NA	
	5/4/2009	15.75	8.45	10.06	1.61	5.69	NA	NA	NA	
	8/5/2009	15.75	8.73	10.93	2.2	4.82	NA	NA	NA	
	11/4/2009	15.75	8.93	10.92	1.99	4.83	NA	NA	NA	
	2/3/2010	15.75	8.55	9.81	1.26	5.94	NA	NA	NA	
	5/5/2010	15.75	8.62	8.94	0.32	6.81	NA	NA	NA	
	8/11/2010	15.75	8.78	10.14	1.36	5.61	NA	NA	NA	
	11/3/2010	15.75	8.84	10.61	1.77	5.14	NA	NA	NA	
	01/12/11	15.75	8.51	9.68	1.17	6.89	NA	NA	NA	
	01/26/11	15.75	8.65	9.55	0.90	6.83	NA	NA	NA	
	02/10/11	15.75	8.44	9.74	1.30	6.92	NA	NA	NA	
	02/24/11	15.75	8.15	9.82	1.67	7.10	NA	NA	NA	
	03/09/11	15.75	8.25	9.37	1.12	7.16	NA	NA	NA	
	03/23/11	15.75	8.18	8.96	0.78	7.34	NA	NA	NA	
	04/06/11	15.75	8.19	8.95	0.76	7.33	NA	NA	NA	
04/20/11	15.75	8.43	8.54	0.11	7.29	NA	NA	NA		
05/04/11	15.75	8.51	8.62	0.11	7.21	NA	NA	NA		
05/18/11	15.75	8.53	8.70	0.17	7.17	NA	NA	NA		
06/07/11	15.75	8.82	9.05	0.23	6.86	NA	NA	NA		
06/21/11	15.75	8.89	9.20	0.31	6.77	NA	NA	NA		
09/26/11	15.75	8.86	10.20	1.34	6.49	NA	NA	NA		
10/05/11	15.75	9.05	9.72	0.67	6.50	NA	NA	NA		
10/19/11	15.75	8.99	10.16	1.17	6.41	NA	NA	NA		
12/05/12	15.75	9.05	10.62	1.57	6.23	NA	NA	NA		
02/06/12	15.75	8.95	10.82	1.87	6.24	NA	NA	NA		
06/20/12	15.75	8.92	9.99	1.07	6.51	NA	NA	NA		
09/19/12	15.75	9.10	10.83	1.73	6.13	NA	NA	NA		
12/04/12	15.75	8.83	10.79	1.96	6.33	NA	NA	NA		
06/19/13	15.75	8.86	10.35	1.49	6.44	NA	NA	NA		
RW-7										NA
	5/11/2004	NA	NP	7.2	NP	--	8	NA	NA	
	10/5/2004*	NA	8.41	8.67	0.26	--	8	NA	NA	
	2/10/2005	NA	7.51	7.7	0.19	--	8	NA	NA	
	5/6/2005	NA	7.28	7.42	0.14	--	8	NA	NA	
	9/12/2005*	NA	7.85	8.04	0.19	--	8	NA	NA	
	11/2/2005	NA	8.05	8.21	0.16	--	8	NA	NA	
	2/3/2006	NA	7.02	7.09	0.07	--	8	NA	NA	
	4/23/2006*	NA	6.85	6.86	0.01	--	8	NA	NA	
	8/18/2006	NA	7.4	7.5	0.1	--	8	NA	NA	
	11/2/2006	15.02	--	8.2	--	6.82	NA	NA	NA	
	2/1/2007	15.02	NP	8.28	NP	6.74	NA	NA	NA	
	5/3/2007	15.02	--	--	--	--	NA	NA	NA	
	8/2/2007	15.02	--	--	--	--	NA	NA	NA	
	11/2/2007	15.02	8.32	9.24	0.92	5.78	NA	NA	NA	
	2/1/2008	15.02	8.12	8.45	0.33	6.57	NA	NA	NA	
	5/2/2008	15.02	7.75	7.81	0.06	7.21	NA	NA	NA	
8/1/2008	15.02	8.17	9.4	1.23	5.62	NA	NA	NA		

**TABLE 2. Free Product Recovery System Groundwater Elevation and Free Product Data
Port of Oakland's Harbor Facilities Complex Site
555 - 651 Maritime Street, Oakland, California**

Recovery Well	Date Measured	Top of Casing (ft amsl)	Depth to Product (ft bTOC)	Depth to Water (ft bTOC)	Product Thickness (ft)	Groundwater Elevation (ft amsl)	Top of Screen (ft bgs)	Top of Screen** (ft amsl)	Submerged (1=Y/0=N)	Historically Submerged (%)
RW-7 (cont.)	11/7/2008	15.02	8.45	9.2	0.75	5.82	NA	NA	NA	
	2/4/2009	15.02	8.31	10.92	2.61	4.1	NA	NA	NA	
	5/4/2009	15.02	7.2	7.94	0.74	7.08	NA	NA	NA	
	8/5/2009	15.02	8.26	10.26	2	4.76	NA	NA	NA	
	11/4/2009	15.02	8.02	10.51	2.49	4.51	NA	NA	NA	
	2/3/2010	15.02	7.85	8.33	0.48	6.69	NA	NA	NA	
	5/5/2010	15.02	7.95	8.23	0.28	6.79	NA	NA	NA	
	8/11/2010	15.02	7.87	9.85	1.98	5.17	NA	NA	NA	
	11/3/2010	15.02	7.65	9.48	1.83	5.54	NA	NA	NA	
	01/12/11	15.02	7.86	7.91	0.05	7.15	NA	NA	NA	
	01/26/11	15.02	7.55	7.64	0.09	7.44	NA	NA	NA	
	02/10/11	15.02	7.50	7.68	0.18	7.47	NA	NA	NA	
	02/24/11	15.02	7.82	8.92	1.10	6.87	NA	NA	NA	
	03/09/11	15.02	7.42	7.53	0.11	7.57	NA	NA	NA	
	03/23/11	15.02	NP	7.24	0.00	7.78	NA	NA	NA	
	04/06/11	15.02	7.73	7.73	0.00	7.29	NA	NA	NA	
	04/20/11	15.02	7.54	7.56	0.02	7.47	NA	NA	NA	
	05/04/11	15.02	7.68	7.74	0.06	7.32	NA	NA	NA	
	05/18/11	15.02	7.35 ²	7.35	0.00	7.67	NA	NA	NA	
	06/07/11	15.02	7.98 ²	7.98	0.00	7.04	NA	NA	NA	
	06/21/11	15.02	8.07	8.09	0.00	6.93	NA	NA	NA	
	09/26/11	15.02	8.29	8.90	0.61	6.55	NA	NA	NA	
	10/05/11	15.02	8.19	8.45	0.26	6.75	NA	NA	NA	
10/19/11	15.02	8.24	8.90	0.66	6.58	NA	NA	NA		
12/05/11	15.02	8.26	9.77	1.51	6.31	NA	NA	NA		
02/06/12	15.02	8.18	9.86	1.68	6.34	NA	NA	NA		
06/20/12	15.02	8.35	8.41	0.06	6.65	NA	NA	NA		
09/19/12	15.02	8.45	11.44	2.99	5.67	NA	NA	NA		
12/04/12	15.02	8.25	8.33	0.08	6.75	NA	NA	NA		
06/19/13	15.02	8.25	13.75	5.50	5.12	NA	NA	NA		
RW-8										NA
RW-8	5/11/2004	NA	NP	7.65	NP	--	9	NA	NA	
	10/5/2004*	NA	9.09	9.17	0.08	--	9	NA	NA	
	2/10/2005	NA	8.54	8.55	0.01	--	9	NA	NA	
	5/6/2005	NA	8.22	8.23	0.01	--	9	NA	NA	
	9/12/2005*	NA	8.62	9.26	0.64	--	9	NA	NA	
	11/2/2005	NA	8.81	9.42	0.61	--	9	NA	NA	
	2/3/2006	NA	7.92	8	0.08	--	9	NA	NA	
	4/23/2006*	NA	7.63	7.63	0	--	9	NA	NA	
	8/18/2006	NA	--	8.21	--	--	9	NA	NA	
	11/2/2006	15.91	9.04	9.06	0.02	6.85	NA	NA	NA	
	2/1/2007	15.91	9.15	9.23	0.08	6.68	NA	NA	NA	
	5/3/2007	15.91	9.25	9.31	0.06	6.6	NA	NA	NA	
	8/2/2007	15.91	9.25	9.57	0.32	6.34	NA	NA	NA	
	11/2/2007	15.91	9.4	9.71	0.31	6.2	NA	NA	NA	
	2/1/2008	15.91	9.71	10	0.29	5.91	NA	NA	NA	
	5/2/2008	15.91	8.89	9.16	0.27	6.75	NA	NA	NA	
	8/1/2008	15.91	9.35	10.85	1.5	5.06	NA	NA	NA	
	11/7/2008	15.91	9.3	10.8	1.5	5.11	NA	NA	NA	
	2/4/2009	15.91	9.3	11.16	1.86	4.75	NA	NA	NA	
	5/4/2009	15.91	9.23	9.93	0.7	5.98	NA	NA	NA	
	8/5/2009	15.91	9.6	10.9	1.3	5.01	NA	NA	NA	
	11/4/2009	15.91	9.54	10.41	0.87	5.5	NA	NA	NA	
	2/3/2010	15.91	9.26	9.84	0.58	6.07	NA	NA	NA	
	5/5/2010	15.91	9.14	9.33	0.19	6.58	NA	NA	NA	
	8/11/2010	15.91	9.2	9.76	0.56	6.15	NA	NA	NA	
	11/3/2010	15.91	9.53	10.49	0.96	5.42	NA	NA	NA	
	01/12/11	15.91	9.07	9.21	0.14	6.80	NA	NA	NA	
	01/26/11	15.91	9.23	9.31	0.08	6.66	NA	NA	NA	
	02/10/11	15.91	9.13	9.33	0.20	6.72	NA	NA	NA	
	02/24/11	15.91	8.86	9.23	0.37	6.94	NA	NA	NA	
	03/09/11	15.91	8.78	9.01	0.23	7.06	NA	NA	NA	
03/23/11	15.91	8.42	8.70	0.28	7.41	NA	NA	NA		
04/06/11	15.91	8.55	8.80	0.25	7.29	NA	NA	NA		
04/20/11	15.91	8.92	9.14	0.22	6.92	NA	NA	NA		
05/04/11	15.91	9.04	9.20	0.16	6.82	NA	NA	NA		

**TABLE 2. Free Product Recovery System Groundwater Elevation and Free Product Data
Port of Oakland's Harbor Facilities Complex Site
555 - 651 Maritime Street, Oakland, California**

Recovery Well	Date Measured	Top of Casing (ft amsl)	Depth to Product (ft bTOC)	Depth to Water (ft bTOC)	Product Thickness (ft)	Groundwater Elevation (ft amsl)	Top of Screen (ft bgs)	Top of Screen** (ft amsl)	Submerged (1=Y/0=N)	Historically Submerged (%)
	05/18/11	15.91	8.85	9.10	0.25	6.99	NA	NA	NA	
	06/07/11	15.91	10.23	10.34	0.11	5.65	NA	NA	NA	
	06/21/11	15.91	9.27	9.41	0.14	6.60	NA	NA	NA	
	09/26/11	15.91	9.23	9.62	0.39	6.56	NA	NA	NA	
	10/05/11	15.91	9.28	9.40	0.12	6.59	NA	NA	NA	
	10/19/11	15.91	9.54	9.77	0.23	6.30	NA	NA	NA	
	12/05/11	15.91	9.62	10.19	0.57	6.12	NA	NA	NA	
	02/06/12	15.91	9.21	10.22	1.01	6.40	NA	NA	NA	
	06/20/12	15.91	9.36	10.28	0.92	6.27	NA	NA	NA	
	09/19/12	15.91	10.55	11.45	0.90	5.09	NA	NA	NA	
	12/04/12	15.91	9.29	11.32	2.03	6.01	NA	NA	NA	
06/19/13	15.91	9.42	11.11	1.69	5.98	NA	NA	NA		
RW-9										NA
RW-9 (cont.)	5/11/2004	NA	NP	9.4	NP	--	9	NA	NA	
	10/5/2004*	NA	10.24	10.26	0.02	--	9	NA	NA	
	2/10/2005	NA	--	--	--	--	9	NA	NA	
	5/6/2005	NA	--	--	--	--	9	NA	NA	
	9/12/2005*	NA	NP	10.27	NP	--	9	NA	NA	
	11/2/2005	NA	NP	10.42	NP	--	9	NA	NA	
	2/3/2006	NA	NP	9.21	NP	--	9	NA	NA	
	4/23/2006*	NA	--	--	--	--	9	NA	NA	
	8/18/2006	NA	--	--	--	--	9	NA	NA	
	11/2/2006	16.57	--	--	--	--	NA	NA	NA	
	2/1/2007	16.57	--	--	--	--	NA	NA	NA	
	5/3/2007	16.57	--	--	--	--	NA	NA	NA	
	8/2/2007	16.57	--	--	--	--	NA	NA	NA	
	11/2/2007	16.57	--	--	--	--	NA	NA	NA	
	2/1/2008	16.57	10.71	11.05	0.34	5.52	NA	NA	NA	
	5/2/2008	16.57	8.34	9.41	1.07	7.16	NA	NA	NA	
	8/1/2008	16.57	10.05	11.25	1.2	5.32	NA	NA	NA	
	11/7/2008	16.57	9.9	11.1	1.2	5.47	NA	NA	NA	
	2/4/2009	16.57	9.88	11.7	1.82	4.87	NA	NA	NA	
	5/4/2009	16.57	9.87	10.64	0.77	5.93	NA	NA	NA	
	8/5/2009	16.57	9.95	10.59	0.64	5.98	NA	NA	NA	
	11/4/2009	16.57	9.91	10.5	0.59	6.07	NA	NA	NA	
	2/3/2010	16.57	9.46	9.52	0.06	7.05	NA	NA	NA	
	5/5/2010	16.57	9.57	9.63	0.06	6.94	NA	NA	NA	
	8/11/2010	16.57	9.78	10.02	0.24	6.55	NA	NA	NA	
	11/3/2010	16.57	9.86	10.16	0.3	6.41	NA	NA	NA	
	01/12/11	16.57	9.26	9.45	0.19	7.25	NA	NA	NA	
	01/26/11	16.57	9.32	9.53	0.21	7.19	NA	NA	NA	
	02/10/11	16.57	9.42	9.63	0.21	7.09	NA	NA	NA	
	02/24/11	16.57	9.24	9.43	0.19	7.27	NA	NA	NA	
	03/09/11	16.57	9.16	9.35	0.19	7.35	NA	NA	NA	
	03/23/11	16.57	9.07	9.23	0.16	7.45	NA	NA	NA	
	04/06/11	16.57	9.00	9.16	0.16	7.52	NA	NA	NA	
	04/20/11	16.57	9.10	9.29	0.19	7.41	NA	NA	NA	
05/04/11	16.57	9.19	9.40	0.21	7.32	NA	NA	NA		
05/18/11	16.57	9.26	9.46	0.20	7.25	NA	NA	NA		
06/07/11	16.57	9.35	9.56	0.21	7.16	NA	NA	NA		
06/21/11	16.57	9.30	9.50	0.20	7.21	NA	NA	NA		
09/26/11	16.57	9.67	9.85	0.18	6.85	NA	NA	NA		
10/05/11	16.57	9.70	9.81	0.11	6.84	NA	NA	NA		
10/19/11	16.57	9.67	9.78	0.11	6.87	NA	NA	NA		
12/05/11	16.57	9.75	10.14	0.39	6.70	NA	NA	NA		
02/06/12	16.57	9.88	10.37	0.49	6.54	NA	NA	NA		
06/20/12	16.57	9.49	10.40	0.91	6.81	NA	NA	NA		
09/19/12	16.57	9.81	11.04	1.23	6.39	NA	NA	NA		
12/04/12	16.57	9.50	11.06	1.56	6.60	NA	NA	NA		
06/19/13	16.57	9.68	10.76	1.08	6.57	NA	NA	NA		

Notes:

From April 2004 to November 2010, only data from the second month of each quarter reported in this table. All available data provided as attachment
ft amsl = feet above mean sea level

**TABLE 2. Free Product Recovery System Groundwater Elevation and Free Product Data
Port of Oakland's Harbor Facilities Complex Site
555 - 651 Maritime Street, Oakland, California**

Recovery Well	Date Measured	Top of Casing (ft amsl)	Depth to Product (ft bTOC)	Depth to Water (ft bTOC)	Product Thickness (ft)	Groundwater Elevation (ft amsl)	Top of Screen (ft bgs)	Top of Screen** (ft amsl)	Submerged (1=Y/0=N)	Historically Submerged (%)
---------------	---------------	-------------------------	----------------------------	--------------------------	------------------------	---------------------------------	------------------------	---------------------------	---------------------	----------------------------

ft bTOC = feet below top of casing

ft bgs = feet below ground surface

NP = no product detected with the interface probe

* = data from second month of quarter not available, first or third month shown instead

** = Ground elevation assumed to be approximately equal to casing elevation at time of install (top of screen elevation does not change when grade elevation changes)

NA = Not Available

-- = not measured/not applicable

**TABLE 3. Historical Groundwater Elevation and Free Product Data
Former 2225 7th Street Wells
Port of Oakland's Harbor Facilities Complex Site
555 - 651 Maritime Street, Oakland, California**

Monitoring Well	Date Measured	Top of Casing (ft amsl)	Depth to Water (ft bTOC)	Groundwater Elevation (ft amsl)	Top of Screen (ft bgs)	Top of Screen** (ft amsl)	Submerged (1=Y/0=N)	Historically Submerged (%)
MW-1								4%
	01/15/93	13.72	5.21	8.51	5	8.72	0	
	09/12/94	13.72	6.37	7.35	5	8.72	0	
	11/30/94	13.72	5.76	7.96	5	8.72	0	
	03/29/95	13.72	4.57	9.15	5	8.72	1	
	05/25/95	13.72	5.14	8.58	5	8.72	0	
	06/21/95	13.72	5.41	8.31	5	8.72	0	
	06/23/95	13.72	5.44	8.28	5	8.72	0	
	11/20/95	13.72	6.28	7.44	5	8.72	0	
	12/27/95	13.72	5.86	7.86	5	8.72	0	
	03/25/96	13.72	5.21	8.51	5	8.72	0	
	06/26/96	13.72	5.58	8.14	5	8.72	0	
	10/14/96	13.72	6.22	7.50	5	8.72	0	
	03/19/97	13.72	5.48	8.24	5	8.72	0	
	06/26/00	13.72	5.19	8.53	5	8.72	0	
	09/06/00	13.72	5.62	8.10	5	8.72	0	
	12/19/00	13.72	5.57	8.15	5	8.72	0	
	04/03/01	13.72	5.03	8.69	5	8.72	0	
	07/10/01	13.72	5.57	8.15	5	8.72	0	
	12/12/01	13.72	5.60	8.12	5	8.72	0	
	01/22/02	13.72	5.19	8.53	5	8.72	0	
	03/08/02	13.72	5.17	8.55	5	8.72	0	
	06/13/02	13.72	5.60	8.12	5	8.72	0	
	09/26/02	13.72	6.05	7.67	5	8.72	0	
MW-2								0%
	01/15/93	13.80	6.21	7.59	5	8.8	0	
	09/12/94	13.80	6.47	7.33	5	8.80	0	
	11/30/94	13.80	6.34	7.46	5	8.80	0	
	03/29/95	13.80	5.51	8.29	5	8.80	0	
	05/25/95	13.80	5.60	8.20	5	8.80	0	
	06/21/95	13.80	5.72	8.08	5	8.80	0	
	06/23/95	13.80	5.72	8.08	5	8.80	0	
	09/28/95	13.80	6.15	7.65	5	8.80	0	
	11/20/95	13.80	6.42	7.38	5	8.80	0	
	12/27/95	13.80	6.31	7.49	5	8.80	0	
	03/25/96	13.80	5.74	8.06	5	8.80	0	
	06/26/96	13.80	5.85	7.95	5	8.80	0	
	10/14/96	13.80	6.36	7.44	5	8.80	0	
	03/19/97	13.80	5.90	7.90	5	8.80	0	
	06/26/00	13.80	5.37	8.43	5	8.80	0	
	09/06/00	13.80	5.62	8.18	5	8.80	0	
	12/19/00	13.80	5.81	7.99	5	8.80	0	
	04/03/01	13.80	5.38	8.42	5	8.80	0	
	07/10/01	13.80	5.80	8.00	5	8.80	0	
	12/12/01	13.80	10.00	3.80	5	8.80	0	
	01/22/02	13.80	5.45	8.35	5	8.80	0	
	03/08/02	13.80	5.49	8.31	5	8.80	0	
	06/13/02	13.80	5.79	8.01	5	8.80	0	
	09/26/02	13.80	8.15	5.65	5	8.80	0	
MW-3								0%
	01/15/93	15.06	6.44	8.62	5	10.06	0	
	09/12/94	15.06	7.35	7.71	5	10.06	0	

**TABLE 3. Historical Groundwater Elevation and Free Product Data
Former 2225 7th Street Wells
Port of Oakland's Harbor Facilities Complex Site
555 - 651 Maritime Street, Oakland, California**

Monitoring Well	Date Measured	Top of Casing (ft amsl)	Depth to Water (ft bTOC)	Groundwater Elevation (ft amsl)	Top of Screen (ft bgs)	Top of Screen** (ft amsl)	Submerged (1=Y/0=N)	Historically Submerged (%)
	11/30/94	15.06	7.12	7.94	5	10.06	0	
	03/29/95	15.06	6.31	8.75	5	10.06	0	
	05/25/95	15.06	6.75	8.31	5	10.06	0	
	06/21/95	15.06	6.87	8.19	5	10.06	0	
	06/23/95	15.06	6.88	8.18	5	10.06	0	
	09/28/95	15.06	7.28	7.78	5	10.06	0	
	11/20/95	15.06	7.51	7.55	5	10.06	0	
	12/27/95	15.06	7.20	7.86	5	10.06	0	
	03/25/96	15.06	6.64	8.42	5	10.06	0	
	06/26/96	15.06	6.98	8.08	5	10.06	0	
	10/14/96	15.06	7.47	7.59	5	10.06	0	
	03/19/97	15.06	6.99	8.07	5	10.06	0	
	06/26/00	15.06	6.82	8.24	5	10.06	0	
	09/06/00	15.06	6.82	8.24	5	10.06	0	
	12/19/00	15.06	7.10	7.96	5	10.06	0	
	04/03/01	15.06	6.66	8.40	5	10.06	0	
	07/10/01	15.06	7.00	8.06	5	10.06	0	
	12/12/01	15.06	7.04	8.02	5	10.06	0	
	01/22/02	15.06	6.67	8.39	5	10.06	0	
	03/08/02	15.06	6.86	8.20	5	10.06	0	
	06/13/02	15.06	7.00	8.06	5	10.06	0	
	09/26/02	15.06	7.40	7.66	5	10.06	0	

Notes:

ft amsl = feet above mean sea level

ft bTOC = feet below top of casing

ft bgs = feet below ground surface

Depth to Product data not available



Attachment 7

Groundwater analytical results

**TABLE 1. Groundwater Analytical Results Summary
Port of Oakland's Harbor Facilities Complex Site
555 - 651 Maritime Street, Oakland, California**

Monitoring Well	Date Sampled	Concentration (µg/L)							
		TPH-G	TPH-D	TPH-MO	Benzene	Toluene	Ethyl-benzene	Total Xylenes	MTBE
MW-1									
	05/22/00	3,600	41,000	<3,000	100	13 ⁸	2.9	2.05	3.2 ⁸
	12/08/09	1,400	1,200 ²	<300	120	2.9	1.8	3.0	<1.0
	06/22/11	1,100 ²	890 ²⁴	<300 ²⁴	46	1.9	2.6	2.0	<0.5
	06/19/13	1,600 ²	3,100	<300	18	2.2	4.4	1.8	<0.5
MW-2									
	05/27/94	87	470	NA	<0.5	<0.5	<0.5	<0.5	NA
	03/29/95	<50	110	1,400	<0.4	<0.3	<0.3	<0.4	NA
	09/06/95	<50	NA	NA	<0.4	<0.3	<0.3	<0.4	NA
	01/08/96	<50	<50	1200	<0.4	<0.3	<0.3	<0.4	NA
	04/04/96	<50	160	320	<0.5	<0.5	<0.5	<1.0	NA
	07/10/96	<50	120	1400	<0.4	<0.3	<0.3	<0.4	NA
	12/03/96	<50	230 ^{1,2}	<250	<0.5	<0.5	<0.5	<1.0	NA
	03/28/97	<50	714	<250	<0.5	<0.5	<0.5	<1.0	NA
	06/13/97	51	<50	<250	<0.5	<0.5	<0.5	<1.0	NA
	09/18/97	82	<50	<250	0.56	<0.5	<0.5	<1.0	NA
	12/31/97	<50	<47	<280	1.4	<0.5	<0.5	<1.0	NA
	04/13/98	<50	<50	<300	<0.5	<0.5	<0.5	<1.0	NA
	11/06/98	<50	<50	<300	<0.5	<0.5	<0.5	<0.5	<2.0
	03/19/99	<50	<50	<300	<0.5	<0.5	<0.5	<0.5	<2.0
	06/24/99	<50	<50	<300	<0.5	<0.5	<0.5	<0.5	<2.0
	09/28/99	<50	<50	<300	<0.5	<0.5	<0.5	<0.5	<2.0
	11/12/99	<50	120 ^{2,6}	<300	<0.5	<0.5	<0.5	<0.5	6.3 ^{8,9}
	02/11/00	<50	<50	<300	5.4	<0.5	<0.5	<0.5	<2
	05/22/00	<50	<50	<300	<0.5	<0.5	<0.5	<0.5	<2
	09/06/00	<50	<50	<300	0.76 ⁸	<0.5	<0.5	<0.5	<0.5 ¹⁰
	12/19/00	200 ^{3,11}	<50	<300	39	1.8	<0.5	2.6	<0.5 ^{10,12}
	02/21/01	<50	<50	<300	<0.5	<0.5	<0.5	<0.5	<2.0
	07/10/01	<50	<50	<300	<0.5	<0.5	<0.5	<0.5	<2.0
	12/05/01	<50	<50	<300	4.4	<0.5	<0.5	<0.5	5.0 ¹⁴
	03/08/02	<50	<50	<500	<0.5	<0.5	<0.5	<0.5	<5.0
	06/13/02	62 ¹⁵	<57	<570	<0.5	<0.5	<0.5	<0.5	<5.0
	09/26/02	69 ²	<50	<500	1.8	<0.5	<0.5	<0.5	<5.0
	12/12/02	<50	<50	<300	0.98	<0.5	<0.5	<0.5	<2.0
	03/17/03	<50	<50	<300	<0.5	<0.5	<0.5	<0.5	<2.0
	06/18/03	<50	<50	<300	<0.5	<0.5	<0.5	<0.5	<2.0
	09/03/03	<50	<50	<300	3.2	<0.5	<0.5	<0.5	<2.0
	11/26/03	<50	<50	<300	3	<0.5	<0.5	<0.5	<2.0
	03/05/04	<50	<50	<300	<0.5	<0.5	<0.5	<0.5	<2.0
	06/02/04	<50	<50	<300	<0.5	<0.5	<0.5	<0.5	<2.0
	09/03/04	<50	<50	<300	<0.5	<0.5	<0.5	<0.5	<2.0
	12/16/04	<50	96 ^{6,15}	<300	<0.5	<0.5	<0.5	<0.5	<2.0
	03/29/05	<50	<50	<300	<0.5	<0.5	<0.5	<0.5	<2.0

**TABLE 1. Groundwater Analytical Results Summary
Port of Oakland's Harbor Facilities Complex Site
555 - 651 Maritime Street, Oakland, California**

Monitoring Well	Date Sampled	Concentration (µg/L)							
		TPH-G	TPH-D	TPH-MO	Benzene	Toluene	Ethyl-benzene	Total Xylenes	MTBE
MW-2 (cont)	08/10/05	<50	<50	<250	<0.5	<0.5	<0.5	<0.5	<0.5
	09/29/05	<50	<50	<250	<0.5	<0.5	<0.5	<0.5	<0.5
	12/21/05	<50	<50	<300	<0.5	<0.5	<0.5	<0.5	<0.5
	03/24/06	<50	<50	<300	<0.5	<0.5	<0.5	<0.5	<0.5
	07/28/06	<50	<50	<300	<0.5	<0.5	<0.5	<0.5	<0.5
	11/29/06	<50	<50	<300	<0.5	<0.5	<0.5	<0.5	<0.5
	06/01/07	<50	<50	<300	<0.5	<0.5	<0.5	<0.5	<0.5
	11/14/07	<50	<50	<300	<0.5	<0.5	<0.5	<0.5	<0.5
	06/05/08	<50	<50	<300	<0.5	<0.5	<0.5	<0.5	<0.5
	12/18/08	390 ²	840	<300	1.1	<0.5	0.9	<0.5	<0.5
	03/04/09	<50	<50	<300	<0.5	<0.5	<0.5	<0.5	<0.5
	04/01/09	<50	<50	<300	<0.5	<0.5	<0.5	<0.5	<0.5
	06/17/09	<50	<50	<300	<0.5	<0.5	<0.5	<0.5	<0.5
	12/09/09	<50	<50	<300	<0.5	<0.5	<0.5	<0.5	<0.5
	06/17/10	<50	220 ²	<300	<0.5	<0.5	<0.5	<0.5	<0.5
	12/15/10	<50	<50	<300	<0.5	<0.5	<0.5	<0.5	<0.5
	06/22/11	<50	<50	<300 ^{2,3}	<0.5	<0.5	<0.5	<0.5	<0.5
	09/26/11	<50	<50 ²⁴	<300 ²⁴	<0.5	<0.5	<0.5	<0.5	<0.5
	06/19/12	<50	<53	<320	<0.5	<0.5	<0.5	<0.5	<0.5
	12/04/12	<50	<53	<320	<0.5	<0.5	<0.5	<0.5	<0.5
	06/19/13	<50	<51	<310	<0.5	<0.5	<0.5	<0.5	<0.5
MW-3									
	Not sampled due to the presence of free-phase product								
MW-4									
	09/11/95	150	<200	500	23	<0.3	<0.3	<0.4	NA
	01/08/96	790	90	400	170	1.2	0.6	0.6	NA
	04/04/96	1,100	180	300	320	1.6	1.1	1.2	NA
	07/10/96	1,200	120	300	470	1.5	0.8	0.8	NA
	12/03/96	990	220 ^{1,2}	<250	350	3.3	1.3	1.3	NA
	03/28/97	440 ²	<50	<250	190	1.2	0.64	<1.0	NA
	06/13/97	1,300	92 ⁵	<250	500	5.5	3.4	2.8	NA
	09/18/97	1,300	150	<250	550	4.9	2.1	2.00	NA
	12/31/97	73 ^{1,2,3}	<47	<280	110 ¹	1.0 ¹	<0.5	<1.0	NA
	04/13/98	150 ^{2,3}	<50	<300	520	2.9	<2.5	<5.0	NA
	11/06/98	<50	<50	<300	250	1.7	<1.0	<1.0	<4
	03/19/99	81	<50	<300	250	<1	1.2	<1.0	<4
Dup.	06/24/99	190	<50	<300	360	1.4	2.2	1.0	24
	09/28/99	750 ^{3,5}	63 ^{3,5}	<300	280	1.5	<1.0	<1.0	<4
	11/12/99	330 ³	840 ²	<300	740	<2.5	<2.5	<2.5	42 ⁹
	02/11/00	200 ²	<50	<300	58	0.73	<0.5	<0.5	4.4 ⁸
	05/22/00	240	<50	<300	500	<2.5	<2.5	<2.5	17
	09/06/00	530 ^{2,3}	<50	<300	190	0.93	0.6	0.57	<0.5 ¹⁰
	12/19/00	960 ^{3,11}	70 ⁵	<300	420	<2.5	<2.5	<2.5	<0.5 ^{10,12}

**TABLE 1. Groundwater Analytical Results Summary
Port of Oakland's Harbor Facilities Complex Site
555 - 651 Maritime Street, Oakland, California**

Monitoring Well	Date Sampled	Concentration (µg/L)							
		TPH-G	TPH-D	TPH-MO	Benzene	Toluene	Ethyl-benzene	Total Xylenes	MTBE
MW-4 (cont)	12/19/00	1,200 ^{3,11}	<50	<300	440	<2.5	<2.5	<2.5	<0.5 ^{10,12}
	02/21/01	450 ¹³	<50	<300	120	<0.5	<0.5	<0.5	<0.5 ¹⁰
	07/10/01	<250	110 ^{2,13}	<300	620	2.6	2.9	<2.5	<0.5 ^{8,10}
	12/05/01	180	<50	<300	61	<0.5	<0.5	<0.5	3.8 ¹⁴
	03/08/02	490 ²	54 ²	<500	180	<2.5	<2.5	<2.5	<25
	06/13/02	830 ²	<50	<500	250	<5.0	<5.0	<5.0	<50
Dup.	06/13/02	820 ²	<56	<560	240	<5.0	<5.0	<5.0	<50
	09/26/02	390 ²	57	<500	150	2.1	<1.0	<1.0	<10
Dup.	09/26/02	500 ²	<50 ¹⁶	<500 ¹⁶	200	1.5	<1.0	<1.0	<10
	12/12/02	580	<50	<300	240	1.4	0.56	<0.5	<2.0
Dup.	12/12/02	2,400	<50	<300	680	5.0	2.3	1.4	<2.0
	03/17/03	130 ¹⁵	<50	<300	320 ¹⁷	<0.5	<0.5	<0.5	<0.5 ¹⁰
Dup.	03/17/03	82 ¹⁵	<50	<300	190	0.64 ¹⁷	0.56	0.53	<0.5 ¹⁰
	06/18/03	360 ^{11, 15}	<50	<300	150	<0.5	<0.5	<0.5	<2.0
Dup.	06/18/03	330 ^{11, 15}	<50	<300	140	<0.5	<0.5	<0.5	<2.0
	09/03/03	140 ^{11, 15}	<50	<300	240	1.3	<0.5	<0.5	<2.0
Dup.	09/03/03	83 ^{11, 15}	<50	<300	130	0.58 ¹⁷	<0.5	<0.5	<2.0
	11/26/03	160 ¹⁵	68 ¹⁵	<300	320	0.91 ¹⁷	<0.5	0.53	<2.0
Dup.	11/26/03	120 ¹⁵	<50	<300	210	0.66 ¹⁷	<0.5	<0.5	<2.0
	03/05/04	90 ¹¹	<50	<300	190	1.1	0.55	0.50 ¹⁷	23 ^{14,17} , <0.5 ¹⁰
Dup.	03/05/04	84 ¹¹	<50	<300	180	0.81	<0.5	<0.5	21 ^{14,17} , <0.5 ¹⁰
	06/02/04	620 ¹³	<50	<300	210	0.55 ¹⁷	<0.5	<0.5	<2.0
Dup.	06/02/04	400 ¹³	<50	<300	130	<0.5	<0.5	<0.5	<2.0
	09/03/04	780 ^{13, 15}	<50	<300	<0.5	1.0 ¹⁷	<0.5	0.57	<2.0
Dup.	09/03/04	370 ^{13, 15}	<50	<300	<0.5	<0.5	<0.5	<0.5	<2.0
	12/16/04	840	<50	<300	290	1.3 ¹⁷	0.69	0.75	<2.0
Dup.	12/16/04	670	<50	<300	230	1.3 ¹⁷	<0.5	<0.5	<2.0
	03/29/05	440 ¹³	<50	<300	140	0.57	<0.5	<0.5	<2.0
Dup.	03/29/05	540 ¹³	<50	<300	170	0.72	<0.5	<0.5	<2.0
	08/10/05	500 ¹⁸	<50	<250	180	<2.5	<2.5	<2.5	<2.5
	09/29/05	360 ¹⁸	59 ²⁰	<250	160	<5.0	<5.0	<5.0	<5.0
Dup.	09/29/05	420 ¹⁸	<50	<250	150	<5.0	<5.0	<5.0	<5.0
	12/21/05	110	<50	<300	76	<0.5	<0.5	<0.5	<0.5
Dup.	12/21/05	160	<50	<300	76	<0.5	<0.5	<0.5	<0.5
	03/24/06	420	51	<300	120	0.8	<0.7	<0.7	<0.7
Dup.	03/24/06	440	<50	<300	130	<0.7	<0.7	<0.7	<0.7
	08/04/06	560	92 ²	<300	160	<1.3	4.3	<1.3	<1.3
Dup.	08/04/06	590	100 ²	<300	150	<1.3	4.5	<1.3	<1.3
	11/29/06	300	<50	<300	42	<0.7	1.0	<0.7	<0.7
Dup.	11/29/06	300	<50	<300	60	<0.7	<0.7	<0.7	<0.7
	06/01/07	100 ^{13, 15}	<50	<300	10	<0.5	<0.5	<0.5	<0.5
Dup.	06/01/07	100 ^{13, 15}	<50	<300	11	<0.5	<0.5	<0.5	<0.5

**TABLE 1. Groundwater Analytical Results Summary
Port of Oakland's Harbor Facilities Complex Site
555 - 651 Maritime Street, Oakland, California**

Monitoring Well	Date Sampled	Concentration (µg/L)							
		TPH-G	TPH-D	TPH-MO	Benzene	Toluene	Ethyl-benzene	Total Xylenes	MTBE
MW-4 (cont)	11/14/07	54 ¹⁵	<50	<300	2.1	<0.5	<0.5	<0.5	<0.5
Dup.	11/14/07	51 ¹⁵	<50	<300	2.1	<0.5	<0.5	<0.5	<0.5
	06/05/08	67 ¹⁵	<50	<300	14	<0.5	<0.5	<0.5	<0.5
Dup.	06/05/08	91 ¹⁵	<50	<300	15	<0.5	<0.5	<0.5	<0.5
	12/18/08	99 ²	520	<300	0.5	<0.5	<0.5	<0.5	<0.5
Dup.	12/18/08	88 ²	850	<300	0.7	<0.5	0.6	<0.5	<0.5
	03/04/09	60 ²	<50	<300	3.8	<0.5	<0.5	<0.5	<0.5
Dup.	03/04/09	<50	<50	<300	4.4	<0.5	<0.5	<0.5	<0.5
	04/01/09	<50	<50	<300	7.5	<0.5	<0.5	<0.5	<0.5
Dup.	04/01/09	<50	<50	<300	7.8	<0.5	<0.5	<0.5	<0.5
	06/19/09	69 ²	<50	<300	15	<0.5	<0.5	<0.5	<0.5
	12/08/09	<50	<50	<300	3.3	<0.5	<0.5	<0.5	<0.5
Dup.	12/08/09	<50	<50	<300	3.5	<0.5	<0.5	<0.5	<0.5
	06/16/10	<50	<50	<300	15	<0.5	<0.5	<0.5	<0.5
Dup.	06/16/10	<50	<50	<300	18	<0.5	<0.5	<0.5	<0.5
	12/14/10	<50	<50	<300	2.2	<0.5	<0.5	<0.5	<0.5
Dup.	12/14/10	<50	<50	<300	2.7	<0.5	<0.5	<0.5	<0.5
	06/21/11	160 ²	<56	<330	30	<0.5	<0.5	<0.5	<0.5
Dup.	06/21/11	84 ²	<53	<320	28	<0.5	<0.5	<0.5	<0.5
	09/27/11	130 ²	72	<300	13	<0.5	<0.5	<0.5	<0.5
Dup.	09/27/11	130 ²	57 ²⁴	<300 ²⁴	12	<0.5	<0.5	<0.5	<0.5
	06/19/12	120 ²	<51	<310	19	<0.5	<0.5	<0.5	<0.5
Dup.	06/19/12	120 ²	<52	<310	20	<0.5	<0.5	<0.5	<0.5
	12/04/12	76 ²	<53	<320	1.7	<0.5	<0.5	<0.5	<0.5
Dup.	12/04/12	60 ²	56 ²	<310	1.3	<0.5	<0.5	<0.5	<0.5
	06/19/13	150 ²	<56	<330	19	<0.5	<0.5	<0.5	<0.5
Dup.	06/19/13	150 ²	<50	<300	19	<0.5	<0.5	<0.5	<0.5
MW-5									
	09/11/95	90	<300	2,500	3.3	<0.3	<0.3	<0.4	NA
	04/04/96	<50	180	520	<0.5	<0.5	<0.5	<1.0	NA
	07/10/96	<50	120	1,500	<0.4	<0.3	<0.3	<0.4	NA
	12/03/96	<50	200 ^{1,2}	<250	<0.5	<0.5	<0.5	<1.0	NA
	03/28/97	<50	<50	<250	<0.5	<0.5	<0.5	<1.0	NA
	06/13/97	<50	<50	<250	<0.5	<0.5	<0.5	<1.0	NA
	09/18/97	<50	<50	<250	<0.5	<0.5	<0.5	<1.0	NA
	12/31/97	<50	<47	<280	<0.5	<0.5	<0.5	<1.0	NA
	04/13/98	<50	<47	<280	<0.5	<0.5	<0.5	<1.0	NA
	11/06/98	<50	<50	<300	<0.5	<0.5	<0.5	<0.5	<2.0
	03/19/99	<50	<50	<300	<0.5	<0.5	<0.5	<0.5	<2.0
	06/24/99	<50	<50	<300	<0.5	<0.5	<0.5	<0.5	3.1
	09/28/99	<50	<50	<300	<0.5	<0.5	<0.5	<0.5	<2.0
	11/12/99	<50	110 ^{2,6}	<300	<0.5	<0.5	<0.5	<0.5	5.5 ⁹
	02/11/00	<50	<50	<300	<0.5	<0.5	<0.5	<0.5	<2.0
	05/22/00	<50	<50	<300	<0.5	<0.5	<0.5	<0.5	<2.0

**TABLE 1. Groundwater Analytical Results Summary
Port of Oakland's Harbor Facilities Complex Site
555 - 651 Maritime Street, Oakland, California**

Monitoring Well	Date Sampled	Concentration (µg/L)							
		TPH-G	TPH-D	TPH-MO	Benzene	Toluene	Ethyl-benzene	Total Xylenes	MTBE
MW-5 (cont)	09/06/00	<50	<50	<300	<0.5	<0.5	<0.5	<0.5	<2.0
	12/19/00	<50	<50	<300	<0.5	<0.5	<0.5	<0.5	<2.0
	02/21/01	<50	<50	<300	<0.5	<0.5	<0.5	<0.5	<2.0
	07/10/01	<50	<50	<300	<0.5	<0.5	<0.5	<0.5	<2.0
	12/05/01	<50	<50	<300	<0.5	<0.5	<0.5	<0.5	<2.0
	03/08/02	<50	<50	<500	<0.5	<0.5	<0.5	<0.5	<5.0
	06/13/02	<50	<50	<500	<0.5	<0.5	<0.5	<0.5	<5.0
	09/26/02	<50	<50	<500	<0.5	<0.5	<0.5	<0.5	<5.0
	12/12/02	<50	<50	<300	<0.5	<0.5	<0.5	<0.5	<2.0
	03/17/03	<50	<50	<300	<0.5	<0.5	<0.5	<0.5	<0.5 ¹⁰
	06/18/03	<50	<50	<300	<0.5	<0.5	<0.5	<0.5	<2.0
	09/03/03	<50	<50	<300	<0.5	<0.5	<0.5	<0.5	<2.0
	11/26/03	<50	<50	<300	<0.5	<0.5	<0.5	<0.5	4.1 ¹⁴ , <0.5 ¹⁰
	03/05/04	<50	<50	<300	<0.5	<0.5	<0.5	<0.5	<2.0
	06/02/04	<50	<50	<300	<0.5	<0.5	<0.5	<0.5	<2.0
	09/03/04	<50	<50	<300	<0.5	<0.5	<0.5	<0.5	<2.0
	12/16/04	<50	<50	<300	<0.5	<0.5	<0.5	<0.5	2.2 ¹⁴ , <0.5 ¹⁰
	03/29/05	<50	<50	<300	<0.5	<0.5	<0.5	<0.5	<2.0
	08/10/05	<50	<50	<250	<0.5	<0.5	<0.5	<0.5	<0.5
Dup.	08/10/05	<50 ¹⁹	<50 ¹⁹	<250	<0.5	<0.5	<0.5	<0.5	<0.5
	09/29/05	<50	<50	<250	<0.5	<0.5	<0.5	<0.5	<0.5
	12/21/05	<50	180 ^{15,22}	<300	<0.5	<0.5	<0.5	<0.5	<0.5
	07/28/06	<50	180	<300	<0.5	<0.5	<0.5	<0.5	<0.5
	11/29/06	<50	<50	<300	<0.5	<0.5	<0.5	<0.5	<0.5
	06/01/07	<50	<50	<300	<0.5	<0.5	<0.5	<0.5	<0.5
	11/14/07	<50	<50	<300	<0.5	<0.5	<0.5	<0.5	<0.5
	06/05/08	<50	<50	<300	<0.5	<0.5	<0.5	<0.5	<0.5
	12/18/08	3,100 ²	3,600	<300	0.5	<0.5	<0.5	<0.5	1.8
	03/04/09	<50	<50	<300	<0.5	<0.5	<0.5	<0.5	<0.5
	04/01/09	<50	<50	<300	<0.5	<0.5	<0.5	<0.5	<0.5
	04/01/09	<50	<50	<300	<0.5	<0.5	<0.5	<0.5	<0.5
	06/19/09	<50	<50	<300	<0.5	<0.5	<0.5	<0.5	<0.5
	12/08/09	<50	<50	<300	<0.5	<0.5	<0.5	<0.5	<0.5
	06/16/10	<50	<50	<300	<0.5	<0.5	<0.5	<0.5	<0.5
	12/14/10	<50	<50	<300	<0.5	<0.5	<0.5	<0.5	<0.5
	06/22/11	<50	<50	<300	<0.5	<0.5	<0.5	<0.5	<0.5
	09/27/11	<50	<50 ²⁴	<300 ²⁴	<0.5	<0.5	<0.5	<0.5	<0.5
	06/19/12	<50	<51	<310	<0.5	<0.5	<0.5	<0.5	<0.5
	12/04/12	<50	<54	<330	<0.5	<0.5	<0.5	<0.5	<0.5
	06/19/13	<50	<53	<320	<0.5	<0.5	<0.5	<0.5	<0.5

**TABLE 1. Groundwater Analytical Results Summary
Port of Oakland's Harbor Facilities Complex Site
555 - 651 Maritime Street, Oakland, California**

Monitoring Well	Date Sampled	Concentration (µg/L)							
		TPH-G	TPH-D	TPH-MO	Benzene	Toluene	Ethyl-benzene	Total Xylenes	MTBE
MW-6									
	11/06/98	120	12,000	1,200	19	0.65	1.8	<0.5	<2
	03/19/99	170	3,800	580	21	0.86	1.5	2.9	<2
	06/24/99	120	1,700 ⁷	<300 ⁷	18	<0.5	1.0	<0.5	54
	09/28/99	130 ^{3,5}	820	<300	20	0.51	2.2	<0.5	<2
	11/12/99	150	11,000 ^{2,6}	3,000 ^{3,6}	27	<0.5	2.2	<0.5	13 ⁹
	02/11/00	270 ²	2,300	<300	23	0.51	2.7	<0.5	5.8
	05/22/00	350	3,000	<300	18	0.51	<0.5	<0.5	7.7
	09/06/00	190	610	<300	26	<0.5	1.7	<0.5	<0.5 ¹⁰
	12/19/00	130 ^{3,11}	620	<300	24	<0.5	1.6	<0.5	<2
	02/21/01	120 ¹³	440	<300	21	<0.5	0.96	<0.5	<2
	07/10/01	120	560	<300	29	<0.5	0.99	<0.5	<2
	12/12/01	53	550	<300	27	<0.5	1.3	<0.5	<2.0
	03/08/02	160 ²	640 ²	<500	30	<0.5	<0.5	<0.5	5.0 ¹⁴
	06/13/02	160 ²	670 ²	<500	34	<0.5	<0.5	<0.5	<5.0
	09/26/02	230 ²	1400 ²	<500	40	0.64	0.8	<0.5	<5.0
	12/12/02	53	110	<300	43	<0.5	<0.5	<0.5	<2.0
	12/18/02	Monitoring well was destroyed							
MW-7									
	09/06/95	<50	<300	800	<0.4	<0.3	<0.3	<0.4	NA
	01/08/96	<50	410	110	<0.4	<0.3	<0.3	<0.4	NA
	04/04/96	<50	530	340	<0.5	<0.5	<0.5	<1.0	NA
	07/10/96	80	840	1,700	<0.4	<0.3	<0.3	<0.4	NA
	12/03/96	<50	280 ^{1,2}	<250	<0.5	<0.5	<0.5	<1.0	NA
	03/28/97	65 ⁶	94 ²	<250	<0.5	<0.5	<0.5	<1.0	NA
	06/13/97	<50	100	<250	<0.5	<0.5	<0.5	<1.0	NA
	09/18/97	<50	240	<250	<0.5	<0.5	<0.5	<1.0	NA
	12/31/97	<50	53 ^{2,3}	<280	<0.5	<0.5	<0.5	<1.0	NA
	04/13/98	<50	<48	<290	<0.5	<0.5	<0.5	<1.0	NA
	11/06/98	<50	<50	<300	<0.5	<0.5	<0.5	<0.5	<2
	03/19/99	<50	<50	<300	<0.5	<0.5	<0.5	<0.5	5.3
	06/24/99	73	<50	<300	<0.5	<0.5	<0.5	<0.5	12
	09/28/99	<50	<50	<300	<0.5	<0.5	<0.5	<0.5	14
	11/12/99	<50	600 ^{2,6}	420 ³	<0.5	<0.5	<0.5	<0.5	15 ⁹
	02/11/00	<50	<50	<300	<0.5	<0.5	<0.5	<0.5	51
	05/22/00	110	53 ²	<300	<0.5	<0.5	<0.5	<0.5	75
	09/06/00	50 ⁶	<50	<300	<0.5	<0.5	<0.5	<0.5	40 ¹⁰
	12/19/00	54 ¹¹	51 ⁵	<300	<0.5	<0.5	<0.5	<0.5	47 ^{10,12}
	02/21/01	<50	<50	<300	<0.5	<0.5	<0.5	<0.5	66 ¹⁰
Dup.	02/21/01	<50	<50	<300	<0.5	<0.5	<0.5	<0.5	60 ¹⁰
	07/10/01	<50	51 ²	<300	<0.5	<0.5	<0.5	<0.5	76 ¹⁰
Dup.	07/10/01	<50	<50	<300	<0.5	<0.5	<0.5	<0.5	75 ¹⁰

**TABLE 1. Groundwater Analytical Results Summary
Port of Oakland's Harbor Facilities Complex Site
555 - 651 Maritime Street, Oakland, California**

Monitoring Well	Date Sampled	Concentration (µg/L)							
		TPH-G	TPH-D	TPH-MO	Benzene	Toluene	Ethyl-benzene	Total Xylenes	MTBE
MW-7 (cont)	12/12/01	51	<50	<300	<0.5	<0.5	<0.5	<0.5	98 ¹⁴
Dup.	12/12/01	64	52 ^{13,15}	<300	<0.5	<0.5	<0.5	<0.5	96 ¹⁴
	03/08/02	52 ²	<50	<500	<0.5	<0.5	<0.5	<0.5	24 ¹⁴
	06/13/02	87 ²	54 ²	<500	<0.5	<0.5	<0.5	<0.5	51
	09/26/02	83 ²	84 ²	<500	<0.5	<0.5	<0.5	<0.5	75 ¹⁰
	12/12/02	<50	<50	<300	<0.5	<0.5	<0.5	<0.5	58 ¹⁴
	12/18/02	Monitoring well was destroyed							
MW-8									
	Not sampled due to the presence of free-phase product								
MW-8A									
	12/12/01	68	720 ^{11,15}	<300	<0.5	<0.5	<0.5	<0.5	<2.0
	03/08/02	<50	760 ²	<570	<0.5	<0.5	<0.5	<0.5	<5.0
Dup.	03/08/02	<50	350 ²	<580	<0.5	<0.5	<0.5	<0.5	<5.0
	06/13/02	<50	570 ²	<570	<0.5	<0.5	<0.5	<0.5	<5.0
	09/26/02	<50	410 ²	<500	<0.5	<0.5	<0.5	<0.5	<5.0
	12/12/02	<50	160 ¹⁵	<300	<0.5	<0.5	<0.5	<0.5	<2.0
	03/17/03	<50	<50	<300	<0.5	<0.5	<0.5	<0.5	<0.5 ¹⁰
	06/18/03	<50	74 ¹⁵	<300	<0.5	<0.5	<0.5	<0.5	<2.0
	09/03/03	<50	<50	<300	<0.5	<0.5	<0.5	<0.5	3.0 ¹⁴ / <0.5 ¹⁰
	11/26/03	<50	94 ¹⁵	<300	<0.5	<0.5	<0.5	<0.5	<2.0
	03/05/04	<50	<50	<300	<0.5	<0.5	<0.5	<0.5	<2.0
	06/02/04	<50	67 ¹⁵	<300	<0.5	<0.5	<0.5	<0.5	<2.0
	09/03/04	<50	86 ¹⁵	<300	<0.5	<0.5	<0.5	<0.5	<2.0
	12/16/04	<50	160 ^{6,15}	<300	<0.5	<0.5	<0.5	<0.5	<2.0
	03/29/05	<50	53	<300	<0.5	<0.5	<0.5	<0.5	<2.0
	08/10/05	<50 ¹⁹	150 ^{15,19}	<250	<0.5	<0.5	<0.5	<0.5	<0.5
	09/29/05	<50	66 ²¹	<250	<0.5	<0.5	<0.5	<0.5	<0.5
	12/21/05	<50	63 ^{15,22}	<300	<0.5	<0.5	<0.5	<0.5	<0.5
	03/24/06	<50	71	<300	<0.5	<0.5	<0.5	<0.5	<0.5
	07/28/06	<50	70 ¹⁵	<300	<0.5	<0.5	<0.5	<0.5	<0.5
	11/29/06	<50	<50	<300	<0.5	<0.5	<0.5	<0.5	<0.5
	06/01/07	<50	<50	<300	<0.5	<0.5	<0.5	<0.5	<0.5
	11/14/07	<50	<50	<300	<0.5	<0.5	<0.5	<0.5	<0.5
	06/05/08	<50	<50	<300	<0.5	<0.5	<0.5	<0.5	<0.5
	12/18/08	350 ²	7,800	2,200 ²	<0.5	<0.5	<0.5	<0.5	1.3
	03/04/09	<50	51 ²	<300	<0.5	<0.5	<0.5	<0.5	<0.5
	04/01/09	<50	<50	<300	<0.5	<0.5	<0.5	<0.5	<0.5
	06/17/09	<50	<50	<300	<0.5	<0.5	<0.5	<0.5	<0.5
	12/08/09	<50	<50	<300	<0.5	<0.5	<0.5	<0.5	<0.5
	06/16/10	<50	<50	<300	<0.5	<0.5	<0.5	<0.5	<0.5

**TABLE 1. Groundwater Analytical Results Summary
Port of Oakland's Harbor Facilities Complex Site
555 - 651 Maritime Street, Oakland, California**

Monitoring Well	Date Sampled	Concentration (µg/L)							
		TPH-G	TPH-D	TPH-MO	Benzene	Toluene	Ethyl-benzene	Total Xylenes	MTBE
MW-8A (cont)	12/14/10	<50	<50	<300	<0.5	<0.5	<0.5	<0.5	<0.5
	06/23/11	<50	<50	<300	<0.5	<0.5	<0.5	<0.5	<0.5
	09/26/11	<50	<50 ²⁴	<300 ²⁴	<0.5	<0.5	<0.5	<0.5	<0.5
	06/19/12	<50	<51	<310	<0.5	<0.5	<0.5	<0.5	<0.5
	12/04/12	<50	<53	<320	<0.5	<0.5	<0.5	<0.5	<0.5
	06/19/13	<50	<52	<310	<0.5	<0.5	<0.5	<0.5	<0.5
MW-9									
	12/18/08	52 ²	72	<300	<0.5	<0.5	<0.5	<0.5	<0.5
	03/04/09	290 ²	310 ²	<300	44	<0.5	0.6	0.6	<0.5
	04/01/09	210 ²	210 ²	<300	36	<0.5	<0.5	<0.5	<0.5
	06/19/09	240 ²	240 ²	<300	43	<0.5	<0.5	<0.5	<0.5
	12/08/09	210 ²	210 ²	<300	48	<0.5	<0.5	<0.5	<0.5
	06/16/10	160 ²	160 ²	<300	49	<0.5	1.0	0.6	<0.5
	12/14/10	170 ²	130 ²	<300	34	<0.5	<0.5	0.6	<0.5
	06/22/11	200 ²	160 ²	<300	25	<0.5	<0.5	<0.5	<0.5
	09/27/11	190 ²	180 ²⁴	<300 ²⁴	21	<0.5	<0.5	<0.5	<0.5
	06/19/12	150 ²	96 ²	<320	11	<0.5	<0.5	<0.5	<0.5
	12/04/12	140 ²	200 ²	<320	14	<0.5	1.8	1.5	<0.5
	06/19/13	130	100 ²	<320	14	<0.5	1.1	<0.5	<0.5
MW-10									
	12/18/08	140 ²	8,000	430 ²	<0.5	<0.5	<0.5	<0.5	1.0
	03/04/09	96 ²	110 ²	<300	11	<0.5	0.5	<0.5	<0.5
	04/01/09	87 ²	100 ²	<300	14	<0.5	0.5	<0.5	<0.5
	06/17/09	90 ²	220 ²	<300	10	<0.5	1.0	<0.5	<0.5
	12/08/09	120 ²	240 ²	<300	26	<0.5	0.8	<0.5	<0.5
	06/16/10	140 ²	200	<300	46	<0.5	<0.5	<0.5	<0.5
	12/14/10	150 ²	140 ²	<300	47	<0.5	<0.5	<0.5	<0.5
	06/22/11	320 ²	630	<300	54	<0.5	2.2	<0.5	<0.5
	09/26/11	260 ²	780 ²⁴	<300 ²⁴	61	1	2.4	<0.5	<0.5
	06/19/12	330 ²	430 ²	<310	58	<0.5	2.9	<0.5	<0.5
	12/04/12	250 ²	1,100	<320	59	<0.5	0.9	<0.5	<0.5
	06/19/13	320 ²	280 ²	<310	61	<0.5	1.2	<0.5	<0.5
MW-11									
	12/18/08	1,900 ²	15,000	800 ²	<0.5	<0.5	<0.5	<0.5	5.0
	03/04/09	<50	<50	<300	<0.5	<0.5	<0.5	<0.5	<0.5
	04/01/09	<50	<50	<300	<0.5	<0.5	<0.5	<0.5	<0.5
	06/19/09	<50	<50	<300	<0.5	<0.5	<0.5	<0.5	<0.5
	12/09/09	<50	<50	<300	<0.5	<0.5	<0.5	<0.5	<0.5
	06/16/10	<50	<50	<300	<0.5	<0.5	<0.5	<0.5	<0.5
	12/14/10	<50	<50	<300	<0.5	<0.5	<0.5	<0.5	<0.5
	06/21/11	<50	<50	<300	<0.5	<0.5	<0.5	<0.5	<0.5
	09/26/11	<50	<50 ²⁴	<300 ²⁴	<0.5	<0.5	<0.5	<0.5	<0.5
	06/19/12	<50	<53	<320	<0.5	<0.5	<0.5	<0.5	<0.5
	12/04/12	<50	<53	<320	<0.5	<0.5	<0.5	<0.5	<0.5
	06/19/13	<50	<50	<300	<1.0	<1.0	<1.0	<1.0	<1.0

**TABLE 1. Groundwater Analytical Results Summary
Port of Oakland's Harbor Facilities Complex Site
555 - 651 Maritime Street, Oakland, California**

Monitoring Well	Date Sampled	Concentration (µg/L)							
		TPH-G	TPH-D	TPH-MO	Benzene	Toluene	Ethyl-benzene	Total Xylenes	MTBE
MW-12									
	12/18/08	25,000 ²	19,000	980 ²	<0.5	<0.5	<0.5	<0.5	5.1
	03/04/09	150 ²	550 ²	<300	<0.5	<0.5	<0.5	<0.5	4.8
	04/01/09	71 ²	420 ²	<300	<0.5	<0.5	<0.5	<0.5	5.8
	06/17/09	64 ²	310 ²	<300	<0.5	<0.5	<0.5	<0.5	5.7
Dup.	06/17/09	67 ²	310 ²	<300	<0.5	<0.5	<0.5	<0.5	5.4
	12/08/09	90 ²	320 ²	<300	<0.5	<0.5	<0.5	<0.5	4.7
	06/16/10	94 ²	300	<300	<0.5	<0.5	<0.5	<0.5	4.8
	12/14/10	100 ²	510	<300	<0.5	<0.5	<0.5	<0.5	4.0
	06/23/11	100 ²	270 ²	<300	<0.5	<0.5	<0.5	<0.5	3.2
	09/26/11	62 ²	500 ²⁴	<300 ²⁴	<0.5	<0.5	<0.5	<0.5	4.2
	06/19/12	88	370 ²	<310	<0.5	<0.5	<0.5	<0.5	2.4
	12/04/12	95 ²	390 ²	<320	<0.5	<0.5	<0.5	<0.5	3.9
	06/19/13	66 ²	220 ²	<300	<0.5	<0.5	<0.5	<0.5	4.5

Notes:

Data prior to December 2005 from *3rd Quarterly Groundwater Monitoring, and Product Recovery Report* dated 8 November 2005, by Innovative Technical Solutions, Inc.

µg/L = micrograms per liter

Dup. = duplicate sample

NA = not analyzed

TPHg = total petroleum hydrocarbons in gasoline range.

TPHd = total petroleum hydrocarbons in diesel range.

TPHmo = total petroleum hydrocarbons in motor oil range.

MTBE = methyl tert-butyl ether

¹ Analyte found in the associated blank as well as in the sample.

² Hydrocarbons present do not match profile of laboratory standard.

³ Low boiling point/lighter hydrocarbons are present in the sample.

⁴ Chromatographic pattern matches known laboratory contaminant.

⁵ Hydrocarbons are present in the requested fuel quantification range, but do not resemble pattern of available fuel standard.

⁶ High boiling point/heavier hydrocarbons are present in sample.

⁷ Sample did not pass laboratory QA/QC and may be biased low.

⁸ Presence of this compound confirmed by second column, however, the confirmation concentration differed from the reported result by more than a factor of two.

⁹ Trip blank contained MTBE at a concentration of 4.2 µg/L.

¹⁰ MTBE detections confirmed by EPA Test Method 8260; 8260 results displayed.

¹¹ Sample exhibits unknown single peak or peaks.

¹² EPA Method 8260 confirmation analyzed past holding time.

¹³ Lighter hydrocarbons contributed to the quantitation.

¹⁴ MTBE results from EPA Test Method 8021B.

¹⁵ Sample exhibits fuel pattern that does not resemble standard.

¹⁶ Sample extracted out of hold time.

¹⁷ Presence confirmed, but Relative Percent Difference (RPD) between columns exceeds 40%.

¹⁸ Unmodified or weakly modified gasoline is significant.

¹⁹ Liquid sample contains greater than ~1 vol. % sediment.

²⁰ Gasoline compounds are significant.

**TABLE 1. Groundwater Analytical Results Summary
Port of Oakland's Harbor Facilities Complex Site
555 - 651 Maritime Street, Oakland, California**

Monitoring Well	Date Sampled	Concentration (µg/L)							
		TPH-G	TPH-D	TPH-MO	Benzene	Toluene	Ethyl-benzene	Total Xylenes	MTBE

²¹ Diesel range compounds are significant; no recognizable pattern.

²² Heavier hydrocarbons contributed to the quantitation.

²³ Analyzed outside of holdtime after confirmation of laboratory contamination by (2-ethylhexyl)phthalate.

²⁴ Analyzed both pre- and post-silica gel cleanup. Post-silica gel cleanup results are reported herein. Pre-silica gel cleanup results are included in Appendix B.

**TABLE 2. Groundwater Analytical Results Summary
Monitored Natural Attenuation Parameters
Port of Oakland's Harbor Facilities Complex Site
555 - 651 Maritime Street, Oakland, California**

Monitoring Well	Date Sampled	Field Parameters				Analytical Concentrations																	Total Dissolved Solids (mg/L)
		DO (mg/L)	ORP (mV)	Iron (II) (mg/L)	Carbon Dioxide (mg/L)	Methane (µg/L)	Iron (II) (mg/L)	Manganese (II) (mg/L)	Calcium (mg/L)	Magnesium (mg/L)	Potassium (mg/L)	Sodium (mg/L)	Sulfide (Dissolved, mg/L)	Nitrate (as N, mg/L)	Nitrite (as N, mg/L)	Sulfate (mg/L)	Chloride (mg/L)	Orthophosphate (as P, mg/L)	Carbonate (mg/L)	Bicarbonate (mg/L)	Alkalinity, Total (as CaCO ₃ , mg/L)		
MW-1	06/22/11	0.04	-99.7	0.91	17	6,300	0.84	0.52	25	16	1.0	48	0.24	<0.05	<0.05	<0.50	11	0.13	<6.7	250	250	270	
	09/26/11																						
		Not sampled due to the presence of free-phase product																					
MW-2	06/22/11	3.27	27.3	0.00	23	0.69	<0.10	0.077	26	27	1.1	150	<0.04	0.25	<0.05	31	19	0.13	<6.7	500	500	610	
	09/26/11	0.38	108.5	0.00	31	18	<0.10	0.19	29	29	1.3	180	<0.04	<0.05	<0.05	29	23	0.15	<10	560	560	660	
MW-3	6/22/2011																						
	9/26/2011																						
		Not sampled due to the presence of free-phase product																					
MW-4	06/21/11	0.09	-32.0	0.05	2.5 J	3,400	<0.10	0.18	21	57	14	340	<0.04	<0.05	<0.05	5.3	280	0.64	<6.7	800	800	1,280	
Dup.	06/21/11	0.09	-32.0	0.04	3.1	3,500	<0.10	0.18	20	58	14	340	<0.04	<0.05	<0.05	5.5	280	0.64	<6.7	770	770	1,270	
	09/27/11	0.42	-137.0	0.51	15	4,100	0.46	0.31	41	68	9.8	250	<0.04	<0.05	<0.05	1.9	170	0.53	<10	860	860	1,150 ¹	
Dup.	09/27/11	0.42	-137.0	0.51	16	4,100	0.27	0.25	36	65	9.2	240	<0.04	<0.05	<0.05	2.0	150	0.51	<10	810	810	1,150 ¹	
MW-5	06/22/11	0.24	-52.5	0.30	27	74	0.46	0.67	48	21	16	230	<0.04	<0.05	<0.05	69	300	0.35	<6.7	360	360	960	
	09/27/11	0.33	-68.5	0.59	30	78	0.59	0.77	54	22	17	260	<0.04	<0.05	<0.05	74	290	0.33	<10	350	350	1,010 ¹	
MW-6	12/18/02																						
		Monitoring well was destroyed																					
MW-7	12/18/02																						
		Monitoring well was destroyed																					
MW-8	11/21/98																						
		Monitoring well was destroyed and replaced with well MW-8A																					
MW-8A	06/23/11	0.44	-203.1	1.85	5.0	400	2.3	0.67	46	58	15	230	<0.04	<0.05	<0.05	38	140	1.3	<6.7	760	760	1,060	
	09/26/11	0.16	-109.1	2.57	52	310	2.9	0.85	53	65	18	280	<0.04	<0.05	<0.05	47	160	1.3	<10	810	810	360	
MW-9	06/22/11	0.14	-130.1	3.30*	71	10,000	6.3	0.87	70	46	14	280	0.09	<0.05	<0.05	0.54	290	1.3	<6.7	750	750	1,240	
	09/27/11	0.22	-122.2	3.62	71	9,500	6.6	0.93	71	46	15	350	0.08	<0.05	<0.05	0.69	270	1.3	<10	770	770	1,360 ¹	
MW-10	06/22/11	0.03	-118	3.30*	160	7,300	7.8	4.2	130	67	30	420	0.09	<0.05	<0.10	4.1	530	0.46	<6.7	1,100	1,100	2,030	
	09/26/11	0.15	-138.7	2.1	170	7,300	8.8	4.5	150	72	31	450	0.11	<0.05	<0.05	28	520	0.60	<10	1,100	1,100	680	
MW-11	06/21/11	0.06	-178.4	0.93	44	7,900	1.4	0.39	25	52	46	970	<0.04	<0.10	<0.10	<1.0	970	9.6	<6.7	1,500	1,500	3,140	
	09/26/11	0.20	-198.9	0.47	46	8,300	1.5	0.38	25	51	49	1,100	<0.04	<0.05	<0.05	<1.0	1,000	7.7	<10	1,500	1,500	3,180	
MW-12	06/23/11	0.18	-253.8	0.41	85	5,100	0.46	1.3	93	43	15	160	4.7	<0.05	<0.05	2.4	180	0.76	<6.7	620	620	940	
	09/26/11	0.36	-260.9	0.40	88	4,900	0.67	1.4	96	43	15	180	3.3	<0.05	<0.05	1.5	180	0.73	<10	640	640	1,000	

Notes:
 * Sample iron (II) concentration exceeded range of instrument.
 DO = dissolved oxygen
 ORP = oxidation-reduction potential
 mg/L = milligrams per liter
 µg/L = microgram per liter
 N = nitrogen
 P = phosphorus
 CaCO₃ = calcium carbonate
 J = estimated value
¹ Batch spike duplicate for TDS outside of acceptable relative percent difference range.

**Table 5. Groundwater Sample Results, 2225 7th Street
Port of Oakland
2277 and 2225 7th Street, Oakland California**

Monitoring Well ID	Date	TPHg (µg/l)	TPHd (µg/l)	TPHmo (µg/l)	Benzene (µg/l)	Toluene (µg/l)	Ethylbenzene (µg/l)	Total Xylenes (µg/l)	MTBE (µg/l)
MW-1	1/15/93	<50	<50	NA	<0.3	<0.3	<0.3	<0.3	NA
	9/12/94	<10 ¹	10,000	NA	0.5	<0.3	<0.3	<0.3	NA
	11/30/94	<10	2,800	NA	<0.3	<0.3	<0.3	<0.3	NA
	3/29/95	<50	<50	NA	<0.3	<0.3	<0.3	<0.3	NA
	6/21/95	<50	<50 ²	NA	<0.3	<0.3	<0.3	<0.3	NA
	9/28/95	<50	<50	NA	<0.3	<0.3	<0.3	<0.3	NA
	12/27/95	<50	<50	<100	<0.3	<0.3	<0.3	<0.3	NA
	3/25/96	<50	<50	<100	<0.3	<0.3	<0.3	<0.3	NA
	6/26/96	<50	<50	NA	<0.5	<0.5	<0.5	<0.5	<5.0
	10/14/96	<50	<50	NA	<0.5	<0.5	<0.5	<0.5	<5.0
	3/19/97	<50	<50	NA	<0.5	<0.5	<0.5	<0.5	<5.0
	6/26/00	<50	<50	<300	<0.5	<0.5	<0.5	<0.5	<0.5 ³
	12/19/00	<50	<50	<300	<0.5	<0.5	<0.5	<0.5	<2
	12/19/00	<50	<50	<300	<0.5	<0.5	<0.5	<0.5	<2
7/10/01	<50	<50	<300	<0.5	<0.5	<0.5	<0.5	<2	
7/10/01	<50	<50	310	<0.5	<0.5	<0.5	<0.5	<2	
12/12/01	<50	<50	<300	<0.5	<0.5	<0.5	<0.5	<2	
MW-2	1/15/93	<50	<50	NA	<0.3	<0.3	<0.3	<0.3	NA
	9/12/94	34 ¹	<50	NA	0.5	<0.3	<0.3	<0.3	NA
	11/30/94	<10	81	NA	0.9	<0.3	<0.3	<0.3	NA
	3/29/95	<50 ³	75	NA	0.3	<0.3	<0.3	<0.3	NA
	6/21/95	<50 ³	<50	NA	<0.3	<0.3	<0.3	<0.3	NA
	9/28/95	250 ¹	<50	NA	<0.3	<0.3	<0.3	<0.3	NA
	12/27/95	220 ¹	<50	<100	<0.3	<0.3	<0.3	<0.3	NA
	3/25/96	200 ¹	<50	<100	<0.3	<0.3	<0.3	<0.3	NA
	6/26/96	77 ⁴	<50	NA	<0.5	<0.5	<0.5	<0.5	<5.0
	10/14/96	<50	<50	NA	<0.5	<0.5	<0.5	<0.5	<5.0
	3/19/97	150	<50	NA	<0.5	<0.5	<0.5	<0.5	<5.0
	6/26/00	<50	<50	<300	<0.5	<0.5	<0.5	<0.5	<0.5 ⁵
	12/19/00	<50	<50	<300	<0.5	<0.5	<0.5	<0.5	<2
	7/10/01	<50	<50	<300	<0.5	<0.5	<0.5	<0.5	<2
12/12/01	<50	<50	<300	<0.5	<0.5	<0.5	<0.5	<2	
MW-3	1/15/93	<50	<50	NA	<0.3	<0.3	<0.3	<0.3	NA
	9/12/94	<50	<50	NA	0.3	<0.3	<0.3	<0.3	NA
	11/30/94	110	150	NA	<0.3	<0.3	<0.3	<0.3	NA
	3/29/95	<50	<50	NA	<0.3	<0.3	<0.3	<0.3	NA
	6/21/95	<50 ³	<50 ²	NA	<0.3	<0.3	<0.3	<0.3	NA
	9/28/95	51 ¹	<50	NA	<0.3	<0.3	<0.3	<0.3	NA
	12/27/95	55 ¹	<50	<100	<0.3	<0.3	<0.3	<0.3	NA
	3/25/96	53	<50	<100	<0.3	<0.3	<0.3	<0.3	NA
	6/26/96	<50	<50	NA	<0.5	<0.5	<0.5	<0.5	<5.0
	10/14/96	<50	<50	NA	<0.5	<0.5	<0.5	<0.5	<5.0
	3/19/97	<50	<50	NA	<0.5	<0.5	<0.5	<0.5	<5.0
	6/26/00	<50	<50	<300	<0.5	<0.5	<0.5	<0.5	<0.5 ⁵
	12/19/00	<50	50 ²	<300	<0.5	<0.5	<0.5	<0.5	<2
	7/10/01	<50	<50	<300	<0.5	<0.5	<0.5	<0.5	<2
12/12/01	<50	<50	<300	<0.5	<0.5	<0.5	<0.5	<2	

NA Not Analyzed.

¹ Hydrocarbon pattern is not characteristic of gasoline

² Hydrocarbon pattern present in sample is not characteristic of diesel

³ Uncategorized compound not included in the gasoline concentration

⁴ Product is not typical gasoline

⁵ MTBE detected by EPA Test Method 8021B but reported as ND<0.5 by EPA Test Method 8260

⁶ Heavier hydrocarbons contributed to the quantitation

- Data prior to June 26, 2000 taken from *First Quarter 1997 Groundwater Monitoring and Sampling report* dated May 6, 1999, by Fluor Daniel GTI.

Attachment 8

All available free product thickness data

**MONITORING AND RECOVERY WELL PRODUCT THICKNESS MEASUREMENTS
PORT OF OAKLAND
HARBOR FACILITY CENTER
2225 7TH STREET
OAKLAND, CALIFORNIA**

Well ID	Installed Well Total Depth (feet)	Total Depth Measured 10/5 & 6/04 (feet)	4/29/2004			5/11/2004			5/18/2004			10/5/2004 - 10/6/2004		
			DTP	DTW	PT	DTP	DTW	PT	DTP	DTW	PT	DTP	DTW	PT
RW-1	18.0	15.02	ND	8.20	ND	ND	6.60	ND	ND	6.90	ND	ND	8.45	ND
RW-2	21.0	--	ND	10.01	ND	ND	9.10	ND	ND	9.19	ND	--	--	ND
RW-3	21.0	15.45	ND	10.10	ND	ND	8.90	ND	ND	9.11	ND	10.81	10.84	0.03
RW-4	21.0	15.85	8.55	8.60	0.05	7.70	7.75	0.05	8.02	8.12	0.10	10.06	10.11	0.05
RW-5	21.0	14.42	ND	8.71	ND	ND	7.10	ND	ND	7.32	ND	ND	8.04	ND
RW-6	21.0	17.02	ND	8.80	ND	ND	7.35	ND	7.45	7.48	0.03	8.79	8.82	0.03
RW-7	21.0	15.60	ND	8.55	ND	ND	7.20	ND	7.35	7.37	0.02	8.41	8.67	0.26
RW-8	22.0	15.91	ND	8.66	ND	ND	7.65	ND	ND	7.70	ND	9.09	9.17	0.08
RW-9	22.0	17.02	ND	10.95	ND	ND	9.40	ND	9.65	9.67	0.02	10.24	10.26	0.02
MW-1	--	14.97	--	--	ND	--	--	ND	8.30	8.75	0.45	8.85	9.36	0.51
MW-2	--	--	--	--	ND	--	--	ND	ND	11.26	ND	--	--	ND
MW-3	--	17.10	--	--	ND	--	--	ND	10.02	11.34	1.32	10.65	12.68	2.03

Notes:

DTP = depth to product in feet below top of well casing

DTW = depth to water in feet below top of well casing

PT = product thickness in measured in feet

-- = not measured

ND = not detected

RW = new recovery well

MW = existing monitoring well

3.2 Measurement Data

The following tables show the data collected from the system over the first year of operation.

TABLE 1
1st Quarter 2005

	Recovery Well ID	12/14/04	12/23/04	1/3/05	1/13/05	1/27/05	2/10/05	3/23/05	3/25/05	3/29/05	3/30/05
Depth to Water	RW-3	11.17	11.10	9.15	8.86	10.85	10.66	8.75	8.64	8.19	8.26
	RW-4	9.24	9.45	7.80	7.87	8.05	8.41	8.05	NM	7.45	NM
	RW-6	9.36	9.47	8.70	8.48	8.36	8.47	7.98	NM	8.01	7.41
	RW-7	8.31	8.45	7.57	7.38	7.67	7.70	7.67	NM	7.39	NM
	RW-8	9.09	9.13	8.66	8.5	8.40	8.55	8.40	NM	8.16	NM
Depth to Product	RW-3	9.86	10.25	8.50	8.32	8.81	9.26	8.16	8.17	8.14	8.22
	RW-4	9.22	9.44	7.79	7.86	8.04	8.30	8.04	NM	7.30	NM
	RW-6	8.36	8.49	7.95	7.81	7.72	7.78	7.37	NM	7.40	7.39
	RW-7	8.11	8.21	7.33	7.38	7.39	7.51	7.39	NM	7.06	NM
	RW-8	9.05	9.10	8.63	8.48	8.38	8.54	8.38	NM	8.15	NM
Product Thickness	RW-3	1.31	0.85	0.65	0.54	2.04	1.40	0.59	0.47	0.05	0.04
	RW-4	0.02	0.01	0.01	0.01	0.01	0.11	0.01	NM	0.15	NM
	RW-6	1.00	0.98	0.75	0.67	0.64	0.69	0.61	NM	0.61	0.02
	RW-7	0.20	0.24	0.24	0.30	0.28	0.19	0.28	NM	0.33	NM
	RW-8	0.04	0.03	0.03	0.02	0.02	0.01	0.02	NM	0.01	NM

NM = Not Measured

Units are in feet.

System operation from initial startup in December of 2004 to the end of the first quarter of 2005.

TABLE 2
2nd Quarter 2005

	Recovery Well ID	4/5/05	4/8/05	4/22/05	5/6/05
Depth to Water	RW-3	8.65	8.61	9.50	9.88
	RW-4	7.73	7.23	7.96	8.15
	RW-6	7.61	7.63	7.91	7.92
	RW-7	7.39	7.33	7.35	7.42
	RW-8	8.02	8.03	8.08	8.23
Depth to Product	RW-3	8.38	8.32	8.78	8.99
	RW-4	7.60	7.11	7.94	8.10
	RW-6	7.42	7.41	7.58	7.66
	RW-7	7.02	6.98	7.16	7.28
	RW-8	8.01	8.02	8.07	8.22
Product Thickness	RW-3	0.27	0.29	0.72	0.89
	RW-4	0.13	0.12	0.02	0.05
	RW-6	0.19	0.22	0.33	0.26
	RW-7	0.37	0.35	0.19	0.14
	RW-8	0.01	0.01	0.01	0.01

Units are in feet.

System operation for the second quarter of 2005.

Note:

In general, the frequency of measurement of free product and water levels in the recovery wells is governed by weather patterns. During the dryer months (typically May – November) measurements can be taken on a monthly basis. Starting with the first rain (typically December) this should be stepped up to bi-weekly. In the case of extremely heavy rainfall during any given week, the measurement frequency may need to be increased to weekly intervals.

TABLE 3
3rd Quarter 2005

	Recovery Well ID	9/12/05	9/27/05
Depth to Water	RW-1	7.85	8.40
	RW-2	10.23	10.33
	RW-3	11.11	11.26
	RW-4	9.74	9.92
	RW-5	7.83	NM
	RW-6	8.79	8.93
	RW-7	8.04	8.15
	RW-8	9.26	9.32
	RW-9	10.27	10.73
Depth to Product	RW-1	ND	ND
	RW-2	ND	ND
	RW-3	10.11	10.26
	RW-4	1.00	9.58
	RW-5	ND	NM
	RW-6	8.26	8.34
	RW-7	7.85	7.92
	RW-8	8.62	8.68
	RW-9	ND	ND
Product Thickness	RW-1	ND	ND
	RW-2	ND	ND
	RW-3	1.00	1.00
	RW-4	0.39	0.34
	RW-5	ND	NM
	RW-6	0.53	0.59
	RW-7	0.19	0.23
	RW-8	0.64	0.64
	RW-9	ND	ND

NM = Not Measured

ND = Not Detected

Units are in feet.

System operation for the third quarter of 2005.

TABLE 4
4th Quarter 2005

	Recovery Well ID	10/5/05	10/21/05	11/2/05	11/16/05	12/2/05	12/14/05	12/28/05
Depth to Water	RW-1	7.96	8.10	8.12	8.72	8.63	NM	NM
	RW-2	10.42	10.52	10.50	10.66	10.01	9.79	8.11
	RW-3	10.85	10.87	10.82	12.08	12.13	11.89	9.83
	RW-4	9.83	9.76	9.99	10.11	9.36	9.82	8.65
	RW-5	NM	8.04	NM	NM	NM	7.96	6.81
	RW-6	8.74	8.65	8.81	8.71	8.73	8.49	7.44
	RW-7	8.14	8.17	8.21	8.30	8.37	8.14	7.22
	RW-8	9.31	9.33	9.42	9.41	9.33	9.02	7.89
	RW-9	10.73	10.42	10.42	10.81	10.67	10.43	9.40
Depth to Product	RW-1	ND	ND	ND	ND	ND	NM	NM
	RW-2	ND	ND	ND	ND	ND	ND	ND
	RW-3	10.28	10.42	10.57	11.43	9.84	10.18	9.36
	RW-4	9.64	9.73	9.76	9.94	9.28	9.56	8.33
	RW-5	NM	ND	NM	NM	NM	ND	ND
	RW-6	8.42	8.48	8.52	8.53	8.57	8.37	7.38
	RW-7	7.97	8.03	8.05	8.09	8.11	7.99	7.06
	RW-8	8.71	8.76	8.81	8.87	8.85	8.78	7.48
	RW-9	ND	ND	ND	ND	ND	ND	ND
Product Thickness	RW-1	ND	ND	ND	ND	ND	NM	NM
	RW-2	ND	ND	ND	ND	ND	ND	ND
	RW-3	0.57	0.45	0.25	0.65	2.29	1.71	0.47
	RW-4	0.19	0.03	0.23	0.17	0.08	0.26	0.32
	RW-5	NM	ND	NM	NM	NM	ND	ND
	RW-6	0.32	0.17	0.29	0.18	0.16	0.12	0.06
	RW-7	0.17	0.14	0.16	0.21	0.26	0.15	0.16
	RW-8	0.60	0.57	0.61	0.54	0.48	0.24	0.41
	RW-9	ND	ND	ND	ND	ND	ND	ND

NM = Not Measured

ND = Not Detected

Units are in feet.

System operation for the fourth quarter of 2005.

Table 4: Summary of Product Thickness Measurements and Operation and Maintenance Activities - First Semi-Annual 2006
Port of Oakland Harbor Facilities Center
2277 and 2225 7th Street, Oakland, California

Site Visit Date:2/3/2006					
Recovery Well	Depth to Product (feet)	Depth to Water (feet)	Product Thickness (feet)	Product Volume (gallons)	Comments
RW-1	--	--	--	--	Silt grading activities being performed on-site so did not check this vault
RW-2	None	7.66	--	--	No pump
RW-3	8.35	8.70	0.35	0.06	
RW-4	7.73	7.75	0.02	0.003	Air inlet and exhaust tubing disconnected from pump, significant water in vault (1/2 full), lots of biogrowth on outside of pump
RW-5	None	6.88	NA	NA	No cap and no pump
RW-6	7.35	7.39	0.04	0.01	Pumping but looks like only water, vault 1/2 full of water.
RW-7	7.02	7.09	0.07	0.01	Pumping but looks like only water.
RW-8	7.92	8.00	0.08	0.01	Pumping but no product in line, vault 1/2 full of water.
RW-9	None	9.21	NA	NA	No pump
Depth of product in convault			0.11 feet		
Approximate volume recovered			29 gallons		

Site Visit Date:2/8/2006					
Recovery Well	Depth to Product (feet)	Depth to Water (feet)	Product Thickness (feet)	Product Volume (gallons)	Comments
RW-1	None	6.4	NA	NA	Pulled pump out, put cap on well.
RW-2	--	--	NA	NA	
RW-3	8.50	8.80	0.3	0.05	Kinked discharge line, put piece of 3/4-inch hose around the tubing to provide support.
RW-4	7.74	7.76	0.02	0.003	Exhaust valve stuck open, put back pressure on valve and it began working.
RW-5	--	--	NA	NA	Put cap on well
RW-6	7.26	7.33	0.07	0.01	Pumping but looks like only water, vault 1/2 full of water.
RW-7	6.94	7.01	0.07	0.01	
RW-8	7.68	7.70	0.02	0.00	Exhaust valve stuck open, put back pressure on valve and it began working.
RW-9	--	--	NA	NA	Put cap on well
Depth of product in convault			0.11 feet		
Approximate volume recovered			29 gallons		

**Table 4: Summary of Product Thickness Measurements
and Operation and Maintenance Activities - First Semi-Annual 2006
Port of Oakland Harbor Facilities Center
2277 and 2225 7th Street, Oakland, California**

Site Visit Date:3/3/2006					
Recovery Well	Depth to Product (feet)	Depth to Water (feet)	Product Thickness (feet)	Product Volume (gallons)	Comments
RW-1	--	--	NA	NA	
RW-2	--	--	NA	NA	
RW-3	8.15	8.16	0.01	0.00	
RW-4	7.12	7.13	0.01	0.002	
RW-5	--	--	NA	NA	
RW-6	7.37	7.41	0.04	0.01	
RW-7	6.95	7.04	0.09	0.01	
RW-8	7.71	7.80	0.09	0.01	
RW-9	--	--	NA	NA	
Depth of product in convault			0.12 feet		
Approximate volume recovered			31 gallons		

Site Visit Date:3/10/2006					
Recovery Well	Depth to Product (feet)	Depth to Water (feet)	Product Thickness (feet)	Product Volume (gallons)	Comments
RW-1	--	--	NA	NA	
RW-2	--	--	NA	NA	
RW-3	7.90	7.92	0.02	0.00	Replace tubing with more flexible tube to reduce kinking
RW-4	--	--	NA	NA	
RW-5	--	--	NA	NA	
RW-6	7.14	7.15	0.01	0.00	
RW-7	--	--	NA	NA	
RW-8	--	--	NA	NA	
RW-9	--	--	NA	NA	
Depth of product in convault			0.12 feet		
Approximate volume recovered			31 gallons		

**Table 4: Summary of Product Thickness Measurements
and Operation and Maintenance Activities - First Semi-Annual 2006
Port of Oakland Harbor Facilities Center
2277 and 2225 7th Street, Oakland, California**

Site Visit Date:3/22/2006					
Recovery Well	Depth to Product (feet)	Depth to Water (feet)	Product Thickness (feet)	Product Volume (gallons)	Comments
RW-1	--	--	NA	NA	
RW-2	--	--	NA	NA	
RW-3	8.13	8.14	0.01	0.00	
RW-4	7.09	7.10	0.01	0.002	
RW-5	--	--	NA	NA	
RW-6	7.05	7.06	0.01	0.00	Replace tubing with more flexible tube to reduce kinking.
RW-7	6.70	6.71	0.01	0.00	
RW-8	None	7.43	NA	NA	
RW-9	--	--	NA	NA	
Depth of product in convault			0.14 feet		
Approximate volume recovered			37 gallons		

Site Visit Date:3/22/2006					
Recovery Well	Depth to Product (feet)	Depth to Water (feet)	Product Thickness (feet)	Product Volume (gallons)	Comments
RW-1	--	--	NA	NA	
RW-2	--	--	NA	NA	
RW-3	8.13	8.14	0.01	0.00	
RW-4	7.09	7.10	0.01	0.002	
RW-5	--	--	NA	NA	
RW-6	7.05	7.06	0.01	0.00	Replace tubing with more flexible tube to reduce kinking.
RW-7	6.70	6.71	0.01	0.00	
RW-8	None	7.43	NA	NA	
RW-9	--	--	NA	NA	
Depth of product in convault			0.14 feet		
Approximate volume recovered			37 gallons		

Table 4: Summary of Product Thickness Measurements and Operation and Maintenance Activities - First Semi-Annual 2006
Port of Oakland Harbor Facilities Center
2277 and 2225 7th Street, Oakland, California

Date: 4/4/06					
Recovery Well	Depth to Product	Depth to Water	Product Thickness	Product Volume	Comments:
	feet	feet	feet	gallons	
RW-1	--	--	--	--	
RW-2	--	--	--	--	
RW-3	6.94	6.95	0.01	0.00	Utility box over half full of runoff water, water dripping inside well from leaking vacuum pipe
RW-4	--	--	NA	NA	Utility box full of runoff water
RW-5	--	--	--	--	
RW-6	6.84	6.85	0.01	0.00	
RW-7	6.44	6.45	0.01	0.00	
RW-8	None	7.35		--	
RW-9	--	--	--	--	
Depth of product in convault			0.14 feet		
Approximate volume recovered			37 gallons		

Date: 4/7/06					
Recovery Well	Depth to Product	Depth to Water	Product Thickness	Product Volume	Comments:
	feet	feet	feet	gallons	
RW-1	--	--	--	--	
RW-2	--	--	--	--	
RW-3	7.38	7.39	0.01	0.00	Installed temporary rubber seal around utility box lid to reduce surface water intrusion
RW-4	6.35	6.37	0.02	0.003	Installed temporary rubber seal around utility box lid to reduce surface water intrusion
RW-5	--	--	--	--	
RW-6	6.80	6.81	0.01	0.00	
RW-7	6.40	6.41	0.01	0.00	
RW-8	None	7.22		--	
RW-9	--	--	--	--	
Depth of product in convault			0.14 feet		
Approximate volume recovered			37 gallons		

Table 4: Summary of Product Thickness Measurements and Operation and Maintenance Activities - First Semi-Annual 2006
Port of Oakland Harbor Facilities Center
2277 and 2225 7th Street, Oakland, California

Date: 4/28/06					
Recovery Well	Depth to Product	Depth to Water	Product Thickness	Product Volume	Comments:
	feet	feet	feet	gallons	
RW-1	--	--	--	--	
RW-2	--	--	--	--	
RW-3	8.09	8.10	0.01	0.00	
RW-4	6.75	6.75	0	0.000	
RW-5	--	--	--	--	
RW-6	6.90	6.90	0	0.00	Some water in vault. Water in discharge line, replaced pump with spare.
RW-7	6.50	6.50	0	0.00	
RW-8	7.27	7.27		--	
RW-9	--	--	--	--	
Depth of product in convault			0.15 feet		
Approximate volume recovered			39 gallons		

Date: 4/23/06					
Recovery Well	Depth to Product	Depth to Water	Product Thickness	Product Volume	Comments:
	feet	feet	feet	gallons	
RW-1	--	--	--	--	
RW-2	--	--	--	--	
RW-3	8.85	8.97	0.12	0.02	
RW-4	7.52	7.52	0	0.000	
RW-5	--	--	--	--	
RW-6	7.25	7.80	0.55	0.09	
RW-7	6.85	6.86	0.01	0.00	
RW-8	7.63	7.63		--	
RW-9	--	--	--	--	
Depth of product in convault			0.16 feet		
Approximate volume recovered			42 gallons		

Table 4: Summary of Product Thickness Measurements and Operation and Maintenance Activities - First Semi-Annual 2006
Port of Oakland Harbor Facilities Center
2277 and 2225 7th Street, Oakland, California

Date: 6/6/06					
Recovery Well	Depth to Product	Depth to Water	Product Thickness	Product Volume	Comments:
	feet	feet	feet	gallons	
RW-1	--	--	--	--	
RW-2	--	--	--	--	
RW-3	9.05	9.16	0.11	0.02	Removed all product in well then tuned off pump to RW-3 to do product recovery test.
RW-4	7.74	7.75	0.01	0.002	
RW-5	--	--	--	--	
RW-6	7.32	7.69	0.37	0.06	H ₂ O in product line, turned on pump, cleaned filter w/pressure washer, reinstalled filter.
RW-7	--	6.95	--	--	Observed product and H ₂ O in line, turned pump on blowing bubbles. Washed off filter and reinstalled with same results. Replaced pump with spare.
RW-8	--	7.70	--	--	
RW-9	--	--	--	--	
Depth of product in convault			0.17 feet		
Approximate volume recovered			45 gallons		

Date: 6/27/06					
Recovery Well	Depth to Product	Depth to Water	Product Thickness	Product Volume	Comments:
	feet	feet	feet	gallons	
RW-1	--	--	--	--	
RW-2	--	--	--	--	
RW-3	9.29	9.30	0.01	0.00	Slowed down pump rate.
RW-4	--	8.07	--	--	No product, left inactive.
RW-5	--	--	--	--	
RW-6	7.53	7.62	0.09	0.01	Pumping water, replaced filter but did not work., replaced pump with spare.
RW-7	7.11	7.12	0.01	0.00	Lowered pump.
RW-8	--	7.87	--	--	Lowered pump.
RW-9	--	--	--	--	
Depth of product in convault			0.25 feet		
Approximate volume recovered			65 gallons		

**Table 4: Summary of Product Thickness Measurements
and Operation and Maintenance Activities - First Semi-Annual 2006
Port of Oakland Harbor Facilities Center
2277 and 2225 7th Street, Oakland, California**

Date: 7/31/06					
Recovery Well	Depth to Product feet	Depth to Water feet	Product Thickness feet	Product Volume gallons	Comments:
RW-1	--	--	--	--	
RW-2	--	--	--	--	
RW-3	9.64	9.68	0.04	0.01	Began pilot test by applying a low vacuum to well head.
RW-4	--	--	--	--	
RW-5	--	--	--	--	
RW-6	--	7.74	--	--	Began pilot test by applying a low vacuum to well head.
RW-7	--	--	--	--	
RW-8	--	--	--	--	
RW-9	--	--	--	--	
Depth of product in convault			0.25 feet		
Approximate volume recovered			65 gallons		

Notes:

See Figure 2 for recovery well locations.

-- = not measured

NA = not applicable

TABLE 4: Product Thickness Measurements and Operations and Maintenance Activities - August to December 2006
Port of Oakland Harbor Facilities Center
2277 and 2225 7th Street, Oakland, California

Site Visit Date: 8/18/2006				
Recovery Well	Depth to Product (feet)	Depth to Water (feet)	Product Thickness (feet)	Comments
RW-1	--	--	--	On-going construction. No access.
RW-2	--	9.93	--	
RW-3	--	9.89	--	Little product in line. No water. Pump currently cycling.
RW-4	8.03	8.04	0.01	
RW-5	--	--	--	No access, vehicle parked on top of lid.
RW-6	--	7.88	--	Little water in the line.
RW-7	7.40	7.50	0.10	Product/ little water in line. Turned pump on; product only pumping.
RW-8	--	8.21	--	No product.
RW-9	--	--	--	Capped too tight.
Depth of product in convault: 0.24 foot Approximate total volume recovered: 63 gallons				

Site Visit Date: 8/25/2006				
Recovery Well	Depth to Product (feet)	Depth to Water (feet)	Product Thickness (feet)	Comments
RW-1	--	7.65	--	
RW-2	--	10.00	--	
RW-3	9.91	9.92	0.01	Product in line. Pump turned on. Little product in line. Skimmer pump is at 10 feet below top of casing.
RW-4	--	9.09	--	Product in line.
RW-5	--	--	--	Vehicle parked on vault cover.
RW-6	--	7.98	--	No product in line.
RW-7	7.48	7.55	0.07	Product in line. Turned pump on; product and little water in line.
RW-8	--	8.29	--	No product in line.
RW-9	--	9.81	--	
Depth of product in convault: 0.24 foot Approximate total volume recovered: 63 gallons				

TABLE 4: Product Thickness Measurements and Operations and Maintenance Activities - August to December 2006
Port of Oakland Harbor Facilities Center
2277 and 2225 7th Street, Oakland, California

Site Visit Date: 9/1/2006				
Recovery Well	Depth to Product (feet)	Depth to Water (feet)	Product Thickness (feet)	Comments
RW-1	--	7.79	--	No measurable product.
RW-2	--	10.07	--	No measurable product.
RW-3	10.08	10.09	0.01	Product in line. Pump turned on; no product in line.
RW-4	--	9.24	--	No product or water in line. Pump turned on; no product or water in line. Pump was set to inactive.
RW-5	--	--	--	Inaccessible. Port truck parked on recovery well location.
RW-6	--	8.13	--	No measurable product. No product in line. Pump turned on; water being pumped.
RW-7	7.59	7.64	0.05	Product in line. Pump turned on; product only being pumped.
RW-8	--	8.42	--	No measurable product. Water in line. Pump turned on; product and water in line. Pump was set to inactive.
RW-9	--	9.87	--	Measurable products.
Depth of product in convault: 0.24 foot				
Approximate total volume recovered: 63 gallons				

Site Visit Date: 9/8/2006				
Recovery Well	Depth to Product (feet)	Depth to Water (feet)	Product Thickness (feet)	Comments
RW-1	--	7.84	--	
RW-2	--	10.16	--	
RW-3	10.13	10.15	0.02	Cycle on-going. Product in line. Pump turned on after cycle has stopped. Product and air being pumped.
RW-4	--	9.30	--	Product in line.
RW-5	--	7.97	--	No measurable product.
RW-6	8.27	8.31	0.04	Pump turned on. Bubbles observed in line. Change pump settings from off to Duration 15 minutes and Period of 1 day. Little water and product in line.
RW-7	7.71	7.72	0.01	Product in line. Pump turned on.
RW-8	8.52	8.64	0.12	Product and water in line. Pumped turned on; water only being pumped. Pump was jiggled and was blowing air after.
RW-9	--	9.92	--	
Depth of product in convault: 0.24 foot				
Approximate total volume recovered: 63 gallons				

TABLE 4: Product Thickness Measurements and Operations and Maintenance Activities - August to December 2006
Port of Oakland Harbor Facilities Center
2277 and 2225 7th Street, Oakland, California

Site Visit Date: 9/15/2006				
Recovery Well	Depth to Product (feet)	Depth to Water (feet)	Product Thickness (feet)	Comments
RW-1	--	--	--	
RW-2	--	--	--	
RW-3	10.10	10.14	0.04	Product in line. Pump was not turned on.
RW-4	--	9.37	--	No product or water in line. Air in line.
RW-5	--	8.08	--	
RW-6	8.37	8.42	0.05	Product in line. Pump turned on. Product only being pumped.
RW-7	7.81	7.82	0.01	Product in line. Pump turned on. Product only being pumped.
RW-8	8.60	8.89	0.29	Product and air in line. Turned on pump. After pumping for 5 minutes, product level dropped approximately 0.01 ft.
RW-9	--	--	--	
Depth of product in convault:			NA	
Approximate total volume recovered:			NA	

Site Visit Date: 9/22/2006				
Recovery Well	Depth to Product (feet)	Depth to Water (feet)	Product Thickness (feet)	Comments
RW-1	--	--	--	
RW-2	--	--	--	
RW-3	10.22	10.23	0.01	Product and water in line. Pump turned on; product and little water being pumped. Pump was jiggled and more product was observed in the line.
RW-4	9.37	9.38	0.01	No product in line. Pump turned on; product in line.
RW-5	--	--	--	
RW-6	8.46	8.52	0.06	Product in line. Pump was turned on. Product being pumped. Water also in line.
RW-7	--	7.88	--	Product in line. Pump was turned on. Air in line.
RW-8	8.70	8.85	0.15	Product in line. Pump turned on; product only being pumped.
RW-9	--	--	--	
Depth of product in convault:			0.26 foot	
Approximate total volume recovered:			68 gallons	

TABLE 4: Product Thickness Measurements and Operations and Maintenance Activities - August to December 2006
Port of Oakland Harbor Facilities Center
2277 and 2225 7th Street, Oakland, California

Site Visit Date: 9/29/2006				
Recovery Well	Depth to Product	Depth to Water	Product Thickness	Comments:
	feet	feet	feet	
RW-1	--	--	--	
RW-2	--	--	--	
RW-3	10.38	10.39	0.01	Product in line.
RW-4	--	9.54	--	No product in line. Pump turned on for 3 minutes; air only being pumped.
RW-5	--	--	--	
RW-6	8.55	8.57	0.02	Product with little water in line. Pump was turned on for 3 minutes; air only being pumped.
RW-7	--	7.95	--	Product in line. Pump turned on for 3 minutes; air only being pumped.
RW-8	8.79	8.93	0.14	No product in line. Pump turned on for 3 minutes; air only being pumped.
RW-9	--	--	--	
Depth of product in convault: 0.26 foot				
Approximate total volume recovered: 68 gallons				

Site Visit Date: 10/3/2006				
Recovery Well	Depth to Product	Depth to Water	Product Thickness	Comments:
	feet	feet	feet	
RW-1	--	--	--	Well was not inspected.
RW-2	--	--	--	Well was not inspected.
RW-3	--	--	--	Well was not inspected.
RW-4	--	--	--	Well was not inspected.
RW-5	--	--	--	Well was not inspected.
RW-6	--	--	--	Well was not inspected.
RW-7	--	--	--	Well was not inspected.
RW-8	8.78	8.92	0.14	Product line full of water. Pulled pump and replaced filter (black thick sludge covering filter). Pump assembly was pressured washed.
RW-9	--	--	--	Well was not inspected.
Depth of product in convault: NA				
Approximate total volume recovered: NA				

TABLE 4: Product Thickness Measurements and Operations and Maintenance Activities - August to December 2006
Port of Oakland Harbor Facilities Center
2277 and 2225 7th Street, Oakland, California

Site Visit Date: 10/6/2006				
Recovery Well	Depth to Product	Depth to Water	Product Thickness	Comments:
	feet	feet	feet	
RW-1	--	--	--	
RW-2	--	--	--	
RW-3	10.37	10.38	0.01	Product in line. Pump assembly was removed and washed. Pump turned on; only air being pumped.
RW-4	--	9.54	--	No product in line. Pump assembly was removed and washed. Pumped was turned on; air only being pumped.
RW-5	--	--	--	
RW-6	8.58	8.60	0.02	Product in line. Pump assembly was removed and washed. Pump turned on; product only being pumped.
RW-7	--	8.05	--	Standing water in vault. Product in line. Pump assembly was pulled out and washed. Pump turned on; product only being pumped.
RW-8	--	8.87	--	Water in line. No product. Pump assembly was pulled out and washed. Replaced float. Pump turned on; no product, only air being pumped.
RW-9	--	--	--	
Depth of product in convault: 0.32 foot				
Approximate total volume recovered: 84 gallons				

Site Visit Date: 10/13/2006				
Recovery Well	Depth to Product	Depth to Water	Product Thickness	Comments:
	feet	feet	feet	
RW-1	--	--	--	
RW-2	--	--	--	
RW-3	10.35	10.36	0.01	Little water in line. Ran pump, no water pumping; just air.
RW-4	--	9.57	--	No product in line. Pump was turned on; air only being pumped.
RW-5	--	--	--	
RW-6	8.62	8.64	0.02	Product in line. Ran pump, just product and air in line.
RW-7	--	8.04	--	Product in line. Pump air only.
RW-8	8.90	8.90	--	Air in product line only. Ran pump; only air being pumped.
RW-9	--	--	--	
Depth of product in convault: 0.33 foot				
Approximate total volume recovered: 86 gallons				

TABLE 4: Product Thickness Measurements and Operations and Maintenance Activities - August to December 2006
Port of Oakland Harbor Facilities Center
2277 and 2225 7th Street, Oakland, California

Site Visit Date: 10/20/2006				
Recovery Well	Depth to Product	Depth to Water	Product Thickness	Comments:
	feet	feet	feet	
RW-1	--	--	--	
RW-2	--	--	--	
RW-3	10.65	10.66	0.01	Pump was set to inactive. Product observed in line.
RW-4	--	9.87	--	Pump was set to inactive. No product observed in line.
RW-5	--	--	--	
RW-6	8.72	8.74	0.02	Pump was set to inactive. Product was observed in line.
RW-7	--	8.17	--	Pump was set to inactive. No product observed in line.
RW-8	9.02	9.03	0.01	Pump was set to inactive. Product in line.
RW-9	--	--	--	
Depth of product in convault: 0.32 foot				
Approximate total volume recovered: 84 gallons				

Site Visit Date: 11/2/2006				
Recovery Well	Depth to Product	Depth to Water	Product Thickness	Comments:
	feet	feet	feet	
RW-1	--	--	--	
RW-2	--	--	--	
RW-3	10.65	10.67	0.02	Utility box was dry. Pump was not activated.
RW-4	--	9.71	--	Water observed in utility box. Pump was not activated.
RW-5	--	--	--	
RW-6	8.75	8.84	0.09	Utility box was dry. Pump was not activated. Pump was turned on; observed product being pumped.
RW-7	--	8.20	--	Rain water was observed in utility box. Pump was not activated.
RW-8	9.04	9.06	0.02	Utility box is dry. Pump was not activated.
RW-9	--	--	--	
Depth of product in convault: 0.32 foot				
Approximate total volume recovered: 84 gallons				

TABLE 4: Product Thickness Measurements and Operations and Maintenance Activities - August to December 2006
Port of Oakland Harbor Facilities Center
2277 and 2225 7th Street, Oakland, California

Site Visit Date: 11/15/2006				
Recovery Well	Depth to Product	Depth to Water	Product Thickness	Comments:
	feet	feet	feet	
RW-1	--	--	--	
RW-2	--	--	--	
RW-3	10.47	10.50	0.03	Utility box was dry. Pump turned on; only air being pumped. Pump was activated.
RW-4	--	9.62	--	Utility box was dry. Pump turned on; only air being pumped. Pump was not activated.
RW-5	--	--	--	
RW-6	8.72	8.80	0.08	Utility box is dry. Pump turned on. Product being pumped. Pump was activated.
RW-7	--	9.12	--	Standing water inside utility box. Pump turned on; only air being pumped. Pump was not activated.
RW-8	9.04	9.07	0.03	Utility box is dry. Pump turned on. Product being pumped. Pump was activated.
RW-9	--	--	--	
Depth of product in convault: 0.36 foot				
Approximate total volume recovered: 94 gallons				

Site Visit Date: 11/29/2006				
Recovery Well	Depth to Product	Depth to Water	Product Thickness	Comments:
	feet	feet	feet	
RW-1	--	8.06	--	Well head box soon to be raised to recent grade change elevation.
RW-2	--	10.27	--	Capped.
RW-3	10.78	10.86	0.08	Air and product in line.
RW-4	--	9.99	--	Air only in line.
RW-5	--	8.49	--	Capped well head.
RW-6	8.85	8.94	0.09	Air and product in line.
RW-7	--	8.26	--	Air only in product line.
RW-8	9.12	9.22	0.10	Air and product in line.
RW-9	--	10.24	--	Capped well head.
Depth of product in convault: 0.36 foot				
Approximate total volume recovered: 94 gallons				

TABLE 4: Product Thickness Measurements and Operations and Maintenance Activities - August to December 2006
Port of Oakland Harbor Facilities Center
2277 and 2225 7th Street, Oakland, California

Site Visit Date: 12/11/2006				
Recovery Well	Depth to Product	Depth to Water	Product Thickness	Comments:
	feet	feet	feet	
RW-1	--	--	--	
RW-2	--	--	--	
RW-3	10.50	10.55	0.05	Utility box was dry. Product observed in line.
RW-4	--	9.74	--	Utility box was dry. No product in line. Pump turned on; air only being pumped.
RW-5	--	--	--	
RW-6	8.76	8.90	0.14	Utility box has water. Product in line. Pump turned on; product only being pumped.
RW-7	--	8.22	--	Utility box was dry. No product in line. Pump turned on; air only being pumped.
RW-8	9.12	9.21	0.09	Utility box was dry. Product in line. Pump turned on; product only being pumped.
RW-9	--	--	--	
Depth of product in convault: 0.38 foot				
Approximate total volume recovered: 99 gallons				

Site Visit Date: 12/19/2006				
Recovery Well	Depth to Product	Depth to Water	Product Thickness	Comments:
	feet	feet	feet	
RW-1	--	--	--	
RW-2	--	--	--	
RW-3	10.17	10.20	0.03	Product and water in line. Turned pump on; pumping mostly water. Pulled pump; changed filter and washed pump. Skimmer pump pumped water for about 3 minutes then just product.
RW-4	--	9.41	--	Pump was set to inactive.
RW-5	--	--	--	
RW-6	8.70	8.71	0.01	Product in line. Turned on pump; product only being pumped. Utility box is half full of water.
RW-7	--	8.10	--	Pump was set to inactive.
RW-8	9.01	9.10	0.09	Air in line. Turned on pump; product only being pumped.
RW-9	--	--	--	
Depth of product in convault: 0.4 foot				
Approximate total volume recovered: 105 gallons				

TABLE 4: Product Thickness Measurements and Operations and Maintenance Activities - August to December 2006
Port of Oakland Harbor Facilities Center
2277 and 2225 7th Street, Oakland, California

Site Visit Date: 12/27/2006				
Recovery Well	Depth to Product	Depth to Water	Product Thickness	Comments:
	feet	feet	feet	
RW-1	--	--	--	
RW-2	--	--	--	
RW-3	9.62	9.68	0.06	Water in line. Removed pump and replaced with spare pump. Cleaned previously installed pump. Started spare pump; product and air only being pumped.
RW-4	9.19	9.22	0.03	Air only in line.
RW-5	--	--	--	
RW-6	--	8.67	--	Product and air in line. Utility box is half full of water.
RW-7	8.06	8.07	0.01	Air only in line. Utility box contains water.
RW-8	9.01	9.02	0.01	Line contains air and some product. Water also noted inside the utility box.
RW-9	--	--	--	
Depth of product in convault:			0.43 foot	
Approximate total volume recovered:			113 gallons	

Notes:

See Figure 2 for recovery well locations.

-- = not measured.

NA = not applicable or available.

**TABLE 3: Product Thickness Measurements and Operations and Maintenance Activities - January through June 2007
Harbor Facilities Center and Portion of Shippers Transport Express Leasehold**

Site Visit Date: 1/5/2007				
Recovery Well	Depth to Product (feet)	Depth to Water (feet)	Product Thickness (feet)	Comments
RW-1	--	--	--	
RW-2	--	--	--	
RW-3	10.43	10.47	0.04	Product and air in line only. Turned on pump, only product and air being pumped.
RW-4	9.56	9.57	0.01	
RW-5	--	--	--	
RW-6	8.72	8.76	0.04	Product and air only in line. Turned on pump, only product and air being pumped.
RW-7	8.12	8.13	0.01	Product and air only in line. Turned on pump, only product and air being pumped.
RW-8	9.04	9.08	0.04	Product and air only in line. Turned on pump, only product and air being pumped.
RW-9	--	--	--	
MW-3	10.41	10.98	0.57	Removed 1.25 gallons of mostly product, placed into convault.
Depth of product in convault			0.43 feet	
Approximate total volume recovered			113 gallons	

Site Visit Date: 1/12/2007				
Recovery Well	Depth to Product (feet)	Depth to Water (feet)	Product Thickness (feet)	Comments
RW-1	--	8.02	--	Vault is dry.
RW-2	--	9.84	--	
RW-3	10.42	10.43	0.01	Pump turned on; product being pumped. Vault is dry.
RW-4	--	9.61	--	Vault is dry. Pump turned on; only air being pumped. Pump set to inactive.
RW-5	--	--	--	No access.
RW-6	8.79	8.80	0.01	Vault has water. Pump turned on; product being pumped.
RW-7	--	8.19	--	Vault is dry. Pump turned on; air only being pumped. Pump set to inactive.
RW-8	9.07	9.15	0.08	Air and product in line. Pump turned on; product being pumped. Vault is dry.
RW-9	--	9.96	--	Vault is dry.
MW-3	10.44	10.97	0.53	Removed ~ 1.25 gallons of mostly product from well, placed into convault.
Depth of product in convault			0.44 feet	
Approximate total volume recovered			114 gallons	

**TABLE 3: Product Thickness Measurements and Operations and Maintenance Activities - January through June 2007
Harbor Facilities Center and Portion of Shippers Transport Express Leasehold**

Site Visit Date: 1/19/2007				
Recovery Well	Depth to Product (feet)	Depth to Water (feet)	Product Thickness (feet)	Comments
RW-1	--	--	--	
RW-2	--	--	--	
RW-3	10.55	10.56	0.01	Vault is dry. Product observed in line. Pump turned on. Product only being pumped.
RW-4	--	9.71	--	Vault is dry. Pump set to inactive.
RW-5	--	--	--	
RW-6	--	8.82	--	Water noted inside the vault. Product observed in line. Pump turned on. Product being pumped.
RW-7	--	8.24	--	Vault is dry. Pump set to inactive.
RW-8	9.10	9.13	0.03	Vault is dry. Product observed in line. Pump turned on. Product being pumped.
RW-9	--	--	--	
MW-3	10.54	11.21	0.67	Purged ~ 2.0 gallons of product, placed into convault..
Depth of product in convault			0.44 feet	
Approximate total volume recovered			115 gallons	

Site Visit Date: 1/26/2007				
Recovery Well	Depth to Product (feet)	Depth to Water (feet)	Product Thickness (feet)	Comments
RW-1	--	--	--	
RW-2	--	--	--	
RW-3	10.58	10.59	0.01	Vault is dry; observed product in product line; pump turned on, product only being pumped.
RW-4	--	9.76	--	Vault is dry. Pump set to inactive.
RW-5	--	--	--	No measurable product.
RW-6	8.84	8.85	0.01	being pumped.
RW-7	--	8.27	--	Vault is dry. Pump set to inactive.
RW-8	9.14	9.20	0.06	Vault is dry; product observed in product line; pump turned on, product being pumped.
RW-9	--	--	--	
MW-3	10.61	11.24	0.63	Purged ~ 2.5 gallons of product, placed into convault.
Depth of product in convault			0.45	
Approximate total volume recovered			118	

**TABLE 3: Product Thickness Measurements and Operations and Maintenance Activities - January through June 2007
Harbor Facilities Center and Portion of Shippers Transport Express Leasehold**

Site Visit Date: 2/1/2007				
Recovery Well	Depth to Product (feet)	Depth to Water (feet)	Product Thickness (feet)	Comments
RW-1	--	--	--	
RW-2	--	--	--	
RW-3	10.65	10.66	0.01	Little product in line, no water, lowered skimmer to 10, cycled pump for 5 minutes. No water pumping.
RW-4	Sheen	9.84	Sheen	Pump set to inactive.
RW-5	--	--	--	
RW-6	8.85	8.89	0.04	Little product in line, no water, lowered skimmer to 9 ft., cycled pump for 5 minutes. Water being pumped, changed out filter to new.
RW-7	None	8.28	None	Pump set to inactive.
RW-8	9.15	9.23	0.08	Little product in line, no water, cycled pump. Product being pumped only.
RW-9	--	--	--	
MW-3	10.64	11.40	0.76	Purged ~ 4 gallons of liquid, placed into convault..
Depth of product in convault			0.45 feet	
Approximate total volume recovered			118 gallons	

Site Visit Date: 2/9/2007				
Recovery Well	Depth to Product (feet)	Depth to Water (feet)	Product Thickness (feet)	Comments
RW-1	--	--	--	
RW-2	--	--	--	
RW-3	9.86	9.87	0.01	Water observed in vault. Product observed in line. Pump turned on; water being pumped. Depth-to-pump was adjusted from 10 to 9 feet. Water still being pumped. Skimmer pump pressure washed; replaced hydrophobic filter; pump depth was set to 9; pumping air and little water.
RW-4	--	9.57	--	Water observed in vault. Pump set to inactive.
RW-5	--	--	--	
RW-6	8.80	8.81	0.01	Vault contains water; product and water in line.
RW-7	--	8.25	--	Half of vault is filled with water. Pump set to inactive.
RW-8	9.16	9.23	0.07	Vault contained water; product observed in line; pump turned on; product being pumped.
RW-9	--	--	--	
MW-3	9.94	11.15	1.21	~ 4 gallons of product were purged, placed into convault..
Depth of product in convault			0.46 feet	
Approximate total volume recovered			120 gallons	

**TABLE 3: Product Thickness Measurements and Operations and Maintenance Activities - January through June 2007
Harbor Facilities Center and Portion of Shippers Transport Express Leasehold**

Site Visit Date: 2/13/2007				
Recovery Well	Depth to Product (feet)	Depth to Water (feet)	Product Thickness (feet)	Comments
RW-1	--	--	--	
RW-2	--	--	--	
RW-3	9.78	10.96	1.18	Utility box is dry; no product in product line; pump turned on; product only being pumped. Depth-to-pump was re-adjusted 9 feet; air only being pumped. Product thickness is greater than last visit.
RW-4	Sheen	9.22	Sheen	Utility vault is dry; water level is higher by 0.35' compared to last visit. Pump set to inactive.
RW-5				
RW-6	8.65	8.77	0.12	Utility box contains water; product observed in line; depth-to-pump was adjusted to 8 feet; pump turned on; product being pumped.
RW-7		8.10		Pump set to inactive.
RW-8	9.05	9.09	0.04	Little water observed in utility box; product observed in product line; water level is 0.14 higher compared to last visit; pump turned on; only air being pumped. Product thickness is less than last visit.
RW-9				
MW-3	9.84	10.89	1.05	Depth-to-water is 0.26 foot higher; ~ 4.0 gallons of mostly product were purged, placed into convault.
Depth of product in convault			0.48 feet	
Approximate total volume recovered			126 gallons	

Site Visit Date: 2/15/2007				
Recovery Well	Depth to Product (feet)	Depth to Water (feet)	Product Thickness (feet)	Comments
RW-1	--	--	--	
RW-2	--	--	--	
RW-3	10.27	10.28	0.01	Utility box is dry; product observed in product line; pump turned on; product being pumped. Water level is 0.68 foot higher compared to last visit.
RW-4	Sheen	9.42	Sheen	Utility is dry; water level is lower by 0.20 foot compared to last visit. Pump set to inactive.
RW-5	--	--	--	
RW-6	8.69	8.73	0.04	Utility box contains water; product observed in line; pump turned on; product being pumped. Water level is 0.04 foot higher compared to last visit.
RW-7	--	8.13	--	Utility box is dry; water level is lower by 0.03 foot compared to last visit. Pump set to inactive.
RW-8	9.05	9.06	0.01	Utility box is dry; no product observed in product line; water level is 0.03 foot lower compared to last visit.
RW-9	--	--	--	Pump turned on; only air being pumped.
MW-3	10.27	10.7	0.43	Water level is lower by 0.43 foot compared to last visit. ~ 2.0 gallons of product were purged, placed into convault..
Depth of product in convault			0.50 feet	
Approximate total volume recovered			131 gallons	

**TABLE 3: Product Thickness Measurements and Operations and Maintenance Activities - January through June 2007
Harbor Facilities Center and Portion of Shippers Transport Express Leasehold**

Site Visit Date: 2/23/2007				
Recovery Well	Depth to Product (feet)	Depth to Water (feet)	Product Thickness (feet)	Comments
RW-1	--	7.63	--	
RW-2	--	9.38	--	
RW-3	10.04	10.05	0.01	Utility vault is dry; water and product observed in line. Water level is 0.23 foot higher compared to last visit. Skimmer pump lowered to 10 feet; pumping water; pump raised to 9 feet; pumping air; replaced skimmer pump with pump from RW-4; pumping air.
RW-4	--	9.45		Utility vault is dry; water level is 0.03' lower compared to last visit; skimmer pump removed from well.
RW-5	--	--	--	No access.
RW-6	8.72	8.90	0.18	Utility vault contains water; observed product in line; water level is 0.17 foot lower compared to last visit. Pump turned on; product being pumped.
RW-7	--	8.16	--	Utility vault contains water; water level is 0.03 foot lower compared to last visit; skimmer pump removed from well.
RW-8	9.07	9.09	0.02	Utility vault contains water; product observed in product line; pump turned on; product being pumped. Water level is 0.03 foot lower compared to last visit.
RW-9	--	9.88	--	
MW-3	10.06	10.94	0.88	Water level is 0.24' lower compared to last visit. ~ 3 gallons of liquid was purged, placed into convault..
Depth of product in convault			0.52 feet	
Approximate total volume recovered			136 gallons	

Site Visit Date: 3/2/2007				
Recovery Well	Depth to Product (feet)	Depth to Water (feet)	Product Thickness (feet)	Comments
RW-1	--	--	--	
RW-2	--	--	--	
RW-3	10.13	10.14	0.01	Little water in line once pump activated. Ran pump for 10 minutes; mostly air with some product pumped.
RW-4	--	9.25	--	Vault is dry.
RW-5	--	--	--	
RW-6	8.61	8.80	0.19	Air and product in line; no water; vault half full of water.
RW-7	--	8.01	--	
RW-8	8.97	8.98	0.01	Air, little product in line. Vault is dry.
RW-9	--	--	--	
MW-3	10.1	10.65	0.55	Removed 4 gallons of mostly product, placed into convault..
Depth of product in convault			0.54 feet	
Approximate total volume recovered			141 gallons	
Note: Bled water from compressor; check compressor oil level.				

**TABLE 3: Product Thickness Measurements and Operations and Maintenance Activities - January through June 2007
Harbor Facilities Center and Portion of Shippers Transport Express Leasehold**

Site Visit Date: 3/9/2007				
Recovery Well	Depth to Product (feet)	Depth to Water (feet)	Product Thickness (feet)	Comments
RW-1	--	--	--	
RW-2	--	--	--	
RW-3	--	10.25	--	Product observed in line; pulled the skimmer pump; surge blocked the well; pump was not replaced to allow settlement of sediments. Pump set to inactive.
RW-4	--	--	--	
RW-5	--	--	--	
RW-6	8.41	8.45	0.04	Pump turned on; product only being pumped. Product thickness decreased to 0.02 after 10 minutes.
RW-7	--	--	--	
RW-8	9.00	9.01	0.01	Pump turned on; product only being pumped.
RW-9	--	--	--	
MW-3	10.25	10.67	0.42	~ 3 gallons were purged, placed into convault..
Depth of product in convault			0.54 feet	
Approximate total volume recovered			141 gallons	Note:

Site Visit Date: 3/13/2007				
Recovery Well	Depth to Product (feet)	Depth to Water (feet)	Product Thickness (feet)	Comments
RW-1	--	--	--	
RW-2	--	--	--	
RW-3	10.32	10.34	0.02	Accumulation of product after well was surge blocked on 3/9/07. Left skimmer pump out. Will check product level next event.
RW-4	--	--	--	
RW-5	--	--	--	
RW-6	--	--	--	
RW-7	--	--	--	
RW-8	--	--	--	
RW-9	--	--	--	
MW-3	10.29	10.73	0.44	Removed ~ 2 gallons of mostly product, placed into convault..
Depth of product in convault			0.55 feet	
Approximate total volume recovered			144 gallons	

**TABLE 3: Product Thickness Measurements and Operations and Maintenance Activities - January through June 2007
Harbor Facilities Center and Portion of Shippers Transport Express Leasehold**

Site Visit Date: 3/16/2007				
Recovery Well	Depth to Product (feet)	Depth to Water (feet)	Product Thickness (feet)	Comments
RW-1	--	--	--	
RW-2	--	--	--	
RW-3	10.42	10.46	0.04	Installed pump #7; product thickness was skimmed for about 15 minutes after which air was observed. Air observed in product line. Water level is 0.21 foot lower compared to last visit. Pump was set to period = 7; duration = 30.
RW-4	--	--	--	
RW-5	--	--	--	
RW-6	8.75	8.81	0.06	Product observed in line. Pump turned on. Product being pumped. Water level is 0.36 foot lower compared to last visit.
RW-7	--	--	--	
RW-8	9.03	9.04	0.01	No product observed in line. Pump turned on; product being pumped. Water level is 0.03 foot lower compared to last visit.
RW-9	--	--	--	
MW-3	10.37	10.85	0.48	~ 1.0 gallon of liquid purged, placed into convault..
Depth of product in convault			0.59 feet	
Approximate total volume recovered			154 gallons	

Site Visit Date: 3/22/2007				
Recovery Well	Depth to Product (feet)	Depth to Water (feet)	Product Thickness (feet)	Comments
RW-1	--	--	--	
RW-2	--	--	--	
RW-3	10.47	Sheen		
RW-4	--	--	--	
RW-5	--	--	--	
RW-6	8.76	8.86	0.10	Pump turned on; product being pumped.
RW-7	--	--	--	
RW-8	9.04	9.08	0.04	Pump turned on; product being pumped.
RW-9	--	--	--	
MW-3	10.43	10.98	--	~ 2.0 gallons of product were purged, placed into convault.
Depth of product in convault			0.59 feet	
Approximate total volume recovered			154 gallons	

**TABLE 3: Product Thickness Measurements and Operations and Maintenance Activities - January through June 2007
Harbor Facilities Center and Portion of Shippers Transport Express Leasehold**

Site Visit Date: 3/28/2007				
Recovery Well	Depth to Product (feet)	Depth to Water (feet)	Product Thickness (feet)	Comments
RW-1	--	8.06	--	
RW-2	--	9.85	--	
RW-3	10.71	10.72	0.01	Product observed in line.
RW-4	--	9.83	--	
RW-5	--	8.49	--	
RW-6	8.81	8.88	0.07	Product observed in line.
RW-7	--	8.24	--	
RW-8	9.11	9.17	0.06	Product observed in line.
RW-9	--	9.93	--	
MW-3	10.59	11.45	0.86	~ 1.5.0 gallons of product purged, placed into convault.
Depth of product in convault			0.59 feet	
Approximate total volume recovered			154 gallons	
Note: Shut-off entire system for pump controller software upgrade.				

Site Visit Date: 4/3/2007				
Recovery Well	Depth to Product (feet)	Depth to Water (feet)	Product Thickness (feet)	Comments
RW-1	--	--	--	
RW-2	--	--	--	
RW-3	10.67	10.68	0.01	
RW-4	--	--	--	
RW-5	--	--	--	
RW-6	8.82	8.97	0.15	
RW-7	--	--	--	
RW-8	9.12	19.19	0.07	
RW-9	--	--	--	
MW-3	10.6	11.48	0.88	Purged ~ 1.5 gallons of liquid, placed into convault..
Depth of product in convault			0.60 feet	
Approximate total volume recovered			157 gallons	
Note: Reinstalled pump controller.				

**TABLE 3: Product Thickness Measurements and Operations and Maintenance Activities - January through June 2007
Harbor Facilities Center and Portion of Shippers Transport Express Leasehold**

Site Visit Date: 4/13/2007				
Recovery Well	Depth to Product (feet)	Depth to Water (feet)	Product Thickness (feet)	Comments
RW-1	--	--	--	
RW-2	--	--	--	
RW-3	10.20	10.35	0.15	
RW-4	--	--	--	Old brass ball valve; not tapped for vacuum valve.
RW-5	--	--	--	
RW-6	8.88	8.94	0.06	
RW-7	--	--	--	Old brass ball valve; tapped for vacuum valve
RW-8	9.17	9.27	0.10	Older brass gate valve; not tapped for vacuum valve.
RW-9	--	--	--	
MW-3	10.75	11.57	0.82	Purged ~ 2.0 gallons of product, placed into convault..
Depth of product in convault			0.61 feet	
Approximate total volume recovered			160 gallons	Note: Made inventory of existing plumbing at recovery wells.

Site Visit Date: 4/18/2007				
Recovery Well	Depth to Product (feet)	Depth to Water (feet)	Product Thickness (feet)	Comments
RW-1	--	--	--	
RW-2	--	--	--	
RW-3	--	--	--	
RW-4	--	--	--	
RW-5	--	--	--	
RW-6	--	--	--	
RW-7	--	--	--	
RW-8	--	--	--	
RW-9	--	--	--	
MW-3	--	--	--	Removed 2 gallons and placed into convault.
Depth of product in convault			0.61 feet	
Approximate total volume recovered			160 gallons	Note: Skimmer system was turned off for installation of low-vacuum blower.

**TABLE 3: Product Thickness Measurements and Operations and Maintenance Activities - January through June 2007
Harbor Facilities Center and Portion of Shippers Transport Express Leasehold**

Site Visit Date: 4/25/2007				
Recovery Well	Depth to Product (feet)	Depth to Water (feet)	Product Thickness (feet)	Comments
RW-1	--	8.1	--	
RW-2	--	--	--	
RW-3	10.72	10.82	0.10	
RW-4	9.74	9.75	0.01	
RW-5	--	8.41	--	
RW-6	8.92	9.03	0.11	
RW-7	8.65	8.65	Sheen	
RW-8	9.34	9.42	0.08	
RW-9	--	9.94	--	
MW-3	--	--	--	
Depth of product in convault			0.61 feet	
Approximate total volume recovered			160 gallons	

Site Visit Date: 5/3/2007				
Recovery Well	Depth to Product (feet)	Depth to Water (feet)	Product Thickness (feet)	Comments
RW-1	--	--	--	
RW-2	--	--	--	
RW-3	10.71	10.81	0.10	
RW-4	--	--	--	
RW-5	--	--	--	
RW-6	8.82	8.92	0.01	
RW-7	--	--	--	
RW-8	9.25	9.31	0.06	
RW-9	--	--	--	
MW-3	10.63	11.54	0.91	Removed 1.5 gallons of product and placed into convault.
Depth of product in convault			0.64 feet	
Approximate total volume recovered			166 gallons	

**TABLE 3: Product Thickness Measurements and Operations and Maintenance Activities - January through June 2007
Harbor Facilities Center and Portion of Shippers Transport Express Leasehold**

Site Visit Date: 5/18/2007				
Recovery Well	Depth to Product (feet)	Depth to Water (feet)	Product Thickness (feet)	Comments
RW-1	--	--	--	
RW-2	--	--	--	
RW-3	10.80	10.81	0.01	Product observed in line.
RW-4	--	--	--	
RW-5	--	--	--	
RW-6	8.86	8.91	0.05	
RW-7	--	--	--	
RW-8	9.13	9.17	0.04	
RW-9	--	--	--	
MW-3	10.7	11.55	0.85	Pumped ~ 3.0 gallons of product, placed into convault.
Depth of product in convault			0.64 feet	
Approximate total volume recovered			166 gallons	

Site Visit Date: 5/25/2007				
Recovery Well	Depth to Product (feet)	Depth to Water (feet)	Product Thickness (feet)	Comments
RW-1	--	--	--	
RW-2	--	--	--	
RW-3	10.80	10.81	0.01	Product in line.
RW-4	10.03	10.05	0.02	
RW-5	--	--	--	
RW-6	8.87	8.91	0.04	Product and water in line.
RW-7	8.30	8.31	0.01	
RW-8	9.15	9.20	0.05	Product observed in line.
RW-9	--	--	--	
MW-3	10.72	11.57	0.85	Purged ~ 2.0 gallons of product, placed into convault.
Depth of product in convault			0.64 feet	
Approximate total volume recovered			166 gallons	Note: Removed oxygen releasing compound socks from MW-4. Dissolved oxygen in groundwater is 8.79 mg/L.

**TABLE 3: Product Thickness Measurements and Operations and Maintenance Activities - January through June 2007
Harbor Facilities Center and Portion of Shippers Transport Express Leasehold**

Site Visit Date: 6/8/2007				
Recovery Well	Depth to Product (feet)	Depth to Water (feet)	Product Thickness (feet)	Comments
RW-1				
RW-2				
RW-3	10.5	10.51	0.01	
RW-4	9.77	9.80	0.03	
RW-5				
RW-6	8.65	8.82	0.17	
RW-7	8.39	8.42	0.03	
RW-8	9.10	9.25	0.15	
RW-9				
MW-3	10.71	11.17	0.46	Pumped out product on 6/6/07. ~ 2.0 gallons; again on 6/8/07 ~ 1.0 gallon. Placed product into convault.
Depth of product in convault			0.64 feet	
Approximate total volume recovered			166 gallons	

Notes:

See Figure 2 for recovery well locations.

-- = not measured.

Sheen = less than 0.01 foot thickness of product.

Product purging in MW-3 is conducted using a peristaltic pump.

TABLE 3: Product Thickness Measurements and Operations and Maintenance Activities - July through December 2007
Port of Oakland
651 and 555 Maritime Street
Oakland, California

Site Visit Date: 7/6/2007						
Recovery Well	Depth to Product (feet)	Depth to Water (feet)	Product Thickness (feet)	Cycles/Period and Duration	Vacuum (Inches of H2O)	Comments
RW-1	--	--	--	Off	Off	
RW-2	--	--	--	Off	Off	
RW-3	10.86	10.91	0.05	P=1;D=10	Off	
RW-4	10.10	10.35	0.25	P=1;D=10	Off	
RW-5	--	--	--	Off	Off	
RW-6	9.19	9.45	0.26	P=1;D=10	Off	
RW-7	8.36	8.44	0.08	P=7;D=10	Off	
RW-8	9.03	9.40	0.37	P=1;D=10	Off	
RW-9	--	--	--	Off	Off	
MW-3	--	--	--	NA	NA	
Depth to product in Convault			1.80	feet		
Approximate total volume recovered			175	gallons		

Site Visit Date: 7/26/2007						
Recovery Well	Depth to Product (feet)	Depth to Water (feet)	Product Thickness (feet)	Cycles/Period and Duration	Vacuum (Inches of H2O)	Comments
RW-1	--	--	--	Off	Off	Six new carbon canisters delivered to site.
RW-2	--	--	--	Off	Off	
RW-3	--	--	--	P=1;D=10	Off	
RW-4	--	--	--	P=1;D=10	Off	
RW-5	--	--	--	Off	Off	
RW-6	--	--	--	P=1;D=10	Off	
RW-7	--	--	--	P=7;D=10	Off	
RW-8	--	--	--	P=1;D=10	Off	
RW-9	--	--	--	Off	Off	
MW-3	--	--	--	NA	NA	
Depth to product in Convault			1.79	feet		
Approximate total volume recovered			178	gallons		

TABLE 3: Product Thickness Measurements and Operations and Maintenance Activities - July through December 2007
Port of Oakland
651 and 555 Maritime Street
Oakland, California

Site Visit Date: 8/2/2007						
Recovery Well	Depth to Product (feet)	Depth to Water (feet)	Product Thickness (feet)	Cycles/Period and Duration	Vacuum (Inches of H2O)	Comments
						Installed four carbon canisters to vacuum system discharge line. Started vacuum system.
RW-1	--	--	--	Off	Off	
RW-2	--	--	--	Off	Off	
RW-3	11.00	11.05	0.05	P=7;D=10	11.0	
RW-4	10.29	10.38	0.09	P=1;D=10	Off	
RW-5	--	--	--	Off	Off	
RW-6	9.10	9.48	0.38	P=1;D=10	Off	
RW-7	--	--	--	P=7;D=10	Off	
RW-8	9.25	9.57	0.32	P=7;D=10	11.0	
RW-9	--	--	--	Off	Off	
MW-3	10.94	11.86	0.92	NA	NA	
Depth to product in Convault			1.79	feet		
Approximate total volume recovered			178	gallons		

Site Visit Date: 8/10/2007						
Recovery Well	Depth to Product (feet)	Depth to Water (feet)	Product Thickness (feet)	Cycles/Period and Duration	Vacuum (Inches of H2O)	Comments
RW-1	--	--	--	Off	Off	
RW-2	--	--	--	Off	Off	
RW-3	10.50	10.52	0.02	P=7;D=10	11.0	
RW-4	--	--	--	P=1;D=10	Off	
RW-5	--	--	--	Off	Off	
RW-6	--	--	--	P=1;D=10	Off	
RW-7	--	--	--	P=7;D=10	Off	
RW-8	9.04	9.58	0.54	P=1;D=15	8.0	
RW-9	--	--	--	Off	Off	
MW-3	--	--	--	NA	NA	
Depth to product in Convault			1.80	feet		
Approximate total volume recovered			175	gallons		

TABLE 3: Product Thickness Measurements and Operations and Maintenance Activities - July through December 2007
Port of Oakland
651 and 555 Maritime Street
Oakland, California

Site Visit Date: 8/17/2007						
Recovery Well	Depth to Product (feet)	Depth to Water (feet)	Product Thickness (feet)	Cycles/Period and Duration	Vacuum (Inches of H2O)	Comments
						Changed out two down stream carbon canisters on the vacuum system.
RW-1	--	--	--	Off	Off	
RW-2	--	--	--	Off	Off	
RW-3	10.45	10.55	0.10	P=7;D=10	11.0	
RW-4	--	--	--	P=1;D=10	Off	
RW-5	--	--	--	Off	Off	
RW-6	--	--	--	P=1;D=10	Off	
RW-7	--	--	--	P=7;D=10	Off	
RW-8	8.96	9.32	0.36	P=1;D=15	8.0	
RW-9	--	--	--	Off	Off	
MW-3	--	--	--	NA	NA	
Depth to product in Convault			1.78	feet		
Approximate total volume recovered			181	gallons		

Site Visit Date: 8/23/2007						
Recovery Well	Depth to Product (feet)	Depth to Water (feet)	Product Thickness (feet)	Cycles/Period and Duration	Vacuum (Inches of H2O)	Comments
RW-1	--	--	--	Off	Off	
RW-2	--	--	--	Off	Off	
RW-3	10.52	10.54	0.02	P=7;D=10	11.0	
RW-4	--	--	--	P=1;D=10	Off	
RW-5	--	--	--	Off	Off	
RW-6	8.99	9.51	0.52	P=1;D=10	Off	
RW-7	--	--	--	P=7;D=10	Off	
RW-8	9.16	9.66	0.50	P=1;D=15	8.0	Vacuum at 5 inches of H2O before adjusting to 10.5 in/H2O.
RW-9	--	--	--	Off	Off	
MW-3	--	--	--	NA	NA	
Depth to product in Convault			1.77	feet		
Approximate total volume recovered			183	gallons		

TABLE 3: Product Thickness Measurements and Operations and Maintenance Activities - July through December 2007
Port of Oakland
651 and 555 Maritime Street
Oakland, California

Site Visit Date: 8/29/2007						
Recovery Well	Depth to Product (feet)	Depth to Water (feet)	Product Thickness (feet)	Cycles/Period and Duration	Vacuum (Inches of H2O)	Comments
RW-1	--	--	--	Off	Off	
RW-2	--	--	--	Off	Off	
RW-3	11.04	11.07	0.03	P=7;D=10	Off	Turned off vacuum to well due do little response.
RW-4	10.27	10.41	0.14	P=7;D=10	Off	
RW-5	--	--	--	Off	Off	
RW-6	8.84	9.43	0.59	P=1;D=15	10.0	Turned vacuum on to well set to 10 in/H2O.
RW-7	8.28	8.70	0.42	P=3;D=10	10.0	Turned vacuum on to well set to 10 in/H2O.
RW-8	9.19	9.80	0.61	P=1;D=15	10.0	Vacuum at 8.4 in/H2O adjusted to 10 in/H2O. Started skimmer, little product being pumped, replaced filter, more being pumped.
RW-9	--	--	--	Off	Off	
MW-3	10.90	11.80	0.90	NA	NA	
Depth to product in Convault			1.77	feet		
Approximate total volume recovered			183	gallons		

Site Visit Date: 9/7/2007						
Recovery Well	Depth to Product (feet)	Depth to Water (feet)	Product Thickness (feet)	Cycles/Period and Duration	Vacuum (Inches of H2O)	Comments
RW-1	--	--	--	Off	Off	
RW-2	--	--	--	Off	Off	
RW-3	--	--	--	P=7;D=10	Off	
RW-4	--	--	--	P=7;D=10	Off	
RW-5	--	--	--	Off	Off	
RW-6	8.81	9.84	1.03	P=1;D=15	8.0	Vacuum at 7.5 in/H2O adjusted to 8 in/H2O.
RW-7	8.45	8.75	0.30	P=3;D=10	9.0	Vacuum at 8 in/H2O adjusted to 9 in/H2O.
RW-8	9.60	9.80	0.20	P=1;D=10	9.0	Vacuum at 17 in/H2O adjusted to 9. in/H2O.
RW-9	--	--	--	Off	Off	
MW-3	--	--	--	NA	NA	
Depth to product in Convault			1.75	feet		
Approximate total volume recovered			188	gallons		

TABLE 3: Product Thickness Measurements and Operations and Maintenance Activities - July through December 2007
Port of Oakland
651 and 555 Maritime Street
Oakland, California

Site Visit Date: 9/14/2007						
Recovery Well	Depth to Product (feet)	Depth to Water (feet)	Product Thickness (feet)	Cycles/Period and Duration	Vacuum (Inches of H2O)	Comments
RW-1	--	--	--	Off	Off	
RW-2	--	--	--	Off	Off	
RW-3	--	--	--	P=7;D=10	Off	
RW-4	--	--	--	P=7;D=10	Off	
RW-5	--	--	--	Off	Off	
RW-6	8.69	8.79	0.10	P=1;D=15	7.2	Vacuum at 7.2 in/H2O.
RW-7	7.85	8.15	0.30	P=3;D=10	9.0	Vacuum at 9 in/H2O.
RW-8	9.20	9.60	0.40	P=1;D=10	12.0	Vacuum at 5.5 in/H2O, adjusted vacuum to 12 in/H2O. Turned on skimmer for 15 minutes, 1.5 cups of product generated.
RW-9	--	--	--	Off	Off	
MW-3	--	--	--	NA	NA	
Depth to product in Convault			1.73	feet		
Approximate total volume recovered			194	gallons		

Site Visit Date: 9/20/2007						
Recovery Well	Depth to Product (feet)	Depth to Water (feet)	Product Thickness (feet)	Cycles/Period and Duration	Vacuum (Inches of H2O)	Comments
RW-1	--	--	--	Off	Off	
RW-2	--	--	--	Off	Off	
RW-3	--	--	--	P=7;D=10	Off	
RW-4	--	--	--	P=7;D=10	Off	
RW-5	--	--	--	Off	Off	
RW-6	9.01	9.42	0.41	P=1;D=15	9.5	Vacuum at 6.9 in/H2O adjusted vacuum to 9. in/H2O.
RW-7	8.35	8.72	0.37	P=3;D=10	8.0	Vacuum at 6 in/H2O adjusted vacuum to 8. in/H2O.
RW-8	9.25	9.90	0.65	P=1;D=10	9.0	Vacuum at 16.5 in/H2O adjusted vacuum to 10. in/H2O.
RW-9	--	--	--	Off	Off	
MW-3	--	--	--	NA	NA	
Depth to product in Convault			1.71	feet		
Approximate total volume recovered			199	gallons		

TABLE 3: Product Thickness Measurements and Operations and Maintenance Activities - July through December 2007
Port of Oakland
651 and 555 Maritime Street
Oakland, California

Site Visit Date: 9/27/2007						
Recovery Well	Depth to Product (feet)	Depth to Water (feet)	Product Thickness (feet)	Cycles/Period and Duration	Vacuum (Inches of H2O)	Comments
						Changed out two down stream carbon canisters on the vacuum system.
RW-1	--	--	--	Off	Off	
RW-2	--	--	--	Off	Off	
RW-3	--	--	--	P=7;D=10	Off	
RW-4	--	--	--	P=7;D=10	Off	
RW-5	--	--	--	Off	Off	
RW-6	9.04	9.64	0.60	P=1;D=15	9.5	Vacuum at 7.5 adjusted vacuum to 9 in/H2O.
RW-7	8.46	8.83	0.37	P=3;D=10	8.0	Vacuum at 5 adjusted vacuum to 7.75 in/H2O.
RW-8	9.60	9.82	0.22	P=1;D=10	11.5	Vacuum at 2 adjusted vacuum to 11.5 in/H2O.
RW-9	--	--	--	Off	Off	
MW-3	--	--	--	NA	NA	
Depth to product in Convault			1.69	feet		
Approximate total volume recovered			204	gallons		

Site Visit Date: 10/4/2007						
Recovery Well	Depth to Product (feet)	Depth to Water (feet)	Product Thickness (feet)	Cycles/Period and Duration	Vacuum (Inches of H2O)	Comments
RW-1	--	--	--	Off	Off	
RW-2	--	--	--	Off	Off	
RW-3	--	--	--	P=7;D=10	Off	
RW-4	--	--	--	P=7;D=10	Off	
RW-5	--	--	--	Off	Off	
RW-6	8.96	9.46	0.50	P=1;D=15	10.0	Vacuum at 10. in/H2O.
RW-7	8.38	8.81	0.43	P=3;D=10	8.0	Vacuum at 8 in/H2O.
RW-8	9.47	9.91	0.44	P=1;D=10	9.0	Vacuum at >15 in/H2O adjusted vacuum to 9. in/H2O.
RW-9	--	--	--	Off	Off	
MW-3	--	--	--	NA	NA	
Depth to product in Convault			1.63	feet		
Approximate total volume recovered			220	gallons		

TABLE 3: Product Thickness Measurements and Operations and Maintenance Activities - July through December 2007
Port of Oakland
651 and 555 Maritime Street
Oakland, California

Site Visit Date: 10/11/2007						
Recovery Well	Depth to Product (feet)	Depth to Water (feet)	Product Thickness (feet)	Cycles/Period and Duration	Vacuum (Inches of H2O)	Comments
RW-1	--	--	--	Off	Off	
RW-2	--	--	--	Off	Off	
RW-3	--	--	--	P=7;D=10	Off	
RW-4	--	--	--	P=7;D=10	Off	
RW-5	--	--	--	Off	Off	
RW-6	8.85	10.15	1.30	P=1;D=15	10.2	Vacuum at 10.2 in/H2O, turned on skimmer, pumping very little product, replaced skimmer filter, pumping ok.
RW-7	8.29	8.89	0.60	P=3;D=10	11.4	Vacuum at 11.4 in/H2O, turned on skimmer, pumping very little product, picked up pump, pumping ok.
RW-8	9.44	9.91	0.47	P=1;D=10	9.1	Vacuum at 9.1 in/H2O, turned on skimmer, pumping very little product, replaced skimmer filter, pumping ok.
RW-9	--	--	--	Off	Off	
MW-3	--	--	--	NA	NA	
Depth to product in Convault			1.60	feet		
Approximate total volume recovered			228	gallons		

Site Visit Date: 10/17/2007						
Recovery Well	Depth to Product (feet)	Depth to Water (feet)	Product Thickness (feet)	Cycles/Period and Duration	Vacuum (Inches of H2O)	Comments
RW-1	--	--	--	Off	Off	
RW-2	--	--	--	Off	Off	
RW-3	--	--	--	P=7;D=10	Off	
RW-4	--	--	--	P=7;D=10	Off	
RW-5	--	--	--	Off	Off	
RW-6	8.72	10.40	1.68	P=1;D=15	10.0	Vacuum at 12.4 in/H2O adjusted to 10, turned on skimmer, pumping very little product, replaced skimmer with refurbished one, pumping ok.
RW-7	8.14	8.70	0.56	P=2;D=10	10.0	Vacuum at >15 in/H2O adjusted to 10, turned on skimmer, pumping very little product, picked up pump, pumping ok.
RW-8	9.34	9.55	0.21	P=1;D=10	8.8	Vacuum at 8.8 in/H2O, turned on skimmer, pumping product ok.
RW-9	--	--	--	Off	Off	
MW-3	--	--	--	NA	NA	
Depth to product in Convault			1.57	feet		
Approximate total volume recovered			236	gallons		

TABLE 3: Product Thickness Measurements and Operations and Maintenance Activities - July through December 2007
Port of Oakland
651 and 555 Maritime Street
Oakland, California

Site Visit Date: 10/25/2007						
Recovery Well	Depth to Product (feet)	Depth to Water (feet)	Product Thickness (feet)	Cycles/Period and Duration	Vacuum (Inches of H2O)	Comments
						Changed out two down stream carbon canisters on the vacuum system.
RW-1	--	--	--	Off	Off	
RW-2	--	--	--	Off	Off	
RW-3	--	--	--	P=7;D=10	Off	
RW-4	--	--	--	P=7;D=10	Off	
RW-5	--	--	--	Off	Off	
RW-6	8.98	9.55	0.57	P=1;D=15	12.6	Vacuum at 12.6 in/H2O adjusted to 10 in/H2O, water observed in product line, raised skimmer.
RW-7	8.34	9.25	0.91	P=2;D=15	9.0	Vacuum at 6.0 in/H2O adjusted to 9 in/H2O, turned on skimmer, pumping product ok.
RW-8	9.50	9.75	0.25	P=1;D=10	8.2	Vacuum at 8.2 in/H2O, turned on skimmer, pumping product ok.
RW-9	--	--	--	Off	Off	
MW-3	--	--	--	NA	NA	
Depth to product in Convault			1.52	feet		
Approximate total volume recovered			249	gallons		

Site Visit Date: 11/2/2007						
Recovery Well	Depth to Product (feet)	Depth to Water (feet)	Product Thickness (feet)	Cycles/Period and Duration	Vacuum (Inches of H2O)	Comments
RW-1	--	--	--	Off	Off	
RW-2	--	--	--	Off	Off	
RW-3	--	--	--	P=7;D=10	Off	
RW-4	--	--	--	P=7;D=10	Off	
RW-5	--	--	--	Off	Off	
RW-6	8.89	9.90	1.01	P=1;D=20	9.0	Vacuum at 9.0 in/H2O.
RW-7	8.32	9.24	0.92	P=1;D=15	5.0	Vacuum at 5.0 in/H2O.
RW-8	9.40	9.71	0.31	P=1;D=10	6.4	Vacuum at 6.4 in/H2O.
RW-9	--	--	--	Off	Off	
MW-3	--	--	--	NA	NA	
Depth to product in Convault			1.47	feet		
Approximate total volume recovered			262	gallons		

TABLE 3: Product Thickness Measurements and Operations and Maintenance Activities - July through December 2007
Port of Oakland
651 and 555 Maritime Street
Oakland, California

Site Visit Date: 11/8/2007						
Recovery Well	Depth to Product (feet)	Depth to Water (feet)	Product Thickness (feet)	Cycles/Period and Duration	Vacuum (Inches of H2O)	Comments
RW-1	--	--	--	Off	Off	
RW-2	--	--	--	Off	Off	
RW-3	--	--	--	P=7;D=10	Off	
RW-4	--	--	--	P=7;D=10	Off	
RW-5	--	--	--	Off	Off	
RW-6	8.95	9.95	1.00	C=2;D=15	8.8	Vacuum at 8.8 in/H2O.
RW-7	8.38	9.15	0.77	P=1;D=15	5.0	Vacuum at 5.0 in/H2O.
RW-8	9.43	9.72	0.29	P=1;D=10	9.0	Vacuum at 6 in/H2O, adjusted to in/H2O.
RW-9	--	--	--	Off	Off	
MW-3	--	--	--	NA	NA	
Depth to product in Convault			1.40	feet		
Approximate total volume recovered			280	gallons		

Site Visit Date: 11/15/2007						
Recovery Well	Depth to Product (feet)	Depth to Water (feet)	Product Thickness (feet)	Cycles/Period and Duration	Vacuum (Inches of H2O)	Comments
RW-1	--	--	--	Off	Off	
RW-2	--	--	--	Off	Off	
RW-3	--	--	--	P=7;D=10	Off	
RW-4	--	--	--	P=7;D=10	Off	
RW-5	--	--	--	Off	Off	
RW-6	9.00	9.80	0.80	C=3;D=15	10.0	Vacuum at 10 in/H2O.
RW-7	8.29	9.75	1.46	C=2;D=15	6.0	Vacuum at 6.0 in/H2O.
RW-8	9.45	9.80	0.35	P=1;D=10	10.0	Vacuum at 13 in/H2O, adjusted to 10 in/H2O.
RW-9	--	--	--	Off	Off	
MW-3	--	--	--	NA	NA	Purged ~ 6.5 gallons of product, placed into Convault.
Depth to product in Convault			1.35	feet		
Approximate total volume recovered			293	gallons		

TABLE 3: Product Thickness Measurements and Operations and Maintenance Activities - July through December 2007
Port of Oakland
651 and 555 Maritime Street
Oakland, California

Site Visit Date: 11/20/2007						
Recovery Well	Depth to Product (feet)	Depth to Water (feet)	Product Thickness (feet)	Cycles/Period and Duration	Vacuum (Inches of H2O)	Comments
RW-1	8.62	8.63	0.01	Off	Off	
RW-2	None	9.87	None	Off	Off	
RW-3	11.22	11.35	0.13	P=7;D=10	Off	
RW-4	10.34	10.65	0.31	P=1;D=10	Off	
RW-5	8.52	10.20	1.68	Off	Off	
RW-6	9.04	9.50	0.46	C=3;D=15	9.2	
RW-7	8.29	9.59	1.30	C=4;D=15	5.2	
RW-8	9.38	9.64	0.26	P=1;D=10	10.5	
RW-9	10.02	12.50	2.48	Off	Off	
MW-3	11.00	12.40	1.40	NA	NA	Purged ~ 6.0 gallons of product, placed into Convault.
Depth to product in Convault			1.25	feet		
Approximate total volume recovered			319	gallons		

Site Visit Date: 11/21/2007						
Recovery Well	Depth to Product (feet)	Depth to Water (feet)	Product Thickness (feet)	Cycles/Period and Duration	Vacuum (Inches of H2O)	Comments
RW-1	--	--	--	Off	Off	
RW-2	--	--	--	Off	Off	
RW-3	--	--	--	P=7;D=10	Off	
RW-4	--	--	--	P=1;D=10	Off	
RW-5	8.60	10.32	1.72	Off	Off	Purged ~ 3.0 gallons of product, placed into Convault.
RW-6	--	--	--	C=3;D=15	9.2	
RW-7	--	--	--	C=4;D=15	5.2	
RW-8	--	--	--	P=1;D=10	10.5	
RW-9	10.10	12.50	2.40	Off	Off	Purged ~ 3.0 gallons of product, placed into Convault.
MW-3	11.00	12.26	1.26	NA	NA	Purged ~ 1.5 gallons of product, placed into Convault.
Depth to product in Convault			--	feet		
Approximate total volume recovered			--	gallons		

TABLE 3: Product Thickness Measurements and Operations and Maintenance Activities - July through December 2007
Port of Oakland
651 and 555 Maritime Street
Oakland, California

Site Visit Date: 11/28/2007						
Recovery Well	Depth to Product (feet)	Depth to Water (feet)	Product Thickness (feet)	Cycles/Period and Duration	Vacuum (Inches of H2O)	Comments
						Breakthrough on carbon vessels, turn off low vacuum.
RW-1	--	--	--	Off	Off	
RW-2	None	10.10	None	Off	Off	
RW-3	11.32	11.49	0.17	P=7;D=10	Off	
RW-4	10.46	10.79	0.33	P=1;D=10	Off	
RW-5	8.80	8.95	0.15	Off	Off	
RW-6	9.15	9.53	0.38	C=3;D=15	Off	
RW-7	8.53	8.89	0.36	C=4;D=15	Off	
RW-8	9.45	9.60	0.15	P=1;D=10	Off	
RW-9	10.37	10.99	0.62	P=1;D=15	Off	Installed skimmer pump.
MW-3	11.11	12.67	1.56	NA	NA	Purged ~ 5 gallons of product, placed into Convault.
Depth to product in Convault			1.09	feet		
Approximate total volume recovered			361	gallons		

Site Visit Date: 12/07/2007						
Recovery Well	Depth to Product (feet)	Depth to Water (feet)	Product Thickness (feet)	Cycles/Period and Duration	Vacuum (Inches of H2O)	Comments
RW-1	--	--	--	Off	Off	
RW-2	None	9.55	None	Off	Off	
RW-3	10.91	11.06	0.15	P=7;D=10	Off	
RW-4	10.15	10.46	0.31	P=1;D=10	Off	
RW-5	8.68	8.79	0.11	Off	Off	
RW-6	9.20	9.34	0.14	C=3;D=15	Off	
RW-7	8.44	8.80	0.36	C=4;D=15	Off	
RW-8	9.70	10.00	0.30	P=1;D=10	Off	
RW-9	10.65	10.77	0.12	P=7;D=15	Off	Reduced skimmer activation from every day to once a week
MW-3	10.70	11.88	1.18	NA	NA	Purged ~ 4 gallons of product, placed into Convault.
Depth to product in Convault			1.05	feet		
Approximate total volume recovered			372	gallons	Product removed by Port waste disposal contractor.	

TABLE 3: Product Thickness Measurements and Operations and Maintenance Activities - July through December 2007
Port of Oakland
651 and 555 Maritime Street
Oakland, California

Site Visit Date: 12/14/2007						
Recovery Well	Depth to Product (feet)	Depth to Water (feet)	Product Thickness (feet)	Cycles/Period and Duration	Vacuum (Inches of H2O)	Comments
RW-1	--	--	--	Off	Off	
RW-2	None	9.61	None	Off	Off	
RW-3	11.24	11.40	0.16	P=7;D=10	Off	
RW-4	10.39	10.62	0.23	P=1;D=10	Off	
RW-5	8.85	9.00	0.15	Off	Off	
RW-6	9.29	9.45	0.16	C=3;D=15	Off	
RW-7	8.67	8.80	0.13	C=4;D=15	Off	
RW-8	9.71	10.17	0.46	P=1;D=10	Off	
RW-9	10.62	10.85	0.23	P=7;D=15	Off	
MW-3	11.06	12.26	1.20	NA	NA	Purged ~ 4 gallons of product, placed into Convault.
Depth to product in Convault			2.42	feet		
Approximate total volume recovered			13	gallons		

Site Visit Date: 12/21/2007						
Recovery Well	Depth to Product (feet)	Depth to Water (feet)	Product Thickness (feet)	Cycles/Period and Duration	Vacuum (Inches of H2O)	Comments
RW-1	--	--	--	Off	Off	
RW-2	None	10.10	None	Off	Off	
RW-3	10.91	11.22	0.31	P=7;D=10	Off	Cycled skimmer, product and air being pumped
RW-4	10.15	10.17	0.02	P=1;D=10	Off	Evidence of vaults being filled with rain water from storm run-off. Cycled skimmer, product and air being pumped
RW-5	8.63	8.82	0.19	Off	Off	
RW-6	9.12	9.25	0.13	C=3;D=15	Off	Cycled skimmer, product and air being pumped
RW-7	8.45	8.63	0.18	C=4;D=15	Off	Evidence of vaults being filled with rain water from storm run-off. Cycled skimmer, product and air being pumped
RW-8	9.65	9.90	0.25	P=1;D=10	Off	Cycled skimmer, product and air being pumped
RW-9	10.47	10.80	0.33	P=7;D=15	Off	Cycled skimmer, product being pumped
MW-3	10.71	11.59	0.88	NA	NA	Purged ~ 1.5 gallons of product, placed into Convault.
Depth to product in Convault			2.41	feet		
Approximate total volume recovered			16	gallons		

TABLE 3: Product Thickness Measurements and Operations and Maintenance Activities - July through December 2007
Port of Oakland
651 and 555 Maritime Street
Oakland, California

Site Visit Date: 12/28/2007						
Recovery Well	Depth to Product (feet)	Depth to Water (feet)	Product Thickness (feet)	Cycles/Period and Duration	Vacuum (Inches of H2O)	Comments
						Two 1,000 lbs carbon canisters installed to vacuum system discharge line. Started vacuum system.
RW-1	--	--	--	Off	Off	
RW-2	None	8.95	None	Off	Off	
RW-3	10.89	11.22	0.33	P=7;D=10	Off	
RW-4	10.00	10.03	0.03	P=1;D=10	Off	
RW-5	8.67	8.84	0.17	Off	Off	
RW-6	9.16	9.28	0.12	C=3;D=15	8.0	Applied vacuum to skimmer, adjusted vacuum to 8 in/H2O.
RW-7	8.51	8.98	0.47	C=4;D=15	7.4	Applied vacuum to skimmer, adjusted vacuum to 7.4 in/H2O.
RW-8	9.65	9.78	0.13	P=1;D=10	8.0	Applied vacuum to skimmer, adjusted vacuum to 8. in/H2O.
RW-9	10.40	11.15	0.75	P=7;D=15	Off	
MW-3	10.78	11.70	0.92	NA	NA	Purged ~ 4 gallons of product, placed into Convault.
Depth to product in Convault			2.38	feet		
Approximate total volume recovered			24	gallons		

Notes:

See Figure 2 for recovery well locations.

D= Duration (length of time in minutes the skimmer will run upon activation)

P= Period (P=1 would indicate skimmer activated every day; P=4 would be skimmer activated every fourth day)

C=Cycles (C=2 would indicate skimmer activated twice per day; C=4 would indicate skimmer activated four times per day)

H2O = water

lbs = pounds

-- = not measured.

Sheen = less than 0.01 foot thickness of product.

Product purging in is conducted using a peristaltic pump.

**TABLE 3: Product Thickness Measurements and
Operations and Maintenance Activities - January through June 2008**

Port of Oakland
651 and 555 Maritime Street
Oakland, California

Site Visit Date: 1/4/2008						
Recovery Well	Depth to Product (feet)	Depth to Water (feet)	Product Thickness (feet)	Cycles/Period and Duration	Vacuum (in. H ₂ O)	Comments
RW-1	--	--	--		Off	
RW-2	--	--	--		Off	
RW-3	10.90	11.83	0.93	P=7, D=10	Off	
RW-4	10.20	10.44	0.24	P=1, D=10	Off	
RW-5	8.79	8.89	0.10	Off	Off	
RW-6	9.20	9.36	0.16	C=3, D=15	Off	
RW-7	8.49	8.88	0.39	C=4, D=15	Off	
RW-8	9.70	10.00	0.30	P=1, D=10	Off	
RW-9	10.69	11.00	0.31	P=7, D=15	Off	
MW-3	10.75	11.41	0.66		Off	
Depth to product in Convault			1.12 feet	Depth to water in Convault		1.28 feet
Approximate total volume recovered			353 gallons	Volume of Product in Convault 42 gallons		
PID Readings on vapor:			Inlet: 40.9 ppmv	Midpoint: 0 ppmv	Final: 0 ppmv	

Site Visit Date: 1/11/2008						
Recovery Well	Depth to Product (feet)	Depth to Water (feet)	Product Thickness (feet)	Cycles/Period and Duration	Vacuum (in. H ₂ O)	Comments
RW-1					Off	
RW-2					Off	
RW-3	10.94	11.81	0.87	P=7, D=10	Off	
RW-4	10.19	10.47	0.28	P=1, D=10	Off	
RW-5	8.69	8.80	0.11	Off	Off	
RW-6	9.25	9.38	0.13	C=3, D=15	Off	
RW-7	8.46	8.88	0.42	C=4, D=15	Off	
RW-8	9.75	10.05	0.30	P=1, D=10	Off	
RW-9	10.68	10.79	0.11	P=1, P=7, D=15	Off	
MW-3	10.70	11.95	1.25		Off	Recovered 3 gal. of product.
Depth to product in Convault			1.13 feet	Depth to water in Convault		1.29 feet
Approximate total volume recovered			351 gallons	Volume of Product in Convault 42 gallons		
PID Readings on vapor:			Inlet: 40 ppmv	Midpoint: 0 ppmv	Final: 0 ppmv	

**TABLE 3: Product Thickness Measurements and
Operations and Maintenance Activities - January through June 2008**

Port of Oakland
651 and 555 Maritime Street
Oakland, California

Site Visit Date: 1/18/2008						
Recovery Well	Depth to Product (feet)	Depth to Water (feet)	Product Thickness (feet)	Cycles/Period and Duration	Vacuum (in. H ₂ O)	Comments
RW-1	--	--	--		Off	
RW-2	--	--	--		Off	
RW-3	10.90	11.86	0.96	P=7, D=10	Off	
RW-4	10.21	10.49	0.28	P=1, D=10	Off	
RW-5	8.70	8.81	0.11	Off	Off	
RW-6	9.29	9.36	0.07	C=3, D=15	Off	
RW-7	8.50	8.86	0.36	C=4, D=15	Off	
RW-8	9.79	10.15	0.36	P=1, D=10	Off	
RW-9	10.66	10.72	0.06	P=7, D=15	Off	
MW-3	10.79	11.98	1.19		Off	
Depth to product in Convault			1.13 feet	Depth to water in Convault		1.27 feet
Approximate total volume recovered			351 gallons	Volume of Product in Convault 37 gallons		
PID Readings on vapor:			Inlet: 48 ppmv	Midpoint: 0 ppmv	Final: 0 ppmv	

Site Visit Date: 1/25/2008						
Recovery Well	Depth to Product (feet)	Depth to Water (feet)	Product Thickness (feet)	Cycles/Period and Duration	Vacuum (in. H ₂ O)	Comments
RW-1	--	--	--		Off	
RW-2	--	--	--		Off	
RW-3	10.87	11.88	1.01	P=7, D=10	Off	
RW-4	10.24	10.51	0.27	P=1, D=10	Off	
RW-5	8.71	8.79	0.08	Off	Off	
RW-6	9.24	9.33	0.09	C=3, D=15	Off	
RW-7	8.47	8.81	0.34	C=4, D=15	Off	
RW-8	9.74	10.18	0.44	P=1, D=10	Off	
RW-9	10.69	10.79	0.10	P=7, D=15	Off	
MW-3	10.94	11.90	0.96		Off	
Depth to product in Convault			-- feet	Depth to water in Convault		-- feet
Approximate total volume recovered			-- gallons	Volume of Product in Convault -- gallons		
PID Readings on vapor:			Inlet: 48 ppmv	Midpoint: 0 ppmv	Final: 0 ppmv	

**TABLE 3: Product Thickness Measurements and
Operations and Maintenance Activities - January through June 2008**

Port of Oakland
651 and 555 Maritime Street
Oakland, California

Site Visit Date: 2/1/2008						
Recovery Well	Depth to Product (feet)	Depth to Water (feet)	Product Thickness (feet)	Cycles/Period and Duration	Vacuum (in. H ₂ O)	Comments
RW-1	--	--	--		Off	
RW-2	--	--	--		Off	
RW-3	10.77	11.91	1.14	P=7, D=10	Off	
RW-4	9.79	9.95	0.16	P=1, D=10	Off	
RW-5	8.00	8.17	0.17	Off	Off	
RW-6	8.24	8.41	0.17	C=3, D=15	Off	
RW-7	8.12	8.45	0.33	C=4, D=15	Off	
RW-8	9.71	10.00	0.29	P=1, D=10	Off	
RW-9	10.71	11.05	0.34	P=7, D=15	Off	
MW-3	10.86	11.91	1.05		Off	Unable to pump.
Depth to product in Convault			1.77 feet	Depth to water in Convault		1.95 feet
Approximate total volume recovered			183 gallons	Volume of Product in Convault 47 gallons		
PID Readings on vapor:			Inlet: 40 ppmv	Midpoint: 0 ppmv	Final: 0 ppmv	

Site Visit Date: 2/8/2008						
Recovery Well	Depth to Product (feet)	Depth to Water (feet)	Product Thickness (feet)	Cycles/Period and Duration	Vacuum (in. H ₂ O)	Comments
RW-1	--	--	--		Off	
RW-2	--	--	--		Off	
RW-3	10.70	11.94	1.24	P=7, D=10	Off	
RW-4	9.77	9.94	0.17	P=1, D=10	Off	
RW-5	8.20	8.36	0.16	Off	Off	
RW-6	8.21	8.38	0.17	C=3, D=15	Off	
RW-7	8.10	8.33	0.23	C=4, D=15	Off	
RW-8	8.65	8.74	0.09	P=1, D=10	Off	
RW-9	9.69	9.95	0.26	P=7, D=15	Off	
MW-3	10.71	11.20	0.49		Off	
Depth to product in Convault			-- feet	Depth to water		-- feet
Approximate total volume recovered			-- gallons	Volume of Product in Convault -- gallons		
PID Readings on vapor:			Inlet: 40 ppmv	Midpoint: 0 ppmv	Final: 0 ppmv	

**TABLE 3: Product Thickness Measurements and
Operations and Maintenance Activities - January through June 2008**

Port of Oakland
651 and 555 Maritime Street
Oakland, California

Site Visit Date: 2/15/2008											
Recovery Well	Depth to Product (feet)	Depth to Water (feet)	Product Thickness (feet)	Cycles/Period and Duration	Vacuum (in. H ₂ O)	Comments					
RW-1	--	--	--		Off						
RW-2	--	--	--		Off						
RW-3	10.71	11.86	1.15	P=7, D=10	Off						
RW-4	9.65	9.88	0.23	P=1, D=10	Off						
RW-5	8.81	8.89	0.08	Off	Off						
RW-6	8.23	8.41	0.18	C=3, D=15	Off						
RW-7	8.10	8.33	0.23	C=4, D=15	Off						
RW-8	8.71	8.78	0.07	P=1, D=10	Off						
RW-9	8.95	9.34	0.39	P=7, D=15	Off						
MW-3	10.79	11.24	0.45		Off						
Depth to product in Convault		--	feet	Depth to water in Convault		--	feet	Volume of Product in Convault		--	gallons
Approximate total volume recovered		--	gallons	PID Readings on vapor:		Inlet:	40 ppmv	Midpoint:	0 ppmv	Final:	0 ppmv

Site Visit Date: 2/25/2008											
Recovery Well	Depth to Product (feet)	Depth to Water (feet)	Product Thickness (feet)	Cycles/Period and Duration	Vacuum (in. H ₂ O)	Comments					
RW-1	--	--	--		Off						
RW-2	--	--	--		Off						
RW-3	9.41	13.25	3.84	P=7, D=10	Off						
RW-4	9.25	9.95	0.70	P=1, D=10	Off						
RW-5	--	--	--	Off	Off	Unable to check - truck parked on top.					
RW-6	8.12	8.20	0.08	C=3, D=15	Off						
RW-7	7.15	7.33	0.18	C=4, D=15	Off						
RW-8	7.25	7.55	0.30	P=1, D=10	Off	Need to fix petcock.					
RW-9	9.85	9.95	0.10	P=7, D=15	Off						
MW-3	--	--	--		Off	Truck parked on top. Returned to site 2/26 to pump well. Removed 17 gal.					
Depth to product in Convault		1.80	feet	Depth to water in Convault		2	feet	Volume of Product in Convault		52	gallons
Approximate total volume recovered		175	gallons	PID Readings on vapor:		Inlet:	40.6 ppmv	Midpoint:	0 ppmv	Final:	0 ppmv

**TABLE 3: Product Thickness Measurements and
Operations and Maintenance Activities - January through June 2008**

Port of Oakland
651 and 555 Maritime Street
Oakland, California

Site Visit Date: 2/28/2008						
Recovery Well	Depth to Product (feet)	Depth to Water (feet)	Product Thickness (feet)	Cycles/Period and Duration	Vacuum (in. H ₂ O)	Comments
RW-1	--	--	--		Off	
RW-2	--	--	--		Off	
RW-3	10.20	11.40	1.20	P=7, D=10	Off	
RW-4	9.29	9.95	0.66	P=1, D=10	Off	
RW-5	7.84	8.66	0.82	Off	Off	
RW-6	8.80	8.90	0.10	C=3, D=15	Off	
RW-7	7.29	7.56	0.27	C=4, D=15	Off	
RW-8	7.22	7.56	0.34	P=1, D=10	Off	
RW-9	9.80	9.95	0.15	P=7, D=15	Off	
MW-3	10.39	11.55	1.16		Off	
Depth to product in Convault			1.80 feet	Depth to water in Convault		2.00 feet
Approximate total volume recovered			175 gallons	Volume of Product in Convault 52 gallons		
PID Readings on vapor:			Inlet: 40.7 ppmv	Midpoint: 0 ppmv	Final: 0 ppmv	

Site Visit Date: 3/7/2008						
Recovery Well	Depth to Product (feet)	Depth to Water (feet)	Product Thickness (feet)	Cycles/Period and Duration	Vacuum (in. H ₂ O)	Comments
RW-1	--	--	--		Off	
RW-2	--	--	--		Off	
RW-3	10.27	12.15	1.88	P=7, D=10	Off	
RW-4		9.57		P=1, D=10	Off	
RW-5	8.20	8.75	0.55	Off	Off	
RW-6	8.00	8.15	0.15	C=3, D=15	Off	
RW-7	7.65	7.70	0.05	C=4, D=15	Off	
RW-8	8.30	8.35	0.05	P=1, D=10	Off	
RW-9	8.10	8.32	0.22	P=7, D=15	Off	
MW-3	--	--	--		Off	Truck parked on top of well.
Depth to product in Convault			1.79 feet	Depth to water in Convault		1.91 feet
Approximate total volume recovered			178 gallons	Volume of Product in Convault 31 gallons		
PID Readings on vapor:			Inlet: 40 ppmv	Midpoint: 0 ppmv	Final: 0 ppmv	

**TABLE 3: Product Thickness Measurements and
Operations and Maintenance Activities - January through June 2008**

Port of Oakland
651 and 555 Maritime Street
Oakland, California

Site Visit Date: 3/12/2008						
Recovery Well	Depth to Product (feet)	Depth to Water (feet)	Product Thickness (feet)	Cycles/Period and Duration	Vacuum (in. H ₂ O)	Comments
RW-1	--	--	--		Off	
RW-2	--	--	--		Off	
RW-3	10.22	12.19	1.97	P=7, D=10	Off	
RW-4	9.77	9.80	0.03	P=1, D=10	Off	
RW-5	8.21	8.79	0.58	Off	Off	
RW-6	8.01	8.14	0.13	C=3, D=15	Off	
RW-7	7.66	7.74	0.08	C=4, D=15	Off	
RW-8	7.21	7.39	0.18	P=1, D=10	Off	
RW-9	8.14	8.30	0.16	P=7, D=15	Off	
MW-3	--	--	--		Off	Truck parked on top of well.
Depth to product in Convault			1.79 feet	Depth to water in Convault		1.91 feet
Approximate total volume recovered			178 gallons	Volume of Product in Convault 31 gallons		
PID Readings on vapor:			Inlet: 40.6 ppmv	Midpoint: 0 ppmv	Final: 0 ppmv	

Site Visit Date: 3/21/2008						
Recovery Well	Depth to Product (feet)	Depth to Water (feet)	Product Thickness (feet)	Cycles/Period and Duration	Vacuum (in. H ₂ O)	Comments
RW-1	--	--	--		Off	
RW-2	--	--	--		Off	
RW-3	10.48	11.95	1.47	P=7, D=10	Off	
RW-4	9.78	9.81	0.03	P=1, D=10	Off	
RW-5	8.29	8.49	0.20	Off	Off	
RW-6	8.80	9.20	0.40	C=3, D=15	Off	
RW-7	8.10	8.29	0.19	C=4, D=15	Off	
RW-8	9.29	7.44	-1.85	P=1, D=10	Off	
RW-9	8.20	8.35	0.15	P=7, D=15	Off	
MW-3	--	--	--		Off	Truck parked on top of well.
Depth to product in Convault			1.79 feet	Depth to water in Convault		1.91 feet
Approximate total volume recovered			178 gallons	Volume of Product in Convault 31 gallons		
PID Readings on vapor:			Inlet: 40.6 ppmv	Midpoint: 0 ppmv	Final: 0 ppmv	

**TABLE 3: Product Thickness Measurements and
Operations and Maintenance Activities - January through June 2008**

Port of Oakland
651 and 555 Maritime Street
Oakland, California

Site Visit Date: 3/28/2008						
Recovery Well	Depth to Product (feet)	Depth to Water (feet)	Product Thickness (feet)	Cycles/Period and Duration	Vacuum (in. H ₂ O)	Comments
RW-1	--	--	--		Off	
RW-2	--	--	--		Off	
RW-3	10.55	11.75	1.20	P=7, D=10	Off	
RW-4	9.79	9.82	0.03	P=1, D=10	Off	
RW-5	8.30	8.50	0.20	Off	Off	
RW-6	8.80	9.25	0.45	C=3, D=15	Off	
RW-7	8.15	8.20	0.05	C=4, D=15	Off	
RW-8	9.30	9.40	0.10	P=1, D=10	Off	
RW-9	10.04	10.25	0.21	P=7, D=15	Off	Product in line, Station #2.
MW-3	--	--	--		Off	Truck parked on top of well.
Depth to product in Convault			1.78 feet	Depth to water in Convault		1.91 feet
Approximate total volume recovered			181 gallons	Volume of Product in Convault 34 gallons		
PID Readings on vapor:			Inlet: 21.9 ppmv	Midpoint: 0 ppmv	Final: 0 ppmv	Flowrate: 44 CFM

Site Visit Date: 4/4/2008						
Recovery Well	Depth to Product (feet)	Depth to Water (feet)	Product Thickness (feet)	Cycles/Period and Duration	Vacuum (in. H ₂ O)	Comments
RW-1	--	--	--		Off	
RW-2	--	--	--		Off	
RW-3	10.83	11.69	0.86	P=7, D=10	Off	
RW-4	9.93	10.24	0.31	P=1, D=10	Off	
RW-5	--	--	--	Off	Off	Truck parked on well vault
RW-6	8.31	9.15	0.84	C=3, D=15	Off	
RW-7	7.80	8.02	0.22	C=4, D=15	Off	
RW-8	8.99	9.10	0.11	P=1, D=10	Off	
RW-9	8.37	9.48	1.11	P=7, D=15	Off	
MW-3	--	--	--		Off	Truck parked on well vault
Depth to product in Convault			1.75 feet	Depth to water in Convault		1.91 feet
Approximate total volume recovered			189 gallons	Volume of Product in Convault 42 gallons		
PID Readings on vapor:			Inlet: 71.5 ppmv	Midpoint: 0 ppmv	Final: 0 ppmv	

**TABLE 3: Product Thickness Measurements and
Operations and Maintenance Activities - January through June 2008**

Port of Oakland
651 and 555 Maritime Street
Oakland, California

Site Visit Date: 4/11/2008						
Recovery Well	Depth to Product (feet)	Depth to Water (feet)	Product Thickness (feet)	Cycles/Period and Duration	Vacuum (in. H ₂ O)	Comments
RW-1	--	--	--		Off	
RW-2	--	--	--		Off	
RW-3	10.85	11.71	0.86	P=7, D=10	Off	
RW-4	9.95	10.26	0.31	P=1, D=10	Off	
RW-5	--	--	--	Off	Off	Truck parked on well vault
RW-6	8.33	9.17	0.84	C=3, D=15	Off	
RW-7	7.79	8.10	0.31	C=4, D=15	Off	
RW-8	8.95	9.09	0.14	P=1, D=10	Off	
RW-9	8.36	9.46	1.10	P=7, D=15	Off	
MW-3	10.77	11.54	0.77		Off	
Depth to product in Convault			1.77 feet	Depth to water in Convault		1.91 feet
Approximate total volume recovered			183 gallons	Volume of Product in Convault 37 gallons		
PID Readings on vapor:			Inlet: 68 ppmv	Midpoint: 0 ppmv	Final: 0 ppmv	

Site Visit Date: 4/18/2008						
Recovery Well	Depth to Product (feet)	Depth to Water (feet)	Product Thickness (feet)	Cycles/Period and Duration	Vacuum (in. H ₂ O)	Comments
RW-1	--	--	--		Off	
RW-2	--	--	--		Off	
RW-3	10.85	11.70	0.85	P=7, D=10	Off	
RW-4	10.00	10.25	0.25	P=1, D=10	Off	
RW-5	--	--	--	Off	Off	Truck parked on well vault
RW-6	8.33	9.17	0.84	C=3, D=15	11	Product in line
RW-7	7.75	7.80	0.05	C=4, D=15	15	
RW-8	8.98	9.10	0.12	P=1, D=10	14	
RW-9	8.35	9.42	1.07	P=7, D=15	Off	
MW-3	10.75	11.57	0.82		Off	
Depth to product in Convault			1.75 feet	Depth to water in Convault		1.90 feet
Approximate total volume recovered			189 gallons	Volume of Product in Convault 39 gallons		
PID Readings on vapor:			Inlet: ppmv	Midpoint: 0 ppmv	Final: 0 ppmv	

**TABLE 3: Product Thickness Measurements and
Operations and Maintenance Activities - January through June 2008**

Port of Oakland
651 and 555 Maritime Street
Oakland, California

Site Visit Date: 4/25/2008						
Recovery Well	Depth to Product (feet)	Depth to Water (feet)	Product Thickness (feet)	Cycles/Period and Duration	Vacuum (in. H ₂ O)	Comments
RW-1	--	--	--		Off	
RW-2	--	--	--		Off	
RW-3	10.63	11.69	1.06	P=7, D=10	14	
RW-4	10.10	10.25	0.15	P=1, D=10	13	
RW-5	--	--	--	Off	Off	
RW-6	8.36	9.19	0.83	C=3, D=15	13	
RW-7	7.77	7.81	0.04	C=4, D=15	14	
RW-8	8.99	9.11	0.12	P=1, D=10	11	
RW-9	8.37	9.41	1.04	P=7, D=15	Off	
MW-3	10.77	11.55	0.78		Off	
Depth to product in Convault			1.70 feet	Depth to water in Convault		1.88 feet
Approximate total volume recovered			202 gallons	Volume of Product in Convault 47 gallons		
PID Readings on vapor:			Inlet: 77 ppmv	Midpoint: 0 ppmv	Final: 0 ppmv	

Site Visit Date: 5/2/2008						
Recovery Well	Depth to Product (feet)	Depth to Water (feet)	Product Thickness (feet)	Cycles/Period and Duration	Vacuum (in. H ₂ O)	Comments
RW-1	--	--	--		Off	
RW-2	--	--	--		Off	
RW-3	10.64	11.66	1.02	P=7, D=10	14	
RW-4	10.09	10.23	0.14	P=1, D=10	13	
RW-5	--	--	--	Off	Off	
RW-6	8.33	9.17	0.84	C=3, D=15	13	
RW-7	7.75	7.81	0.06	C=4, D=15	14	
RW-8	8.89	9.16	0.27	P=1, D=10	11	
RW-9	8.34	9.41	1.07	P=7, D=15	Off	
MW-3	10.70	11.57	0.87		Off	
Depth to product in Convault			1.68 feet	Depth to water in Convault		1.87 feet
Approximate total volume recovered			207 gallons	Volume of Product in Convault 50 gallons		
PID Readings on vapor:			Inlet: 75 ppmv	Midpoint: 0 ppmv	Final: 0 ppmv	

**TABLE 3: Product Thickness Measurements and
Operations and Maintenance Activities - January through June 2008**

Port of Oakland
651 and 555 Maritime Street
Oakland, California

Site Visit Date: 5/9/2008						
Recovery Well	Depth to Product (feet)	Depth to Water (feet)	Product Thickness (feet)	Cycles/Period and Duration	Vacuum (in. H ₂ O)	Comments
RW-1	--	--	--		Off	
RW-2	--	--	--		Off	
RW-3	10.66	11.65	0.99	P=7, D=10	14	
RW-4	10.01	10.24	0.23	P=1, D=10	13	
RW-5	--	--	--	Off	Off	
RW-6	8.39	9.18	0.79	C=3, D=15	13	
RW-7	7.77	7.80	0.03	C=4, D=15	14	
RW-8	8.88	9.19	0.31	P=1, D=10	11	
RW-9	8.37	9.40	1.03	P=7, D=15	Off	
MW-3	10.77	11.57	0.80		Off	
Depth to product in Convault			1.68 feet	Depth to water in Convault		1.87 feet
Approximate total volume recovered			207 gallons	Volume of Product in Convault 50 gallons		
PID Readings on vapor:			Inlet: 75 ppmv	Midpoint: 0 ppmv	Final: 0 ppmv	

Site Visit Date: 5/16/2008						
Recovery Well	Depth to Product (feet)	Depth to Water (feet)	Product Thickness (feet)	Cycles/Period and Duration	Vacuum (in. H ₂ O)	Comments
RW-1	--	--	--		Off	
RW-2	--	--	--		Off	
RW-3	10.66	11.65	0.99	P=7, D=10	14	
RW-4	10.10	10.22	0.12	P=1, D=10	13	
RW-5	--	--	--	Off	Off	
RW-6	8.41	9.17	0.76	C=3, D=15	13	
RW-7	7.78	7.83	0.05	C=4, D=15	14	
RW-8	8.86	9.15	0.29	P=1, D=10	11	
RW-9	8.35	9.46	1.11	P=7, D=15	Off	
MW-3	10.79	11.61	0.82		Off	
Depth to product in Convault			1.65 feet	Depth to water in Convault		1.82 feet
Approximate total volume recovered			215 gallons	Volume of Product in Convault 44 gallons		
PID Readings on vapor:			Inlet: 77 ppmv	Midpoint: 0 ppmv	Final: 0 ppmv	

**TABLE 3: Product Thickness Measurements and
Operations and Maintenance Activities - January through June 2008**

Port of Oakland
651 and 555 Maritime Street
Oakland, California

Site Visit Date: 5/23/2008						
Recovery Well	Depth to Product (feet)	Depth to Water (feet)	Product Thickness (feet)	Cycles/Period and Duration	Vacuum (in. H ₂ O)	Comments
RW-1	--	--	--		Off	
RW-2	--	--	--		Off	
RW-3	10.64	11.62	0.98	P=7, D=10	14	
RW-4	10.13	10.19	0.06	P=1, D=10	13	
RW-5	--	--	--	Off	Off	
RW-6	8.39	9.20	0.81	C=3, D=15	13	
RW-7	7.81	7.87	0.06	C=4, D=15	14	
RW-8	8.89	9.18	0.29	P=1, D=10	11	
RW-9	8.33	9.43	1.10	P=7, D=15	Off	
MW-3	10.80	11.69	0.89		Off	
Depth to product in Convault			1.60 feet	Depth to water in Convault		1.81 feet
Approximate total volume recovered			228 gallons	Volume of Product in Convault 55 gallons		
PID Readings on vapor:			Inlet: 86 ppmv	Midpoint: 0 ppmv	Final: 0 ppmv	

Site Visit Date: 5/30/2008						
Recovery Well	Depth to Product (feet)	Depth to Water (feet)	Product Thickness (feet)	Cycles/Period and Duration	Vacuum (in. H ₂ O)	Comments
RW-1	--	--	--		Off	
RW-2	--	--	--		Off	
RW-3	10.96	11.00	0.04	P=7, D=10	10	
RW-4	10.67	11.19	0.52	P=2, D=10	12	
RW-5	--	--	--	Off	Off	
RW-6	8.71	10.29	1.58	C=2, D=15	11	
RW-7	8.10	9.33	1.23	P=1, D=10	11	
RW-8	9.30	10.55	1.25	P=1, D=10	12	
RW-9	9.89	11.17	1.28	P=5, D=10	10	
MW-3	10.85	11.77	0.92		Off	
Depth to product in Convault			2.30 feet	Depth to water in Convault		2.32 feet
Approximate total volume recovered			45 gallons	Convault emptied.		
PID Readings on vapor:			Inlet: 69 ppmv	Midpoint: 0.2 ppmv	Final: 0 ppmv	Flowrate: 46 CFM

**TABLE 3: Product Thickness Measurements and
Operations and Maintenance Activities - January through June 2008**

Port of Oakland
651 and 555 Maritime Street
Oakland, California

Site Visit Date: 6/6/2008						
Recovery Well	Depth to Product (feet)	Depth to Water (feet)	Product Thickness (feet)	Cycles/Period and Duration	Vacuum (in. H ₂ O)	Comments
RW-1	--	--	--		Off	
RW-2	--	--	--		Off	
RW-3	11.11	11.31	0.20	P=7, D=10	12	
RW-4	10.71	11.50	0.79	P=2, D=10	11	
RW-5	--	--	--	Off	Off	
RW-6	8.55	10.25	1.70	C=2, D=10	12	
RW-7	8.17	9.38	1.21	C=3, D=10	13	
RW-8	9.29	10.81	1.52	P=1, D=10	12	
RW-9	9.90	11.10	1.20	P=5, D=10	12	
MW-3	10.81	11.65	0.84		Off	
Depth to product in Convault			2.33 feet	Depth to water in Convault		2.35 feet
Approximate total volume recovered			37 gallons	Volume of Product in Convault 5 gallons		
PID Readings on vapor:			Inlet: 65 ppmv	Midpoint: 0.2 ppmv	Final: 0 ppmv	Flowrate: 44 CFM

Site Visit Date: 6/13/2008						
Recovery Well	Depth to Product (feet)	Depth to Water (feet)	Product Thickness (feet)	Cycles/Period and Duration	Vacuum (in. H ₂ O)	Comments
RW-1	--	--	--		Off	
RW-2	--	--	--		Off	
RW-3	10.95	10.99	0.04	P=7, D=10	12	
RW-4	10.69	11.15	0.46	P=2, D=10	12	
RW-5	--	--	--	Off	Off	
RW-6	8.58	10.22	1.64	C=2, D=10	11	
RW-7	8.15	9.35	1.20	P=1, D=10	11	
RW-8	9.27	10.50	1.23	P=1, D=10	12	
RW-9	9.89	11.15	1.26	P=5, D=10	12	
MW-3	--	--	--		Off	
Depth to product in Convault			2.34 feet	Depth to water in Convault		2.36 feet
Approximate total volume recovered			34 gallons	Volume of Product in Convault 5 gallons		
PID Readings on vapor:			Inlet: 66 ppmv	Midpoint: 0.2 ppmv	Final: 0 ppmv	Flowrate: 43 CFM

**TABLE 3: Product Thickness Measurements and
Operations and Maintenance Activities - January through June 2008**

Port of Oakland
651 and 555 Maritime Street
Oakland, California

Site Visit Date: 6/20/2008								
Recovery Well	Depth to Product (feet)	Depth to Water (feet)	Product Thickness (feet)	Cycles/Period and Duration	Vacuum (in. H ₂ O)	Comments		
RW-1	--	--	--		Off			
RW-2	--	--	--		Off			
RW-3	11.14	11.31	0.17	P=7, D=10	13			
RW-4	10.23	11.07	0.84	P=2, D=10	11			
RW-5	--	--	--	Off	Off	Truck parked on top. No one available to move it.		
RW-6	8.57	10.23	1.66	C=2, D=10	10			
RW-7	8.20	9.40	1.20	C=3, D=10	13			
RW-8	9.25	10.77	1.52	P=1, D=10	12			
RW-9	9.88	11.09	1.21	P=5, D=10	Off			
MW-3	--	--	--		Off	Street cleaning vehicle parked on top. No one available to move [it].		
Depth to product in Convault			2.40 feet	Depth to water in Convault		2.44 feet	Volume of Product in Convault	10 gallons
Approximate total volume recovered			18 gallons					
PID Readings on vapor:			Inlet: 63 ppmv	Midpoint: 0.4 ppmv	Final: 0 ppmv	Flowrate: 44 CFM		

Site Visit Date: 6/27/2008								
Recovery Well	Depth to Product (feet)	Depth to Water (feet)	Product Thickness (feet)	Cycles/Period and Duration	Vacuum (in. H ₂ O)	Comments		
RW-1	--	--	--		Off			
RW-2	--	--	--		Off			
RW-3	10.55	11.40	0.85	P=7, D=10	10			
RW-4	10.10	11.94	1.84	P=1, D=10	14			
RW-5	--	--	--	Off	Off	Truck is once again parked on top of location. No one available to remove truck.		
RW-6	8.40	9.56	1.16	C=3, D=15	10			
RW-7	7.85	8.00	0.15	C=4, D=15	14			
RW-8	9.08	9.20	0.12	P=1, D=10	11			
RW-9	8.40	9.55	1.15	P=7, D=15	10			
MW-3	10.80	11.62	0.82		Off			
Depth to product in Convault			2.42 feet	Depth to water in Convault		2.45 feet	Volume of Product in Convault	8 gallons
Approximate total volume recovered			13 gallons					
PID Readings on vapor:			Inlet: 62.5 ppmv	Midpoint: 0.2 ppmv	Final: 0 ppmv	Flowrate: 44 CFM		

**TABLE 3: Product Thickness Measurements and
Operations and Maintenance Activities - January through June 2008**

Port of Oakland
651 and 555 Maritime Street
Oakland, California

Notes:

See Figure 2 for recovery well locations.

D = Duration (length of time in minutes the skimmer will run upon activation)

P = Period (P=1 would indicate skimmer activated every day; P=4 would be skimmer activated every fourth day)

C = Cycles (C=2 would indicate skimmer activated twice per day; C=4 would indicate skimmer activated four times per day)

CFM = cubic feet per minute

gal . = gallons

H₂O = water

lbs = pounds

PID = Photo-ionization detector (hydrocarbons in gas measurement)

ppmv = parts per million by volume

-- = not measured.

Sheen = less than 0.01 foot thickness of product.

Product purging in is conducted using a peristaltic pump.

**TABLE 3: Product Thickness Measurements and
Operations and Maintenance Activities - July through December 2008**

Port of Oakland
651 Maritime Street
Oakland, California

Site Visit Date: 7/3/2008						
Recovery Well	Depth to Product (feet)	Depth to Water (feet)	Product Thickness (feet)	Cycles/Period and Duration	Vacuum (in. H ₂ O)	Comments
RW-1	--	--	--		Off	
RW-2	--	--	--		Off	
RW-3	10.90	10.95	0.05	P=7, D=10	10	
RW-4	10.70	11.22	0.52	P=2, D=10	11	
RW-5	--	--	--	--	--	Unable to check - truck parked on top.
RW-6	8.67	10.25	1.58	P=2, D=10	11	
RW-7	8.07	9.30	1.23	P=1, D=10	11	
RW-8	9.24	10.50	1.26	P=1, D=10	12	
RW-9	9.85	11.12	1.27	P=5, D=10	10	
MW-3	10.80	11.72	0.92		--	Removed approx 2 gallons.
Depth to product in Convault			2.35	feet	Depth to water in Convault 2.37 feet	
Approximate total volume recovered			32	gallons	Volume of Product in Convault 5 gallons	
PID Readings on vapor:			Inlet: 69	ppmv	Midpoint: 0.2	ppmv Final: 0 ppmv Flowrate: 45 CFM

Site Visit Date: 7/11/2008						
Recovery Well	Depth to Product (feet)	Depth to Water (feet)	Product Thickness (feet)	Cycles/Period and Duration	Vacuum (in. H ₂ O)	Comments
RW-1	--	--	--		Off	
RW-2	--	--	--		Off	
RW-3	10.87	10.91	0.04	P=7, D=10	12	
RW-4	10.65	11.10	0.45	P=2, D=10	12	
RW-5	--	--	--	--	--	Unable to check - truck parked on top.
RW-6	8.68	10.30	1.62	C=2, D=10	11	
RW-7	8.25	9.45	1.20	P=1, D=10	11	
RW-8	9.30	10.53	1.23	P=1, D=10	12	
RW-9	9.80	11.05	1.25	P=5, D=10	12	
MW-3	--	--	--		--	Street sweeper parked on top.
Depth to product in Convault			2.10	feet	Depth to water in Convault 2.15 feet	
Approximate total volume recovered			97	gallons	Volume of Product in Convault 13 gallons	
PID Readings on vapor:			Inlet: 65	ppmv	Midpoint: 0.3	ppmv Final: 0 ppmv

**TABLE 3: Product Thickness Measurements and
Operations and Maintenance Activities - July through December 2008**

Port of Oakland
651 Maritime Street
Oakland, California

Site Visit Date: 7/18/2008						
Recovery Well	Depth to Product (feet)	Depth to Water (feet)	Product Thickness (feet)	Cycles/Period and Duration	Vacuum (in. H ₂ O)	Comments
RW-1	--	--	--		Off	
RW-2	--	--	--		Off	
RW-3	10.90	11.17	0.27	P=7, D=10	12	
RW-4	10.60	10.85	0.25	P=2, D=10	11	
RW-5	--	--	--	--	--	Unable to check - truck parked on top.
RW-6	8.47	10.17	1.70	C=2, D=10	12	
RW-7	8.10	9.31	1.21	C=3, D=10	13	
RW-8	9.25	10.77	1.52	P=1, D=10	12	
RW-9	9.85	11.05	1.20	P=5, D=10	12	
MW-3	10.70	11.55	0.85		--	Removed approximately 1 gallon.
Depth to product in Convault			2.27	feet	Depth to water in Convault 2.30 feet	
Approximate total volume recovered			52	gallons	Volume of Product in Convault 8 gallons	
PID Readings on vapor:			Inlet: 66	ppmv	Midpoint: 0.2	ppmv Final: 0 ppmv Flowrate: 44 CFM

Site Visit Date: 7/25/2008						
Recovery Well	Depth to Product (feet)	Depth to Water (feet)	Product Thickness (feet)	Cycles/Period and Duration	Vacuum (in. H ₂ O)	Comments
RW-1	--	--	--		Off	
RW-2	--	--	--		Off	
RW-3	10.87	11.08	0.21	P=7, D=10	12	
RW-4	10.65	10.95	0.30	P=2, D=10	11	
RW-5	--	--	--	--	--	Unable to check - truck parked on top.
RW-6	8.50	10.20	1.70	C=2, D=10	12	
RW-7	8.30	9.51	1.21	C=3, D=10	13	
RW-8	9.30	10.80	1.50	P=1, D=10	12	
RW-9	9.90	11.10	1.20	P=5, D=10	12	
MW-3	--	--	--	--	--	Street sweeper parked on top.
Depth to product in Convault			2.30	feet	Depth to water in Convault 2.32 feet	
Approximate total volume recovered			45	gallons	Volume of Product in Convault 5 gallons	
PID Readings on vapor:			Inlet: 68	ppmv	Midpoint: 0.4	ppmv Final: 0 ppmv Flowrate: 44 CFM

**TABLE 3: Product Thickness Measurements and
Operations and Maintenance Activities - July through December 2008**

Port of Oakland
651 Maritime Street
Oakland, California

Site Visit Date: 8/1/2008						
Recovery Well	Depth to Product (feet)	Depth to Water (feet)	Product Thickness (feet)	Cycles/Period and Duration	Vacuum (in. H ₂ O)	Comments
RW-1	--	--	--		Off	
RW-2	--	--	--		Off	
RW-3	10.75	11.05	0.30	P=7, D=10	10	
RW-4	10.80	11.30	0.50	P=2, D=10	12	
RW-5	9.05	9.30	0.25	--	--	
RW-6	8.75	10.30	1.55	C=2, D=10	11	
RW-7	8.17	9.40	1.23	C=3, D=10	13	
RW-8	9.35	10.85	1.50	P=1, D=10	12	
RW-9	10.05	11.25	1.20	P=5, D=10	12	
MW-3	11.05	11.90	0.85	--	--	
Depth to product in Convault			2.50	feet	Depth to water in Convault 2.55 feet	
Approximate total volume recovered			--	gallons	Volume of Product in Convault -- gallons	
PID Readings on vapor:			Inlet: 72	ppmv	Midpoint: 0.3	ppmv
					Final: 0	ppmv
					Flowrate: 45	CFM

Site Visit Date: 8/8/2008						
Recovery Well	Depth to Product (feet)	Depth to Water (feet)	Product Thickness (feet)	Cycles/Period and Duration	Vacuum (in. H ₂ O)	Comments
RW-1	--	--	--		Off	
RW-2	--	--	--		Off	
RW-3	10.60	10.90	0.30	P=7, D=10	10	
RW-4	10.75	11.25	0.50	P=2, D=10	12	
RW-5	8.90	9.20	0.30	--	--	
RW-6	8.70	10.25	1.55	C=2, D=10	11	
RW-7	8.11	9.32	1.21	C=3, D=10	13	
RW-8	9.22	10.73	1.51	P=7, D=10	12	
RW-9	9.90	11.10	1.20	P=5, D=10	12	
MW-3	10.95	11.80	0.85	--	--	
Depth to product in Convault			2.20	feet	Depth to water in Convault 2.50 feet	
Approximate total volume recovered			71	gallons	Volume of Product in Convault 71 gallons	
PID Readings on vapor:			Inlet: 68	ppmv	Midpoint: 0.2	ppmv
					Final: 0	ppmv
					Flowrate: 44	CFM

**TABLE 3: Product Thickness Measurements and
Operations and Maintenance Activities - July through December 2008**

Port of Oakland
651 Maritime Street
Oakland, California

Site Visit Date: 8/15/2008						
Recovery Well	Depth to Product (feet)	Depth to Water (feet)	Product Thickness (feet)	Cycles/Period and Duration	Vacuum (in. H ₂ O)	Comments
RW-1	--	--	--		Off	
RW-2	--	--	--		Off	
RW-3	10.20	10.50	0.30	P=7, D=10	10	
RW-4	10.35	10.85	0.50	P=2, D=10	12	
RW-5	8.50	8.80	0.30	--	--	
RW-6	8.30	9.85	1.55	C=2, D=10	11	
RW-7	7.70	8.92	1.22	C=3, D=10	13	
RW-8	8.82	10.33	1.51	P=7, D=10	12	
RW-9	9.50	10.70	1.20	P=5, D=10	12	
MW-3	--	--	--	--	--	Street sweeper parked on top.
Depth to product in Convault			2.15	feet	Depth to water in Convault 2.45 feet	
Approximate total volume recovered			84	gallons	Volume of Product in Convault 78 gallons	
PID Readings on vapor:			Inlet: 74	ppmv	Midpoint: 0.4	ppmv Final: 0 ppmv Flowrate: 45 CFM

Site Visit Date: 8/22/2008						
Recovery Well	Depth to Product (feet)	Depth to Water (feet)	Product Thickness (feet)	Cycles/Period and Duration	Vacuum (in. H ₂ O)	Comments
RW-1	--	--	--		Off	
RW-2	--	--	--		Off	
RW-3	10.50	10.80	0.30	P=7, D=10	10	
RW-4	10.60	11.20	0.60	P=2, D=10	12	
RW-5	--	--	--	--	--	Unable to check - truck parked on top.
RW-6	8.65	10.20	1.55	C=2, D=10	11	
RW-7	8.15	9.34	1.19	C=3, D=10	13	
RW-8	9.25	10.75	1.50	P=7, D=10	12	
RW-9	9.95	11.15	1.20	P=5, D=10	12	
MW-3	--	--	--	--	--	Street sweeper parked on top.
Depth to product in Convault			2.17	feet	Depth to water in Convault 2.51 feet	
Approximate total volume recovered			79	gallons	Volume of Product in Convault 79 gallons	
PID Readings on vapor:			Inlet: 71	ppmv	Midpoint: 0.4	ppmv Final: 0 ppmv Flowrate: 44 CFM

**TABLE 3: Product Thickness Measurements and
Operations and Maintenance Activities - July through December 2008**

Port of Oakland
651 Maritime Street
Oakland, California

Site Visit Date: 8/29/2008						
Recovery Well	Depth to Product (feet)	Depth to Water (feet)	Product Thickness (feet)	Cycles/Period and Duration	Vacuum (in. H ₂ O)	Comments
RW-1	--	--	--		Off	
RW-2	--	--	--		Off	
RW-3	10.35	10.65	0.30	P=7, D=10	9	
RW-4	10.50	11.10	0.60	P=2, D=10	10	
RW-5	--	--	--	--	--	Truck parked on top.
RW-6	8.57	10.12	1.55	C=2, D=10	10	
RW-7	8.10	9.29	1.19	C=3, D=10	12	
RW-8	9.20	10.70	1.50	P=7, D=10	12	
RW-9	9.89	11.09	1.20	P=5, D=10	11	
MW-3	--	--	--	--	--	Street sweeper parked on top.
Depth to product in Convault			2.15	feet	Depth to water in Convault 2.50 feet	
Approximate total volume recovered			84	gallons	Volume of Product in Convault 84 gallons	
PID Readings on vapor:			Inlet: 73	ppmv	Midpoint: 0.4	ppmv
					Final: 0	ppmv
					Flowrate: 45	CFM

Site Visit Date: 9/5/2008						
Recovery Well	Depth to Product (feet)	Depth to Water (feet)	Product Thickness (feet)	Cycles/Period and Duration	Vacuum (in. H ₂ O)	Comments
RW-1	--	--	--		Off	
RW-2	--	--	--		Off	
RW-3	10.30	10.60	0.30	P=7, D=10	9	
RW-4	10.45	11.00	0.55	P=2, D=10	10	
RW-5	--	--	--	--	--	Truck parked on top.
RW-6	8.50	10.05	1.55	C=2, D=10	10	
RW-7	8.05	9.24	1.19	C=3, D=10	12	
RW-8	9.10	10.60	1.50	P=7, D=10	12	
RW-9	9.80	11.00	1.20	P=5, D=10	11	
MW-3	--	--	--	--	--	Street sweeper parked on top.
Depth to product in Convault			2.13	feet	Depth to water in Convault 2.47 feet	
Approximate total volume recovered			89	gallons	Volume of Product in Convault 89 gallons	
PID Readings on vapor:			Inlet: 70	ppmv	Midpoint: 0.4	ppmv
					Final: 0	ppmv
					Flowrate: 44	CFM

**TABLE 3: Product Thickness Measurements and
Operations and Maintenance Activities - July through December 2008**

Port of Oakland
651 Maritime Street
Oakland, California

Site Visit Date: 9/12/2008						
Recovery Well	Depth to Product (feet)	Depth to Water (feet)	Product Thickness (feet)	Cycles/Period and Duration	Vacuum (in. H ₂ O)	Comments
RW-1	--	--	--		Off	
RW-2	--	--	--		Off	
RW-3	10.35	10.65	0.30	P=7, D=10	9	
RW-4	10.47	11.05	0.58	P=2, D=10	10	
RW-5	8.80	9.00	0.20	--	--	
RW-6	8.55	10.10	1.55	C=2, D=10	10	
RW-7	8.10	9.29	1.19	C=3, D=10	12	
RW-8	9.15	10.65	1.50	P=7, D=10	12	
RW-9	9.85	11.05	1.20	P=5, D=10	11	
MW-3	10.90	11.75	0.85	--	--	
Depth to product in Convault			2.17	feet	Depth to water in Convault 2.45 feet	
Approximate total volume recovered			79	gallons	Volume of Product in Convault 73 gallons	
PID Readings on vapor:			Inlet: 71	ppmv	Midpoint: 0.4	ppmv
					Final: 0	ppmv
					Flowrate: 44	CFM

Site Visit Date: 9/19/2008						
Recovery Well	Depth to Product (feet)	Depth to Water (feet)	Product Thickness (feet)	Cycles/Period and Duration	Vacuum (in. H ₂ O)	Comments
RW-1	--	--	--		Off	
RW-2	--	--	--		Off	
RW-3	10.30	10.60	0.30	P=7, D=10	9	
RW-4	10.45	11.00	0.55	P=2, D=10	10	
RW-5	8.85	9.10	0.25	--	--	
RW-6	8.50	10.05	1.55	C=2, D=10	10	
RW-7	8.08	9.27	1.19	C=3, D=10	12	
RW-8	9.10	10.60	1.50	P=7, D=10	12	
RW-9	9.80	11.00	1.20	P=5, D=10	11	
MW-3	10.85	11.70	0.85	--	--	
Depth to product in Convault			2.19	feet	Depth to water in Convault 2.46 feet	
Approximate total volume recovered			73	gallons	Volume of Product in Convault 71 gallons	
PID Readings on vapor:			Inlet: 70	ppmv	Midpoint: 0.3	ppmv
					Final: 0	ppmv
					Flowrate: 44	CFM

**TABLE 3: Product Thickness Measurements and
Operations and Maintenance Activities - July through December 2008**

Port of Oakland
651 Maritime Street
Oakland, California

Site Visit Date: 9/26/2008									
Recovery Well	Depth to Product (feet)	Depth to Water (feet)	Product Thickness (feet)	Cycles/Period and Duration	Vacuum (in. H ₂ O)	Comments			
RW-1	--	--	--		Off				
RW-2	--	--	--		Off				
RW-3	10.50	11.07	0.57	P=7, D=10	9				
RW-4	10.40	11.05	0.65	P=7, D=10	10				
RW-5	8.90	9.15	0.25	--	--				
RW-6	8.60	10.15	1.55	C=2, D=10	10				
RW-7	8.10	9.30	1.20	C=3, D=10	12				
RW-8	9.20	10.70	1.50	P=5, D=10	12				
RW-9	9.90	11.10	1.20	P=5, D=10	11				
MW-3	10.92	11.83	0.91	--	--				
Depth to product in Convault			2.10	feet	Depth to water in Convault	2.39 feet	Volume of Product in Convault	76	gallons
Approximate total volume recovered			97	gallons					
PID Readings on vapor:			Inlet: 72	ppmv	Midpoint: 0.4	ppmv	Final: 0	ppmv	Flowrate: 45 CFM

Site Visit Date: 10/3/2008									
Recovery Well	Depth to Product (feet)	Depth to Water (feet)	Product Thickness (feet)	Cycles/Period and Duration	Vacuum (in. H ₂ O)	Comments			
RW-1	--	--	--		Off				
RW-2	--	--	--		Off				
RW-3	10.55	11.15	0.60	P=7, D=10	9				
RW-4	10.50	11.20	0.70	P=7, D=10	10				
RW-5	8.95	9.20	0.25	--	--				
RW-6	8.65	10.20	1.55	C=2, D=10	10				
RW-7	8.20	9.40	1.20	C=3, D=10	12				
RW-8	9.25	10.75	1.50	P=7, D=10	12				
RW-9	9.85	11.05	1.20	P=5, D=10	11				
MW-3	10.95	11.85	0.90	--	--				
Depth to product in Convault			2.07	feet	Depth to water in Convault	2.39 feet	Volume of Product in Convault	84	gallons
Approximate total volume recovered			105	gallons					
PID Readings on vapor:			Inlet: 72	ppmv	Midpoint: 0.4	ppmv	Final: 0	ppmv	Flowrate: 45 CFM

**TABLE 3: Product Thickness Measurements and
Operations and Maintenance Activities - July through December 2008**

Port of Oakland
651 Maritime Street
Oakland, California

Site Visit Date: 10/10/2008						
Recovery Well	Depth to Product (feet)	Depth to Water (feet)	Product Thickness (feet)	Cycles/Period and Duration	Vacuum (in. H ₂ O)	Comments
RW-1	--	--	--		Off	
RW-2	--	--	--		Off	
RW-3	10.40	11.00	0.60	P=7, D=10	9	
RW-4	10.45	11.15	0.70	P=7, D=10	10	
RW-5	8.90	9.10	0.20	--	--	
RW-6	8.60	10.10	1.50	C=2, D=10	10	
RW-7	8.10	9.30	1.20	C=3, D=10	12	
RW-8	9.10	10.50	1.40	P=5, D=10	11	
RW-9	9.80	11.00	1.20	P=5, D=10	11	
MW-3	10.90	11.80	0.90	--	--	
Depth to product in Convault -- feet Depth to water in Convault -- feet Volume of Product in Convault -- gallons Approximate total volume recovered -- gallons PID Readings on vapor: Inlet: -- ppmv Midpoint: -- ppmv Final: -- ppmv Flowrate: -- CFM						

Site Visit Date: 10/17/2008						
Recovery Well	Depth to Product (feet)	Depth to Water (feet)	Product Thickness (feet)	Cycles/Period and Duration	Vacuum (in. H ₂ O)	Comments
RW-1	--	--	--		Off	
RW-2	--	--	--		Off	
RW-3	10.60	11.20	0.60	P=7, D=10	9	
RW-4	10.55	11.25	0.70	P=7, D=10	10	
RW-5	9.00	9.30	0.30	--	--	
RW-6	8.70	10.25	1.55	C=2, D=10	10	
RW-7	8.25	9.45	1.20	C=3, D=10	12	
RW-8	9.30	10.80	1.50	P=7, D=10	11	
RW-9	9.90	10.10	0.20	P=5, D=10	11	
MW-3	11.00	11.90	0.90	--	--	
Depth to product in Convault -- feet Depth to water in Convault -- feet Volume of Product in Convault -- gallons Approximate total volume recovered -- gallons PID Readings on vapor: Inlet: -- ppmv Midpoint: -- ppmv Final: -- ppmv Flowrate: -- CFM						

**TABLE 3: Product Thickness Measurements and
Operations and Maintenance Activities - July through December 2008**

Port of Oakland
651 Maritime Street
Oakland, California

Site Visit Date: 10/24/2008																
Recovery Well	Depth to Product (feet)	Depth to Water (feet)	Product Thickness (feet)	Cycles/Period and Duration	Vacuum (in. H ₂ O)	Comments										
RW-1	--	--	--		Off											
RW-2	--	--	--		Off											
RW-3	10.30	11.00	0.70	P=7, D=10	9											
RW-4	10.55	11.25	0.70	P=7, D=10	10											
RW-5	--	--	--	--	--	Truck parked on top.										
RW-6	8.50	10.05	1.55	C=2, D=10	10											
RW-7	8.05	9.25	1.20	C=3, D=10	12											
RW-8	9.10	10.60	1.50	P=7, D=10	11											
RW-9	9.70	10.90	1.20	P=5, D=10	11											
MW-3	--	--	--	--	--	Street cleaner parked on top.										
Depth to product in Convault			--	feet	Depth to water in Convault		--	feet	Volume of Product in Convault		--	gallons				
Approximate total volume recovered			--	gallons	Midpoint:		--	ppmv	Final:		--	ppmv	Flowrate:	--	CFM	
PID Readings on vapor:			Inlet:	--	ppmv	Midpoint:		--	ppmv	Final:		--	ppmv	Flowrate:	--	CFM

Site Visit Date: 10/31/2008																
Recovery Well	Depth to Product (feet)	Depth to Water (feet)	Product Thickness (feet)	Cycles/Period and Duration	Vacuum (in. H ₂ O)	Comments										
RW-1	--	--	--		Off											
RW-2	--	--	--		Off											
RW-3	11.10	11.40	0.30	P=7, D=10	9											
RW-4	11.25	11.57	0.32	P=7, D=10	10											
RW-5	--	--	--	--	--	Truck parked on top.										
RW-6	9.00	10.10	1.10	C=2, D=10	10											
RW-7	8.55	9.70	1.15	C=3, D=10	12											
RW-8	9.10	10.20	1.10	P=7, D=10	11											
RW-9	10.10	11.00	0.90	P=5, D=10	11											
MW-3	--	--	--	--	--	Street sweeper paprked on top.										
Depth to product in Convault			2.30	feet	Depth to water in Convault		2.50	feet	Volume of Product in Convault		45	gallons				
Approximate total volume recovered			45	gallons	Midpoint:		0.3	ppmv	Final:		0	ppmv	Flowrate:	44	CFM	
PID Readings on vapor:			Inlet:	69.5	ppmv	Midpoint:		0.3	ppmv	Final:		0	ppmv	Flowrate:	44	CFM

**TABLE 3: Product Thickness Measurements and
Operations and Maintenance Activities - July through December 2008**

Port of Oakland
651 Maritime Street
Oakland, California

Site Visit Date: 11/7/2008						
Recovery Well	Depth to Product (feet)	Depth to Water (feet)	Product Thickness (feet)	Cycles/Period and Duration	Vacuum (in. H ₂ O)	Comments
RW-1	--	--	--		Off	
RW-2	--	--	--		Off	
RW-3	10.22	10.90	0.68	P=7, D=10	9	
RW-4	10.50	11.20	0.70	P=7, D=10	10	
RW-5	--	--	--	--	--	Truck parked on top.
RW-6	9.00	10.50	1.50	P=7, D=10	10	
RW-7	8.45	9.20	0.75	C=3, D=10	12	
RW-8	9.30	10.80	1.50	P=7, D=10	11	
RW-9	9.90	11.10	1.20	P=5, D=10	11	
MW-3	--	--	--	--	--	Street sweeper parked on top.
Depth to product in Convault			2.40	feet	Depth to water in Convault 2.50 feet	
Approximate total volume recovered			18	gallons	Volume of Product in Convault 18 gallons	
PID Readings on vapor:			Inlet: 70	ppmv	Midpoint: 0.3	ppmv
					Final: 0	ppmv
					Flowrate: 45	CFM

Site Visit Date: 11/14/2008						
Recovery Well	Depth to Product (feet)	Depth to Water (feet)	Product Thickness (feet)	Cycles/Period and Duration	Vacuum (in. H ₂ O)	Comments
RW-1	--	--	--		Off	
RW-2	--	--	--		Off	
RW-3	10.05	10.55	0.50	P=7, D=10	9	
RW-4	10.10	11.00	0.90	P=7, D=10	10	
RW-5	9.25	9.50	0.25	--	--	
RW-6	8.45	9.55	1.10	C=2, D=10	10	
RW-7	9.10	9.40	0.30	C=3, D=10	12	
RW-8	9.20	10.70	1.50	P=7, D=10	11	
RW-9	9.75	11.00	1.25	P=5, D=10	11	
MW-3	10.75	11.30	0.55	--	--	
Depth to product in Convault			2.25	feet	Depth to water in Convault 2.45 feet	
Approximate total volume recovered			58	gallons	Volume of Product in Convault 52 gallons	
PID Readings on vapor:			Inlet: 68	ppmv	Midpoint: 0.3	ppmv
					Final: 0	ppmv
					Flowrate: 44	CFM

**TABLE 3: Product Thickness Measurements and
Operations and Maintenance Activities - July through December 2008**

Port of Oakland
651 Maritime Street
Oakland, California

Site Visit Date: 11/21/2008						
Recovery Well	Depth to Product (feet)	Depth to Water (feet)	Product Thickness (feet)	Cycles/Period and Duration	Vacuum (in. H ₂ O)	Comments
RW-1	--	--	--		Off	
RW-2	--	--	--		Off	
RW-3	10.55	11.40	0.85	P=7, D=10	9	
RW-4	10.40	11.10	0.70	P=7, D=10	10	
RW-5	9.30	9.55	0.25	--	--	
RW-6	9.10	9.50	0.40	C=2, D=10	10	
RW-7	8.50	9.75	1.25	C=3, D=10	12	
RW-8	9.65	11.00	1.35	P=7, D=10	11	
RW-9	10.25	11.50	1.25	P=5, D=10	11	
MW-3	11.30	12.45	1.15	--	--	
Depth to product in Convault			2.25	feet	Depth to water in Convault 2.55 feet	
Approximate total volume recovered			58	gallons	Volume of Product in Convault 58 gallons	
PID Readings on vapor:			Inlet: 66	ppmv	Midpoint: 0.3	ppmv
					Final: 0	ppmv
					Flowrate: 44	CFM

Site Visit Date: 11/28/2008						
Recovery Well	Depth to Product (feet)	Depth to Water (feet)	Product Thickness (feet)	Cycles/Period and Duration	Vacuum (in. H ₂ O)	Comments
RW-1	--	--	--		Off	
RW-2	--	--	--		Off	
RW-3	11.20	12.00	0.80	P=7, D=10	9	
RW-4	11.05	11.70	0.65	P=7, D=10	10	
RW-5	10.65	11.20	0.55	--	--	
RW-6	10.10	11.00	0.90	C=2, D=10	10	
RW-7	10.25	11.30	1.05	C=3, D=10	12	
RW-8	10.15	10.45	0.30	P=7, D=10	11	
RW-9	9.75	10.50	0.75	P=5, D=10	11	
MW-3	10.65	11.30	0.65	--	--	
Depth to product in Convault			2.25	feet	Depth to water in Convault 2.40 feet	
Approximate total volume recovered			58	gallons	Volume of Product in Convault 39 gallons	
PID Readings on vapor:			Inlet: 72	ppmv	Midpoint: 0.3	ppmv
					Final: 0	ppmv
					Flowrate: 45	CFM

**TABLE 3: Product Thickness Measurements and
Operations and Maintenance Activities - July through December 2008**

Port of Oakland
651 Maritime Street
Oakland, California

Site Visit Date: 12/5/2008										
Recovery Well	Depth to Product (feet)	Depth to Water (feet)	Product Thickness (feet)	Cycles/Period and Duration	Vacuum (in. H ₂ O)	Comments				
RW-1	--	--	--		Off					
RW-2	--	--	--		Off					
RW-3	10.91	11.06	0.15	P=7, D=10	9					
RW-4	10.15	10.46	0.31	P=1, D=10	10					
RW-5	8.65	8.76	0.11	--	--					
RW-6	9.25	9.39	0.14	C=2, D=10	10					
RW-7	8.40	8.70	0.30	C=3, D=10	12					
RW-8	9.90	10.10	0.20	P=1, D=10	11					
RW-9	10.70	10.80	0.10	P=5, D=10	11					
MW-3	10.75	11.80	1.05	--	--					
Depth to product in Convault			2.20	feet	Depth to water in Convault	2.35 feet	Volume of Product in Convault	39	gallons	
Approximate total volume recovered			71	gallons						
PID Readings on vapor:			Inlet: 70	ppmv	Midpoint: 0.3	ppmv	Final: 0	ppmv	Flowrate: 44	CFM

Site Visit Date: 12/12/2008										
Recovery Well	Depth to Product (feet)	Depth to Water (feet)	Product Thickness (feet)	Cycles/Period and Duration	Vacuum (in. H ₂ O)	Comments				
RW-1	--	--	--		Off					
RW-2	--	--	--		Off					
RW-3	11.29	11.45	0.16	P=7, D=10	9					
RW-4	10.30	10.60	0.30	P=1, D=10	10					
RW-5	8.90	9.10	0.20	--	--					
RW-6	9.25	9.40	0.15	C=2, D=10	10					
RW-7	8.70	8.85	0.15	C=3, D=10	12					
RW-8	9.75	10.20	0.45	P=1, D=10	11					
RW-9	10.60	10.80	0.20	P=5, D=10	11					
MW-3	11.00	12.20	1.20	--	--					
Depth to product in Convault			2.10	feet	Depth to water in Convault	2.30 feet	Volume of Product in Convault	52	gallons	
Approximate total volume recovered			97	gallons						
PID Readings on vapor:			Inlet: 69	ppmv	Midpoint: 0.3	ppmv	Final: 0	ppmv	Flowrate: 45	CFM

**TABLE 3: Product Thickness Measurements and
Operations and Maintenance Activities - July through December 2008**

Port of Oakland
651 Maritime Street
Oakland, California

Site Visit Date: 12/19/2008						
Recovery Well	Depth to Product (feet)	Depth to Water (feet)	Product Thickness (feet)	Cycles/Period and Duration	Vacuum (in. H ₂ O)	Comments
RW-1	--	--	--		Off	
RW-2	--	--	--		Off	
RW-3	10.90	11.20	0.30	P=7, D=10	9	
RW-4	10.10	10.20	0.10	P=1, D=10	10	
RW-5	8.60	8.90	0.30	--	--	
RW-6	9.20	9.40	0.20	C=2, D=10	10	
RW-7	8.50	8.70	0.20	C=3, D=10	12	
RW-8	9.65	10.00	0.35	P=1, D=10	11	
RW-9	10.50	10.85	0.35	P=5, D=10	11	
MW-3	10.70	11.65	0.95	--	--	
Depth to product in Convault			2.12	feet	Depth to water in Convault 2.27 feet	
Approximate total volume recovered			92	gallons	Volume of Product in Convault 39 gallons	
PID Readings on vapor:			Inlet: 72	ppmv	Midpoint: 0.4	ppmv
					Final: 0	ppmv
					Flowrate: 45	CFM

Site Visit Date: 12/26/2008						
Recovery Well	Depth to Product (feet)	Depth to Water (feet)	Product Thickness (feet)	Cycles/Period and Duration	Vacuum (in. H ₂ O)	Comments
RW-1	--	--	--		Off	
RW-2	--	--	--		Off	
RW-3	10.90	11.20	0.30	P=7, D=10	9	
RW-4	10.10	10.15	0.05	P=1, D=10	10	
RW-5	8.60	8.77	0.17	--	--	
RW-6	9.25	9.32	0.07	C=2, D=10	10	
RW-7	8.50	9.00	0.50	C=3, D=10	12	
RW-8	9.60	9.83	0.23	P=1, D=10	11	
RW-9	10.35	11.15	0.80	P=5, D=10	11	
MW-3	10.80	11.70	0.90	--	--	
Depth to product in Convault			2.10	feet	Depth to water in Convault 2.20 feet	
Approximate total volume recovered			97	gallons	Volume of Product in Convault 26 gallons	
PID Readings on vapor:			Inlet: 70	ppmv	Midpoint: 0.3	ppmv
					Final: 0	ppmv
					Flowrate: 44	CFM

**TABLE 3: Product Thickness Measurements and
Operations and Maintenance Activities - July through December 2008**

Port of Oakland
651 Maritime Street
Oakland, California

Notes:

See Figure 2 for recovery well locations.

D = Duration (length of time in minutes the skimmer will run upon activation)

P = Period (P=1 would indicate skimmer activated every day; P=4 would be skimmer activated every fourth day)

C = Cycles (C=2 would indicate skimmer activated twice per day; C=4 would indicate skimmer activated four times per day)

CFM = cubic feet per minute

gal . = gallons

H₂O = water

lbs = pounds

PID = Photo-ionization detector (hydrocarbons in gas measurement)

ppmv = parts per million by volume

-- = not measured.

Sheen = less than 0.01 foot thickness of product.

Product purging in is conducted using a peristaltic pump.

TABLE 3. Free Product Removal System Operation and Maintenance Records Summary
January 8 through June 30, 2009
Port of Oakland's Harbor Facilities Complex Site
555 - 651 Maritime Street, Oakland, California

Site Visit Date: 01/08/09										
Recovery Well	Depth to Product (ft)	Depth to Water (ft)	Product Thickness (ft)	Depth of Pump (ft)	Vacuum (in/H ₂ O)	Cycles/Period and Duration	Last Run	Start Time	Total Time (hr:min)	Comments
RW-1	--	--	--		Off	Off		3/29/07 14:01	0:00	
RW-2	NP	9.38	0.00					NA		
RW-3	11.17	11.67	0.50	11.0	Off	P=7;D=10	1/2/09 18:01	8/3/07 18:01	24:20	Purged 3 gal. Replaced filter on skimmer.
RW-4	10.24	10.98	0.74	10.0	Off	P=1;D=10	1/7/09 18:01	7/15/07 18:01	90:30	Purged 1 gallon.
RW-5	8.60	10.24	1.64		Off	Off		8/24/07 18:07	0:00	Purged 2 gal.
RW-6	9.12	10.21	1.09	9.0	Off	C=3;D=15	1/8/09 2:01	9/14/07 18:01	326:10	Purged 3.5 gal. Lowered pump.
RW-7	8.25	11.07	2.82	8.0	Off	C=4;D=15	1/8/09 6:30	9/14/07 18:30	426:90	Purged 5 gal. Lowered pump.
RW-8	9.41	11.94	2.53	9.0	Off	P=1;D=10	1/7/09 18:01	8/10/07 18:01	102:10	Purged 4 gal.
RW-9	9.62	16.40	6.78	11.0	Off	P=7;D=15	1/2/09 18:01	11/28/07 18:01	16:30	Purged 12 gal. Lowered pump.
MW-3	10.98	12.38	1.40		NA	NA	NA	NA	NA	Purge 20 gal of product.
Depth to product in Convault				2.17	ft					
Depth to interface in Convault				2.41	ft					
Approximate total liquid volume recovered				79	gal					
Approximate product volume recovered				63	gal					

Site Visit Date: 01/16/09										
Recovery Well	Depth to Product (ft)	Depth to Water (ft)	Product Thickness (ft)	Depth of Pump (ft)	Vacuum (in/H ₂ O)	Cycles/Period and Duration	Last Run	Start Time	Total Time (hr:min)	Comments
RW-1	--	--	--		Off	Off		3/29/07 14:01	0:00	
RW-2	NP	9.79	0.00		Off	Off		NA		
RW-3	11.38	11.43	0.05	11.0	Off	P=7;D=10		8/3/07 18:01	24:20	
RW-4	10.41	11.55	1.14	10.0	Off	P=1;D=10		7/15/07 18:01	90:50	
RW-5	8.84	9.03	0.19		Off	Off		8/24/07 18:07	0:00	
RW-6	9.09	10.96	1.87	9.0	Off	C=3;D=15		9/14/07 18:01	362:25	
RW-7	8.31	10.99	2.68	8.0	Off	C=4;D=15		9/14/07 18:30	426:24	
RW-8	9.55	11.55	2.00	9.0	Off	P=1;D=10		8/10/07 18:01	102:10	
RW-9	10.15	11.54	1.39	12.0	Off	P=7;D=15		11/28/07 18:01	16:30	
MW-3	11.06	12.78	1.72		NA	NA		NA		
Depth to product in Convault				1.90	ft					
Depth to interface in Convault				2.32	ft					
Approximate total liquid volume recovered				149	gal					
Approximate product volume recovered				110	gal					

**TABLE 3. Free Product Removal System Operation and Maintenance Records Summary
January 8 through June 30, 2009
Port of Oakland's Harbor Facilities Complex Site
555 - 651 Maritime Street, Oakland, California**

Site Visit Date: 01/20/09										
Recovery Well	Depth to Product (ft)	Depth to Water (ft)	Product Thickness (ft)	Depth of Pump (ft)	Vacuum (in/H ₂ O)	Cycles/Period and Duration	Last Run	Start Time	Total Time (hr:min)	Comments
RW-1	--	--	--		Off	Off		3/29/07 14:01		
RW-2	--	--	--		Off	Off		NA		
RW-3	--	--	--		Off	P=14;D=10		1/21/09 18:00		
RW-4	--	--	--		Off	P=7;D=15		1/21/09 18:00		Steam cleaned skimmer and replaced filter.
RW-5	--	--	--		Off	Off		8/24/07 18:07		
RW-6	--	--	--		Off	P=7;D=15		1/21/09 18:00		
RW-7	--	--	--		Off	P=7;D=20		1/21/09 18:00		
RW-8	--	--	--		Off	P=7;D=15		1/21/09 18:00		
RW-9	--	--	--		Off	P=7;D=15		1/21/09 18:00		
MW-3	--	--	--		NA	NA		NA		
Depth to product in Convault				NM	ft					
Depth to interface in Convault				NM	ft					
Approximate total liquid volume recovered				NM	gal					
Approximate product volume recovered				NM	gal					

Site Visit Date: 01/26/09										
Recovery Well	Depth to Product (ft)	Depth to Water (ft)	Product Thickness (ft)	Depth of Pump (ft)	Vacuum (in/H ₂ O)	Cycles/Period and Duration	Last Run	Start Time	Total Time (hr:min)	Comments
RW-1	--	--	--		Off	Off		3/29/07 14:01		
RW-2	--	--	--		Off	Off		NA		
RW-3	11.18	11.31	0.13	11.0	Off	P=14;D=10	1/2/09 18:01	1/21/09 18:00	24:30	
RW-4	10.30	10.92	0.62	10.0	Off	P=7;D=15	1/7/09 18:01	1/21/09 18:00	90:45	
RW-5	--	--	--		Off	Off		8/24/07 18:07		
RW-6	8.93	10.48	1.55	9.0	Off	P=7;D=15	1/8/09 2:01	1/21/09 18:00	362:40	
RW-7	8.27	10.80	2.53	8.0	Off	P=7;D=20	1/8/09 6:30	1/21/09 18:00	426:44	
RW-8	9.34	10.62	1.28	9.0	Off	P=7;D=15	1/7/09 18:01	1/21/09 18:00	102:25	
RW-9	9.98	11.01	1.03	12.0	Off	P=7;D=15	1/2/09 18:01	1/21/09 18:00	16:45	
MW-3	11.04	12.94	1.90		NA	NA		NA		Removed 5 gal of product.
Depth to product in Convault				1.88	ft					
Depth to interface in Convault				2.48	ft					
Approximate total liquid volume recovered				154	gal					
Approximate product volume recovered				157	gal					

TABLE 3. Free Product Removal System Operation and Maintenance Records Summary
January 8 through June 30, 2009
Port of Oakland's Harbor Facilities Complex Site
555 - 651 Maritime Street, Oakland, California

Site Visit Date: 02/04/09										
Recovery Well	Depth to Product (ft)	Depth to Water (ft)	Product Thickness (ft)	Depth of Pump (ft)	Vacuum (in/H ₂ O)	Cycles/Period and Duration	Last Run	Start Time	Total Time (hr:min)	Comments
RW-1	--	--	--		Off	Off		3/29/07 14:01		
RW-2	--	--	--		Off	Off		NA		
RW-3	11.20	11.32	0.12	11.0	Off	P=14;D=10	1/21/09 18:00	1/21/09 18:00	24:30	
RW-4	10.29	10.83	0.54	10.0	Off	P=7;D=15	1/28/09 18:00	1/21/09 18:00	91:00	
RW-5	--	--	--		Off	Off		8/24/07 18:07		
RW-6	9.00	10.98	1.98	9.0	Off	P=1;D=10	1/28/09 18:00	1/21/09 18:00	362:55	
RW-7	8.31	10.92	2.61	8.0	Off	P=1;D=10	1/28/09 18:00	1/21/09 18:00	427:40	
RW-8	9.30	11.16	1.86	9.0	Off	P=1;D=10	1/28/09 18:00	1/21/09 18:00	102:40	
RW-9	9.88	11.70	1.82	12.0	Off	P=7;D=15	1/28/09 18:00	1/21/09 18:00	17:00	Skimmer pumping water, changed out skimmer.
MW-3	11.07	12.51	1.44		NA	NA		NA		Removed 3 gal of product.
Depth to product in Convault 1.84 ft Depth to interface in Convault 2.48 ft Approximate total liquid volume recovered 165 gal Approximate product volume recovered 168 gal										Ingersoll-Rand tech on-site to repair air dryer.

Site Visit Date: 02/10/09										
Recovery Well	Depth to Product (ft)	Depth to Water (ft)	Product Thickness (ft)	Depth of Pump (ft)	Vacuum (in/H ₂ O)	Cycles/Period and Duration	Last Run	Start Time	Total Time (hr:min)	Comments
RW-1	--	--	--		Off	Off		3/29/07 14:01		
RW-2	--	--	--		Off	Off		NA		
RW-3	11.39	11.49	0.10	11.0	Off	P=14;D=10	2/4/09 18:00	1/21/09 18:00	24:40	
RW-4	10.50	11.95	1.45	10.0	Off	P=7;D=15	2/4/09 18:00	1/21/09 18:00	91:15	
RW-5	--	--	--		Off	Off		8/24/07 18:07		
RW-6	9.12	9.68	0.56	9.0	Off	P=1;D=10	2/9/09 18:00	1/21/09 18:00	363:55	
RW-7	8.40	9.84	1.44	8.0	Off	P=1;D=10	2/9/09 18:00	1/21/09 18:00	20:40	
RW-8	9.48	9.95	0.47	9.0	Off	P=1;D=10	2/9/09 18:00	1/21/09 18:00	103:40	
RW-9	10.00	11.06	1.06	10.5	Off	P=7;D=15	2/4/09 18:00	1/21/09 18:00	17:15	Adjusted tag on skimmer line to read correct depth to pump inlet.
MW-3	11.17	13.22	2.05		NA	NA		NA		Removed 9 gal of product.
Depth to product in Convault 1.71 ft Depth to interface in Convault 2.37 ft Approximate total liquid volume recovered 199 gal Approximate product volume recovered 173 gal										Grease compressor fittings.

TABLE 3. Free Product Removal System Operation and Maintenance Records Summary
January 8 through June 30, 2009
Port of Oakland's Harbor Facilities Complex Site
555 - 651 Maritime Street, Oakland, California

Site Visit Date: 02/24/09										
Recovery Well	Depth to Product (ft)	Depth to Water (ft)	Product Thickness (ft)	Depth of Pump (ft)	Vacuum (in/H ₂ O)	Cycles/Period and Duration	Last Run	Start Time	Total Time (hr:min)	Comments
RW-1	--	--	--		Off	Off		3/29/07 14:01		
RW-2	--	--	--		Off	Off		NA		
RW-3	9.32	12.30	2.98	11.0	Off	Off		1/21/09 18:00		
RW-4	8.97	10.35	1.38	9.5	Off	Off		1/21/09 18:00		
RW-5	--	--	--		Off	Off		8/24/07 18:07		Vault covered by truck.
RW-6	8.75	10.02	1.27	9.0	Off	Off		1/21/09 18:00		
RW-7	8.08	8.68	0.60	9.0	Off	Off		1/21/09 18:00		
RW-8	9.10	9.70	0.60	9.0	Off	Off		1/21/09 18:00		
RW-9	9.60	10.69	1.09	10.5	Off	Off		1/21/09 18:00		
MW-3	9.38	10.34	0.96		NA	NA		NA		Removed 2.5 gal of product.
Depth to product in Convault 1.60 ft Depth to interface in Convault 2.30 ft Approximate total liquid volume recovered 228 gal Approximate product volume recovered 183 gal									Turned off system 2/17/09 due to rain and potential rapid groundwater level rise and to evaluate product recovery.	
Site Visit Date: 02/25/09										
Recovery Well	Depth to Product (ft)	Depth to Water (ft)	Product Thickness (ft)	Depth of Pump (ft)	Vacuum (in/H ₂ O)	Cycles/Period and Duration	Last Run	Start Time	Total Time (hr:min)	Comments
RW-1	--	--	--		Off	Off		3/29/07 14:01		
RW-2	--	--	--		Off	Off		NA		
RW-3	9.60	9.78	0.18	11.0	Off	Off		1/21/09 18:00		Purged RW-3 for 3/4 of an hour, then measured product/water level.
RW-4	--	--	--	9.5	Off	Off		1/21/09 18:00		
RW-5	--	--	--		Off	Off		8/24/07 18:07		
RW-6	--	--	--	9.0	Off	Off		1/21/09 18:00		Skimmer pumping water, changed out skimmer, purged for 10 minutes.
RW-7	--	--	--	9.0	Off	Off		1/21/09 18:00		
RW-8	--	--	--	9.0	Off	Off		1/21/09 18:00		
RW-9	--	--	--	10.5	Off	Off		1/21/09 18:00		
MW-3	--	--	--		NA	NA		NA		
Depth to product in Convault 1.59 ft Depth to interface in Convault 2.25 ft Approximate total liquid volume recovered 230 gal Approximate product volume recovered 173 gal									Turned off system 2/17/09 due to rain and potential rapid groundwater level rise and to evaluate product recovery.	

TABLE 3. Free Product Removal System Operation and Maintenance Records Summary
January 8 through June 30, 2009
Port of Oakland's Harbor Facilities Complex Site
555 - 651 Maritime Street, Oakland, California

Site Visit Date: 03/04/09										
Recovery Well	Depth to Product (ft)	Depth to Water (ft)	Product Thickness (ft)	Depth of Pump (ft)	Vacuum (in/H ₂ O)	Cycles/Period and Duration	Last Run	Start Time	Total Time (hr:min)	Comments
RW-1	7.65	7.67	0.02		Off	Off		3/29/07 14:01		
RW-2	NP	5.96	0.00		Off	Off		NA		
RW-3	9.19	12.14	2.95	10.0	Off	Off		1/21/09 18:00		Purged well for one hour, product thickness reduced to 0.7 ft.
RW-4	8.93	9.03	0.10	9.5	Off	Off		1/21/09 18:00		
RW-5	8.00	8.61	0.61		Off	Off		8/24/07 18:07		
RW-6	8.69	9.45	0.76	9.0	Off	Off		1/21/09 18:00		
RW-7	8.03	8.22	0.19	9.0	Off	Off		1/21/09 18:00		
RW-8	9.08	9.46	0.38	9.0	Off	Off		1/21/09 18:00		
RW-9	9.50	10.34	0.84	10.5	Off	Off		1/21/09 18:00		
MW-3	9.31	9.93	0.62		NA	NA		NA		Removed 1.5 gal of product.
Depth to product in Convault				1.60	ft					
Depth to interface in Convault				2.31	ft					
Approximate total liquid volume recovered				228	gal					
Approximate product volume recovered				186	gal					

Site Visit Date: 03/13/09										
Recovery Well	Depth to Product (ft)	Depth to Water (ft)	Product Thickness (ft)	Depth of Pump (ft)	Vacuum (in/H ₂ O)	Cycles/Period and Duration	Last Run	Start Time	Total Time (hr:min)	Comments
RW-1	--	--	--		Off	Off		3/29/07 14:01		
RW-2	NP	8.30	0.00		Off	Off		NA		
RW-3	9.75	11.79	2.04	10.0	Off	Off		1/21/09 18:00		
RW-4	9.25	9.32	0.07	10.0	Off	Off		1/21/09 18:00		
RW-5	8.15	8.72	0.57		Off	Off		8/24/07 18:07		
RW-6	8.72	9.57	0.85	10.0	Off	Off		1/21/09 18:00		
RW-7	8.12	8.31	0.19	9.0	Off	Off		1/21/09 18:00		
RW-8	9.04	9.45	0.41	9.0	Off	Off		1/21/09 18:00		
RW-9	9.41	10.25	0.84	10.5	Off	Off		1/21/09 18:00		
MW-3	9.88	10.79	0.91		NA	NA		NA		Removed 1.25 gal of product.
Depth to product in Convault				1.58	ft					
Depth to interface in Convault				2.26	ft					
Approximate total liquid volume recovered				233	gal					
Approximate product volume recovered				178	gal					

TABLE 3. Free Product Removal System Operation and Maintenance Records Summary
January 8 through June 30, 2009
Port of Oakland's Harbor Facilities Complex Site
555 - 651 Maritime Street, Oakland, California

Site Visit Date: 03/18/09										
Recovery Well	Depth to Product (ft)	Depth to Water (ft)	Product Thickness (ft)	Depth of Pump (ft)	Vacuum (in/H ₂ O)	Cycles/Period and Duration	Last Run	Start Time	Total Time (hr:min)	Comments
RW-1	--	--	--		Off	Off		3/29/07 14:01		
RW-2	--	--	--		Off	Off		NA		
RW-3	9.90	11.92	2.02	10.0	Off	P=7;D=15	1/21/09 18:00	1/21/09 18:00	24:20	Skimmer pumping water, changed out skimmer.
RW-4	9.40	9.50	0.10	10.0	Off	Off	1/28/09 18:00	1/21/09 18:00	90:30	
RW-5	--	--	--		Off	Off		8/24/07 18:07		
RW-6	8.73	9.59	0.86	9.0	10	P=7;D=15	1/28/09 18:00	1/21/09 18:00	326:10	
RW-7	8.15	8.32	0.17	8.0	10	P=7;D=15	1/28/09 18:00	1/21/09 18:00	426:90	Replaced filter and hose to float.
RW-8	9.06	9.46	0.40	8.0	12	P=7;D=15	1/28/09 18:00	1/21/09 18:00	102:10	Replaced filter and hose to float.
RW-9	9.41	10.28	0.87	10.5	Off	P=7;D=15	1/28/09 18:00	1/21/09 18:00	16:30	
MW-3	10.05	10.78	0.73		NA	NA		NA		Removed 4 gal of product.
Depth to product in Convault 1.56 ft Depth to interface in Convault 2.28 ft Approximate total liquid volume recovered 238 gal Approximate product volume recovered 188 gal										Restarted system and applied vacuum to RW-6, RW-7, and RW-8.

Site Visit Date: 03/26/09										
Recovery Well	Depth to Product (ft)	Depth to Water (ft)	Product Thickness (ft)	Depth of Pump (ft)	Vacuum (in/H ₂ O)	Cycles/Period and Duration	Last Run	Start Time	Total Time (hr:min)	Comments
RW-1	--	--	--		Off	Off		3/29/07 14:01		
RW-2	--	--	--		Off	Off		NA		
RW-3	10.30	10.92	0.62	10.0	Off	P=7;D=15	3/25/09 18:00	1/21/09 18:00	24:20	
RW-4	9.52	9.53	0.01	10.0	Off	Off		1/21/09 18:00	90:30	
RW-5	8.22	8.72	0.50		Off	Off		8/24/07 18:07		
RW-6	8.39	9.45	1.06	8.0	7	P=7;D=15	3/25/09 18:00	1/21/09 18:00	326:10	
RW-7	7.38	7.54	0.16	8.0	12 → 10	P=7;D=15	3/25/09 18:00	1/21/09 18:00	426:90	Adjust vacuum at well head.
RW-8	9.25	9.60	0.35	8.0	1 → 8	P=7;D=15	3/25/09 18:00	1/21/09 18:00	102:10	Adjust vacuum at well head.
RW-9	9.44	9.70	0.26	10.5	Off	P=7;D=15	3/25/09 18:00	1/21/09 18:00	16:30	
MW-3	10.22	10.88	0.66		NA	NA		NA		Removed 2 gal of product.
Depth to product in Convault 1.53 ft Depth to interface in Convault 2.28 ft Approximate total liquid volume recovered 246 gal Approximate product volume recovered 196 gal										Removed ORC sock from MW-4, DO reading 16.02 mg/L.

**TABLE 3. Free Product Removal System Operation and Maintenance Records Summary
January 8 through June 30, 2009
Port of Oakland's Harbor Facilities Complex Site
555 - 651 Maritime Street, Oakland, California**

Site Visit Date: 04/01/09										
Recovery Well	Depth to Product (ft)	Depth to Water (ft)	Product Thickness (ft)	Depth of Pump (ft)	Vacuum (in/H ₂ O)	Cycles/Period and Duration	Last Run	Start Time	Total Time (hr:min)	Comments
RW-1	NP	8.03	0.00		Off	Off		3/29/07 14:01		
RW-2	NP	9.35	0.00		Off	Off		NA		
RW-3	10.35	11.00	0.65	10.0	Off	P=7;D=15	3/25/09 18:00	1/21/09 18:00	24:20	
RW-4	9.66	9.72	0.06	10.0	Off	Off	3/11/09 18:00	1/21/09 18:00	90:30	
RW-5	--	--	--		Off	Off		8/24/07 18:07		Vault covered by truck.
RW-6	8.38	9.46	1.08	8.0	7	P=7;D=15	3/25/09 18:00	1/21/09 18:00	326:10	
RW-7	7.75	7.90	0.15	8.0	6	P=7;D=15	3/25/09 18:00	1/21/09 18:00	426:90	
RW-8	9.18	9.58	0.40	9.0	2 → 3	P=7;D=15	3/25/09 18:00	1/21/09 18:00	102:10	
RW-9	9.48	9.75	0.27	10.5	10.5	P=7;D=15	3/25/09 18:00	1/21/09 18:00	16:30	
MW-3	10.38	11.10	0.72		NA	NA		NA		Removed 1.2 gal of product.
Depth to product in Convault					1.52	ft				
Depth to interface in Convault					2.28	ft				
Approximate total liquid volume recovered					249	gal	Shut off vacuum system due to breakthrough above 10 ppm in first vessel.			
Approximate product volume recovered					199	gal				

Site Visit Date: 04/22/09										
Recovery Well	Depth to Product (ft)	Depth to Water (ft)	Product Thickness (ft)	Depth of Pump (ft)	Vacuum (in/H ₂ O)	Cycles/Period and Duration	Last Run	Start Time	Total Time (hr:min)	Comments
RW-1	--	--	--		Off	Off		3/29/07 14:01		
RW-2	--	--	--		Off	Off		NA		
RW-3	10.75	11.32	0.57	10.5	Off	P=7;D=15	4/15/09 18:00	1/21/09 18:00	25:55	Lower pump.
RW-4	9.83	9.86	0.03	10.0	Off	Off		1/21/09 18:00	91:30	
RW-5	8.48	8.97	0.49		Off	P=7;D=15	4/15/09 18:00	8/24/07 18:07		
RW-6	8.97	10.03	1.06	9.0	Off	P=7;D=15	4/15/09 18:00	1/21/09 18:00	366:20	Lower pump.
RW-7	8.29	8.53	0.24	8.0	Off	P=7;D=15	4/15/09 18:00	1/21/09 18:00	430:26	
RW-8	9.47	10.00	0.53	9.0	Off	P=7;D=15	4/15/09 18:00	1/21/09 18:00	106:50	
RW-9	9.87	10.51	0.64	10.5	Off	P=7;D=15	4/15/09 18:00	1/21/09 18:00	18:45	
MW-3	10.56	11.72	1.16		NA	NA		NA		Removed 2 gal of product.
Depth to product in Convault					1.51	ft				
Depth to interface in Convault					--	ft				
Approximate total liquid volume recovered					251	gal				
Approximate product volume recovered					--	gal				

TABLE 3. Free Product Removal System Operation and Maintenance Records Summary
January 8 through June 30, 2009
Port of Oakland's Harbor Facilities Complex Site
555 - 651 Maritime Street, Oakland, California

Site Visit Date: 05/04/09										
Recovery Well	Depth to Product (ft)	Depth to Water (ft)	Product Thickness (ft)	Depth of Pump (ft)	Vacuum (in/H ₂ O)	Cycles/Period and Duration	Last Run	Start Time	Total Time (hr:min)	Comments
RW-1	--	--	--		Off	Off		3/29/07 14:01		
RW-2	--	--	--		Off	Off		NA		
RW-3	10.82	11.41	0.59	11.0	Off	P=7;D=15	4/29/09 18:00	1/21/09 18:00		
RW-4	9.83	11.44	1.61	10.5	Off	Off		1/21/09 18:00		
RW-5	8.45	8.94	0.49		Off	P=7;D=15		8/24/07 18:07		
RW-6	8.45	10.06	1.61	9.0	6 → 10	P=7;D=15	4/29/09 18:00	1/21/09 18:00		
RW-7	7.20	7.94	0.74	8.0	16 → 10	P=7;D=15	4/29/09 18:00	1/21/09 18:00		
RW-8	9.23	9.93	0.70	9.0	3 → 10	P=7;D=15	4/29/09 18:00	1/21/09 18:00		
RW-9	9.87	10.64	0.77	10.0	Off	P=7;D=15	4/29/09 18:00	1/21/09 18:00		
MW-3	10.67	12.00	1.33		NA	NA		NA		Removed 2 gal of product.
Depth to product in Convault										1.50 ft
Depth to interface in Convault										-- ft
Approximate total liquid volume recovered										254 gal
Approximate product volume recovered										-- gal

Site Visit Date: 05/15/09										
Recovery Well	Depth to Product (ft)	Depth to Water (ft)	Product Thickness (ft)	Depth of Pump (ft)	Vacuum (in/H ₂ O)	Cycles/Period and Duration	Last Run	Start Time	Total Time (hr:min)	Comments
RW-1	--	--	--		Off	Off		3/29/07 14:01		
RW-2	--	--	--		Off	Off		NA		
RW-3	10.75	11.32	0.57	11.0	Off	P=7;D=15	5/13/09 18:00	1/21/09 18:00	26:55	
RW-4	9.83	9.86	0.03	10.5	Off	Off		1/21/09 18:00	92:00	
RW-5	8.48	8.97	0.49		Off	P=7;D=15		8/24/07 18:07		
RW-6	8.97	10.03	1.06	9.0	7	P=7;D=15	5/13/09 18:00	1/21/09 18:00	367:20	
RW-7	8.29	8.53	0.24	8.0	8	P=7;D=15	5/13/09 18:00	1/21/09 18:00	431:29	
RW-8	9.47	10.00	0.53	9.0	7	P=7;D=15	5/13/09 18:00	1/21/09 18:00	107:05	
RW-9	9.87	10.51	0.64	10.0	Off	P=7;D=15	5/13/09 18:00	1/21/09 18:00	19:45	
MW-3	10.56	11.72	1.16		NA	NA		NA		Removed 3 gal of product.
Depth to product in Convault										1.46 ft
Depth to interface in Convault										2.19 ft
Approximate total liquid volume recovered										264 gal
Approximate product volume recovered										191 gal

TABLE 3. Free Product Removal System Operation and Maintenance Records Summary
January 8 through June 30, 2009
Port of Oakland's Harbor Facilities Complex Site
555 - 651 Maritime Street, Oakland, California

Site Visit Date: 05/20/09										
Recovery Well	Depth to Product (ft)	Depth to Water (ft)	Product Thickness (ft)	Depth of Pump (ft)	Vacuum (in/H ₂ O)	Cycles/Period and Duration	Last Run	Start Time	Total Time (hr:min)	Comments
RW-1	--	--	--		Off	Off		3/29/07 14:01		
RW-2	NP	9.58	0.00		Off	Off		NA		
RW-3	10.94	11.41	0.47	11.0	Off	P=7;D=15	5/13/09 18:00	1/21/09 18:00	26:55	
RW-4	10.05	10.38	0.33	10.5	Off	Off		1/21/09 18:00	92:00	
RW-5	--	--	--		Off	P=7;D=15		8/24/07 18:07		Truck parked on top of vault.
RW-6	8.50	10.36	1.86	9.0	6	P=7;D=15	5/13/09 18:00	1/21/09 18:00	367:20	
RW-7	7.98	8.94	0.96	8.0	4 → 6	P=7;D=15	5/13/09 18:00	1/21/09 18:00	431:29	
RW-8	9.19	10.17	0.98	9.0	2 → 8	P=7;D=15	5/13/09 18:00	1/21/09 18:00	107:05	
RW-9	9.90	10.73	0.83	10.0	Off	P=7;D=15	5/13/09 18:00	1/21/09 18:00	19:45	
MW-3	10.72	12.00	1.28		NA	NA		NA		Removed 1 gallon of product.
Depth to product in Convault					1.43	ft				
Depth to interface in Convault					2.17	ft				
Approximate total liquid volume recovered					272	gal				
Approximate product volume recovered					194	gal				

Site Visit Date: 05/27/09										
Recovery Well	Depth to Product (ft)	Depth to Water (ft)	Product Thickness (ft)	Depth of Pump (ft)	Vacuum (in/H ₂ O)	Cycles/Period and Duration	Last Run	Start Time	Total Time (hr:min)	Comments
RW-1	--	--	--		Off	Off		3/29/07 14:01		
RW-2	--	--	--		Off	Off		NA		
RW-3	10.95	11.33	0.38	11.0	Off	P=7;D=15	5/20/09 18:00	1/21/09 18:00	27:10	
RW-4	10.03	10.54	0.51	10.5	Off	Off		1/21/09 18:00	92:15	
RW-5	--	--	--		Off	P=7;D=15		8/24/07 18:07		Truck parked on top of vault.
RW-6	8.52	10.41	1.89	9.0	6.5	P=7;D=15	5/20/09 18:00	1/21/09 18:00	367:35	
RW-7	7.82	8.99	1.17	8.0	6.2	P=7;D=15	5/20/09 18:00	1/21/09 18:00	431:44	
RW-8	8.59	9.71	1.12	9.0	8.0	P=7;D=15	5/20/09 18:00	1/21/09 18:00	107:20	
RW-9	9.92	10.81	0.89	10.0	Off	P=7;D=15	5/20/09 18:00	1/21/09 18:00	20:00	
MW-3	10.70	12.00	1.30		NA	NA		NA		Removed 1.5 gallons of product.
Depth to product in Convault					1.39	ft				
Depth to interface in Convault					2.10	ft				
Approximate total liquid volume recovered					283	gal				
Approximate product volume recovered					186	gal				

TABLE 3. Free Product Removal System Operation and Maintenance Records Summary
January 8 through June 30, 2009
Port of Oakland's Harbor Facilities Complex Site
555 - 651 Maritime Street, Oakland, California

Site Visit Date: 06/03/09										
Recovery Well	Depth to Product (ft)	Depth to Water (ft)	Product Thickness (ft)	Depth of Pump (ft)	Vacuum (in/H ₂ O)	Cycles/Period and Duration	Last Run	Start Time	Total Time (hr:min)	Comments
RW-1	--	--	--		Off	Off		3/29/07 14:01		
RW-2	--	--	--		Off	Off		NA		
RW-3	10.85	11.05	0.20	11.0	Off	P=7;D=15	5/27/09 18:00	1/21/09 18:00	27:25	
RW-4	10.04	10.69	0.65	10.5	Off	Off		1/21/09 18:00	92:30	
RW-5	--	--	--		Off	P=7;D=15		8/24/07 18:07		Truck parked on top of vault.
RW-6	8.65	10.53	1.88	9.0	6	P=7;D=15	5/27/09 18:00	1/21/09 18:00	367:50	
RW-7	7.89	9.26	1.37	8.0	5	P=7;D=15	5/27/09 18:00	1/21/09 18:00	431:59	
RW-8	9.95	10.31	0.36	9.0	2	P=7;D=15	5/27/09 18:00	1/21/09 18:00	107:35	
RW-9	9.65	10.73	1.08	10.0	Off	P=7;D=15	5/27/09 18:00	1/21/09 18:00	20:15	
MW-3	10.75	11.80	1.05		NA	NA		NA		Removed 1 gallon of product.
Depth to product in Convault					1.30	ft				
Depth to interface in Convault					2.07	ft				
Approximate total liquid volume recovered					306	gal				
Approximate product volume recovered					202	gal				

Site Visit Date: 06/10/09										
Recovery Well	Depth to Product (ft)	Depth to Water (ft)	Product Thickness (ft)	Depth of Pump (ft)	Vacuum (in/H ₂ O)	Cycles/Period and Duration	Last Run	Start Time	Total Time (hr:min)	Comments
RW-1	--	--	--		Off	Off		3/29/07 14:01		
RW-2	--	--	--		Off	Off		NA		
RW-3	10.90	11.05	0.15	11.0	Off	P=7;D=15	6/3/09 18:00	1/21/09 18:00	27:40	
RW-4	10.08	10.96	0.88	10.5	Off	Off		1/21/09 18:00	92:45	
RW-5	--	--	--		Off	P=7;D=15		8/24/07 18:07		Truck parked on top of vault.
RW-6	8.63	10.55	1.47	9.0	6.0	P=7;D=15	6/3/09 18:00	1/21/09 18:00	368:05	
RW-7	7.92	9.39	1.47	8.0	4.8	P=7;D=15	6/3/09 18:00	1/21/09 18:00	431:14	
RW-8	9.45	10.49	1.04	9.0	1.4	P=7;D=15	6/3/09 18:00	1/21/09 18:00	107:50	
RW-9	9.97	10.98	1.01	10.0	Off	P=7;D=15	6/3/09 18:00	1/21/09 18:00	20:30	
MW-3	10.74	12.14	1.40		NA	NA		NA		Removed 1 gallon of product.
Depth to product in Convault					1.29	ft				
Depth to interface in Convault					2.06	ft				
Approximate total liquid volume recovered					309	gal				
Approximate product volume recovered					202	gal				

TABLE 3. Free Product Removal System Operation and Maintenance Records Summary
January 8 through June 30, 2009
Port of Oakland's Harbor Facilities Complex Site
555 - 651 Maritime Street, Oakland, California

Site Visit Date: 06/17/09										
Recovery Well	Depth to Product (ft)	Depth to Water (ft)	Product Thickness (ft)	Depth of Pump (ft)	Vacuum (in/H ₂ O)	Cycles/Period and Duration	Last Run	Start Time	Total Time (hr:min)	Comments
RW-1	--	--	--		Off	Off		3/29/07 14:01		
RW-2	--	--	--		Off	Off		NA		
RW-3	10.93	11.02	0.09	11.0	Off	P=7;D=15	6/10/09 18:00	1/21/09 18:00	27:55	
RW-4	10.07	11.00	0.93	10.5	Off	Off		1/21/09 18:00	93:00	
RW-5	--	--	--		Off	P=7;D=15		8/24/07 18:07		Truck parked on top of vault.
RW-6	8.63	10.55	1.47	9.0	5.4	P=7;D=15	6/10/09 18:00	1/21/09 18:00	368:20	
RW-7	7.95	9.41	1.46	8.0	4.2	P=7;D=15	6/10/09 18:00	1/21/09 18:00	432:29	
RW-8	9.19	10.28	1.09	9.0	1.5	P=7;D=15	6/10/09 18:00	1/21/09 18:00	108:05	Increased vacuum on well to 1.5 in H ₂ O
RW-9	9.96	11.17	1.21	10.0	Off	P=7;D=15	6/10/09 18:00	1/21/09 18:00	20:45	
MW-3	10.79	12.30	1.51		NA	NA		NA		Removed 1 gallon of product.
Depth to product in Convault					1.25	ft				
Depth to interface in Convault					2.03	ft				
Approximate total liquid volume recovered					319	gal				
Approximate product volume recovered					204	gal				

Site Visit Date: 06/24/09										
Recovery Well	Depth to Product (ft)	Depth to Water (ft)	Product Thickness (ft)	Depth of Pump (ft)	Vacuum (in/H ₂ O)	Cycles/Period and Duration	Last Run	Start Time	Total Time (hr:min)	Comments
RW-1	--	--	--		Off	Off		3/29/07 14:01		
RW-2	--	--	--		Off	Off		NA		
RW-3	10.96	11.07	0.11	11.0	Off	P=7;D=15	6/17/09 18:00	1/21/09 18:00	28:10	
RW-4	10.15	11.12	0.97	10.5	Off	Off		1/21/09 18:00	93:15	
RW-5	--	--	--		Off	P=7;D=15		8/24/07 18:07		Truck parked on top of vault.
RW-6	8.60	10.59	1.47	9.0	5.4	P=7;D=15	6/17/09 18:00	1/21/09 18:00	368:55	
RW-7	7.75	9.64	1.89	8.0	6.4	P=7;D=15	6/17/09 18:00	1/21/09 18:00	432:44	
RW-8	9.16	10.37	1.21	9.0	5.0	P=7;D=15	6/17/09 18:00	1/21/09 18:00	108:20	
RW-9	--	--	--	10.0	Off	P=7;D=15	6/17/09 18:00	1/21/09 18:00	21:00	Unable to measure product/water levels due to equipment placed on well
MW-3	10.80	12.39	1.59		NA	NA		NA		Removed 1.5 gallons of product.
Depth to product in Convault					1.22	ft				
Depth to interface in Convault					2.03	ft				
Approximate total liquid volume recovered					327	gal				
Approximate product volume recovered					212	gal				

TABLE 3. Free Product Removal System Operation and Maintenance Records Summary
January 8 through June 30, 2009
Port of Oakland's Harbor Facilities Complex Site
555 - 651 Maritime Street, Oakland, California

Notes:

NP = no product

ft = ft

-- = not measured

gal = gallons

in/H₂O = inches of water

hr:min = hours:minutes

**TABLE 3. Free Product Recovery System Groundwater Elevation and Free Product Data
January 1, 2010 Through June 30, 2010
Port of Oakland's Harbor Facilities Complex Site
555 - 651 Maritime Street, Oakland, California**

Recovery Well	Date Measured	Elevation ¹ Top of Casing (feet)	Depth to Product (feet btc)	Depth to Water (feet btc)	Product Thickness (feet)	Groundwater Elevation ¹ (feet)
RW-1						
Well inaccessible; product and water levels not measured						
RW-2						
Well inaccessible; product and water levels not measured						
RW-3						
	7/1/2009	15.56	10.94	11.05	0.11	4.51
	7/8/2009	15.56	10.96	11.05	0.09	4.51
	7/15/2009	15.56	11.10	11.26	0.16	4.30
	7/22/2009	15.56	11.04	11.10	0.06	4.46
	7/29/2009	15.56	11.01	11.06	0.05	4.50
	8/5/2009	15.56	11.10	11.14	0.04	4.42
	8/12/2009	15.56	11.11	11.15	0.04	4.41
	8/19/2009	15.56	11.11	11.13	0.02	4.43
	8/26/2009	15.56	11.23	11.25	0.02	4.31
	9/2/2009	15.56	11.20	11.22	0.02	4.34
	9/16/2009	15.56	11.27	11.29	0.02	4.27
	9/23/2009	15.56	11.25	11.28	0.03	4.28
	9/30/2009	15.56	11.30	11.35	0.05	4.21
	10/7/2009	15.56	11.31	11.33	0.02	4.23
	10/14/2009	15.56	10.90	11.64	0.74	3.92
	10/21/2009	15.56	10.74	11.34	0.60	4.22
	10/28/2009	15.56	10.78	11.22	0.44	4.34
	11/4/2009	15.56	10.83	11.24	0.41	4.32
	11/18/2009	15.56	11.12	11.43	0.31	4.13
	11/25/2009	15.56	11.16	11.49	0.33	4.07
	12/1/2009	15.56	11.11	11.51	0.40	4.05
	12/9/2009	15.56	11.28	11.78	0.50	3.78
	12/16/2009	15.56	10.81	11.79	0.98	3.77
	12/23/2009	15.56	10.86	11.36	0.50	4.20
	12/30/2009	15.56	10.85	11.23	0.38	4.33
RW-4						
	7/1/2009	14.92	10.10	11.32	1.22	3.60
	7/8/2009	14.92	10.11	11.29	1.18	3.63
	7/15/2009	14.92	10.21	10.37	0.16	4.55
	7/22/2009	14.92	10.18	11.39	1.21	3.53
	7/29/2009	14.92	10.24	10.83	0.59	4.09
	8/5/2009	14.92	10.31	10.88	0.57	4.04
	8/12/2009	14.92	10.28	11.27	0.99	3.65
	8/19/2009	14.92	10.27	11.33	1.06	3.59
	8/26/2009	14.92	10.39	11.18	0.79	3.74
	9/2/2009	14.92	10.35	11.22	0.87	3.70
	9/16/2009	14.92	10.50	10.98	0.48	3.94
	9/23/2009	14.92	10.45	11.09	0.64	3.83
	9/30/2009	14.92	10.52	11.34	0.82	3.58
	10/7/2009	14.92	10.44	11.65	1.21	3.27
	10/14/2009	14.92	10.36	11.22	0.86	3.70

**TABLE 3. Free Product Recovery System Groundwater Elevation and Free Product Data
January 1, 2010 Through June 30, 2010
Port of Oakland's Harbor Facilities Complex Site
555 - 651 Maritime Street, Oakland, California**

Recovery Well	Date Measured	Elevation ¹ Top of Casing (feet)	Depth to Product (feet btc)	Depth to Water (feet btc)	Product Thickness (feet)	Groundwater Elevation ¹ (feet)
	10/21/2009	14.92	10.03	10.43	0.40	4.49
	10/28/2009	14.92	10.02	10.56	0.54	4.36
	11/4/2009	14.92	10.06	10.78	0.72	4.14
	11/18/2009	14.92	10.29	11.25	0.96	3.67
	11/25/2009	14.92	10.32	11.48	1.16	3.44
	12/1/2009	14.92	10.22	11.52	1.30	3.40
	12/9/2009	14.92	10.45	10.75	0.30	4.17
	12/16/2009	14.92	10.14	10.53	0.39	4.39
	12/23/2009	14.92	10.13	10.51	0.38	4.41
	12/30/2009	14.92	10.18	10.62	0.44	4.30
RW-5						
Well inaccessible; product and water levels not measured						
RW-6						
	7/1/2009	15.75	8.64	10.62	1.98	5.13
	7/8/2009	15.75	8.58	10.67	2.09	5.08
	7/15/2009	15.75	8.70	10.80	2.10	4.95
	7/22/2009	15.75	8.75	10.90	2.15	4.85
	7/29/2009	15.75	8.77	10.95	2.18	4.80
	8/5/2009	15.75	8.73	10.93	2.20	4.82
	8/12/2009	15.75	8.75	10.96	2.21	4.79
	8/19/2009	15.75	8.81	11.08	2.27	4.67
	8/26/2009	15.75	8.86	11.11	2.25	4.64
	9/2/2009	15.75	8.80	11.13	2.33	4.62
	9/16/2009	15.75	8.81	11.19	2.38	4.56
	9/23/2009	15.75	8.88	11.27	2.39	4.48
	9/30/2009	15.75	8.70	10.23	1.53	5.52
	10/7/2009	15.75	8.91	11.45	2.54	4.30
	10/14/2009	15.75	8.55	11.25	2.70	4.50
	10/21/2009	15.75	8.85	11.09	2.24	4.66
	10/28/2009	15.75	8.87	10.87	2.00	4.88
	11/4/2009	15.75	8.93	10.92	1.99	4.83
	11/18/2009	15.75	9.04	11.12	2.08	4.63
	11/25/2009	15.75	9.08	11.16	2.08	4.59
	12/1/2009	15.75	9.08	11.15	2.07	4.60

**TABLE 3. Free Product Recovery System Groundwater Elevation and Free Product Data
January 1, 2010 Through June 30, 2010
Port of Oakland's Harbor Facilities Complex Site
555 - 651 Maritime Street, Oakland, California**

Recovery Well	Date Measured	Elevation ¹ Top of Casing (feet)	Depth to Product (feet btc)	Depth to Water (feet btc)	Product Thickness (feet)	Groundwater Elevation ¹ (feet)
RW-6 (cont)	12/9/2009	15.75	9.15	10.90	1.75	4.85
	12/16/2009	15.75	8.97	10.85	1.88	4.90
	12/23/2009	15.75	8.69	10.84	2.15	4.91
	12/30/2009	15.75	8.72	10.74	2.02	5.01
RW-7						
	7/1/2009	15.02	8.02	9.88	1.86	5.14
	7/8/2009	15.02	7.98	9.90	1.92	5.12
	7/15/2009	15.02	8.10	10.07	1.97	4.95
	7/22/2009	15.02	7.95	10.10	2.15	4.92
	7/29/2009	15.02	8.29	10.16	1.87	4.86
	8/5/2009	15.02	8.26	10.26	2.00	4.76
	8/12/2009	15.02	8.20	10.27	2.07	4.75
	8/19/2009	15.02	7.98	10.39	2.41	4.63
	8/26/2009	15.02	7.75	10.52	2.77	4.50
	9/2/2009	15.02	8.08	10.55	2.47	4.47
	9/16/2009	15.02	7.74	10.81	3.07	4.21
	9/23/2009	15.02	8.19	10.61	2.42	4.41
	9/30/2009	15.02	7.95	10.78	2.83	4.24
	10/7/2009	15.02	7.95	11.00	3.05	4.02
	10/14/2009	15.02	7.78	11.25	3.47	3.77
	10/21/2009	15.02	8.02	10.45	2.43	4.57
	10/28/2009	15.02	8.09	10.20	2.11	4.82
	11/4/2009	15.02	8.02	10.51	2.49	4.51
	11/18/2009	15.02	7.74	10.71	2.97	4.31
	11/25/2009	15.02	8.15	10.78	2.63	4.24
	12/1/2009	15.02	7.76	10.80	3.04	4.22
	12/9/2009	15.02	7.96	10.82	2.86	4.20
	12/16/2009	15.02	7.85	10.11	2.26	4.91
	12/23/2009	15.02	8.02	10.33	2.31	4.69
	12/30/2009	15.02	8.01	10.23	2.22	4.79
RW-8						
	7/1/2009	15.91	9.14	10.55	1.41	5.36
	7/8/2009	15.91	9.16	10.63	1.47	5.28
	7/15/2009	15.91	9.21	10.74	1.53	5.17
	7/22/2009	15.91	9.20	10.70	1.50	5.21
	7/29/2009	15.91	9.22	10.85	1.63	5.06
	8/5/2009	15.91	9.60	10.90	1.30	5.01
	8/12/2009	15.91	9.32	10.93	1.61	4.98
	8/19/2009	15.91	9.38	10.93	1.55	4.98
	8/26/2009	15.91	9.39	11.02	1.63	4.89
	9/2/2009	15.91	9.41	11.12	1.71	4.79
	9/16/2009	15.91	9.42	11.24	1.82	4.67
	9/23/2009	15.91	9.49	11.26	1.77	4.65
	9/30/2009	15.91	9.48	11.12	1.64	4.79
	10/7/2009	15.91	9.52	11.33	1.81	4.58
RW-8 (cont)	10/14/2009	15.91	9.08	10.84	1.76	5.07

**TABLE 3. Free Product Recovery System Groundwater Elevation and Free Product Data
January 1, 2010 Through June 30, 2010
Port of Oakland's Harbor Facilities Complex Site
555 - 651 Maritime Street, Oakland, California**

Recovery Well	Date Measured	Elevation ¹ Top of Casing (feet)	Depth to Product (feet btc)	Depth to Water (feet btc)	Product Thickness (feet)	Groundwater Elevation ¹ (feet)
	10/21/2009	15.91	9.60	11.07	1.47	4.84
	10/28/2009	15.91	9.52	10.38	0.86	5.53
	11/4/2009	15.91	9.54	10.41	0.87	5.50
	11/18/2009	15.91	9.49	10.85	1.36	5.06
	11/25/2009	15.91	9.55	10.72	1.17	5.19
	12/1/2009	15.91	9.61	10.58	0.97	5.33
	12/9/2009	15.91	9.65	10.50	0.85	5.41
	12/16/2009	15.91	9.60	10.29	0.69	5.62
	12/23/2009	15.91	9.45	10.25	0.80	5.66
	12/30/2009	15.91	9.46	10.31	0.85	5.60
RW-9						
	7/8/2009	16.57	10.09	11.11	1.02	5.46
	7/15/2009	16.57	10.83	10.89	0.06	5.68
	7/22/2009	16.57	9.86	10.78	0.92	5.79
	7/29/2009	16.57	9.90	10.79	0.89	5.78
	8/5/2009	16.57	9.95	10.59	0.64	5.98
	8/12/2009	16.57	9.99	10.40	0.41	6.17
	8/19/2009	16.57	9.98	10.51	0.53	6.06
	8/26/2009	16.57	10.02	10.66	0.64	5.91
	9/2/2009	16.57	10.02	10.73	0.71	5.84
	9/16/2009	16.57	10.06	10.60	0.54	5.97
	9/23/2009	16.57	10.08	10.60	0.52	5.97
	9/30/2009	16.57	10.11	10.60	0.49	5.97
	10/7/2009	16.57	10.13	10.65	0.52	5.92
	10/14/2009	16.57	10.11	10.58	0.47	5.99
	10/21/2009	16.57	9.92	10.37	0.45	6.20
	10/28/2009	16.57	9.89	10.36	0.47	6.21
	11/4/2009	16.57	9.91	10.50	0.59	6.07
	11/18/2009	16.57	10.00	10.56	0.56	6.01
	11/25/2009	16.57	10.04	10.56	0.52	6.01
	12/1/2009	16.57	10.06	10.55	0.49	6.02
	12/9/2009	16.57	10.18	10.39	0.21	6.18
	12/16/2009	16.57	9.98	10.22	0.24	6.35
	12/23/2009	16.57	10.15	10.48	0.33	6.09
	12/30/2009	16.57	10.13	10.50	0.37	6.07

**TABLE 3. Free Product Recovery System Groundwater Elevation and Free Product Data
January 1, 2010 Through June 30, 2010
Port of Oakland's Harbor Facilities Complex Site
555 - 651 Maritime Street, Oakland, California**

Recovery Well	Date Measured	Elevation ¹ Top of Casing (feet)	Depth to Product (feet btc)	Depth to Water (feet btc)	Product Thickness (feet)	Groundwater Elevation ¹ (feet)
MW-3						
	7/8/2009	15.66	10.80	12.39	1.59	3.27
	7/15/2009	15.66	10.85	12.41	1.56	3.25
	7/22/2009	15.66	10.86	12.68	1.82	2.98
	7/29/2009	15.66	10.89	12.65	1.76	3.01
	8/5/2009	15.66	10.87	12.54	1.67	3.12
	8/12/2009	15.66	10.93	12.69	1.76	2.97
	8/19/2009	15.66	10.97	12.84	1.87	2.82
	8/26/2009	15.66	10.96	12.75	1.79	2.91
	9/2/2009	15.66	10.99	12.94	1.95	2.72
	9/16/2009	15.66	11.00	12.94	1.94	2.72
	9/23/2009	15.66	11.10	13.16	2.06	2.5
	9/30/2009	15.66	11.08	13.07	1.99	2.59
	10/7/2009	15.66	11.06	13.15	2.09	2.51
	10/14/2009	15.66	11.13	13.16	2.03	2.50
	10/21/2009	15.66	10.66	12.00	1.34	3.66
	10/28/2009	15.66	10.74	11.64	0.90	4.02
	11/4/2009	15.66	10.72	11.74	1.02	3.92
	11/18/2009	15.66	10.75	11.82	1.07	3.84
	11/25/2009	15.66	11.24	11.40	0.16	4.26
	12/1/2009	15.66	11.01	12.64	1.63	3.02
	12/9/2009	15.66	11.03	12.47	1.44	3.19
	12/16/2009	15.66	11.05	12.81	1.76	2.85
	12/23/2009	15.66	10.69	11.71	1.02	3.95
	12/30/2009	15.66	10.75	11.67	0.92	3.99

**TABLE 3. Free Product Recovery System Groundwater Elevation and Free Product Data
January 1, 2010 Through December 29, 2010
Port of Oakland's Harbor Facilities Complex Site
555 - 651 Maritime Street, Oakland, California**

Recovery Well	Date Measured	Elevation ¹ Top of Casing (feet)	Depth to Product (feet btc)	Depth to Water (feet btc)	Product Thickness (feet)	Groundwater Elevation ¹ (feet)
RW-1						
Well inaccessible; product and water levels not measured						
RW-2						
	03/31/10	15.56	7.53 ³	7.53	0.00	8.03
	06/17/10	15.56	NP	9.54	0.00	6.02
RW-3						
	01/06/10	15.56	10.85	11.13	0.28	4.43
	01/13/10	15.56	10.89	11.11	0.22	4.45
	01/20/10	15.56	9.36	10.65	1.29	4.91
	01/27/10	15.56	9.26	13.03	3.77	2.53
	02/03/10	15.56	9.51	12.20	2.69	3.36
	02/10/10	15.56	9.44	13.11	3.67	2.45
	02/17/10	15.56	9.75	12.29	2.54	3.27
	02/24/10	15.56	8.98	14.08	5.10	1.48
	03/02/10	15.56	8.92	12.78	3.86	2.78
	03/10/10	15.56	9.54	11.53	1.99	4.03
	03/17/10	15.56	9.57	12.40	2.83	3.16
	03/24/10	15.56	9.88	11.15	1.27	4.41
	03/31/10	15.56	NM	NM	NM	NM
	04/07/10	15.56	9.74	13.21	3.47	2.35
	04/14/10	15.56	9.43	13.38	3.95	2.18
	04/21/10	15.56	9.21	13.32	4.11	2.24
	04/28/10	15.56	9.73	11.98	2.25	3.58
	05/05/10	15.56	10.07	10.90	0.83	4.66
	05/12/10	15.56	10.22	10.65	0.43	4.91
	05/19/10	15.56	10.42	10.84	0.42	4.72
	05/26/10	15.56	10.38	10.63	0.25	4.93
	06/02/10	15.56	10.28	11.79	1.51	3.77
	06/09/10	15.56	10.41	11.65	1.24	3.91
	06/17/10	15.56	10.42	12.11	1.69	3.45
	06/23/10	15.56	10.46	11.63	1.17	3.93
	06/30/10	15.56	10.51	11.64	1.13	3.92
	07/07/10	15.56	10.51	11.78	1.27	3.78
	07/14/10	15.56	10.55	11.85	1.30	3.71
	07/21/10	15.56	10.60	11.44	0.84	4.12
	07/28/10	15.56	10.74	11.33	0.59	4.23
	08/11/10	15.56	10.81	11.19	0.38	4.37
	08/25/10	15.56	10.81	11.09	0.28	4.47
	09/01/10	15.56	10.89	11.08	0.19	4.48
	09/22/10	15.56	10.96	11.21	0.25	4.35
	10/06/10	15.56	11.12	11.30	0.18	4.26
	10/20/10	15.56	11.14	11.30	0.16	4.26
	11/03/10	15.56	10.99	11.72	0.73	3.84
	11/17/10	15.56	10.86	11.80	0.94	3.76

**TABLE 3. Free Product Recovery System Groundwater Elevation and Free Product Data
January 1, 2010 Through December 29, 2010
Port of Oakland's Harbor Facilities Complex Site
555 - 651 Maritime Street, Oakland, California**

Recovery Well	Date Measured	Elevation ¹ Top of Casing (feet)	Depth to Product (feet btc)	Depth to Water (feet btc)	Product Thickness (feet)	Groundwater Elevation ¹ (feet)
RW-3 (cont)	12/01/10	15.56	10.57	11.63	1.06	3.93
	12/15/10	15.56	10.14	11.34	1.20	4.22
	12/29/10	15.56	8.81	10.29	1.48	5.27
RW-4						
	01/06/10	14.92	10.09	10.69	0.60	4.23
	01/13/10	14.92	10.16	10.81	0.65	4.11
	01/20/10	14.92	9.13	9.86	0.73	5.06
	01/27/10	14.92	9.00	9.33	0.33	5.59
	02/03/10	14.92	9.12	9.33	0.21	5.59
	02/10/10	14.92	9.19	9.40	0.21	5.52
	02/17/10	14.92	9.30	10.01	0.71	4.91
	02/24/10	14.92	9.06	9.25	0.19	5.67
	03/10/10	14.92	8.97	9.14	0.17	5.78
	03/17/10	14.92	9.07	9.23	0.16	5.69
	03/24/10	14.92	9.25	9.41	0.16	5.51
	03/31/10	14.92	9.31	9.46	0.15	5.46
	04/07/10	14.92	9.36	9.51	0.15	5.41
	04/14/10	14.92	9.09	9.29	0.20	5.63
	04/21/10	14.92	8.95	9.14	0.19	5.78
	04/28/10	14.92	9.21	9.42	0.21	5.50
	05/05/10	14.92	9.37	9.69	0.32	5.23
	05/12/10	14.92	9.52	9.75	0.23	5.17
	05/19/10	14.92	9.66	9.91	0.25	5.01
	05/26/10	14.92	9.65	9.92	0.27	5.00
	06/02/10	14.92	9.69	9.82	0.13	5.10
	06/09/10	14.92	9.80	10.00	0.20	4.92
	06/17/10	14.92	9.82	10.14	0.32	4.78
	06/23/10	14.92	9.88	10.09	0.21	4.83
	06/30/10	14.92	9.89	10.16	0.27	4.76
	07/07/10	14.92	9.92	10.20	0.28	4.72
	07/14/10	14.92	9.94	10.29	0.35	4.63
	07/21/10	14.92	9.94	10.27	0.33	4.65
	07/28/10	14.92	10.04	10.38	0.34	4.54
	08/11/10	14.92	10.08	10.56	0.48	4.36
	08/25/10	14.92	10.05	10.77	0.72	4.15
	09/01/10	14.92	10.11	10.89	0.78	4.03
	09/22/10	14.92	10.17	11.31	1.14	3.61
	10/06/10	14.92	10.32	11.36	1.04	3.56
	10/20/10	14.92	10.31	11.42	1.11	3.50
	11/03/10	14.92	10.38	10.44	0.06	4.48
	11/17/10	14.92	10.28	10.59	0.31	4.33
	12/01/10	14.92	9.85	10.32	0.47	4.60
	12/15/10	14.92	9.42	10.50	1.08	4.42
	12/29/10	14.92	8.65	8.70	0.05	6.22

**TABLE 3. Free Product Recovery System Groundwater Elevation and Free Product Data
January 1, 2010 Through December 29, 2010
Port of Oakland's Harbor Facilities Complex Site
555 - 651 Maritime Street, Oakland, California**

Recovery Well	Date Measured	Elevation ¹ Top of Casing (feet)	Depth to Product (feet btc)	Depth to Water (feet btc)	Product Thickness (feet)	Groundwater Elevation ¹ (feet)
RW-5						
	01/20/10	14.79	7.54	9.37	1.83	5.42
	01/27/10	14.79	8.11	8.54	0.43	6.25
	02/03/10	14.79	6.60 ³	6.60	0.00	8.19
	02/10/10	14.79	6.52 ³	6.52	0.00	8.27
	06/17/10	14.79	6.70 ³	6.70	0.00	8.09
	06/23/10	14.79	7.85 ³	7.85	0.00	6.94
	07/14/10	14.79	7.84 ³	7.84	0.00	6.95
	07/21/10	14.79	6.60 ³	6.60	0.00	8.19
	08/25/10	14.79	6.89	9.23	2.34	5.56
	09/22/10	14.79	6.44	10.85	4.41	3.94
	10/20/10	14.79	6.42	13.13	6.71	1.66
	11/03/10	14.79	6.41	9.54	3.13	5.25
	12/01/10	14.79	6.41	9.57	3.16	5.22
	12/15/10	14.79	7.65	8.74	1.09	6.05
RW-6						
	01/06/10	15.75	8.70	10.74	2.04	5.01
	01/13/10	15.75	8.86	10.79	1.93	4.96
	01/20/10	15.75	8.58	10.58	2.00	5.17
	01/27/10	15.75	8.54	10.14	1.60	5.61
	02/03/10	15.75	8.55	9.81	1.26	5.94
	02/10/10	15.75	9.41	9.82	0.41	5.93
	02/17/10	15.75	8.62	9.44	0.82	6.31
	02/24/10	15.75	8.59	9.37	0.78	6.38
	03/10/10	15.75	8.53	9.14	0.61	6.61
	03/17/10	15.75	8.56	8.84	0.28	6.91
	03/24/10	15.75	8.68	8.91	0.23	6.84
	03/31/10	15.75	8.69	9.11	0.42	6.64
	04/07/10	15.75	8.59	9.21	0.62	6.54
	04/14/10	15.75	8.40	9.11	0.71	6.64
	04/21/10	15.75	8.39	8.92	0.53	6.83
	04/28/10	15.75	8.61	8.96	0.35	6.79
	05/05/10	15.75	8.62	8.94	0.32	6.81
	05/12/10	15.75	8.65	9.09	0.44	6.66
	05/19/10	15.75	8.64	9.35	0.71	6.40
	05/26/10	15.75	8.63	9.51	0.88	6.24
	06/02/10	15.75	8.56	9.55	0.99	6.20
	06/09/10	15.75	8.62	9.52	0.90	6.23
	06/17/10	15.75	8.65	9.62	0.97	6.13
	06/23/10	15.75	8.70	9.60	0.90	6.15
	06/30/10	15.75	8.55	9.65	1.10	6.10
	07/07/10	15.75	8.58	9.80	1.22	5.95
	07/14/10	15.75	8.59	9.88	1.29	5.87
	07/21/10	15.75	8.68	9.97	1.29	5.78

**TABLE 3. Free Product Recovery System Groundwater Elevation and Free Product Data
January 1, 2010 Through December 29, 2010
Port of Oakland's Harbor Facilities Complex Site
555 - 651 Maritime Street, Oakland, California**

Recovery Well	Date Measured	Elevation ¹ Top of Casing (feet)	Depth to Product (feet btc)	Depth to Water (feet btc)	Product Thickness (feet)	Groundwater Elevation ¹ (feet)
RW-6 (cont)	07/28/10	15.75	8.74	10.04	1.30	5.71
	08/11/10	15.75	8.78	10.14	1.36	5.61
	08/25/10	15.75	8.81	10.29	1.48	5.46
	09/01/10	15.75	8.81	10.42	1.61	5.33
	09/22/10	15.75	8.88	10.50	1.62	5.25
	10/06/10	15.75	8.93	10.64	1.71	5.11
	10/22/10	15.75	8.95	10.75	1.80	5.00
	11/03/10	15.75	8.84	10.61	1.77	5.14
	11/17/10	15.75	8.48	10.78	2.30	4.97
	12/01/10	15.75	8.55	10.42	1.87	5.33
	12/15/10	15.75	8.30	10.23	1.93	5.52
	12/29/10	15.75	7.85	9.79	1.94	5.96
RW-7						
	01/06/10	15.02	8.09	10.29	2.20	4.73
	01/13/10	15.02	8.00	10.56	2.56	4.46
	01/20/10	15.02	7.25	10.10	2.85	4.92
	01/27/10	15.02	7.71	9.14	1.43	5.88
	02/03/10	15.02	7.85	8.33	0.48	6.69
	02/10/10	15.02	7.89	8.45	0.56	6.57
	02/17/10	15.02	7.81	8.39	0.58	6.63
	02/24/10	15.02	7.15	8.30	1.15	6.72
	03/10/10	15.02	7.64	8.81	1.17	6.21
	03/17/10	15.02	7.79	8.05	0.26	6.97
	03/24/10	15.02	7.90	8.08	0.18	6.94
	03/31/10	15.02	7.96	8.15	0.19	6.87
	04/07/10	15.02	7.85	8.07	0.22	6.95
	04/14/10	15.02	7.78	7.99	0.21	7.03
	04/21/10	15.02	7.78	8.02	0.24	7.00
	04/28/10	15.02	7.85	8.20	0.35	6.82
	05/05/10	15.02	7.95	8.23	0.28	6.79
	05/12/10	15.02	7.60	7.92	0.32	7.10
	05/19/10	15.02	7.79	8.08	0.29	6.94
	05/26/10	15.02	7.66	7.98	0.32	7.04
	06/02/10	15.02	7.92	8.30	0.38	6.72
	06/09/10	15.02	8.01	8.45	0.44	6.57
	06/17/10	15.02	7.96	8.60	0.64	6.42
	06/23/10	15.02	8.04	8.83	0.79	6.19
	06/30/10	15.02	7.71	8.89	1.18	6.13
	07/07/10	15.02	7.83	8.98	1.15	6.04
	07/14/10	15.02	7.86	9.09	1.23	5.93
	07/21/10	15.02	7.63	9.13	1.50	5.89
	07/28/10	15.02	7.90	9.35	1.45	5.67
	08/11/10	15.02	7.87	9.59	1.72	5.43
	08/25/10	15.02	7.97	9.85	1.88	5.17

**TABLE 3. Free Product Recovery System Groundwater Elevation and Free Product Data
January 1, 2010 Through December 29, 2010
Port of Oakland's Harbor Facilities Complex Site
555 - 651 Maritime Street, Oakland, California**

Recovery Well	Date Measured	Elevation ¹ Top of Casing (feet)	Depth to Product (feet btc)	Depth to Water (feet btc)	Product Thickness (feet)	Groundwater Elevation ¹ (feet)
RW-7 (cont)	09/01/10	15.02	7.75	9.88	2.13	5.14
	09/22/10	15.02	7.77	10.09	2.32	4.93
	10/06/10	15.02	8.08	10.14	2.06	4.88
	10/20/10	15.02	8.00	10.21	2.21	4.81
	11/03/10	15.02	7.65	9.48	1.83	5.54
	11/17/10	15.02	7.20	10.48	3.28	4.54
	12/01/10	15.02	6.54	10.50	3.96	4.52
	12/15/10	15.02	7.70	9.76	2.06	5.26
	12/29/10	15.02	7.73	9.09	1.36	5.93
RW-8						
	01/06/10	15.91	9.46	10.30	0.84	5.61
	01/13/10	15.91	9.52	10.33	0.81	5.58
	01/20/10	15.91	9.35	9.90	0.55	6.01
	01/27/10	15.91	9.06	9.65	0.59	6.26
	02/03/10	15.91	9.26	9.84	0.58	6.07
	02/10/10	15.91	9.23	9.74	0.51	6.17
	02/17/10	15.91	9.12	9.56	0.44	6.35
	02/24/10	15.91	9.18	9.58	0.40	6.33
	03/10/10	15.91	9.10	9.41	0.31	6.50
	03/17/10	15.91	8.95	9.07	0.12	6.84
	03/24/10	15.91	9.12	9.19	0.07	6.72
	03/31/10	15.91	9.11	9.18	0.07	6.73
	04/07/10	15.91	9.10	9.15	0.05	6.76
	04/14/10	15.91	9.11	9.23	0.12	6.68
	04/21/10	15.91	9.07	9.24	0.17	6.67
	04/28/10	15.91	9.12	9.45	0.33	6.46
	05/05/10	15.91	9.14	9.33	0.19	6.58
	05/12/10	15.91	8.74	8.76	0.02	7.15
	05/19/10	15.91	9.23	9.31	0.08	6.60
	05/26/10	15.91	8.71	8.83	0.12	7.08
	06/02/10	15.91	9.13	10.25	1.12	5.66
	06/09/10	15.91	9.16	9.25	0.09	6.66
	06/17/10	15.91	9.13	9.24	0.11	6.67
	06/23/10	15.91	9.19	9.36	0.17	6.55
	06/30/10	15.91	9.20	9.41	0.21	6.50
	07/07/10	15.91	9.27	9.54	0.27	6.37
	07/14/10	15.91	9.23	9.53	0.30	6.38
	07/21/10	15.91	9.14	9.46	0.32	6.45
	07/28/10	15.91	9.12	9.51	0.39	6.40
	08/11/10	15.91	9.20	9.76	0.56	6.15
	08/25/10	15.91	9.25	10.05	0.80	5.86
	09/01/10	15.91	9.23	10.21	0.98	5.70
	09/22/10	15.91	9.41	10.44	1.03	5.47
	10/06/10	15.91	9.47	10.63	1.16	5.28
	10/20/10	15.91	9.47	10.84	1.37	5.07
	11/03/10	15.91	9.53	10.49	0.96	5.42

**TABLE 3. Free Product Recovery System Groundwater Elevation and Free Product Data
January 1, 2010 Through December 29, 2010
Port of Oakland's Harbor Facilities Complex Site
555 - 651 Maritime Street, Oakland, California**

Recovery Well	Date Measured	Elevation ¹ Top of Casing (feet)	Depth to Product (feet btc)	Depth to Water (feet btc)	Product Thickness (feet)	Groundwater Elevation ¹ (feet)
RW-8 (cont)	11/17/10	15.91	9.27	10.17	0.90	5.74
	12/01/10	15.91	9.25	10.26	1.01	5.65
	12/15/10	15.91	9.25	9.93	0.68	5.98
	12/29/10	15.91	8.41	9.22	0.81	6.69
RW-9						
	01/06/10	16.57	10.09	10.50	0.41	6.07
	01/13/10	16.57	10.70	11.29	0.59	5.28
	01/20/10	16.57	9.71	10.20	0.49	6.37
	01/27/10	16.57	9.54	9.87	0.33	6.70
	02/03/10	16.57	9.46	9.52	0.06	7.05
	02/10/10	16.57	9.52	9.59	0.07	6.98
	02/17/10	16.57	9.46	9.52	0.06	7.05
	02/24/10	16.57	9.47	9.52	0.05	7.05
	03/10/10	16.57	9.35	9.44	0.09	7.13
	03/17/10	16.57	9.32	9.39	0.07	7.18
	03/24/10	16.57	9.59	9.62	0.03	6.95
	03/31/10	16.57	9.35	9.38	0.03	7.19
	04/07/10	16.57	9.35	9.36	0.01	7.21
	04/14/10	16.57	9.32	9.35	0.03	7.22
	04/21/10	16.57	9.30	9.32	0.02	7.25
	04/28/10	16.57	9.29	9.36	0.07	7.21
	05/05/10	16.57	9.57	9.63	0.06	6.94
	05/12/10	16.57	9.34	9.39	0.05	7.18
	05/19/10	16.57	9.39	9.45	0.06	7.12
	05/26/10	16.57	9.41	9.50	0.09	7.07
	06/02/10	16.57	9.44	9.59	0.15	6.98
	06/09/10	16.57	9.49	9.56	0.07	7.01
	06/17/10	16.57	9.52	9.61	0.09	6.96
	06/23/10	16.57	9.55	9.60	0.05	6.97
	06/30/10	16.57	9.59	9.63	0.04	6.94
	07/07/10	16.57	9.62	9.67	0.05	6.90
	07/14/10	NM - inaccessible				
	07/21/10	NM - inaccessible				
	07/28/10	16.57	9.73	9.79	0.06	6.78
	08/11/10	16.57	9.78	10.02	0.24	6.55
	08/25/10	16.57	9.74	10.40	0.66	6.17
	09/01/10	16.57	9.82	10.15	0.33	6.42
	09/22/10	16.57	9.89	10.19	0.30	6.38
	10/06/10	16.57	9.94	10.26	0.32	6.31
	10/20/10	16.57	9.97	10.27	0.30	6.30
	11/03/10	16.57	9.86	10.16	0.30	6.41
	12/01/10	16.57	9.67	9.89	0.22	6.68
	12/15/10	16.57	9.56	9.76	0.20	6.81
	12/29/10	16.57	9.34	9.53	0.19	7.04

**TABLE 3. Free Product Recovery System Groundwater Elevation and Free Product Data
January 1, 2010 Through December 29, 2010
Port of Oakland's Harbor Facilities Complex Site
555 - 651 Maritime Street, Oakland, California**

Recovery Well	Date Measured	Elevation ¹ Top of Casing (feet)	Depth to Product (feet btc)	Depth to Water (feet btc)	Product Thickness (feet)	Groundwater Elevation ¹ (feet)
MW-3						
	01/06/10	15.66	10.78	11.85	1.07	3.81
	01/13/10	15.66	10.70	11.29	0.59	4.37
	01/20/10	15.66	9.31	10.00	0.69	5.66
	01/27/10	15.66	9.44	10.34	0.90	5.32
	02/03/10	15.66	9.71	10.47	0.76	5.19
	02/10/10	15.66	9.62	10.41	0.79	5.25
	02/17/10	15.66	9.95	10.74	0.79	4.92
	02/24/10	15.66	9.11	10.56	1.45	5.1
	03/10/10	15.66	9.58	10.51	0.93	5.15
	03/17/10	15.66	9.72	10.49	0.77	5.17
	03/24/10	15.66	9.91	10.55	0.64	5.11
	03/31/10	15.66	9.97	10.50	0.53	5.16
	04/07/10	15.66	10.02	10.75	0.73	4.91
	04/14/10	15.66	9.65	10.72	1.07	4.94
	04/21/10	15.66	9.34	10.73	1.39	4.93
	04/28/10	15.66	9.82	10.68	0.86	4.98
	05/05/10	15.66	10.02	10.99	0.97	4.67
	05/12/10	15.66	10.12	11.25	1.13	4.41
	05/19/10	15.66	10.22	11.50	1.28	4.16
	05/26/10	15.66	10.23	11.80	1.57	3.86
	06/02/10	15.66	10.23	11.81	1.58	3.85
	06/09/10	15.66	10.32	12.21	1.89	3.45
	06/17/10	15.66	10.34	12.18	1.84	3.48
	06/23/10	15.66	10.39	12.29	1.90	3.37
	06/30/10	15.66	10.40	12.42	2.02	3.24
	07/07/10	15.66	10.45	12.42	1.97	3.24
	07/14/10	15.66	10.48	12.55	2.07	3.11
	07/21/10	15.66	10.47	12.26	1.79	3.40
	07/28/10	15.66	10.54	12.55	2.01	3.11
	08/04/10	15.66	10.59	12.50	1.91	3.16
	08/11/10	15.66	10.60	12.60	2.00	3.06
	08/18/10	15.66	10.64	12.67	2.03	2.99
	08/25/10	15.66	10.65	12.43	1.78	3.23
	09/01/10	15.66	10.74	12.56	1.82	3.10
	09/07/10	15.66	10.71	12.58	1.87	3.08
	09/14/10	15.66	10.80	12.77	1.97	2.89
	09/22/10	15.66	10.80	12.71	1.91	2.95
	09/29/10	15.66	10.82	12.66	1.84	3.00
	10/06/10	15.66	10.91	13.11	2.20	2.55
	10/20/10	15.66	10.94	12.84	1.90	2.82
	10/27/10	15.66	10.87	12.59	1.72	3.07
	11/03/10	15.66	10.93	12.68	1.75	2.98

**TABLE 3. Free Product Recovery System Groundwater Elevation and Free Product Data
January 1, 2010 Through December 29, 2010
Port of Oakland's Harbor Facilities Complex Site
555 - 651 Maritime Street, Oakland, California**

Recovery Well	Date Measured	Elevation ¹ Top of Casing (feet)	Depth to Product (feet btc)	Depth to Water (feet btc)	Product Thickness (feet)	Groundwater Elevation ¹ (feet)
MW-3 (cont)	11/10/10	15.66	10.80	11.66	0.86	4.00
	11/17/10	15.66	10.82	11.85	1.03	3.81
	11/24/10	15.66	10.51	11.03	0.52	4.63
	12/01/10	15.66	10.65	11.56	0.91	4.10
	12/15/10	15.66	10.13	10.74	0.61	4.92
	12/22/10	15.66	NM	NM	NM	NM
	12/29/10	15.66	9.05 ³	9.05	0.00	6.61
Convault						
	01/06/10	NA	1.99	2.41	0.42	NA
	01/13/10	NA	1.95	2.35	0.40	NA
	01/20/10	NA	1.94	2.34	0.40	NA
	01/27/10	NA	1.90	2.34	0.44	NA
	02/03/10	NA	1.86	2.33	0.47	NA
	02/10/10	NA	1.85	2.33	0.48	NA
	02/17/10	NA	1.81	2.38	0.57	NA
	02/24/10	NA	1.81	2.30	0.49	NA
	03/10/10	NA	1.71	2.23	0.52	NA
	03/17/10	NA	1.70	2.25	0.55	NA
	03/24/10	NA	1.69	2.04	0.35	NA
	03/31/10	NA	NM	NM	NM	NA
	04/07/10	NA	1.68	2.26	0.58	NA
	04/14/10	NA	1.68	2.30	0.62	NA
	04/21/10	NA	1.64	2.28	0.64	NA
	04/28/10	NA	1.65	2.23	0.58	NA
	05/05/10	NA	1.62	2.24	0.62	NA
	05/12/10	NA	1.62	2.23	0.61	NA
	05/19/10	NA	1.61	2.24	0.63	NA
	05/26/10	NA	1.60	2.28	0.68	NA
	06/02/10	NA	1.60	2.42	0.82	NA
	06/09/10	NA	1.59	2.23	0.64	NA
	06/17/10	NA	1.58	2.25	0.67	NA
	06/23/10	NA	1.55	2.24	0.69	NA
	06/30/10	NA	1.46	2.22	0.76	NA
	07/07/10	NA	1.47	2.23	0.76	NA
	07/14/10	NA	1.39 ⁴	2.14	0.75	NA
	07/21/10	NA	1.32	2.15	0.83	NA
	07/28/10	NA	1.24	2.10	0.86	NA
	08/11/10	NA	1.16	2.11	0.95	NA
	08/25/10	NA	1.01	2.08	1.07	NA
	09/01/10	NA	0.96	2.02	1.06	NA
	09/07/10	NA	0.85	2.01	1.16	NA
	09/22/10	NA	empty	empty	0.00	NA

**TABLE 3. Free Product Recovery System Groundwater Elevation and Free Product Data
January 1, 2010 Through December 29, 2010
Port of Oakland's Harbor Facilities Complex Site
555 - 651 Maritime Street, Oakland, California**

Recovery Well	Date Measured	Elevation ¹ Top of Casing (feet)	Depth to Product (feet btc)	Depth to Water (feet btc)	Product Thickness (feet)	Groundwater Elevation ¹ (feet)
Convault	09/29/10	NA	2.40	2.49	0.09	NA
(cont)	10/06/10	NA	2.36	2.50	0.14	NA
	10/20/10	NA	2.29	2.50	0.21	NA
	11/03/10	NA	2.15	2.45	0.30	NA
	11/17/10	NA	2.08	2.42	0.34	NA
	12/01/10	NA	1.96	2.47	0.51	NA
	12/15/10	NA	1.90	2.35	0.45	NA
	12/29/10	NA	1.80	2.33	0.53	NA

Notes:

NP = no product detected with the interface probe

btc = below top of the well casing

NA = not available

NM = not measured

¹ Wells were resurveyed on January 24, 2009. Elevation data is relative to North American Vertical Datum of 1988 (NAVD 88).

² All measurements made before the system ran on given day unless otherwise noted.

³ Product not measureable, but visible evidence of product on interface probe.

⁴ Measured after approximately four gallons of product were removed from MW-3.

Table 1
Groundwater Elevations/Product Removal Data
Port of Oakland
2277 Seventh Street, Oakland, California
(Page 1 of 3)

Well	Date	Top of Casing Elevation ¹ (feet)	Depth to Product (feet)	Depth to Water (feet)	Product Thickness (feet)	Groundwater Elevation ² (feet)	Estimated Product Removed (gallons)	Product Removal Method		
MW-1	3/29/95	14.14	7.50	7.67	0.17	6.61				
	9/6/95		8.68	9.45	0.77	5.31				
	9/28/95		8.74	9.85	1.11	5.18				
	12/27/95		8.51	9.04	0.53	5.52				
	1/8/96		8.67	9.15	0.48	5.37				
	4/4/96		8.25	8.50	0.25	5.84				
	7/10/96		8.70	9.52	0.82	5.28				
	12/3/96		---	---	---	---	0.1	passive skimmer		
	12/13/96		---	---	---	---	0.23	passive skimmer		
	1/6/97		---	---	---	---	0.08	passive skimmer		
	MW-2		5/27/94	14.36		8.01		6.35		
3/29/95			7.47			6.89				
9/6/95			9.04			5.32				
9/28/95			7.47			6.89				
12/27/95			8.95			5.41				
1/8/96			8.95			5.41				
4/4/96			8.46			5.90				
7/10/96			9.03			5.33				
12/3/96			9.54			4.82				
MW-3		3/29/95	14.22		6.66	9.59	2.93	6.97		
		9/6/95			8.48	13.70	5.22	4.70		
	9/28/95	7.80		13.60	5.80	5.26				
	12/27/95	8.01		12.71	4.70	5.27				
	1/8/96	8.16		13.10	4.94	5.07				
	4/4/96	7.10		11.50	4.40	6.24				
	7/10/96	7.94		13.28	5.34	5.21				
	10/3/96	8.62		14.45	5.83	4.43	25	peristaltic pump		
	10/10/96	8.77		14.46	5.69	4.31	25	peristaltic pump		
	10/18/96	8.85		14.54	5.69	4.23	25	peristaltic pump		
	10/25/96	8.74		14.43	5.69	4.34	20	peristaltic pump		
	11/1/96	8.85		14.41	5.56	4.26	20	peristaltic pump		
	11/8/96	8.82		14.50	5.68	4.26	25	peristaltic pump		
	12/3/96	---		---	---	---	13	active skimmer		
	12/13/96	---		---	---	---	---	active skimmer		
1/6/97	---	---	---	---	750	active skimmer				

Table 1 Continued
Groundwater Elevations/Product Removal Data
Port of Oakland
2277 Seventh Street, Oakland, California
(Page 2 of 3)

Well	Date	Top of Casing Elevation ¹ (feet)	Depth to Product (feet)	Depth to Water (feet)	Product Thickness (feet)	Groundwater Elevation ² (feet)	Estimated Product Removed (gallons)	Product Removal Method
MW-4	3/29/95	13.15		9.59		3.56		
	9/6/95			8.48		4.67		
	9/11/95			9.59		3.56		
	9/28/95			9.59		3.56		
	12/27/95			8.39		4.76		
	1/8/96			8.42		4.73		
	4/4/96			8.19		4.96		
	7/10/96			8.56		4.59		
12/3/96		8.69		4.46				
MW-5	9/6/95	13.49		6.90		6.59		
	9/11/95			9.59		3.90		
	9/28/95			9.59		3.90		
	12/27/95			7.17		6.32		
	4/4/96			6.44		7.05		
	7/10/96			6.79		6.70		
	12/3/96			7.06		6.43		
MW-6	9/6/95	14.00	4.47	7.40	2.93	8.94		
	9/28/95		6.66	9.59	2.93	6.75		
	12/27/96			8.07		5.93		
	1/8/96			7.70		6.30		
	4/4/96			7.70		6.30		
	7/10/96			7.55		6.45		
	12/3/96		---	6.41	---	7.59		
MW-7	9/6/95	14.35		9.10		5.25		
	9/28/95			9.74		4.61		
	12/27/96			9.06		5.29		
	1/8/96			9.06		5.29		
	4/4/96			8.57		5.78		
	7/10/96			9.11		5.24		
	12/3/96			9.62		4.73		

Table 1 Continued
Groundwater Elevations/Product Removal Data
Port of Oakland
2277 Seventh Street, Oakland, California
(Page 3 of 3)

Well	Date	Top of Casing Elevation ¹ (feet)	Depth to Product (feet)	Depth to Water (feet)	Product Thickness (feet)	Groundwater Elevation ² (feet)	Estimated Product Removed (gallons)	Product Removal Method
MW-8	9/6/95	12.94		7.84		5.10		
	9/28/95		8.79	8.91	0.12	4.13		
	12/27/96		8.30	8.61	0.31	4.58		
	1/8/96		8.35	8.80	0.45	4.50		
	4/4/96		8.32	8.37	0.05	4.61		
	7/10/96		9.41	9.44	0.03	3.52		
	12/3/96		---	---	---	---	0.003	passive skimmer
	12/13/96		---	---	---	---	0.007	passive skimmer
	1/6/97		---	---	---	---	0.007	passive skimmer

Notes:

¹ Top of Casing (TOC) Elevations from Groundwater Monitoring and Sampling Report by Alisto Engineering Group, dated September 12, 1996. TOC elevations surveyed to nearest 0.01 foot relative to mean lower low water (Port of Oakland Datum: 3.2 feet below mean sea level).

--- = not measured/not estimated

² Groundwater Elevation corrected for the presence of floating product according to the formula:
 $CDTW = DTW - (0.80 \times PT)$, where CDTW is the corrected depth to groundwater, DTW is the measured depth to groundwater, 0.80 is the density correction factor for diesel, and PT is the measured thickness of floating product.

Measurements on 12/3/96, 12/13/96, and 1/6/97 by U&A; all other measurements listed from Alisto Engineering Group (1996).

From 3Q97 GWMR

Table 1
Groundwater Elevations/Product Removal Data
Port of Oakland
2277 Seventh Street, Oakland, California
(Page 1 of 4)

Well	Date	Top of Casing Elevation ¹ (feet)	Depth to Product (feet)	Depth to Water (feet)	Product Thickness (feet)	Groundwater Elevation ² (feet)	Estimated Product Removed (gallons)	Product Removal Method
MW-1	3/29/95	14.14	7.50	7.67	0.17	6.61		
	9/6/95		8.68	9.45	0.77	5.31		
	9/28/95		8.74	9.85	1.11	5.18		
	12/27/95		8.51	9.04	0.53	5.52		
	1/8/96		8.67	9.15	0.48	5.37		
	4/4/96		8.25	8.50	0.25	5.84		
	7/10/96		8.70	9.52	0.82	5.28		
	12/3/96		---	---	---	---	0.1	passive skimmer
	12/13/96		---	---	---	---	0.23	passive skimmer
	1/6/97		---	---	---	---	0.08	passive skimmer
	3/28/97		---	---	---	---	0.002	passive skimmer
	6/13/97		---	---	---	---	0.23	passive skimmer
	9/18/97		---	---	---	---	0.23	passive skimmer
MW-2	5/27/94	14.36		8.01		6.35		
	3/29/95			7.47		6.89		
	9/6/95			9.04		5.32		
	9/28/95			7.47		6.89		
	12/27/95			8.95		5.41		
	1/8/96			8.95		5.41		
	4/4/96			8.46		5.90		
	7/10/96			9.03		5.33		
	12/3/96			9.54		4.82		
	3/28/97			7.89		6.47		
	6/13/97			9.17		5.19		
9/18/97		9.51		4.85				

Table 1 Continued
Groundwater Elevations/Product Removal Data
Port of Oakland
2277 Seventh Street, Oakland, California
(Page 2 of 4)

Well	Date	Top of Casing Elevation ¹ (feet)	Depth to Product (feet)	Depth to Water (feet)	Product Thickness (feet)	Groundwater Elevation ² (feet)	Estimated Product Removed (gallons)	Product Removal Method
MW-3	3/29/95	14.22	6.66	9.59	2.93	6.97		
	9/6/95		8.48	13.70	5.22	4.70		
	9/28/95		7.80	13.60	5.80	5.26		
	12/27/95		8.01	12.71	4.70	5.27		
	1/8/96		8.16	13.10	4.94	5.07		
	4/4/96		7.10	11.50	4.40	6.24		
	7/10/96		7.94	13.28	5.34	5.21		
	10/3/96		8.62	14.45	5.83	4.43	25	peristaltic pump
	10/10/96		8.77	14.46	5.69	4.31	25	peristaltic pump
	10/18/96		8.85	14.54	5.69	4.23	25	peristaltic pump
	10/25/96		8.74	14.43	5.69	4.34	20	peristaltic pump
	11/1/96		8.85	14.41	5.56	4.26	20	peristaltic pump
	11/8/96		8.82	14.50	5.68	4.26	25	peristaltic pump
	12/3/96		---	---	---	---	13	active skimmer
	12/13/96		---	---	---	---	---	active skimmer
	1/6/97		---	---	---	---	750	active skimmer
	2/19/97		---	---	---	---	425	active skimmer
	5/1/97		---	---	---	---	350	active skimmer
	6/13/97		---	---	---	---	50	active skimmer
	10/23/97		---	---	---	---	350	active skimmer
MW-4	3/29/95	13.15		9.59		3.56		
	9/6/95			8.48		4.67		
	9/11/95			9.59		3.56		
	9/28/95			9.59		3.56		
	12/27/95			8.39		4.76		
	1/8/96			8.42		4.73		
	4/4/96			8.19		4.96		
	7/10/96			8.56		4.59		
	12/3/96			8.69		4.46		
	3/28/97			7.40		5.75		
	6/13/97			8.53		4.62		
9/18/97		8.62		4.53				

Table 1 Continued
Groundwater Elevations/Product Removal Data
Port of Oakland
2277 Seventh Street, Oakland, California
(Page 3 of 4)

Well	Date	Top of Casing Elevation (feet)	Depth to Product (feet)	Depth to Water (feet)	Product Thickness (feet)	Groundwater Elevation ² (feet)	Estimated Product Removed (gallons)	Product Removal Method
MW-5	9/6/95	13.49		6.90		6.59		
	9/11/95			9.59		3.90		
	9/28/95			9.59		3.90		
	12/27/95			7.17		6.32		
	4/4/96			6.44		7.05		
	7/10/96			6.79		6.70		
	12/3/96			7.06		6.43		
	3/28/97			6.45		7.04		
	6/13/97			6.58		6.91		
9/18/97		6.89		6.60				
MW-6	9/6/95	14.00	4.47	7.40	2.93	8.94		
	9/28/95		6.66	9.59	2.93	6.75		
	12/27/96			8.07		5.93		
	1/8/96			7.70		6.30		
	4/4/96			7.70		6.30		
	7/10/96			7.55		6.45		
	12/3/96		---	6.41	---	7.59		
	3/28/97		---	---	---	---	0.0005	passive skimmer
	6/13/97		---	---	---	---	0	passive skimmer
	9/18/97		---	---	---	---	0	passive skimmer

Table 1 Continued
Groundwater Elevations/Product Removal Data
Port of Oakland
2277 Seventh Street, Oakland, California
(Page 4 of 4)

Well	Date	Top of Casing Elevation ¹ (feet)	Depth to Product (feet)	Depth to Water (feet)	Product Thickness (feet)	Groundwater Elevation ² (feet)	Estimated Product Removed (gallons)	Product Removal Method
MW-7	9/6/95	14.35		9.10		5.25		
	9/28/95			9.74		4.61		
	12/27/96			9.06		5.29		
	1/8/96			9.06		5.29		
	4/4/96			8.57		5.78		
	7/10/96			9.11		5.24		
	12/3/96			9.62		4.73		
	3/28/97			8.06		6.29		
	6/13/97			8.28		6.07		
	9/18/97			9.65		4.70		
MW-8	9/6/95	12.94		7.84		5.10		
	9/28/95		8.79	8.91	0.12	4.13		
	12/27/96		8.30	8.61	0.31	4.58		
	1/8/96		8.35	8.80	0.45	4.50		
	4/4/96		8.32	8.37	0.05	4.61		
	7/10/96		9.41	9.44	0.03	3.52		
	12/3/96		---	---	---	---	0.003	passive skimmer
	12/13/96		---	---	---	---	0.007	passive skimmer
	1/6/97		---	---	---	---	0.007	passive skimmer
	3/28/97		---	---	---	---	---	---
	6/13/97		9.04	9.05	0.01	3.90	---	---
	9/18/97		9.22	9.60	0.38	3.64	---	---

Notes:

¹ Top of Casing (TOC) Elevations from Groundwater Monitoring and Sampling Report by Alisto Engineering Group, dated September 12, 1996. TOC elevations surveyed to nearest 0.01 foot relative to mean lower low water (Port of Oakland Datum; 3.2 feet below mean sea level).

--- = not measured/not estimated

² Groundwater Elevation corrected for the presence of floating product according to the formula:
 $CDTW = DTW - (0.80 \times PT)$, where CDTW is the corrected depth to groundwater, DTW is the measured depth to groundwater, 0.80 is the density correction factor for diesel, and PT is the measured thickness of floating product.

Measurements on and since 12/3/96 by U&A; all other measurements listed from Alisto Engineering Group (1996).

**Table 2. Product Removal and Product Thickness Data
Port of Oakland
2277 7th Street, Oakland California**

Well ID	Elevation of Top of Casing ¹ (feet)	Date Of Monitoring	Depth to Free Product (feet)	Depth to Water (feet)	Product Thickness (feet)	Estimated Product Removed (gallons)	Product Removal Method ²
MW-1	14.14	12/31/97	-	-	-	0.2	passive skimmer
		01/29/98	-	-	-	0.2	passive skimmer
		03/02/98	-	-	-	0.018	passive skimmer
		05/11/98	-	-	-	0.02	passive skimmer
		06/15/98	-	-	-	0.2	passive skimmer
		11/06/98	9.34	10.3	0.96	1.2	passive skimmer
		01/07/99	-	-	-	0.2	passive skimmer
		02/11/99	-	-	-	0.2	passive skimmer
		03/12/99	-	-	-	0.2	passive skimmer
		03/19/99	NM	8.45	>0.01	0.07	passive skimmer
		04/14/99	-	-	-	0.2	passive skimmer
		05/11/99	-	-	-	0.2	passive skimmer
		06/24/99	8.88	9.63	0.8	0.2	passive skimmer
		07/15/99	-	-	-	0.2	passive skimmer
		07/16/99	-	-	-	0.2	passive skimmer
		08/27/99	-	-	-	0.2	passive skimmer
09/28/99	-	-	0.65	0.2	passive skimmer		
10/05/99	-	-	-	0.2	passive skimmer		
11/12/99	9.38	10.27	0.89	0.2	passive skimmer		
12/21/99	-	-	-	0.2	passive skimmer		
MW-3	14.22	12/31/97	-	-	-	30	active skimmer
		01/29/98	-	-	-	10	active skimmer
		04/13/98	-	-	-	240	active skimmer
		05/11/98	-	-	-	1,545	active skimmer
		06/15/98	-	-	-	1,950	active skimmer
		11/06/98	8.84	9.94	1.1	500	active skimmer
		01/05/99	-	-	-	275 ³	active skimmer
		01/14/99	-	-	-	400 ³	active skimmer
		02/03/99	-	-	-	400 ³	active skimmer
		02/26/99	-	-	-	570 ³	active skimmer
		03/19/99	7.52	8.05	0.5	211	active skimmer
		06/16/99	-	-	-	310	active skimmer
		06/24/99	8.38	8.56	0.2	-	active skimmer
		07/14/99	-	-	-	50 ³	active skimmer
		09/28/99	-	-	0.2	-	active skimmer
10/29/99	-	-	-	125 ³	active skimmer		
11/12/99	9.14	9.23	0.09	-	active skimmer		
MW-6	14.00	13/31/97	-	-	-	0.0014	passive skimmer
		01/29/98	-	-	-	0.0014	passive skimmer
		03/02/98	-	-	-	0.0014	passive skimmer
		11/06/98	NM	9.62	>0.01	0.0	passive skimmer
		03/19/99	NM	7.37	>0.01	0.0	passive skimmer
MW-8 ¹	12.94	12/31/97	8.49	8.82	0.33	4.38	-
		11/06/98	9.25	10.3	1.1	3.48	-

- Data prior to November 6, 1998 taken from *Groundwater Monitoring, Sampling and Product Removal System O&M Report* dated July 21, 1998, by Innovative Technical Solutions, Inc.

- Data prior to November 6, 1998 taken from *Groundwater Monitoring, Sampling and Product*

- Product removal volumes from 11/6/98 on represent total product removed during that reporting period.

¹ Free product in well is too viscous to allow product thickness or groundwater level measurements.

² Product removal totals for MW-3 are estimated from documentation of product removal from the treatment system performed by Performance Excavators, Inc.

NM - Well checked for free product but was not able to detect a measurable amount in the well.

Greyed areas indicates data from this reporting period.

**TABLE 1. Historical Groundwater Elevation and Free Product Data
Port of Oakland's Harbor Facilities Complex Site
555 - 651 Maritime Street, Oakland, California**

Monitoring Well	Date Measured	Elevation ¹ Top of Casing (feet)	Depth to Product (feet btc)	Depth to Water (feet btc)	Product Thickness (feet)	Groundwater Elevation ¹ (feet)
MW-1						
	04/18/00	13.65	NM	8.21	0.0	5.44
	05/22/00	13.65	NM	8.51	0.0	5.14
	07/10/01	13.65	8.8	10.00	1.20	3.65
	12/12/01	13.65	NM	NA	NA	NA
	03/08/02	13.65	NM	NA	NA	NA
	06/13/02	13.65	8.70	10.00	1.30	3.65
	09/26/02	13.65	8.60	9.50	0.90	4.15
	03/17/03	13.65	7.61	8.88	1.27	4.77
	06/18/03	13.65	8.20	9.44	1.24	4.21
	09/03/03	13.65	8.50	9.40	0.90	4.25
	11/26/03	13.65	8.85	9.25	0.40	4.40
	03/05/04	13.65	6.76	7.07	0.31	6.58
	06/02/04	13.65	8.26	8.71	0.45	4.94
	09/03/04	13.65	8.70	9.11	0.41	4.54
	12/16/04	13.65	7.75	7.92	0.17	5.73
	03/29/05	13.65	6.21	6.38	0.17	7.27
	06/14/05	13.65	7.41	7.61	0.20	6.04
	08/10/05	13.65	8.05	8.55	0.50	5.10
	09/29/05	13.65	8.28	8.95	0.67	4.70
	12/21/05	13.65	5.70	5.90	0.20	7.75
	03/24/06	13.65	5.98	6.27	0.29	7.38
	07/28/06	13.65	7.88	8.35	0.47	5.30
	11/29/06	NA	10.58	10.81	0.23	NA
	06/01/07	15.80	11.11	11.45	0.34	4.35
	11/14/07	15.80	10.87	10.93	0.06	4.87
	06/05/08	15.80	11.36	11.46	0.10	4.34
	12/18/08	15.80	10.82	10.89	0.07	4.91
	03/04/09	15.80	9.38	9.52	0.14	6.28
	04/01/09	15.80	10.65	10.67	0.02	5.13
	06/17/09	15.80	11.21	11.28	0.07	4.52
	12/08/09	15.80	NP	10.79	0.0	5.01
	06/17/10	15.80	10.79 ⁴	10.79	0.0	5.01
	12/14/10	15.80	9.42 ⁴	9.42	0.0	6.38
	06/07/11	15.80	NP	10.77	0.0	5.03
	06/21/11	15.80	NP	10.37	0.0	5.43
	09/26/11	15.80	11.23 ⁴	11.23	0.0	4.57
	12/05/11	15.80	11.15 ⁴	11.15	0.0	4.65
MW-2						
	12/31/97	13.87	NP	8.73	0.0	5.14
	04/13/98	13.87	NP	7.72	0.0	6.15
	11/06/98	13.87	NP	9.43	0.0	4.44
	03/19/99	13.87	NP	8.21	0.0	5.66
	06/24/99	13.87	NP	8.91	0.0	4.96
	09/28/99	13.87	NP	9.42	0.0	4.45
	11/12/99	13.87	NP	9.63	0.0	4.24
	02/11/00	13.87	NP	8.54	0.0	5.33
	05/22/00	13.87	NP	8.10	0.0	5.77
	09/06/00	13.87	NP	8.79	0.0	5.08
	12/19/00	13.87	NP	9.19	0.0	4.68
	02/21/01	13.87	NP	7.99	0.0	5.88
	04/03/01	13.87	NP	8.23	0.0	5.64
	07/10/01	13.87	NP	8.70	0.0	5.17
	12/12/01	13.87	NP	8.16	0.0	5.71
	01/22/02	13.87	NP	7.64	0.0	6.23
	03/08/02	13.87	NP	8.31	0.0	5.56
	06/13/02	13.87	NP	8.64	0.0	5.23

**TABLE 1. Historical Groundwater Elevation and Free Product Data
Port of Oakland's Harbor Facilities Complex Site
555 - 651 Maritime Street, Oakland, California**

Monitoring Well	Date Measured	Elevation ¹ Top of Casing (feet)	Depth to Product (feet btc)	Depth to Water (feet btc)	Product Thickness (feet)	Groundwater Elevation ¹ (feet)
MW-2 (cont)	09/26/02	13.87	NP	8.95	0.0	4.92
	12/12/02	13.87	NP	9.17	0.0	4.70
	03/17/03	13.87	NP	7.77	0.0	6.10
	06/18/03	13.87	NP	8.44	0.0	5.43
	09/03/03	13.87	NP	8.98	0.0	4.89
	11/26/03	16.72	NP	12.01	0.0	4.71
	03/05/04	16.72	NP	9.75	0.0	6.97
	06/02/04	16.72	NP	11.22	0.0	5.50
	09/03/04	16.72	NP	11.62	0.0	5.10
	12/16/04	16.72	NP	10.80	0.0	5.92
	03/29/05	16.72	NP	9.67	0.0	7.05
	06/14/05	16.72	NP	10.68	0.0	6.04
	08/10/05	16.72	NP	11.05	0.0	5.67
	09/29/05	16.72	NP	11.32	0.0	5.40
	12/21/05	16.47	NP	9.57	0.0	6.90
	03/24/06	16.47	NP	9.55	0.0	6.92
	07/28/06	16.47	NP	10.85	0.0	5.62
	11/29/06	NA	NP	11.69	0.0	NA
	06/01/07	16.43	NP	11.72	0.0	4.71
	11/14/07	16.43	NP	12.28	0.0	4.15
	06/05/08	16.43	NP	12.01	0.0	4.42
	12/18/08	16.43	NP	12.20	0.0	4.23
	03/04/09	16.43	NP	10.19	0.0	6.24
	04/01/09	16.43	NP	11.34	0.0	5.09
	06/17/09	16.43	NP	11.90	0.0	4.53
	12/09/09	16.43	NP	12.13	0.0	4.30
	06/16/10	16.43	NP	11.57	0.0	4.86
	12/14/10	16.43	NP	11.04	0.0	5.39
	06/07/11	16.43	NP	10.70	0.0	5.73
	06/21/11	16.43	NP	11.18	0.0	5.25
	09/26/11	16.43	NP	11.87	0.0	4.56
	12/05/11	16.43	NP	11.95	0.0	4.48
MW-3						
	11/06/98	13.73	8.84	9.94	1.10	NC
	03/19/99	13.73	7.52	8.05	0.53	NC
	06/24/99	13.73	8.38	8.56	0.18	NC
	11/12/99	13.73	9.14	9.23	0.09	NC
	02/11/00	13.73	7.97	8.37	0.40	NC
	03/01/00	13.73	6.59	7.24	0.65	NC
	03/21/00	13.73	6.50	6.56	0.06	NC
	05/22/00	13.73	7.51	8.05	0.54	NC
	06/26/00	13.73	7.82	8.20	0.38	NC
	07/25/00	13.73	7.90	8.92	1.02	NC
	08/31/00	13.73	8.15	9.50	1.35	NC
	09/06/00	13.73	8.21	9.42	1.21	NC
	09/21/00	13.73	8.30	8.88	0.58	NC
	12/19/00	13.73	8.60	9.65	1.05	NC
	02/22/01	13.73	6.36	8.15	1.79	NC
	04/03/01	13.73	7.48	8.88	1.40	NC
	04/23/01	13.73	7.85	9.10	1.25	NC
	05/30/01	13.73	7.75	9.10	1.35	NC
	07/10/01	13.73	8.10	9.60	1.50	NC
	03/08/02	13.73	7.80	8.00	0.20	NC

**TABLE 1. Historical Groundwater Elevation and Free Product Data
Port of Oakland's Harbor Facilities Complex Site
555 - 651 Maritime Street, Oakland, California**

Monitoring Well	Date Measured	Elevation ¹ Top of Casing (feet)	Depth to Product (feet btc)	Depth to Water (feet btc)	Product Thickness (feet)	Groundwater Elevation ¹ (feet)
MW-3 (cont)	04/03/02	13.73	7.60	7.70	0.10	NC
	04/23/02	13.73	7.90	8.40	0.50	NC
	04/25/02	13.73	7.90	8.80	0.90	NC
	05/10/02	13.73	8.10	8.20	0.10	NC
	05/24/02	13.73	8.05	8.10	0.05	NC
	06/13/02	13.73	8.10	8.70	0.60	NC
	07/05/02	13.73	8.10	8.95	0.85	NC
	07/19/02	13.73	8.10	8.90	0.80	NC
	07/30/02	13.73	8.10	8.90	0.80	NC
	08/14/02	13.73	8.10	8.90	0.80	NC
	09/13/02	13.73	8.30	9.30	1.00	NC
	09/26/02	13.73	8.30	9.00	0.70	NC
	10/14/02	13.73	8.60	9.50	0.90	NC
	11/04/02	13.73	8.75	9.99	1.24	NC
	11/21/02	13.73	8.59	11.29	2.70	NC
	12/06/02	13.73	8.56	9.30	0.74	NC
	12/18/02	13.73	7.35	8.43	1.08	NC
	12/30/02	13.73	6.50	7.15	0.65	NC
	01/02/03	13.73	6.20	6.20	0.00	7.53
	01/03/03	13.73	6.21	6.21	0.00	7.52
	01/14/03	13.73	6.20	6.21	0.01	7.52
	01/30/03	13.73	6.81	6.85	0.04	6.88
	02/18/03	13.73	7.09	7.15	0.06	NC
	02/26/03	13.73	7.04	7.11	0.07	NC
	03/13/03	13.73	7.22	8.11	0.89	NC
	03/17/03	13.73	7.15	7.50	0.35	NC
	04/16/03	13.73	7.27	8.25	0.98	NC
	06/18/03	13.73	7.78	9.00	1.22	NC
	09/03/03	13.73	8.31	9.96	1.65	NC
	11/26/03	15.69	10.79	12.85	2.06	NC
	03/05/04	15.69	8.39	9.85	1.46	NC
	06/02/04	15.69	10.03	11.35	1.32	NC
	09/03/04	15.69	10.46	12.06	1.60	NC
	12/16/04	15.69	9.41	10.38	0.97	NC
	03/29/05	15.69	8.17	9.01	0.84	NC
	06/14/05	15.69	9.59	10.55	0.96	NC
	08/10/05	15.69	9.91	11.15	1.24	NC
	09/29/05	15.69	10.21	11.61	1.40	NC
	12/21/05	15.69	8.21	8.28	0.07	NC
	03/24/06	15.69	8.20	8.82	0.62	NC
	07/28/06	15.69	9.81	9.83	0.02	NC
	11/29/06	NA	10.72	11.70	0.98	NA
	06/01/07	15.66	10.77	11.46	0.69	NC
	11/14/07	15.66	10.98	12.19	1.21	NC
	06/05/08	15.66	10.51	11.96	1.45	NC
	12/18/08	15.66	10.78	12.00	1.22	3.66
	03/04/09	15.66	9.31	9.93	0.62	5.73
	04/01/09	15.66	10.38	11.10	0.72	4.56
	06/17/09	15.66	10.79	12.30	1.51	3.36
	12/08/09	15.66	11.05	12.81	1.76	2.85
	06/17/10	15.66	10.39	12.29	1.90	3.37
	12/15/10	15.66	10.13	10.74	0.61	4.92

**TABLE 1. Historical Groundwater Elevation and Free Product Data
Port of Oakland's Harbor Facilities Complex Site
555 - 651 Maritime Street, Oakland, California**

Monitoring Well	Date Measured	Elevation ¹ Top of Casing (feet)	Depth to Product (feet btc)	Depth to Water (feet btc)	Product Thickness (feet)	Groundwater Elevation ¹ (feet)
MW-3 (cont)	06/07/11	15.66	9.91	10.95	1.04	4.71
	06/21/11	15.66	10.74	11.20	0.46	4.46
	09/26/11	15.66	10.71	12.55	1.84	3.11
	12/05/11	15.66	10.83	12.20	1.37	3.46
MW-4						
	12/31/97	12.66	NP	7.09	0.0	5.57
	04/13/98	12.66	NP	7.71	0.0	4.95
	11/06/98	12.66	NP	8.69	0.0	3.97
	03/19/99	12.66	NP	8.00	0.0	4.66
	06/24/99	12.66	NP	8.45	0.0	4.21
	09/28/99	12.66	NP	8.73	0.0	3.93
	11/12/99	12.66	NP	8.83	0.0	3.83
	02/11/00	12.66	NP	7.71	0.0	4.95
	05/22/00	12.66	NP	8.09	0.0	4.57
	09/06/00	12.66	NP	8.32	0.0	4.34
	12/19/00	12.66	NP	8.47	0.0	4.19
	02/21/01	12.66	NP	7.51	0.0	5.15
	04/03/01	12.66	NP	8.13	0.0	4.53
	07/10/01	12.66	NP	8.12	0.0	4.54
	12/12/01	12.66	NP	7.65	0.0	5.01
	01/22/02	12.66	NP	7.60	0.0	5.06
	03/08/02	12.66	NP	7.96	0.0	4.70
	06/13/02	12.66	NP	8.20	0.0	4.46
	09/26/02	12.66	NP	8.21	0.0	4.45
	12/12/02	12.66	NP	8.38	0.0	4.28
	03/17/03	12.66	NP	7.72	0.0	4.94
	06/18/03	12.66	NP	8.02	0.0	4.64
	09/03/03	12.66	NP	8.29	0.0	4.37
	11/26/03	12.66	NP	8.69	0.0	3.97
	03/05/04	12.66	NP	7.45	0.0	5.21
	06/02/04	12.66	NP	8.25	0.0	4.41
	09/03/04	12.66	NP	8.31	0.0	4.35
	12/16/04	12.66	NP	7.96	0.0	4.70
	03/29/05	12.66	NP	7.11	0.0	5.55
	06/14/05	12.66	NP	7.90	0.0	4.76
	08/10/05	12.66	NP	7.86	0.0	4.80
	09/29/05	12.66	NP	8.00	0.0	4.66
	12/21/05	12.66	NP	7.30	0.0	5.36
	03/24/06	12.66	NP	7.05	0.0	5.61
	07/28/06	12.66	NP	7.92	0.0	4.74
	11/29/06	NA	NP	11.63	0.0	NA
	06/01/07	15.91	NP	11.82	0.0	4.09
	11/14/07	15.91	NP	11.88	0.0	4.03
	06/05/08	15.91	NP	11.67	0.0	4.24
	12/18/08	15.91	NP	11.20	0.0	4.71
	03/04/09	15.91	NP	10.93	0.0	4.98
	04/01/09	15.91	NP	11.63	0.0	4.28
	06/17/09	15.91	NP	11.88	0.0	4.03
	12/08/09	15.91	NP	12.03	0.0	3.88
	06/16/10	15.91	NP	11.75	0.0	4.16
	12/14/10	15.91	NP	11.62	0.0	4.29
	06/07/11	15.91	NP	11.80	0.0	4.11

**TABLE 1. Historical Groundwater Elevation and Free Product Data
Port of Oakland's Harbor Facilities Complex Site
555 - 651 Maritime Street, Oakland, California**

Monitoring Well	Date Measured	Elevation ¹ Top of Casing (feet)	Depth to Product (feet btc)	Depth to Water (feet btc)	Product Thickness (feet)	Groundwater Elevation ¹ (feet)
MW-4 (cont)	06/21/11	15.91	NP	11.42	0.0	4.49
	09/26/11	15.91	NP	11.83	0.0	4.08
	12/05/11	15.91	NP	12.03	0.0	3.88
MW-5						
	12/31/97	13.00	NP	6.38	0.0	6.62
	04/13/98	13.00	NP	5.56	0.0	7.44
	11/06/98	13.00	NP	6.59	0.0	6.41
	03/19/99	13.00	NP	6.20	0.0	6.80
	06/24/99	13.00	NP	6.73	0.0	6.27
	09/28/99	13.00	NP	6.91	0.0	6.09
	11/12/99	13.00	NP	7.06	0.0	5.94
	02/11/00	13.00	NP	7.00	0.0	6.00
	05/22/00	13.00	NP	6.21	0.0	6.79
	09/06/00	13.00	NP	6.56	0.0	6.44
	12/19/00	13.00	NP	6.68	0.0	6.32
	02/21/01	13.00	NP	6.08	0.0	6.92
	04/03/01	13.00	NP	6.38	0.0	6.62
	07/10/01	13.00	NP	6.58	0.0	6.42
	12/12/01	13.00	NP	6.40	0.0	6.60
	01/22/02	13.00	NP	6.10	0.0	6.90
	03/08/02	13.00	NP	6.10	0.0	6.90
	06/13/02	13.00	NP	6.31	0.0	6.69
	09/26/02	13.00	NP	6.60	0.0	6.40
	12/12/02	13.00	NP	6.75	0.0	6.25
	03/17/03	13.00	NP	5.73	0.0	7.27
	06/18/03	13.00	NP	6.10	0.0	6.90
	09/03/03	13.00	NP	6.50	0.0	6.50
	11/26/03	13.00	NP	6.70	0.0	6.30
	03/05/04	13.00	NP	5.70	0.0	7.30
	06/02/04	13.00	NP	6.27	0.0	6.73
	09/03/04	13.00	NP	6.61	0.0	6.39
	12/16/04	13.00	NP	6.02	0.0	6.98
	03/29/05	13.00	NP	5.25	0.0	7.75
	06/14/05	13.00	NP	5.82	0.0	7.18
	08/10/05	13.00	NP	6.00	0.0	7.00
	09/29/05	13.00	NP	6.26	0.0	6.74
	12/21/05	13.00	NP	5.91	0.0	7.09
	03/24/06	13.00	NP	NA ²	NA ²	NA
	07/28/06	13.00	NP	6.08	0.0	6.92
	11/29/06	NA	NP	9.39	0.0	NA
	06/01/07	15.39	NP	10.60	0.0	4.79
	11/14/07	15.39	NP	9.77	0.0	5.62
	06/05/08	15.39	NP	9.74	0.0	5.65
	12/18/08	15.39	NP	9.80	0.0	5.59
	03/04/09	15.39	NP	8.78	0.0	6.61
	04/01/09	15.39	NP	9.16	0.0	6.23
	06/17/09	15.39	NP	9.51	0.0	5.88
	12/08/09	15.39	NP	9.52	0.0	5.87
	06/16/10	15.39	NP	9.31	0.0	6.08
	12/14/10	15.39	NP	9.31	0.0	6.08
	06/07/11	15.39	NP	9.06	0.0	6.33
	06/21/11	15.39	NP	9.06	0.0	6.33
	09/26/11	15.39	NP	9.30	0.0	6.09
	12/05/11	15.39	NP	9.31	0.0	6.08

**TABLE 1. Historical Groundwater Elevation and Free Product Data
Port of Oakland's Harbor Facilities Complex Site
555 - 651 Maritime Street, Oakland, California**

Monitoring Well	Date Measured	Elevation ¹ Top of Casing (feet)	Depth to Product (feet btc)	Depth to Water (feet btc)	Product Thickness (feet)	Groundwater Elevation ¹ (feet)
MW-6						
	06/24/99	13.51	NP	8.61	0.0	4.90
	09/28/99	13.51	NP	9.26	0.0	4.25
	11/12/99	13.51	NP	8.01	0.0	5.50
	02/11/00	13.51	NP	7.20	0.0	6.31
	05/22/00	13.51	NP	7.13	0.0	6.38
	09/06/00	13.51	NP	7.12	0.0	6.39
	12/19/00	13.51	NP	7.57	0.0	5.94
	02/21/01	13.51	NP	7.50	0.0	6.01
	04/03/01	13.51	NP	6.88	0.0	6.63
	07/10/01	13.51	NP	7.15	0.0	6.36
	12/12/01	13.51	NP	9.50	0.0	4.01
	01/22/02	13.51	NP	6.69	0.0	6.82
	03/08/02	13.51	NP	6.98	0.0	6.53
	06/13/02	13.51	NP	7.45	0.0	6.06
	09/26/02	13.51	NP	7.95	0.0	5.56
	12/12/02	13.51	NP	7.71	0.0	5.80
	12/18/02	Monitoring well was destroyed				
MW-7						
	12/31/97	13.86	NP	8.88	0.0	4.98
	04/13/98	13.86	NP	7.86	0.0	6.00
	11/06/98	13.86	NP	9.55	0.0	4.31
	03/19/99	13.86	NP	8.41	0.0	5.45
	06/24/99	13.86	NP	9.08	0.0	4.78
	09/28/99	13.86	NP	9.60	0.0	4.26
	11/12/99	13.86	NP	9.77	0.0	4.09
	02/11/00	13.86	NP	8.67	0.0	5.19
	05/22/00	13.86	NP	8.43	0.0	5.43
	09/06/00	13.86	NP	8.88	0.0	4.98
	12/19/00	13.86	NP	9.21	0.0	4.65
	02/21/01	13.86	NP	8.13	0.0	5.73
	04/03/01	13.86	NP	8.45	0.0	5.41
	07/10/01	13.86	NP	8.87	0.0	4.99
	12/12/01	13.86	NP	8.39	0.0	5.47
	01/22/02	13.86	NP	7.99	0.0	5.87
	03/08/02	13.86	NP	8.51	0.0	5.35
	06/13/02	13.86	NP	8.90	0.0	4.96
	09/26/02	13.86	NP	9.00	0.0	4.86
	12/12/02	13.86	NP	9.28	0.0	4.58
	12/18/02	Monitoring well was destroyed				
MW-8 ³						
	12/31/97	12.45	8.49	8.82	0.33	NC
	11/06/98	12.45	9.25	10.30	1.05	NC
	11/21/98	Monitoring well was destroyed and replaced with well MW-8A				

**TABLE 1. Historical Groundwater Elevation and Free Product Data
Port of Oakland's Harbor Facilities Complex Site
555 - 651 Maritime Street, Oakland, California**

Monitoring Well	Date Measured	Elevation ¹ Top of Casing (feet)	Depth to Product (feet btc)	Depth to Water (feet btc)	Product Thickness (feet)	Groundwater Elevation ¹ (feet)
MW-8A						
	12/12/01	12.45	NP	7.20	0.0	NA
	01/22/02	12.45	NP	7.20	0.0	5.25
	03/08/02	12.45	NP	7.70	0.0	4.75
	06/13/02	12.45	NP	7.72	0.0	4.73
	09/26/02	12.45	NP	7.91	0.0	4.54
	12/12/02	12.45	NP	8.15	0.0	4.30
	03/17/03	12.45	NP	7.28	0.0	5.17
	06/18/03	12.45	NP	7.72	0.0	4.73
	09/03/03	12.45	NP	8.18	0.0	4.27
	11/26/03	12.45	NP	8.55	0.0	3.90
	03/05/04	12.45	NP	6.92	0.0	5.53
	06/02/04	12.45	NP	7.92	0.0	4.53
	09/03/04	12.45	NP	8.16	0.0	4.29
	12/16/04	12.45	NP	7.62	0.0	4.83
	03/29/05	12.45	NP	6.63	0.0	5.82
	06/14/05	12.45	NP	7.60	0.0	4.85
	08/10/05	12.45	NP	7.50	0.0	4.95
	09/29/05	12.45	NP	7.76	0.0	4.69
	12/21/05	12.45	NP	6.90	0.0	5.55
	03/24/06	12.45	NP	6.65	0.0	5.80
	07/28/06	12.45	NP	7.34	0.0	5.11
	11/29/06	NA	NP	11.41	0.0	NA
	06/01/07	14.99	NP	11.26	0.0	3.73
	11/14/07	14.99	NP	11.40	0.0	3.59
	06/05/08	14.99	NP	11.45	0.0	3.54
	12/18/08	14.99	NP	11.30	0.0	3.69
	03/04/09	14.99	NP	10.07	0.0	4.92
	04/01/09	14.99	NP	10.92	0.0	4.07
	06/17/09	14.99	NP	11.40	0.0	3.59
	12/08/09	14.99	NP	11.64	0.0	3.35
	06/16/10	14.99	NP	11.75	0.0	3.24
	12/14/10	14.99	NP	10.75	0.0	4.24
	06/07/11	14.99	NP	10.51	0.0	4.48
	06/21/11	14.99	NP	10.64	0.0	4.35
	09/26/11	14.99	NP	11.21	0.0	3.78
	12/05/11	14.99	NP	11.29	0.0	3.70
MW-9						
	12/18/08	16.33	NP	12.88	0.0	3.45
	03/04/09	16.33	NP	11.04	0.0	5.29
	04/01/09	16.33	NP	11.51	0.0	4.82
	06/17/09	16.33	NP	11.95	0.0	4.38
	12/08/09	16.33	NP	12.30	0.0	4.03
	06/16/10	16.33	NP	11.75	0.0	4.58
	12/14/10	16.33	NP	11.51	0.0	4.82
	06/07/11	16.33	NP	11.32	0.0	5.01
	06/21/11	16.33	NP	11.37	0.0	4.96
	09/26/11	16.33	NP	11.92	0.0	4.41
	12/05/11	16.33	NP	11.99	0.0	4.34

**TABLE 1. Historical Groundwater Elevation and Free Product Data
Port of Oakland's Harbor Facilities Complex Site
555 - 651 Maritime Street, Oakland, California**

Monitoring Well	Date Measured	Elevation ¹ Top of Casing (feet)	Depth to Product (feet btc)	Depth to Water (feet btc)	Product Thickness (feet)	Groundwater Elevation ¹ (feet)
MW-10						
	12/18/08	15.65	NP	14.34	0.0	1.31
	03/04/09	15.65	NP	9.78	0.0	5.87
	04/01/09	15.65	NP	10.33	0.0	5.32
	06/17/09	15.65	NP	10.79	0.0	4.86
	12/08/09	15.65	NP	10.96	0.0	4.69
	06/16/10	15.65	NP	10.62	0.0	5.03
	12/14/10	15.65	NP	10.31	0.0	5.34
	06/07/11	15.65	NP	10.11	0.0	5.54
	06/21/11	15.65	NP	10.19	0.0	5.46
	09/26/11	15.65	NP	10.79	0.0	4.86
	12/05/11	15.65	NP	10.80	0.0	4.85
MW-11						
	12/18/08	15.47	NP	13.42	0.0	2.05
	03/04/09	15.47	NP	9.57	0.0	5.90
	04/01/09	15.47	NP	9.94	0.0	5.53
	06/17/09	15.47	NP	10.40	0.0	5.07
	12/09/09	15.47	NP	10.68	0.0	4.79
	06/16/10	15.47	NP	10.02	0.0	5.45
	12/01/10	15.47	NP	10.02	0.0	5.45
	06/07/11	15.47	NP	10.00	0.0	5.47
	06/21/11	15.47	NP	9.85	0.0	5.62
	09/26/11	15.47	NP	10.33	0.0	5.14
	12/05/11	15.47	NP	10.59	0.0	4.88
MW-12						
	12/18/08	16.79	NP	12.75	0.0	4.04
	03/04/09	16.79	NP	10.60	0.0	6.19
	04/01/09	16.79	NP	11.23	0.0	5.56
	6/17/2009	16.79	NP	11.83	0.0	4.96
	12/8/2009	16.79	NP	12.13	0.0	4.66
	6/16/2010	16.79	NP	11.31	0.0	5.48
	12/14/2010	16.79	NP	11.15	0.0	5.64
	6/7/2011	16.79	NP	10.81	0.0	5.98
	6/21/2011	16.79	NP	11.01	0.0	5.78
	9/26/2011	16.79	NP	11.77	0.0	5.02
	12/5/2011	16.79	NP	11.89	0.0	4.90

Notes:

Source of data prior to December 2005: Innovative Technical Solutions, Inc. *Third Quarter of 2005 Groundwater Monitoring and Product Monitoring Report*, 8 November 2005.

NP = no product detected with the interface probe

NC = not calculated due to the presence of free-phase product in the well

btc = below top of the well casing

NA = not available

NM = not measured

-- = no measurable product.

¹ Wells were resurveyed on January 24, 2009. Elevation data is relative to North American Vertical Datum of 1988 (NAVD 88).

² Well could not be measured due to abundant surface water covering well head.

³ Viscous product not related to the lighter product identified in other wells.

⁴ Product not measurable, but visible evidence of product on interface probe

Attachment 9

Historical groundwater flow direction figure

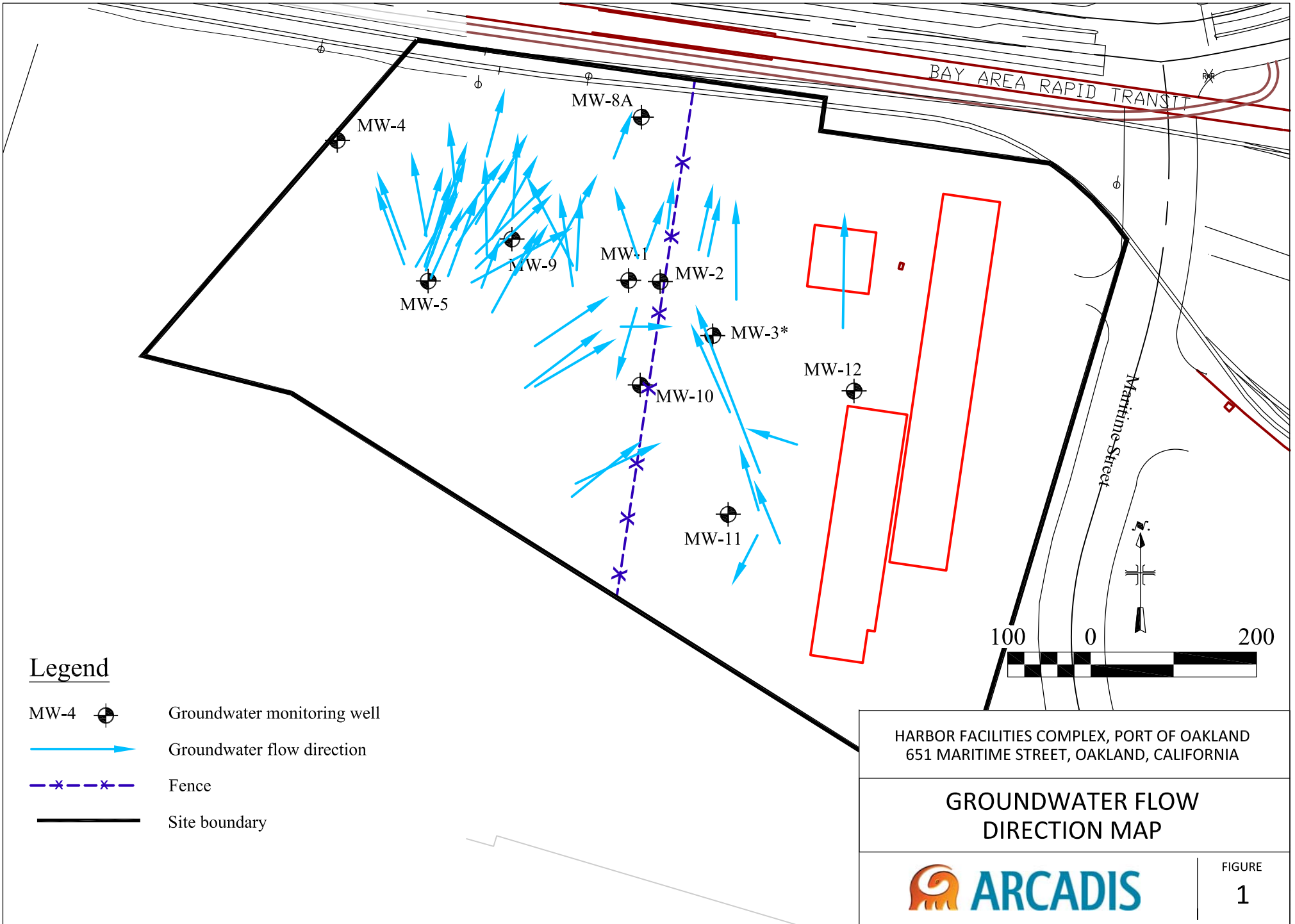

Attachment 10

Historical soil gas analytical results

TABLE 4: SOIL GAS CHEMICAL TEST RESULTS - Fixed Gases and Total Petroleum Hydrocarbons
Phase II Environmental Site Assessment
Future Port Field Support Services Complex
Port of Oakland
Oakland, California

LOCATION		MFC-01	MFC-03	MFC-05	MFC-07	MFC-10	MFC-13	MFC-14	MFC-15
MATRIX		Soil Gas	Soil Gas	Soil Gas	Soil Gas	Soil Gas	Soil Gas	Soil Gas	Soil Gas
COLLECTION DATE		3/27/02	3/27/02	3/27/02	3/27/02	3/27/02	3/27/02	3/27/02	3/27/02
DEPTH ⁽¹⁾		4.0	4.0	4.0	4.0	4.0	4.0	4.0	4.0
	UNITS								
Carbon Dioxide	% v	8.2	8.4	11	7.3	6.4	10	10	6.0
Oxygen	% v	2.5	4.1	6.0	11	8.4	1.3	0.91	9.4
Nitrogen	% v	92	89	82	83	88	85	65	63
Methane	% v	0.21	0.065	0.00070	0.00096	<0.00044	6.1	24	22
Carbon Monoxide	% v	<0.0027	<0.0022	<0.0020	<0.0019	<0.0022	<0.0024	<0.0021	<0.0017
Gasoline	ppmv	45	<2.2	<2.0	<1.9	<2.2	330	1,000	630

Notes:

(1) Soil Gas samples collected at an average depth of 4.0 feet below ground surface (bgs).

Samples collected in Summa Canisters.

% v = percent by volume (1% = 10,000 ppmv)

ppmv = parts per million by volume

Samples were analyzed for Petroleum Hydrocarbons in the gasoline range by EPA Method 19 TO-3 and for carbon dioxide, oxygen, nitrogen, methane, and carbon monoxide by ASTM D1946.

TABLE 4: SOIL GAS CHEMICAL TEST RESULTS - Fixed Gases and Total Petroleum Hydrocarbons
Phase II Environmental Site Assessment
Future Port Field Support Services Complex
Port of Oakland
Oakland, California

LOCATION		MFC-16	MFC-17	MFC-18	MFC-19	MFC-23	MFC-28	MFC-29	MFC-31
MATRIX		Soil Gas	Soil Gas	Soil Gas	Soil Gas	Soil Gas	Soil Gas	Soil Gas	Soil Gas
COLLECTION DATE		3/26/02	3/26/02	3/26/02	3/26/02	3/28/02	3/28/02	3/28/02	3/25/02
DEPTH ⁽¹⁾		4.0	4.0	4.0	4.0	4.0	4.0	4.0	4.0
	UNITS								
Carbon Dioxide	% v	6.3	7.7	17	13	0.039	1.6	0.87	2.1
Oxygen	% v	6.5	0.89	0.35	2.1	22	3.0	3.3	12
Nitrogen	% v	50	15	19	17	80	39	17	55
Methane	% v	37	76	64	68	0.0013	56	78	38
Carbon Monoxide	% v	<0.0030	<0.0022	<0.0020	<0.0021	<0.0027	<0.0021	<0.0029	<0.0043
Gasoline	ppmv	28,000	340	910	810	<2.7	13	78	290

Notes:

(1) Soil Gas samples collected at an average depth of 4.0 feet below ground surface (bgs).

Samples collected in Summa Canisters.

% v = percent by volume (1% = 10,000 ppmv)

ppmv = parts per million by volume

Samples were analyzed for Petroleum Hydrocarbons in the gasoline range by EPA Method 19 TO-3 and for carbon dioxide, oxygen, nitrogen, methane, and carbon monoxide by ASTM D1946.

TABLE 4: SOIL GAS CHEMICAL TEST RESULTS - Fixed Gases and Total Petroleum Hydrocarbons
Phase II Environmental Site Assessment
Future Port Field Support Services Complex
Port of Oakland
Oakland, California

LOCATION		MFC-33	MFC-35	MFC-36	MFC-37	MFC-38	MFC-41	MFC-45
MATRIX		Soil Gas	Soil Gas	Soil Gas	Soil Gas	Soil Gas	Soil Gas	Soil Gas
COLLECTION DATE		3/25/02	3/25/02	3/28/02	3/25/02	3/28/02	3/28/02	3/28/02
DEPTH ⁽¹⁾		4.0	4.0	4.0	4.0	4.0	4.0	4.0
	UNITS							
Carbon Dioxide	% v	1.8	3.8	8.0	7.1	0.083	2.7	0.19
Oxygen	% v	18	16	1.5	10	22	19	20
Nitrogen	% v	69	65	91	70	80	81	84
Methane	% v	17	19	1.9	18	0.17	<0.00042	0.077
Carbon Monoxide	% v	<0.0025	<0.0020	<0.0019	<0.0028	<0.0018	<0.0021	<0.0034
Gasoline	ppmv	140	170	85	140	<1.8	<2.1	6.9

Notes:

(1) Soil Gas samples collected at an average depth of 4.0 feet below ground surface (bgs).

Samples collected in Summa Canisters.

% v = percent by volume (1% = 10,000 ppmv)

ppmv = parts per million by volume

Samples were analyzed for Petroleum Hydrocarbons in the gasoline range by EPA Method 19 TO-3 and for carbon dioxide, oxygen, nitrogen, methane, and carbon monoxide by ASTM D1946.

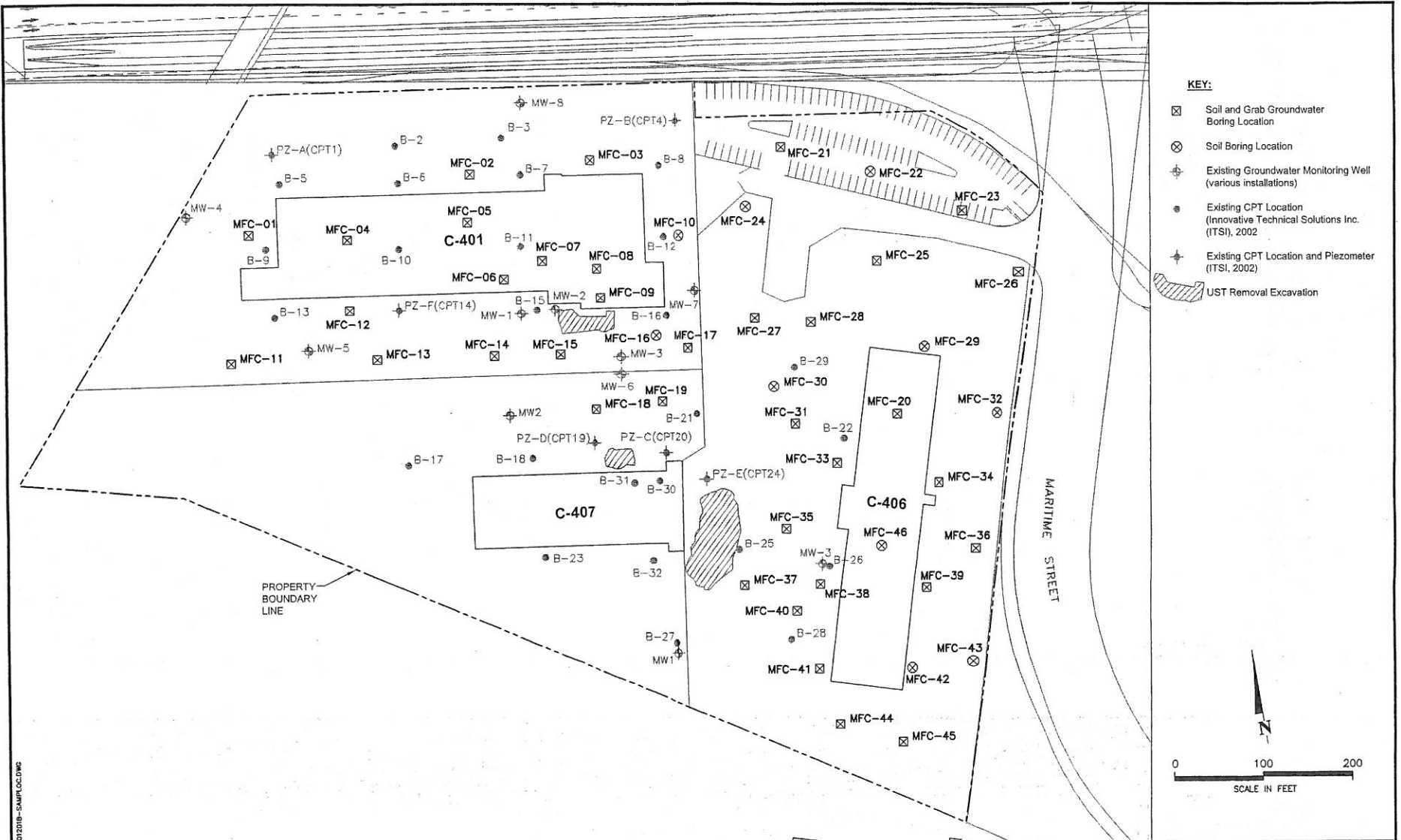

012018-SAMPLOC.DWG

IRIS ENVIRONMENTAL
1615 Broadway, Suite 1003, Oakland, California 94612

Sampling Locations and Site Layout
Port of Oakland Future Port Field Support Services Complex
2225 and 2277 7th Street
Oakland, California

Figure
2

Drafter: MAS

Date: 4/3/02

Contract Number: 01-20JB

Approved:

Revised:

Attachment 11

Aerial figure with current and historical site features

CITY: DIV/GROUP: DB: LD: PIC: PM: TM: TR:
Project (Project #)

