

RECEIVED

By Alameda County Environmental Health 2:49 pm, Dec 01, 2016



100 St Paul Street, Suite 300
Denver, CO 80206
303.371.9000
paulscorp.com

Ms. Dilan Roe
Alameda County Health Care Services Agency
Department of Environmental Health
1131 Harbor Bay Parkway, Suite 250
Alameda, CA 94502-6577

Re: 1233 Bockman Road
San Lorenzo, California
ACEH Case No: RO00003217

Dear Ms. Roe:

PaulsCorp, LLC, has retained Pangea Environmental Services, Inc. (Pangea) for environmental consulting services for the project referenced above. Pangea is submitting the attached report on my behalf.

I declare, under penalty of perjury, that the information and/or recommendations contained in the attached report are true and correct to the best of my knowledge.

Sincerely,

A handwritten signature in blue ink, appearing to read 'Andrew J. Lavaux'.

Andrew J. Lavaux
Managing Director Multifamily Development



November 29, 2016

Andrew Lavaux
PAULS Corporation, LLC
100 Saint Paul Street
Denver, Colorado 80206

Re: **VIMS Basis of Design Report**
Bockman Road Property
1233 Bockman Road
San Lorenzo, California 94577
ACDEH Case # RO00003217

Dear Mr. Lavaux:

On behalf of PAULS Corporation, LLC, PANGEA Environmental Services, Inc. (PANGEA) is pleased to present this *Vapor Intrusion Mitigation System Basis of Design Report, Construction Quality Assurance Plan, and Operations & Maintenance Plan – Buildings 1 – 4* (“Design Basis Report”) prepared for the project at 1233 Bockman Road, San Lorenzo, California (“the Site”). The overall development project includes the planned construction of 53 two-story residential units within 10 buildings at the property. This Design Basis Report pertains to Buildings 1 through 4. This plan was prepared at the request of the Alameda County Department of Environmental Health (ACDEH) during a meeting on November 17, 2016. If you have any questions or comments, please call me at (510) 435-8664 or email briddell@pangeaenv.com.

Sincerely,
PANGEA Environmental Services, Inc.

A handwritten signature in blue ink, appearing to read "Bob Clark-Riddell".

Bob Clark-Riddell, P.E.
Principal Engineer

Attachment: *Vapor Intrusion Mitigation System Basis of Design Report, Construction Quality Assurance Plan, and Operations & Maintenance Plan – Buildings 1 – 4*

PANGEA Environmental Services, Inc.



**VAPOR INTRUSION MITIGATION SYSTEM BASIS OF DESIGN
REPORT, CONSTRUCTION QUALITY ASSURANCE PLAN, AND
OPERATIONS & MAINTENANCE PLAN – BUILDINGS 1 – 4**

**1233 Bockman Road
San Lorenzo, CA 94577**

November 29, 2016

Prepared for:

PaulsCorp, LLC
100 Saint Paul Street
Denver, Colorado 80206

Prepared by:

PANGEA Environmental Services, Inc.
1710 Franklin Street, Suite 200
Oakland, California 94612

Written by:



A handwritten signature in blue ink that reads "Ron Scheele".

Ron Scheele, P.G.
Principal Geologist

A handwritten signature in blue ink that reads "Bob Clark-Riddell".

Bob Clark-Riddell, P.E.
Principal Engineer

Table of Contents

1.0 INTRODUCTION.....	1
1.1 DOCUMENT PURPOSE AND SCOPE	2
2.0 PROJECT AND MITIGATION OBJECTIVES.....	2
2.1 DESIGN OBJECTIVES AND BASIS.....	2
2.2 MITIGATION OBJECTIVES	3
2.2.1 <i>Soil Gas</i>	3
2.2.2 <i>Indoor Air</i>	3
3.0 VAPOR MITIGATION SYSTEM DESIGN	4
3.1 KEY DESIGN PARAMETERS	5
3.2 SUB-SLAB VENTILATION (SSV) SYSTEM	5
3.2.1 <i>Maximum Allowable Design Flow Rate</i>	6
3.2.2 <i>Permeable Base</i>	8
3.2.3 <i>Vapor Collection Piping</i>	8
3.2.4 <i>Vapor Collection Risers</i>	8
3.2.5 <i>Wind-Driven Turbine Fan</i>	8
3.2.6 <i>SSV System Layout</i>	8
3.3 MOISTURE BARRIER SYSTEM	9
3.4 SLAB PENETRATION SEALING	9
3.5 CLOSURE OF POTENTIAL PREFERENTIAL PATHWAYS	9
3.6 CONTINGENT ENGINEERED VAPOR BARRIER SYSTEM.....	9
4.0 VIMS IMPLEMENTATION	10
4.1 PRECONSTRUCTION ACTIVITIES	10
4.2 VIMS INSTALLATION.....	10
4.2.1 <i>Mobilization and Site Preparation</i>	10
4.2.2 <i>Environmental Controls for Stormwater and Dust</i>	10
4.2.3 <i>Waste Management</i>	11
4.2.4 <i>Site Restoration, Project Closeout, and Demobilization</i>	11
4.2.5 <i>Survey</i>	11
5.0 CONSTRUCTION QUALITY AND ASSURANCE PLAN	11
5.1 CONSTRUCTION QUALITY ASSURANCE ROLES AND COORDINATION.....	11
5.2 QUALITY CONTROL FOR VIMS INSTALLATION	12
5.2.1 <i>VIMS Materials Quality Control</i>	12
5.2.2 <i>VIMS Construction Quality Control</i>	12

6.0 OPERATIONS AND MAINTENANCE PLAN.....	13
6.1 VIMS PERFORMANCE MONITORING	13
6.1.1 Vent Riser Sampling.....	13
6.1.2 Vent Flow Rate Adjustment.....	14
6.1.3 Monitoring for Installation of Contingent Engineered Vapor Barrier.....	14
6.1.4 Indoor Air Sampling	14
6.1.5 Monitoring for Active Sub-Slab Depressurization	15
6.2 VIMS MAINTENANCE	15
6.2.1 Normal Operation of System	15
6.2.2 Monitoring and Regular Maintenance	15
6.2.3 Recordkeeping and Reporting	15
6.2.4 System Disruptions, Alterations, Repairs, and Improvements.....	16
6.2.5 Annual Review.....	16
6.2.6 Measures for the Termination of Long Term O&M	17
6.2.7 Event Response.....	17
7.0 REPORTING AND SCHEDULE	17
7.1 DOCUMENTATION AND REPORTING.....	17
7.2 PRELIMINARY SCHEDULING	18
8.0 REFERENCES.....	19

ATTACHMENTS

Figure 1	Vicinity Map
Figure 2	Site Map
Appendix A	Development Plans
Appendix B	VIMS Design Drawings
Appendix C	Wind Turbine Fan and Active Blower Specifications
Appendix D	RetroCoat™ Vapor Barrier Information

1.0 INTRODUCTION

On behalf of PaulsCorp, LLC, Pangea Environmental Services, Inc. is pleased to present this *Vapor Intrusion Mitigation System Basis of Design Report, Construction Quality Assurance Plan, and Operations & Maintenance Plan – Buildings 1 – 4* (“Design Basis Report”) prepared for the project at 1233 Bockman Road, San Lorenzo, California (“the Site”)(Figure 1). The overall development project includes the planned construction of 53 two–story residential units within 10 buildings at the property. This Design Basis Report pertains to Buildings 1 through 4. This plan was prepared at the request of the Alameda County Department of Environmental Health (ACDEH) during a meeting on November 17, 2016.

Subsurface investigations previously performed at the Site by others have identified several volatile organic compounds (VOCs), including benzene, ethylbenzene, and tetrachloroethylene (PCE), in soil gas at the Site at concentrations that *may* pose a potential risk to indoor air quality for future residential users at the Site. In general, the VOC presence within the *western* portion of the Site beneath planned Buildings 1 through 4 may be associated with historic releases at the former *automotive repair facility* at 1415 Bockman. A site map is provided as Figure 2. The locations planned Buildings 1 through 4 are shown on Figure 2 and in Appendix A.

Available data indicates that VOC concentrations in soil gas beneath Buildings 1 through 4 are generally below conservative environmental screening levels. Absent longer-term data, ACDEH is requiring initial vapor intrusion mitigation measures with contingent measures based on subsequent data at Buildings 1 through 4. To mitigate potential risk and protect indoor air quality, ACDEH has approved the following vapor mitigation approach for the western portion of the site (Buildings 1-4):

- Installation of a subslab ventilation system (SSV) beneath each building slab;
- Subslab gas monitoring after slab construction and before occupancy; and
- Contingent installation of a post-slab engineered vapor barrier system (e.g., Retro-Coat™ by Land Science®), applied to the building floor slab across the entire accessible building footprint.

A detailed description of the project background and the nature and extent of VOCs in the subsurface is provided in the October 7, 2016 *Draft Corrective Action Plan* (Pangea, 2016a), the October 26, 2016 *Interim Remediation Report* (Pangea, 2016b), and November 16, 2016 *Data Gap Investigation Report, Buildings 3 & 4* (Pangea, 2016c).

This Design Basis Report describes the construction of a vapor intrusion mitigation system (VIMS) comprised of the SSV piping and the contingent post-slab construction engineered vapor barrier. This VIMS is consistent with the Draft CAP and agency requirements. Subslab gas monitoring is described below in Section 6.1.1. A

construction quality assurance plan is presented in Section 5. A long-term O&M plan is described in Section 6.

VOCs presence within the *eastern* portion of the Site beneath planned Buildings 5 through 10 may be associated with historic releases at the former historic *dry cleaner* at 1269 Bockman Road, and/or the former offsite sources at 1210 Bockman (former Impulse Motors fueling station/auto repair facility). A separate Design Basis Report will be prepared for future VIMS for the other planned development (Buildings 5 through 10) at the Site. The locations planned Buildings 5 through 10 are shown on Figure 2 and in Appendix A.

A Post-Construction Site Management Plan (SMP) will be prepared following completion of VIMS installation, construction, and testing. The Post-Construction SMP will include a Record Report of Construction (As-Builts for VIMS, trench plugs, etc), final O&M plans, tenant notifications (Proposition 65), and deed restriction (if required).

1.1 Document Purpose and Scope

This document has been prepared to establish the basis for the detailed engineering design of the proposed VIMS at the Site, present key design components of the proposed VIMS, provide specific procedures for VIMS construction quality assurance (CQA), and present a long-term operation and maintenance (O&M) plan. Per the CQA procedures, the VIMS Design Engineer will be present on site during construction of the VIMS to observe and certify that the implementation is consistent with the construction documents. The O&M procedures presented herein are to be implemented by the Owner or a Responsible Party designated by the Owner.

2.0 PROJECT AND MITIGATION OBJECTIVES

2.1 Design Objectives and Basis

The objectives of the VIMS are as follows:

- Mitigate the potential for soil vapor beneath future building slabs to contribute to unacceptable risk in indoor air by installing vapor collection piping below the new building slab to passively vent sub-slab vapors above the roofline, and by installing a contingent post-slab engineered vapor barrier if merited based on sub-slab gas monitoring.
- Maintain vapor concentrations within the buildings below long-term air quality objectives for chemical of concern (COC) that include benzene, ethylbenzene, and PCE and its breakdown products.

- Provide a mitigation system that is passive and requires minimal operation and maintenance.
- Design a system that could be converted from a passive system to an active system, if needed.

The October 2011 *Vapor Intrusion Mitigation Advisory, Revision 1, Final* (VIMA) issued by the California Department of Toxic Substances Control (DTSC, 2011) and the methane mitigation standards established by the Los Angeles Department of Building and Safety (LADBS) provide general requirements for the design, implementation, and long term O&M of designed sub-slab mitigation systems. These agency guidance documents were used to guide the design of the proposed VIMS described herein.

2.2 Mitigation Objectives

The VIMS mitigation objectives are based on the ESLs for soil gas and indoor air (Regional Water Board, 2013), for residential land use. As described by the Regional Water Board, ESLs are conservative screening levels that correspond to an acceptable risk level; concentrations of constituents below their respective ESLs can be considered to pose no significant risk, within noted limits. Concentrations of constituents above their respective ESLs do not necessarily indicate a risk is present, but rather suggest that additional evaluation is warranted.

2.2.1 Soil Gas

The objective of the VIMS is to maintain concentrations of COCs at concentrations below their respective ESLs in subslab/soil gas beneath the future site buildings (Table SG-1, Regional Water Board, 2016). The specific treatment objectives for the primary COCs in subslab/soil gas are based on the lowest residential endpoint in Table SG-1 as shown below on Table A. Should the indoor air ESLs be updated, the effectiveness of the corrective action will be assessed relative to whatever ESLs are current at the time.

2.2.2 Indoor Air

The objective of the VIMS is to maintain concentrations of COCs at concentrations below their respective indoor air ESLs in indoor air within the future site buildings (Table IA-1, Regional Water Board, 2016). The specific treatment objectives for the primary COCs in indoor air based on the lowest residential endpoint in Table IA-1 as shown below on Table A.

Table A – Residential Screening Levels for Soil Gas and Indoor Air

Chemical	Soil Gas Tier 1 ESL (ug/m3)	Indoor Air Tier 1 ESL (ug/m3)
PCE	240	0.48
Benzene	48	0.097
Ethylbenzene	560	1.1

Should the indoor air ESLs be updated, the effectiveness of the corrective action will be assessed relative to whatever ESLs are current at the time.

3.0 VAPOR MITIGATION SYSTEM DESIGN

Consistent with the Draft CAP and agency requirements, the proposed VIMS includes a venting system and a contingent engineered vapor barrier system. The VIMS will be installed within the proposed residential buildings during construction and before occupancy of these buildings. The venting system will provide a route for the VOC-affected soil gas that would otherwise collect beneath the building slab and barrier system to vent directly to the atmosphere outside the building while also providing a slight negative pressure beneath the building. The barrier system is intended to sufficiently retard the migration of VOC-affected soil gas into the onsite building such that VOCs in soil gas do not represent an unacceptable risk to future residential users of the Site. The procedure for evaluating the need for the contingent vapor barrier involves sub-slab gas monitoring described below. The sub-slab venting system is designed for conversion to an active sub-slab depressurization/venting system if performance monitoring results indicate the passive venting system is not providing sufficient mitigation of VOC vapors.

The VIMS includes the following elements:

- Installation of a sub-slab ventilation (SSV) system beneath each building slab;
- Installation of a sub-liner moisture vapor barrier above the SSV system;
- Sealing of slab penetrations and cracks using Retro-Coat™ Caulk and Retro-Coat™ Gel or comparable polyurethane material;
- Closure of potential preferential pathways (e.g., trench plugs for utilities);
- Sub-slab gas monitoring after slab construction and before occupancy; and

- Contingent installation of a post-slab engineered vapor barrier system (e.g., Retro-Coat™ by Land Science®), applied to the building floor slab across the entire accessible building footprint.

The elements of the venting system and contingent engineered barrier system are depicted in the *Vapor Intrusion Mitigation System (VIMS) Design Drawings* dated November 7, 2016, included as Appendix B.

3.1 Key Design Parameters

The following key parameters were used for the design of the vapor collection system and contingent vapor mitigation barrier:

- Types of soil vapor contaminants and concentrations.
- Commercially available vapor mitigation systems (membranes and/or venting) and their expected performance.
- Current extent of soil vapor plumes.
- Proposed building foundation design.
- Building footprint area.
- Collection piping head losses.
- Wind-turbine fan manufacturer specifications.
- Regulatory permitting.
- Regulatory advisories; the VIMS will be installed in general accordance with the recommendations outlined in the *Vapor Intrusion Mitigation Advisory* published by the California Department of Toxic Substances Control (DTSC, 2011).

3.2 Sub-Slab Ventilation (SSV) System

A passive sub-slab venting (SSV) system will be installed beneath each building slab. The SSV system is intended to be passive and long lasting, and to require minimal operations and maintenance activities. The SSV system consists of a trench, a layer of permeable material, horizontal vapor collection piping within the permeable material layer, vent risers attached to the vapor collection pipes that run to the roof, with the potential for a wind-driven turbine fans installed at the top of the vent risers. The purpose of the SSV is to provide protection by extracting soil vapor that may accumulate in the subsurface. A description of the selected flow rate for the SSV system and a description of each component are presented below.

Sub-slab components of the venting system include a network of a 3-inch diameter perforated Schedule 40 PVC piping embedded within a four-inch thick permeable layer of crushed rock (100% passing 1-inch; 90%

passing ¾-inch; 10% maximum passing #4) directly beneath the building slab. The vent piping network includes fresh air inlet vent piping as well as outlet vent piping that will be connected to vent risers that trend through the building interior or exterior, conveying the collected soil gas to the roof level for discharge to the atmosphere. The design includes one vent riser pipe for approximately every 4,000 to 6,000 square feet depending on the building layout (LADBS). The vent risers will be three-inch diameter, solid, ductile iron pipe (DIP) or cast iron pipe (CIP) to protect the pipe from potential future damage. Vent risers will be labeled “CONTAINS VAPORS: DO NOT BREAK OR CUT.” The engineered vent material will be installed in accordance with the applicable manufacturer recommendations and specifications.

The passive venting system is designed with appropriate features to allow future modification to an active system, if deemed necessary. The venting system can be converted to an active system with the addition of a blower connected to the VIMS riser piping either within the attic space or at the roof. The blower would mechanically move VOC-affected soil gas through the venting system and provide active sub-slab depressurization. A fan (RP 140 Radon Fan or equivalent) would be installed at each riser location. Manufacturer cut sheets for the proposed blowers are included as Appendix C.

3.2.1 Maximum Allowable Design Flow Rate

SSV systems generally do not require abatement for the vapors being vented to the atmosphere due to the relatively low concentrations and flow rates and, therefore, low mass loading. Furthermore, passive venting systems often operate at very low pressures such that addition of abatement equipment can have a significant effect on the system’s venting performance. Regulatory requirements set forth by the Bay Area Air Quality Management District (BAAQMD) exempt passive soil vapor extraction operations with operations with total emission of less than one pound per day per BAAQMD Regulation 8, Rule, 47, Section 8-47-113 (BAAQMD, 2005).

Therefore, to maintain the intent of the VIMS objectives of a passive system that requires minimal maintenance, the VIMS will be designed to operate below the threshold requiring abatement. The methodology used to estimate the maximum allowable design flow rate is described below.

The maximum allowable design flow rate for the SSV system was determined based on the historical soil vapor concentrations and estimated future VOC concentrations. The use of the estimated soil vapor concentrations for the SSV influent (as opposed to the maximum detected soil vapor concentrations to estimate the maximum flow rate through the vents) is representative of expected subsurface soil vapor concentrations and is conservative based on the following: 1) soil vapor concentrations are expected to reduce given the recent removal of select source material, 2) contaminant concentrations are expected to attenuate as soil vapor travels from subgrade soils to the soil vapor collection system; and 3) soil vapor

concentrations are expected to diminish due to mixing with cleaner air during venting and ambient air intake within the soil vapor collection system.

The estimated future VOC concentrations shown below in Table B were used to calculate the maximum allowable flow rate per vent to meet BAAQMD 8-47-113 exemption. Pangea estimates a minimum 50% reduction in VOC concentration as soil vapor travels from subgrade soils into the vapor collection system. Pangea also estimates a minimum 50% further reduction in VOC concentration as ambient air mixes within the soil vapor collection system.

Table B – Average VOC Concentrations in Soil Gas

Chemical	Building 1	Building 2	Building 3	Building 4
	Average Concentration (micrograms per cubic meter)			
PCE	<10	<17	<15	30
Benzene	12	<42	6	8
Ethylbenzene	<6	<11	<5	<5
Total VOCs	<28	<70	<26	<43
50% Reduction into subslab zone	<14	<35	<13	<22
50% Reduction in collection system	<7	<18	<7	<11
Estimated Max VOCs in Riser	<7	<18	<7	<11

Based on these soil vapor concentrations, the estimated average VOC concentration in each riser is approximately <11 ug/m³. As shown below, the maximum allowable flow rate calculated for each of the 8 vents is 126 cubic feet per minute (ft³/min) vents to remain under the pound per day emission limit per BAAQMD Regulation 8, Rule 47, Section 8-47-11. The maximum allowable vent flow rate calculation is as follows:

Mass Removal Calculation:

$$\underline{X} \text{ ug/L} \times \underline{Y} \text{ cfm} \times 0.00009 \text{ (conversion to yield lbs/day)} = 1 \text{ lbs/day (BAAQMD limit)}$$

$$<11 \text{ ug/L} \times \underline{Y} \text{ cfm} \times 0.00009 \text{ (conversion to yield lbs/day)} = 1 \text{ lbs/day (BAAQMD limit)}$$

$$Y = 1,010 \text{ CFM}$$

$$Y = 1,010 \text{ CFM} / 8 \text{ Riser Vents} = 126 \text{ CFM/Riser Vent}$$

Performance monitoring and system controls for measuring and adjusting the system flow rate and contingency plans are provided below.

3.2.2 Permeable Base

The permeable base layer will consist of a minimum of 4 inches of gravel or crushed rock placed continuously around the VIMS piping below grade. The permeable material will surround the vapor mitigation piping. The permeable base will provide a continuous, highly permeable zone that allows advective flow of soil vapor to the collection piping.

3.2.3 Vapor Collection Piping

The vapor collection piping will be 3” diameter perforated Schedule 40 PVC pipe. The 3” piping is chosen to be large enough to allow vapor flow. The slotted pipe will connect to a 3” diameter cast-iron pipe (CIP) prior to grade. The layout for the vapor collection piping was designed to cover the entire area under each building. The layout of the vapor collection piping is presented in Appendix B.

3.2.4 Vapor Collection Risers

The horizontal vapor collection piping will be connected to vertical vent riser piping, a 3” diameter CIP. The piping will be installed at a minimum of 10’ from the property line, as shown on the drawings in Appendix B. The 3” diameter CIP will be mounted to the building as shown on the drawings. The vent will continue past the roof and terminate approximately 1 foot above the roof.

The selected 3-inch vent piping is capable of conveying in excess of 650 ft³/min of air with minimal pressure drop and has more than sufficient capacity to convey the design flow rate of the wind-driven turbine fan.

A single 3-inch vent is capable of servicing a vapor mitigation membrane that covers an area ranging from 4,000 to 6,000 square feet (ft²)(LADBS).

3.2.5 Wind-Driven Turbine Fan

A wind-driven turbine fan will be installed at the top of the riser vent to provide wind siphoning flow from the vent. The selected wind-driven turbine fan creates a vacuum that draws air out from the VIMS. The air flow for the 12” diameter fan (McMaster-Carr Catalog# 1992K48 or equivalent) is 440 cfm at 4 mph wind. The fan requires no power to operate. Performance monitoring described below will determine if the fan flow rate requires reduction, or if fan removal is required to allow passive ventilation without a fan.

3.2.6 SSV System Layout

The layout of the soil vapor collection system is design to vent vapors from beneath the entire slab of reach building.

3.3 Moisture Barrier System

A moisture barrier system will be installed beneath the concrete building slab. This moisture barrier will function as a limited sub-liner membrane. The moisture vapor barrier will be a minimum 15-mils thickness, polyolefin plastic sheeting, such as Stego-Wrap™. The moisture barrier system included procedures for sealing the barrier around the foundation and sealing penetrations. The moisture vapor barrier does not fully comply with State VIMA guidance from DTSC for an engineered *vapor* barrier system, which specifies a 60-mils thickness of high-density polyethylene (HDPE) sub-liner membrane, so the planned system is relied upon as a *moisture* barrier.

3.4 Slab Penetration Sealing

As an added precaution, potential preferential pathways (such as cracks, imperfection to the slab, or other penetrations that would not be readily accessible during contingent vapor barrier installation following subslab gas monitoring) will be sealed using Retro-Coat™ Caulk and Retro-Coat™ Gel or comparable polyurethane material, as appropriate.

3.5 Closure of Potential Preferential Pathways

Utility line backfill will be sealed at or near the building perimeter and between designated VIMS sectors using a sand/cement slurry or controlled density fill (CDF) plug to limit vapor migration within the utility trench. Mechanical and electrical conduits originating from beneath the building floor slabs will also be sealed with a conduit seal to prevent migration of VOC-affected soil gas into the building. VIMS drawings in Appendix B include typical details for conduit seals and trench plugs. The utility system plan is included in Appendix A. A site plan showing locations of trench plugs will be included in the completion report record drawing set. Unused site utilities, if any, will be abandoned and sealed where appropriate.

3.6 Contingent Engineered Vapor Barrier System

The proposed contingent engineered barrier system will be a minimum 20-mils dry thickness, post-slab, very low permeability vapor barrier, such as Retro-Coat™ by Land Science®, applied on top of the structural floor slab across the building footprint as shown in Appendix B. To help avoid damage, the vapor barrier will be applied just prior to the floor finishes. The engineered system would not be installed beneath select framing, the stairways and counters, as shown on Appendix B. Potential preferential pathways such as cracks, annular spaces, pipe penetrations, or other imperfections that may be identified will be sealed using Retro-Coat™ Caulk and Retro-Coat™ Gel, as appropriate. The engineered barrier system will be installed in accordance with the applicable manufacturer recommendations and specifications. Manufacturer's specifications for Retro-Coat™ are included as Appendix D.

The procedure for evaluating the need for the contingent vapor barrier involves sub-slab gas monitoring described below in Section 6.1.1.

4.0 VIMS IMPLEMENTATION

The following sections describe the activities associated with the construction of the VIMS, including preconstruction activities and installation.

4.1 Preconstruction Activities

A preconstruction meeting with property owner or representatives are required for the installation of the VIMS. VIMS installation will be performed by an appropriately licensed contractor. Prior to initiating field activities, the following tasks will be conducted:

- Obtain authorization from ACDEH and City of San Lorenzo, as necessary.
- Pre-mark any excavation area with white paint and notify Underground Service Alert (USA) of the excavation activities at least 48 hours before work begins;
- Prepare a Site-specific health and safety plan to educate personnel and minimize their exposure to potential hazards related to Site activities; and
- Coordinate with involved parties.

4.2 VIMS Installation

The following sections describe the major activities required for the installation of the VIMS.

4.2.1 Mobilization and Site Preparation

Site preparation will include identification of layout of the VIMS, and locate any and all utilities near work zone. Establish exclusion zone.

4.2.2 Environmental Controls for Stormwater and Dust

All nearby storm drains will be protected from sediment. Minimal visible dust generation is expected during SSV system installation. As necessary, general construction dust controls, including spraying/misting with water during grading, minimizing material drop height during placement, and protection of material stockpiles, will be implemented during installation of the VIMS. These controls are a subset of the Storm Water Pollution Prevention Plan and the Air and Dust Monitoring Plans prepared for this Site.

4.2.3 Waste Management

Grading and waste material will be managed during general construction activities.

4.2.4 Site Restoration, Project Closeout, and Demobilization

After VIMS installation, the contractor will demobilize from the site after receiving approval by the owner and VIMS engineer. As necessary, contractors may be required to return to the site to address deficiencies identified at startup/commissioning of the VIMS. General project closeout procedures will include owner and project engineer inspections and approvals of the installations. Closeout documents will include as-built markups of design drawings, documentation of installed materials and equipment, available operation and maintenance manuals, and written warranties (as applicable) for work and installed products. Project recordkeeping and documentation is detailed below in Sections 6.2.3 and 7.1.

4.2.5 Survey

As-built alignments of installed horizontal piping and locations of the vent riser slab penetrations shall be clearly marked on the design drawings. The As-built drawings will not be performed by a licensed surveyor.

5.0 CONSTRUCTION QUALITY AND ASSURANCE PLAN

This section presents the construction quality assurance (CQA) plans for the VIMS installation.

5.1 Construction Quality Assurance Roles and Coordination

The CQA coordination will include a *preconstruction meeting* between the owner, VIMS design engineer, construction quality manager (CQM), and contractor. The pre-construction meeting will serve to introduce all parties and establish the chain of command and lines of communications for the project. This and other meetings will include other trades that may be affected by the installation of the systems or must know to protect the systems during the performance of their activities. For the VIMS construction, the contractors will be required to document installation prior to backfilling and finishing the job.

During the construction of the VIMS, the owner will be regularly updated on progress and variances of the VIMS design and schedule. CQA roles are presented in Table C.

Table C – Construction Quality Assurance Roles

Role	Firm	Person(s)
Owner	PaulsCorp, LLC	Andrew Lavaux, Scott Shoeman
Environmental Consultant	Pangea Environmental	Bob Clark-Riddell, PE
VIMS Design Engineer	Langan Treadwell Rollo	Sigrida Reinis, PE; Hayley Baker
Construction Quality Manager (CQM)	DCI Construction	Michael Gonzales, Caleb Cooper
Engineered Barrier Contractor (Contingency)	TBD	TBD
Contractors	TBD	TBD

5.2 Quality Control for VIMS Installation

The VIMS Design Engineer will be present on site during construction of the VIMS to observe that the implementation is consistent with the intent of the design and the design documents. In addition, the construction quality assurance and quality control (QA/QC) protocol specified herein will be implemented during the installation.

5.2.1 VIMS Materials Quality Control

The contractor will inspect all material prior to installation. The CQM will oversee the material inspection. All materials used shall be free of defects and damages. The manufacturer will provide certification-testing documentation that the materials specified meet or exceed the minimum design requirements.

5.2.2 VIMS Construction Quality Control

Construction of the subsurface piping will be performed by an appropriately qualified licensed contractor. Regularly scheduled visual inspections will be performed by the CQM during construction of the VIMS to verify conformance with design drawings and specifications. Prior to completion of the vent risers at roof levels, the vent setback and clearance will be verified for conformance with the requirements. Testing will be conducted to ensure the venting system operates as designed. The testing will include, but may not be limited to, monitoring and/or sampling of soil gas in the vent riser piping.

If the contingent post-slab engineered vapor barrier is required, the vapor barrier will be installed by appropriately qualified and manufacturer-certified contractors. They will have appropriate experience for installing the specified engineered barrier and related products. Testing procedures will ensure that the applied barrier system has been installed in accordance with the design and manufacturer recommendations

and without defects. These tests may include, but are not limited to, visual inspection and verification of application thickness, and a smoke test.

Upon completion of the final VIMS, a report will be prepared documenting that the installation was performed in accordance with the design and manufacturer specifications and that the specific construction QA/QC procedures were performed and yielded satisfactory results. The report will also include a signed and stamped record drawing set documenting the ‘as-built’ construction of the VIMS, including necessary field changes to the design.

6.0 OPERATIONS AND MAINTENANCE PLAN

Operations, maintenance, and monitoring (O&M) activities will support the objectives of the VIMS design. The VIMS constitutes a long-term, passive approach to remediating and mitigating risks to indoor air. Routine operations and maintenance activities are generally not required. Non-routine maintenance activities may be required if unexpected maintenance needs are observed during routine performance monitoring. Monitoring of the VIMS will be conducted to verify that it is functioning as intended at the time of installation.

A performance monitoring phase will occur shortly after installation to verify that each mitigation measure is functioning as intended. Following installation of the VIMS, the owner will retain the services to performance monitoring, operations, and maintenance. The Primary Operator will be responsible for performing site inspection, sampling, and data evaluation. The Primary Operator, to be established by the Owner, will be an environmental consultant, VIMS design engineer, or other owner representative.

6.1 VIMS Performance Monitoring

Performance monitoring will be conducted to confirm the efficacy of the installed VIMS and to demonstrate that VOC concentrations are below established screening levels. The performance of the VIMS will be evaluated by sampling soil gas in the vent riser piping as specified below.

6.1.1 Vent Riser Sampling

Vent riser performance monitoring will consist of collection of flow rate data and collection of samples of vented soil vapor from the riser by the environmental consultant or VIMS design engineer. The flow rate data and vapor samples will be collected from the sampling port installed within each riser pipe. The riser pipes are located within the exterior walls to facilitate sampling within minimal disruption to building residents. The vented soil vapor sample collected in 1-liter Summa canisters will be sent for state-certified laboratory analysis for the presence of site-specific chemicals of concern by EPA Method SIM TO-15. Flow rate and vented soil vapor concentrations will be used to calculate the emissions from each vent riser. Additional

monitoring may be performed using a photo-ionization detector (PID) to further evaluate VOC concentrations trends in vented soil gas.

Initial vent monitoring and sampling using Summa canisters will be conducted within approximately *one month* of installation of the VIMS and the concrete slab. A second vent monitoring will be conducted approximately *one to two months later* to confirm stable and acceptable VOC concentrations in subslab gas. The monitoring frequency may be revised in order to comply with any monitoring requirements of ACDEH or BAAQMD. The owner will notify ACDEH of any proposed changes to the monitoring or sampling schedule.

6.1.2 Vent Flow Rate Adjustment

Adjustments to the vent riser flow rate will be performed as necessary to maintain total combined emissions (aggregate of all vents) to less than 1 pound per day as required by BAAQMD regulations for unabated sources (BAAQMD, 2005). A valve or restriction can be provided to reduce vapor flow as merited. Or the wind-driven turbine fan can be replaced with a rain guard to allow passive venting.

6.1.3 Monitoring for Installation of Contingent Engineered Vapor Barrier

Sub-slab gas monitoring data collected from vent risers prior to final floor finishes will be provided to ACDEH to comment on the potential need for the contingent engineered vapor barrier. If VOC concentrations exceed 75% of the applicable environmental screening levels established by the San Francisco Bay Regional Water Quality Control Board, the contingent engineered vapor barrier will be installed for the building of concern unless otherwise directed by ACDEH. To minimize potential damage, the contingent engineered vapor barrier would be installed after most construction and just before final floor finishes.

6.1.4 Indoor Air Sampling

If sub-slab soil gas concentrations in the vent riser piping indicates presences of VOCs above the applicable ESLs after the first few months of SSV operation, indoor air sampling within the constructed building will be conducted to further confirm proper performance of the VIMS and evaluation of contingent active sub-slab depressurization. Indoor air monitoring can be performed before and/or during building occupancy.

Conversion to active sub-slab depressurization can be performed at any time. Conversion would involve installation of a powered fan and routing of electrical service via the contingent electrical conduit. The powered fan would be installed of in the attic or on the roof level.

6.1.5 Monitoring for Active Sub-Slab Depressurization

Monitoring of sub-slab gas and indoor air for evaluation of contingent active sub-slab depressurization is described in Section 6.1.4. If VOC concentrations in indoor air exceed applicable environmental screening levels established by the San Francisco Bay Regional Water Quality Control Board, the passive SSV system will be converted to active sub-slab depressurization. Additional mitigation measures may be implemented to comply with ACDEH requirements if indoor air concentrations of site-specific compounds exceed ESLs.

6.2 VIMS Maintenance

Because the VIMS is an engineered protection for the building, proper O&M is required to ensure that the system is not damaged and remains operational over the life of the building, or until soil gas concentrations have been reduced to below levels of concern. This long-term O&M plan has been prepared for this purpose.

Long-term O&M of the VIMS will be the responsibility of Owner or Designated Responsible Party. The Owner or Designated Responsible Party shall be responsible for ensuring that the VIMS is maintained by Site personnel who have reviewed the record drawings and this plan, and are thereby familiar with the system operations.

6.2.1 Normal Operation of System

There are no mechanized components to the passive SSV. VOC-affected soil gas is passively vented to the outdoor ambient air due to temperature and pressure gradients, the roof vents are open to allow the passive VIMS to operate continuously. Note that if the system is made active, emissions monitoring and a Bay Area Air Quality Management District (BAAQMD) permit may be necessary and this O&M Plan will be updated.

6.2.2 Monitoring and Regular Maintenance

At a minimum, system inspection will be conducted on a quarterly basis. The system components will be repaired or replaced for operational reliability as the need of repair or replacement is identified during each scheduled monitoring period. No major replacement or troubleshooting should be performed without the help of a Professional Engineer registered in the State of California and specializing in the design of VIMS.

6.2.3 Recordkeeping and Reporting

During the operation and maintenance of the VIMS, the monitoring and maintenance tasks discussed above will be performed and recorded in a monitoring and maintenance logbook. The logbook pages will be numbered to avoid loss of entry or to control unnecessary extraneous entry. The logbook shall include:

- Copies of completed inspection forms for each inspection event.

- Copies of any pictures taken during inspection events, repair activities, etc.
- Copies of any approvals, work plans, design drawings and specifications, and/or other necessary engineering design documents prepared for any major alteration to the VIMS.
- Information/entries recording emergencies, unusual events, or activities that may have affected the VIMS.
- Information/entries recording any adjustments, changes, or repairs to the VIMS.

It is the duty of the Owner or Designated Responsible Party to ensure that the proper records are maintained. In addition, the Owner or Designated Responsible Party will prepare an annual summary of its inspections, which will include copies of the entries made in the log book, for submittal to the ACEHD. The annual summary will include an evaluation of the VIMS effectiveness, any deficiencies noted, and proposed repairs in the case deficiencies are observed.

6.2.4 System Disruptions, Alterations, Repairs, and Improvements

If future building improvement plans include cutting or drilling through the floor slab and possibly disturbing the SSV system or breaching the vapor barrier (if installed), repairs should be implemented to properly seal the barrier breach and, if necessary, repair cut or damaged sections of sub-slab components of the venting system or post-slab vapor barrier. An appropriately qualified and manufacturer-certified contractor must conduct the repair to the post-slab engineered vapor barrier.

A Site-Specific Health and Safety Plan (SSHSP) must be prepared for any such work. The SSHSP must include appropriate provisions for monitoring of indoor air for VOCs, for adequate ventilation of the work area, and any other necessary safety measures. The SSHSP should be provided to the Owner or Designated Responsible Party for review and approval prior to the work. All breaches or significant modifications to the VIMS must be approved in writing by the Owner or Designated Responsible Party. Approvals shall be kept in the log book.

A Professional Engineer registered in the State of California and specializing in the design of such systems shall be retained to provide a work plan, design drawings and specifications, and/or other necessary engineering design documents for any extensive repairs or significant alterations to the VIMS. The record drawings will be revised to reflect changes in the VIMS and kept in the logbook.

6.2.5 Annual Review

As noted above, the Owner or Designated Responsible Party will prepare an annual summary of its inspections for submittal to the ACDEH. The annual summary will include an evaluation of the VIMS effectiveness, any deficiencies noted, and proposed repairs in the case deficiencies are observed. The annual

summary will also include a recommendation for continued O&M or cessation of the VIMS operation, as appropriate. The annual summary will be provided to the ACDEH no later than February 15 of the calendar year following the reporting period.

6.2.6 Measures for the Termination of Long Term O&M

At any time, the termination of long term O&M requirements can be proposed as warranted by the operational data. At a minimum, every five years the need for long term O&M will be reviewed. Justification for ceasing long term O&M requirements may include:

- Collecting representative soil gas samples showing that COPC concentrations have been reduced to levels below levels of concern.
- Documentation that the inspections and performance measures have not shown a reduction in operational performance of the VIMS and that notification procedures are sufficient.

6.2.7 Event Response

In the event of a fire, earthquake, or other occurrence with the potential to damage the VIMS, the VIMS shall be inspected for damage and evaluated for necessary repairs.

7.0 REPORTING AND SCHEDULE

This section presents a preliminary schedule and a description of the documentation and reporting of the VIMS installation and associated activities.

7.1 Documentation and Reporting

Project documentation involves recordkeeping and reporting associated with the VIMS installation and sub-slab gas monitoring for contingency actions. During installation of the SSV piping and moisture vapor barrier, Pangea and/or the VIMS Design Engineer will inspect and document installation.

Following certification of the SSV system, performance monitoring/vent riser sampling will commence for the VIMS. After soil gas testing of the SSV riser piping, Pangea will prepare brief reports documenting sampling procedures and results.

A Post-Construction Site Management Plan (SMP) will be prepared following completion of VIMS installation, construction, and testing. The Post-Construction SMP will include a Record Report of Construction (As-Builts for VIMS, trench plugs, etc), final O&M plans, tenant notifications (Proposition 65), and deed restriction (if required). The SMP will also include a certification from the CQM manager and

VIMS Design Engineer that the completed project conforms to the construction documents. The schedule for project documentation is shown below in Table D.

7.2 Preliminary Scheduling

The anticipated schedule for the activities described in this Design Basis Report is presented below in Table D. This schedule is approximate, and the actual dates will depend on the timing and acquisition of agency approval, applicable permits, subcontractor availability, and field conditions.

Table D – Tentative VIMS Schedule for Buildings 1 thru 4

Date	Action	Responsible Entity
November 23, 2016	VIMS Design Drawing Submittal	VIMS Design Engineer
November 29, 2016	Design Basis Report Submittal	Pangea/VIMS Design Engineer
Early December 2016	Agency Approval of Design Basis Report	ACDEH
Early December 2016	SSV Installation and CQA	Contractor, VIMS Design Engineer
December 14, 2016	Pour Building Slabs (Buildings 1&2)	Contractor
Dec 2016-April 2017	Building Construction	Contractor
Early January 2017	SSV Riser Gas Sampling Event#1/Report	Pangea
Early February 2017	SSV Riser Gas Sampling Event#2/Report	Pangea
Feb-Mar 2017	Install Contingent Post-Slab Engineered Vapor Barrier, if Needed	Specialty Contractor
Late March 2017	Final Floor Finishes	Contractor
March-April 2017	Agency Comfort Letter	ACDEH
March 2017	SSV Riser Gas Sampling Event#3/Report	Pangea
April 2017	Building Ready for Occupancy/Sale	Owner
April 2017	Indoor Air Sampling (if merited)	Pangea
April 2017	Convert SSV to Active, if Needed	Contractor
March-April 2017	Post-Construction SMP, VIMS Record Report of Construction and Certification, Final O&M Plan	
Early May 2017	No Further Action Letter	ACDEH
Ongoing	O&M Implementation, if Needed (Indoor Air Sample and Contingent Active SSD)	Owner, Pangea

8.0 REFERENCES

The regulatory record for this Site can be found on the State of California GeoTracker Website at http://geotracker.waterboards.ca.gov/profile_report.asp?global_id=T10000009292

DTSC, 2011. *Vapor Intrusion Mitigation Advisory (VIMA), Revision 1, Final*. October. https://dtsc.ca.gov/SiteCleanup/upload/VIMA_Final_Oct_20111.pdf

Los Angeles Department of Building and Safety (LADBS). Methane Mitigation Standards. <http://ladbs.org/services/core-services/plan-check-permit/methane-mitigation-standards>

PANGEA, 2016a, *Draft Corrective Action Plan*. October 7.

PANGEA, 2016b. *Interim Remediation Report*. October 26.

PANGEA, 2016c. *Data Gap Investigation Report, Buildings 3 & 4*. November 16.

SFRWQCB, 2016. San Francisco Bay Regional Water Quality Control Board, *Environmental Screening Levels*, February 22, (Revision 3, May)



1233 Bockman Road

**1233 Bockman Road
San Lorenzo, California**



Vicinity Map

**Figure
1**

0 2,000
Approximate Scale (in Feet)

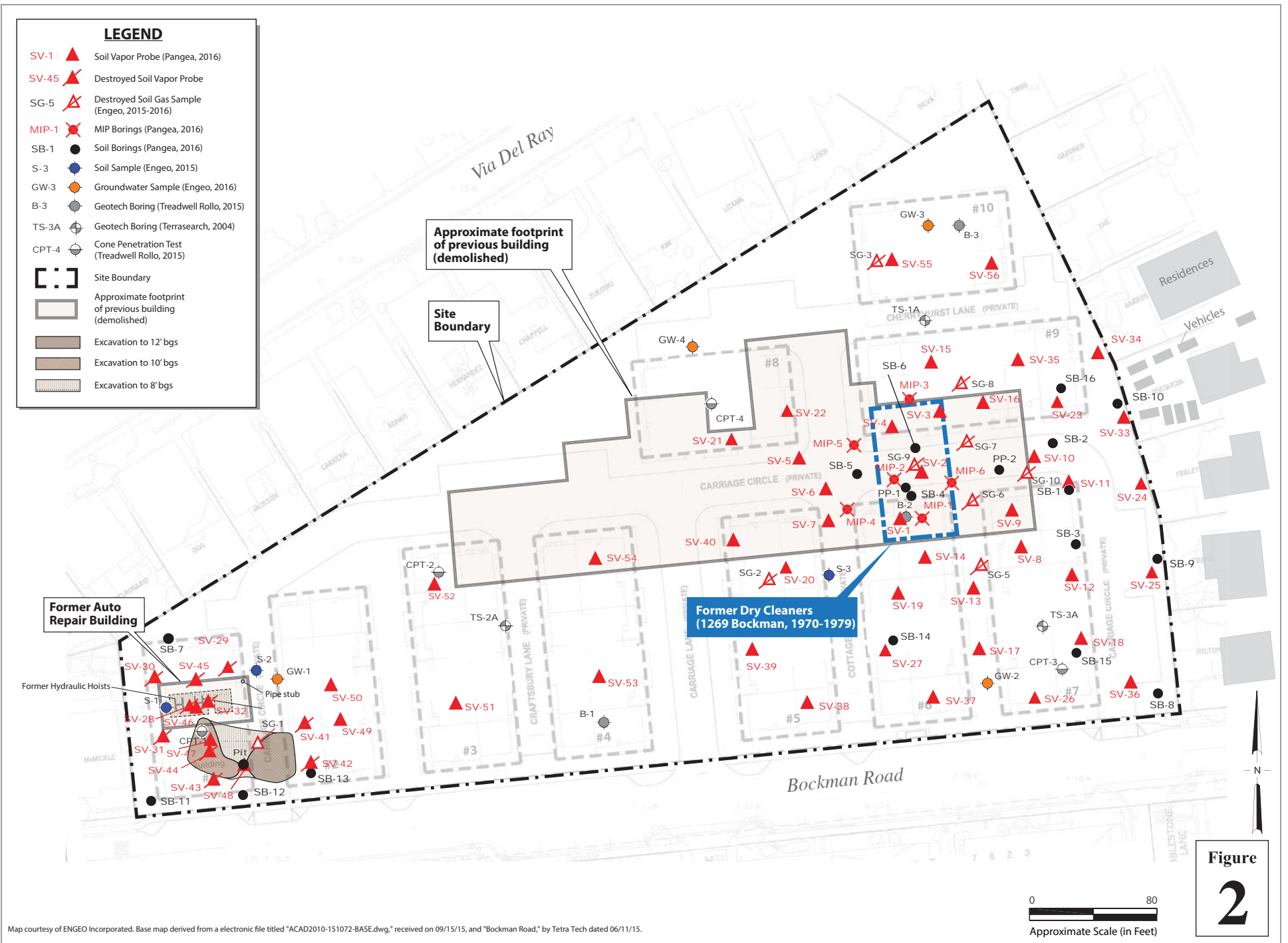

1233 Bockman Road
San Lorenzo, California



Figure
2

Site Map

Appendix A
Development Plans

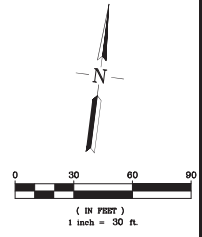
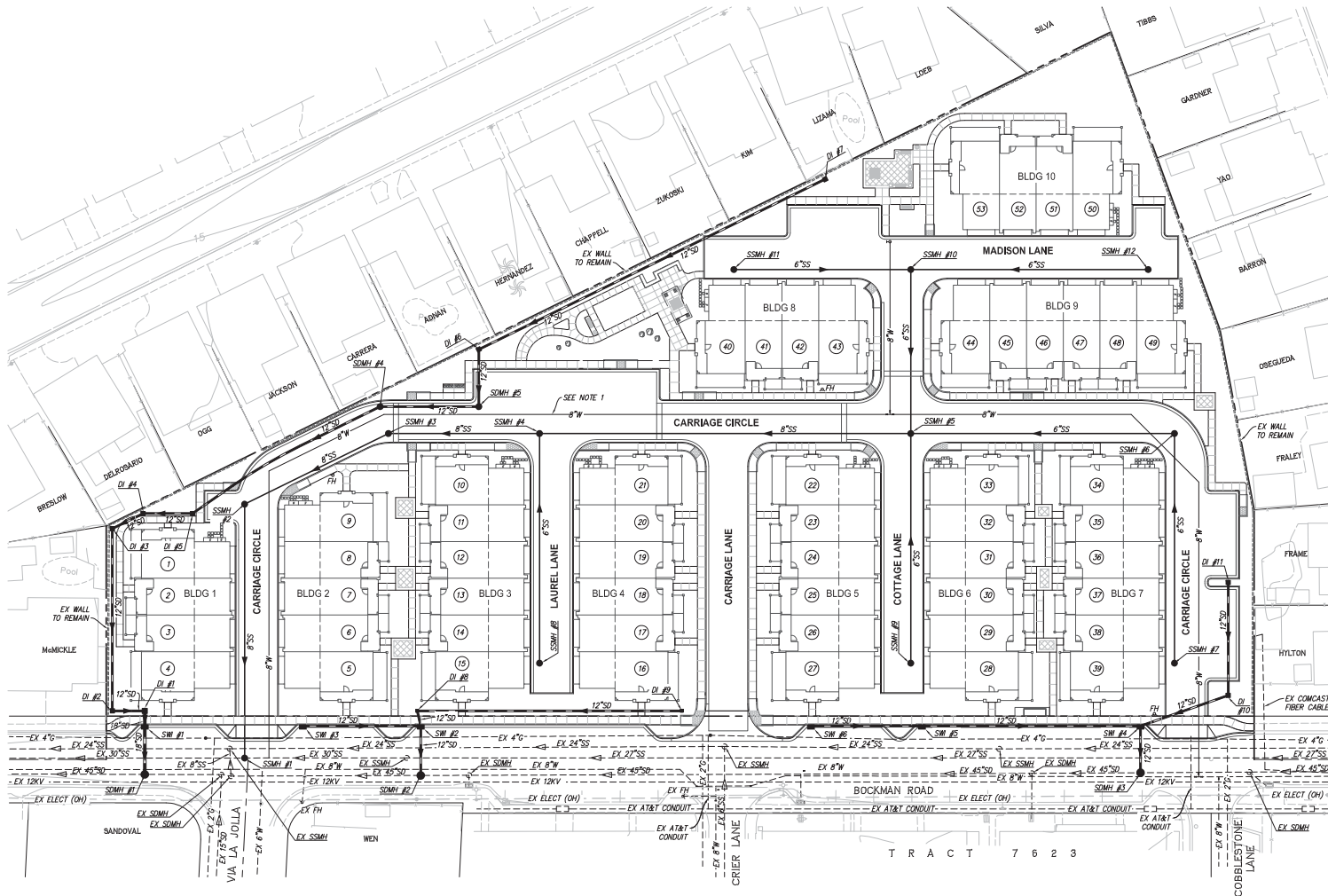

STORM DRAIN STRUCTURE SCHEDULE	
STRUCTURE NO.	STRUCTURE
SW #1, 2, 3, 4, 5, 6	DROP INLET WITHOUT TAPER PER COUNTY STD DETAIL SD-420
SSMH #1, 2	SHALLOW MANHOLE PER DETAIL 1/C2.5
SMH #3	MANHOLE TYPE II WITH MANHOLE FRAME AND COVER PER DETAILS SD-401 & SD-407
DI #1	OLDCASTLE PRECAST DROP INLET MODEL 2K (24"x24") WITH PEDESTRIAN FRAME & GRATE PER DETAIL 4/C2.4
DI #2, 3, 4, 5, 6, 7, 8, 9, 10, 11	OLDCASTLE PRECAST DROP INLET MODEL CK (18"x18") WITH PEDESTRIAN FRAME & GRATE PER DETAIL 4/C2.4

NOTES:
 1. 8" W MAIN AND FIRE HYDRANT (FH) ARE SHOWN FOR REFERENCE ONLY. SEE ERMAD PLANS FOR EXACT LOCATIONS AND DESIGN INFORMATION.
 2. ONLY SD PIPES 12" AND LARGER ARE SHOWN.

REVIEWED BY:
 FOR ALAMEDA COUNTY
 PUBLIC WORKS AGENCY

RJA
RUGGERI-JENSEN-AZAR
 ENGINEERS • PLANNERS • SURVEYORS
 4600 SAN LEONARDO AVENUE, SUITE 200
 SAN LEONARDO, CALIFORNIA 92570
 PHONE: (951) 272-8100 FAX: (951) 272-9300



IMPROVEMENT PLANS
 TRACT 8284 - THE BUNGALOWS
UTILITY SYSTEM MAP
 SAN LORENZO, ALAMEDA COUNTY, CALIFORNIA
 FOR: SAN LORENZO RES, LLC

DATE	BY	CHK	DTI	NO.	REV

SHEET NO.
C3.2
 10 OF 33 SHEETS
 JOB NO.
 151072

D:\WORK\151072\151072-03-CONSTRUCTION 2003\DWG\PLAN\UTILITY-IMPROVEMENTS 151072.DWG 1:50 BY RW/MLL

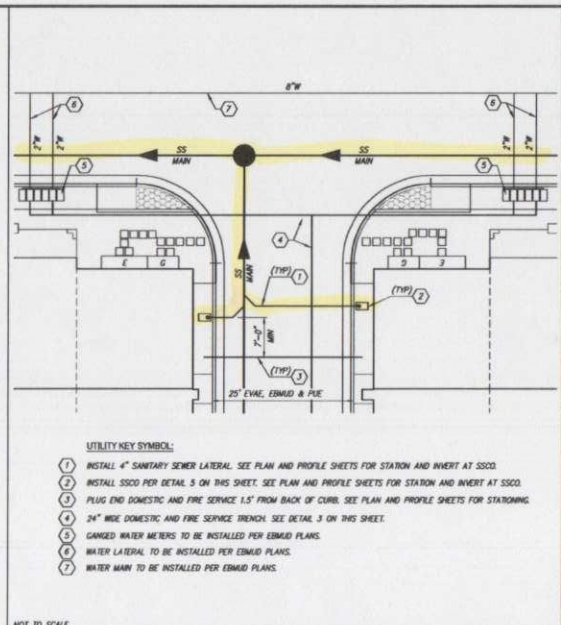
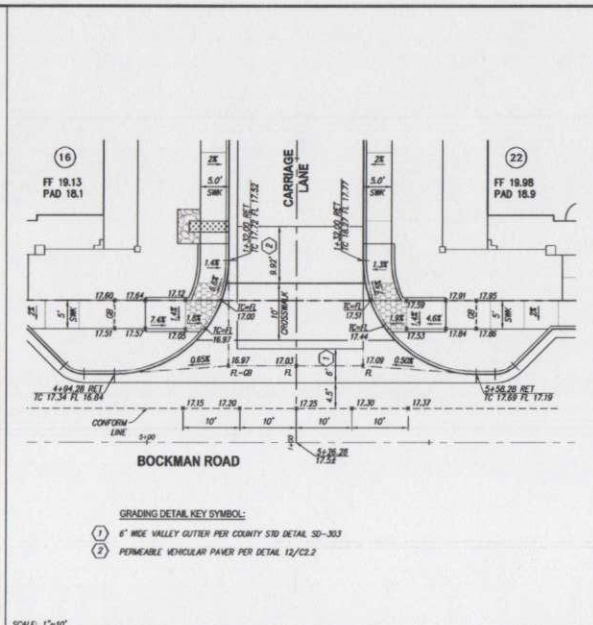
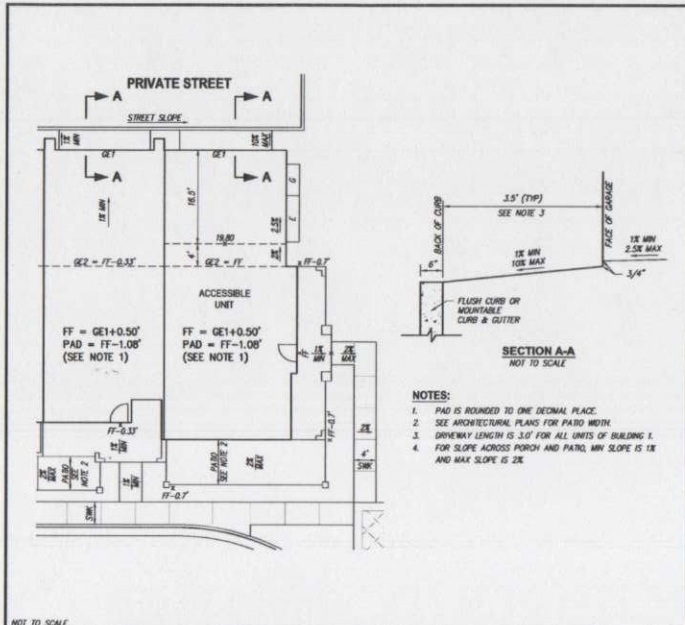

1 TYPICAL GRADING AT BUILDING UNITS

2 GRADING DETAIL AT INTERSECTION OF BOCKMAN RD & CARRIAGE LANE

3 TYPICAL UTILITY SERVICES FOR EACH BUILDING UNIT

Oldcastle Precast Water **Top Extension Drop Inlet** Model DROPM TOPEXT

TYPICAL SECTION

TOP EXTENSION TABLE

MODEL No.	SP. THICKNESS	A	B	C
		IN	MM	IN
CB212TE	2K	12	305	12
CB1818TE	2K	18	450	18
CB1824TE	1K	18	450	24
CB2424TE	2K	24	600	24
CB2430TE	3K	24	600	30
CB3030TE	4K	30	750	30
CB2436TE	1L	24	600	36
CB2436TE	1M	24	600	36
CB2448TE	3L	24	600	48
CB3648TE	3M	36	900	48
CB4848TE	1R	48	1200	48

NOTES:

- FRAMES AND GRATES MAY BE ORDERED WITH POLISHED OR ENGRAINED FINISHES. ALL FINISHES ARE SUBJECT TO PROOF. OPTIONAL GRATE LOCKING DEVICE AVAILABLE ON REQUEST. SEE DRAWING FOR FRAME 1L. GRATES WITH GRATES OR CAST IRON FRAME AND GRATES ARE AVAILABLE ON REQUEST.
- CHUBB PACS AND BUSHINGS OPTIONS AVAILABLE SEE DRAWING FOR FRAME 1L, 1M AND 1R.
- FRAMES AND GRATES DETAIL BSA PAGES 1-A, 1-B, AND 1-C.
- WALL THICKNESS ON ALL D.I.E. CAN BE CHANGED UPON REQUEST.
- IF WITH 0.15" SPACED 1" X 1" 1/2" WEB WORK & IE.
- ADA AND IBC PROOF FRAME AND GRATES ARE AVAILABLE ON REQUEST.

WATER SERVICE TRENCH

NOTES:

- SEE EMBUD STD DETAIL 1992-A FOR COMPACTION REQUIREMENTS
- CLASS 2 ASH QUANTITY FINES OR DRAIN ROCK
- CLASS 2 ASH OR QUARRY FINES

SANITARY CLEANOUT AND OVERFLOW

NOTES:

- SEE ORO LOWA SANITARY DISTRICT STD DETAILS 50-11 AND 50-15 FOR ADDITIONAL INFORMATION.

4 DROP INLET

5 WATER SERVICE TRENCH

6 SANITARY CLEANOUT AND OVERFLOW

RJA
RUGGERI-JENSEN-AZAR
P.O. BOX 1000
4800 CHERRY DRIVE, SUITE 200
PLEASANTON, CA 94588
PHONE: (925) 227-7000 FAX: (925) 227-3500

IMPROVEMENT PLANS
TRACT 8284 - THE BUNGALOWS
DETAILS
SAM LORENZO, ALAMEDA COUNTY, CALIFORNIA
SAN LORENZO RES, LLC
FOR: SAM LORENZO RES, LLC

SCALE	DATE	BY	CHK	APP	REV
1"=10'	11-17-2016	AL/WW/PP			

REVIEWED BY:
FOR ALAMEDA COUNTY PUBLIC WORKS AGENCY

SHEET NO. **C2.4**
7 of 33 SHEETS
JOB NO. 151072

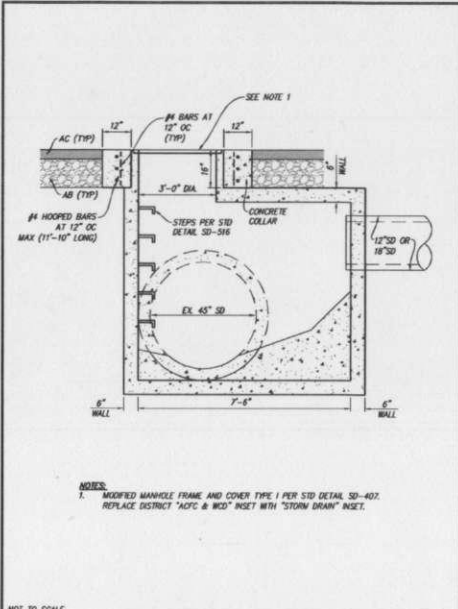

1 SHALLOW STORM DRAIN MANHOLE

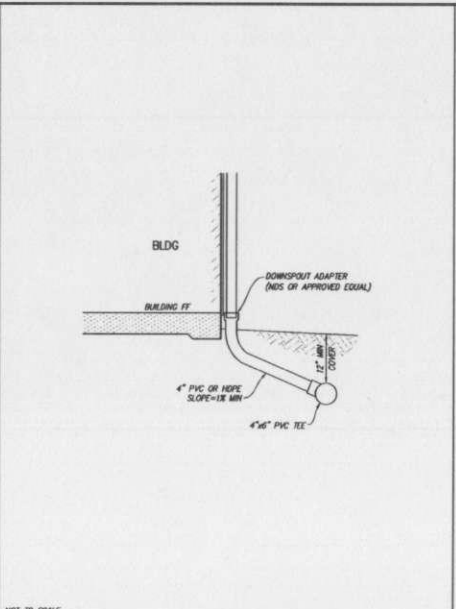

2 DOWNSPOUT CONNECTION TO AREA DRAIN LATERAL

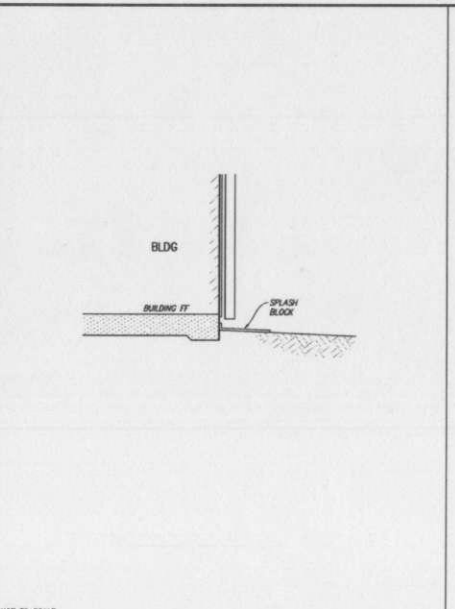

3 DOWNSPOUT WITH SPLASH BLOCK

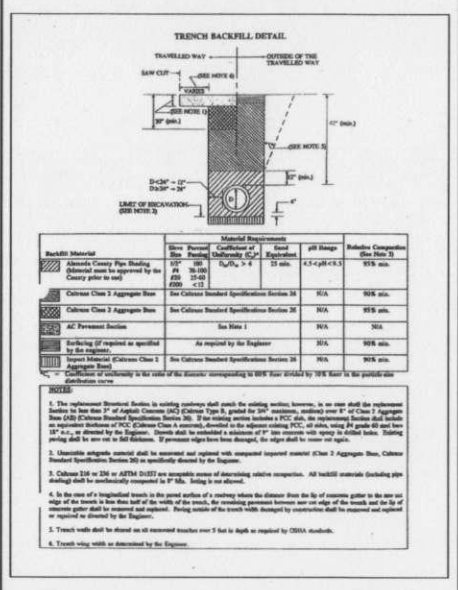

4 STORM DRAIN TRENCH BACKFILL DETAIL

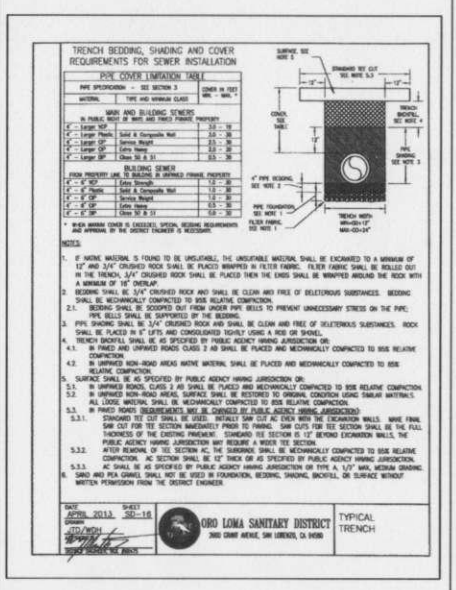

5 SANITARY SEWER TRENCH BACKFILL DETAIL

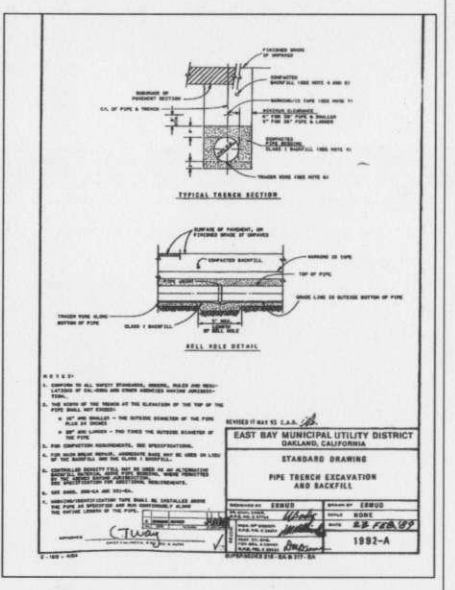

6 WATER TRENCH BACKFILL DETAIL

RJA
RUGGERI-JENSEN-AZAR
 840 COLLEGE AVENUE, SUITE 200 • FLEMINGTON, CA 94988
 (707) 922-7900 • FAX: (707) 271-3500



IMPROVEMENT PLANS
 TRACT 8284 - THE BUNGALOWS
DETAILS
 SAN LORENZO, ALAMEDA COUNTY, CALIFORNIA
 FOR: SAN LORENZO RES. LLC

DATE	BY	CHK	APP	DESCRIPTION
1-17-2013				DESIGNED
				CHECKED
				APPROVED

REVIEWED BY:
 FOR ALAMEDA COUNTY
 PUBLIC WORKS AGENCY

SHEET NO.
C2.5
 8 of 33 SHEETS
 151072

Appendix B

Vapor Intrusion Mitigation System (VIMS) Design Drawings

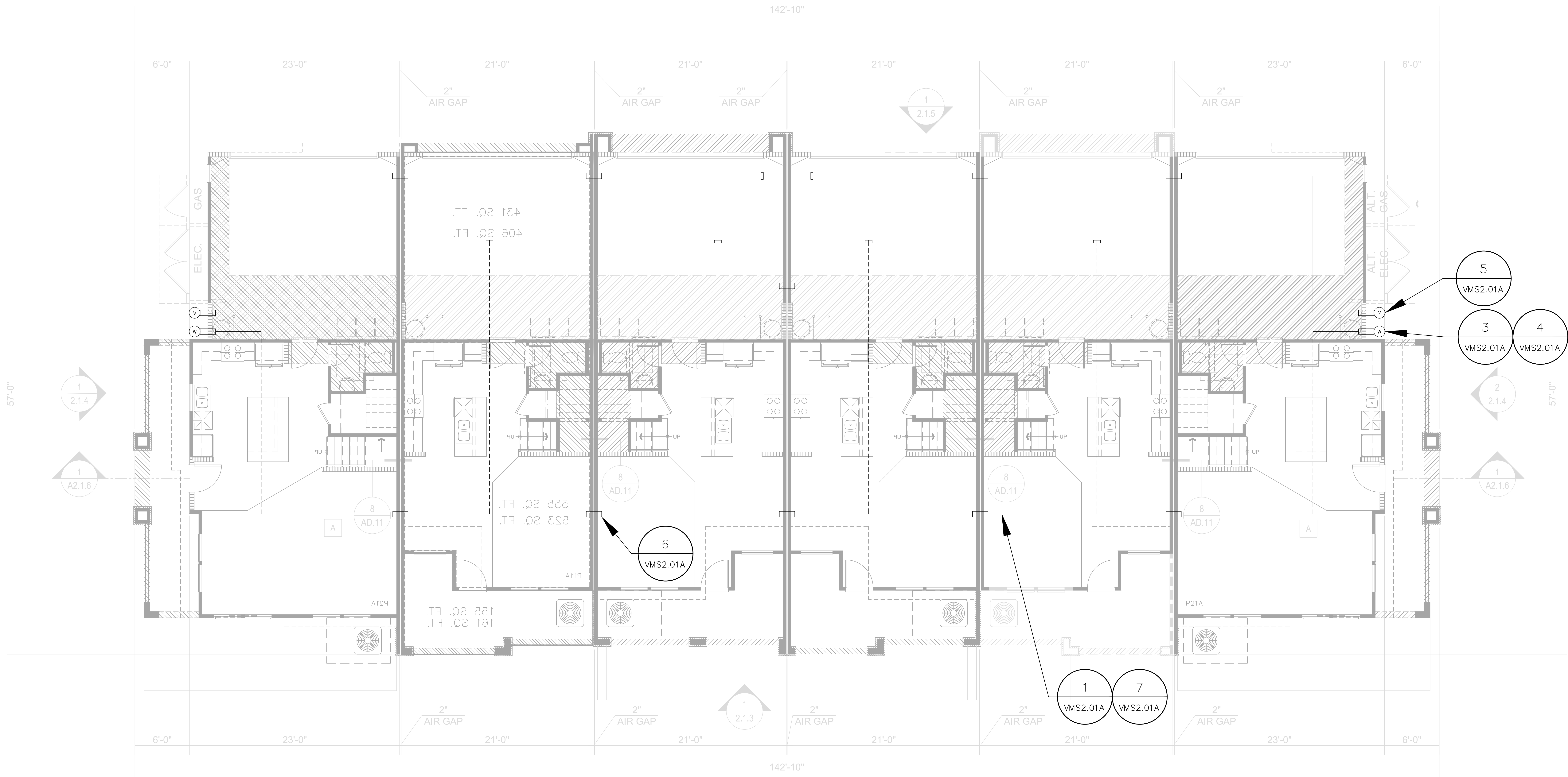

SYMBOLS LEGEND

- 3" DIAMETER PERFORATED SCH. 40 PVC PIPE BELOW SLAB (SEE DETAILS ON SHEET VMS2.01A)
- [] 3" DIAMETER PVC PIPE END CAP
- 3" DIAMETER SOLID SCH. 40 PVC PIPE BELOW SLAB
- 4" DIAMETER SOLID PVC PIPE SLEEVE
- (V) PERIMETER INLET VENT (SEE DETAILS ON SHEET VMS2.01A)
- (W) CIP OR DIP RISER PIPE TO ROOF (SEE DETAILS ON SHEET VMS2.01A)
- (1 VMS2.01A) SEE DETAIL 1, SHEET VMS2.01A

GENERAL NOTES

1. SYMBOLS NOT TO SCALE.

GRAPHIC SCALE

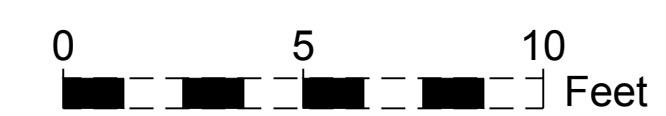

Date	Description	No.
11/21/16	SUBMITTAL TO ALAMEDA COUNTY	1
REVISIONS		
SIGNATURE	DATE SIGNED	
LANGAN 305 Montgomery Street, Suite 1300, San Francisco, CA 94111 T: 415.955.5200 F: 415.955.5201 www.langan.com NEW JERSEY NEW YORK CONNECTICUT PENNSYLVANIA OHIO MASSACHUSETTS ILLINOIS TEXAS NORTH CAROLINA CALIFORNIA MISSOURI ARIZONA IDAHO OREGON WASHINGTON PANAMA Langan Engineering & Constructors, Inc. is an Equal Opportunity Employer Langan Engineering and Constructors Services, Inc. 10000 Wilshire Blvd., Suite 1000 Culver City, CA 90230		
Project		
THE BUNGALOWS		
SAN LORENZO	BOCKMAN DRIVE	CALIFORNIA
Drawing Title		
VAPOR MITIGATION PLAN BUILDING TYPE A INITIAL CONSTRUCTION		
Project No.	770625803	Drawing No.
Date	11/02/16	MT1.01A
Scale	Not to Scale	
Drawn By	HB	Checked By
Submission Date	11/21/16	Sheet 1 of 8

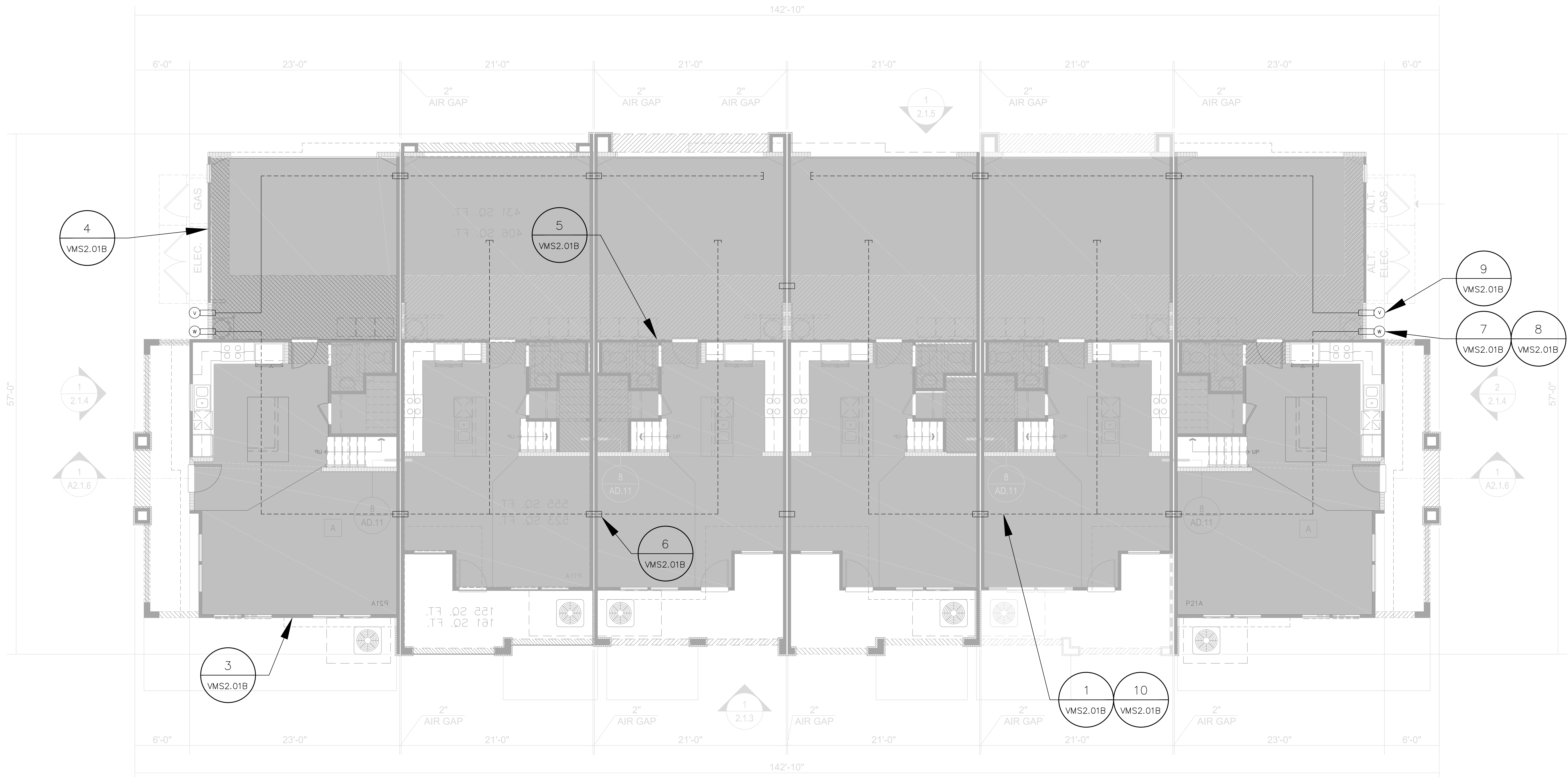

SYMBOLS LEGEND

- 3" DIAMETER PERFORATED SCH. 40 PVC PIPE BELOW SLAB (SEE DETAILS ON SHEET VMS2.01B)
- 3" DIAMETER PVC PIPE END CAP
- 3" DIAMETER SOLID SCH. 40 PVC PIPE BELOW SLAB
- 4" DIAMETER SOLID PVC PIPE SLEEVE
- Ⓧ PERIMETER INLET VENT (SEE DETAILS ON SHEET VMS2.01B)
- Ⓦ CIP OR DIP RISER PIPE TO ROOF (SEE DETAILS ON SHEET VMS2.01B)
- ① VMS2.01B SEE DETAIL 1, SHEET VMS2.01B
- RETROCOAT (SEE DETAILS ON SHEET VMS2.01B)

GENERAL NOTES

1. SYMBOLS NOT TO SCALE.

GRAPHIC SCALE

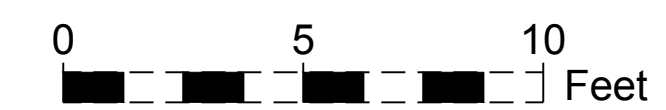

Date	Description	No.
11/21/16	SUBMITTAL TO ALAMEDA COUNTY	1
REVISIONS		
 SIGNATURE: _____ DATE SIGNED: _____ PROFESSIONAL ENGINEER STATE LIC. No. 69777		
LANGAN <small>305 Montgomery Street, Suite 1300, San Francisco, CA 94111 T: 415.955.5200 F: 415.955.5201 www.langan.com</small> <small>NEW JERSEY NEW YORK CONNECTICUT PENNSYLVANIA OHIO MASSACHUSETTS ILLINOIS TEXAS NORTH CAROLINA CALIFORNIA MISSOURI ARIZONA IDAHO OREGON WASHINGTON</small> <small>Langan Engineering, Consulting, & Construction, Inc. is an Equal Opportunity Employer Langan Engineering and Construction Services, Inc. Langan Construction Services, Inc. Langan Environmental Services, Inc.</small>		
Project		
THE BUNGALOWS		
SAN LORENZO BOCKMAN DRIVE CALIFORNIA		
Drawing Title		
VAPOR MITIGATION PLAN BUILDING TYPE A WITH POST-CONSTRUCTION RETROCOAT		
Project No.	770625803	Drawing No.
Date	11/02/16	MT1.01B
Scale	Not to Scale	
Drawn By	HB	Checked By
Submission Date	11/21/16	SR
		Sheet 2 of 8

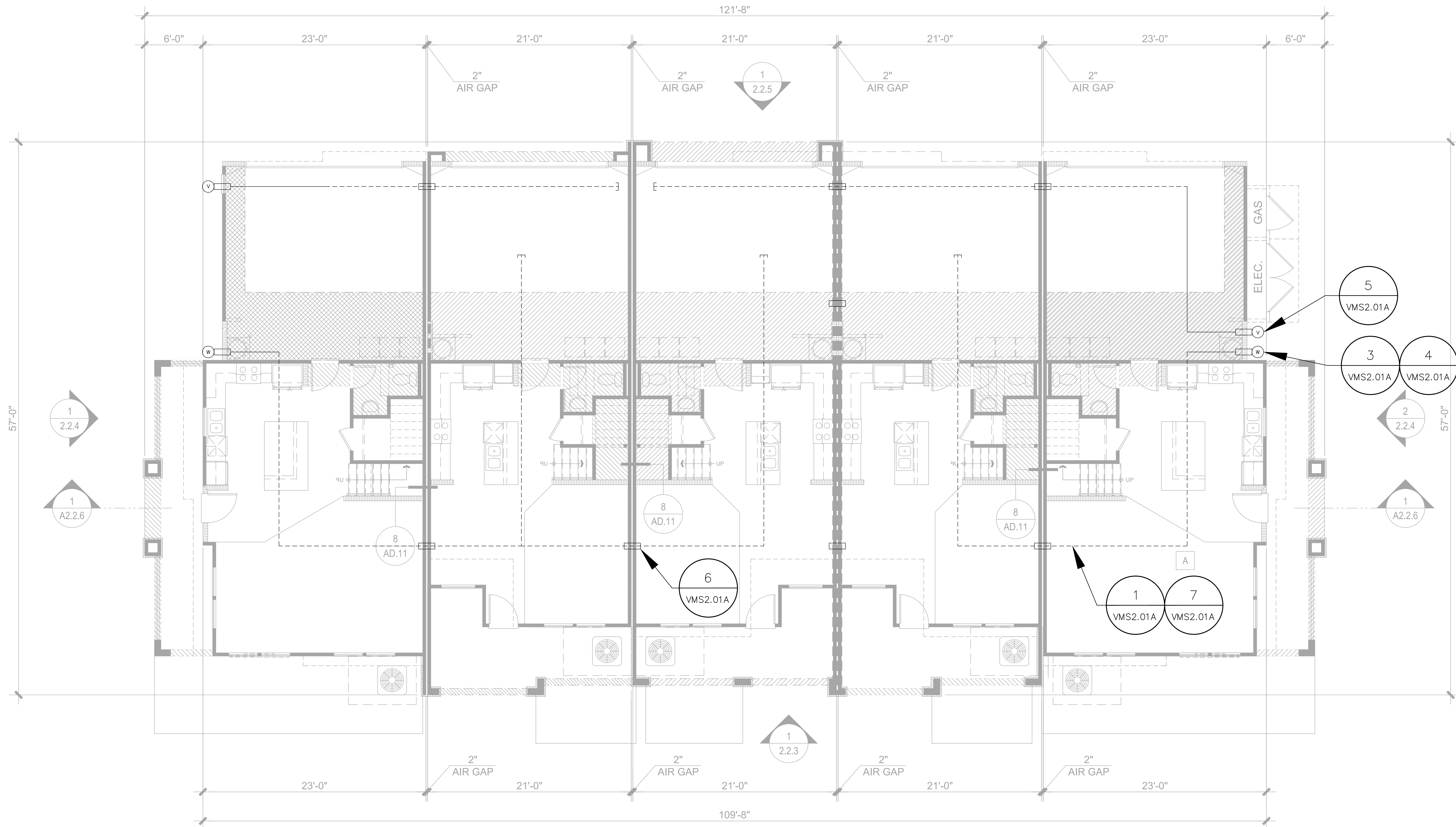

SYMBOLS LEGEND

- 3" DIAMETER PERFORATED SCH. 40 PVC PIPE BELOW SLAB (SEE DETAILS ON SHEET VMS2.01A)
- [] 3" DIAMETER PVC PIPE END CAP
- 3" DIAMETER SOLID SCH. 40 PVC PIPE BELOW SLAB
- 4" DIAMETER SOLID PVC PIPE SLEEVE
- (V) PERIMETER INLET VENT (SEE DETAILS ON SHEET VMS2.01A)
- (W) CIP OR DIP RISER PIPE TO ROOF (SEE DETAILS ON SHEET VMS2.01A)
- (1 VMS2.01A) SEE DETAIL 1, SHEET VMS2.01A

GENERAL NOTES

1. SYMBOLS NOT TO SCALE.

GRAPHIC SCALE

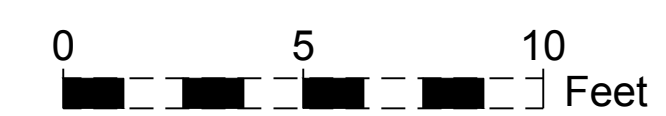

Date	Description	No.
11/21/16	SUBMITTAL TO ALAMEDA COUNTY	1

REVISIONS



SIGNATURE: [Signature] DATE SIGNED: [Date]
 PROFESSIONAL ENGINEER
 STATE LIC. No. 69777

LANGAN
 305 Montgomery Street, Suite 1300, San Francisco, CA 94111
 T: 415.955.5200 F: 415.955.5201 www.langan.com
 NEW JERSEY NEW YORK CONNECTICUT PENNSYLVANIA OHIO
 MASSACHUSETTS ILLINOIS TEXAS MICHIGAN CALIFORNIA
 MISSOURI ARIZONA IDAHO OREGON WASHINGTON
 Langan Engineering, Consulting, & Construction, Inc. is an Equal Opportunity Employer. Minorities and women are encouraged to apply.

Project: **THE BUNGALOWS**

SAN LORENZO BOCKMAN DRIVE CALIFORNIA
 Drawing Title

**VAPOR MITIGATION PLAN
 BUILDING TYPE B
 INITIAL CONSTRUCTION**

Project No.	770625803	Drawing No.	MT1.02A
Date	11/02/16	Scale	Not to Scale
Drawn By	HB	Checked By	SR
Submission Date	11/21/16	Sheet	3 of 8

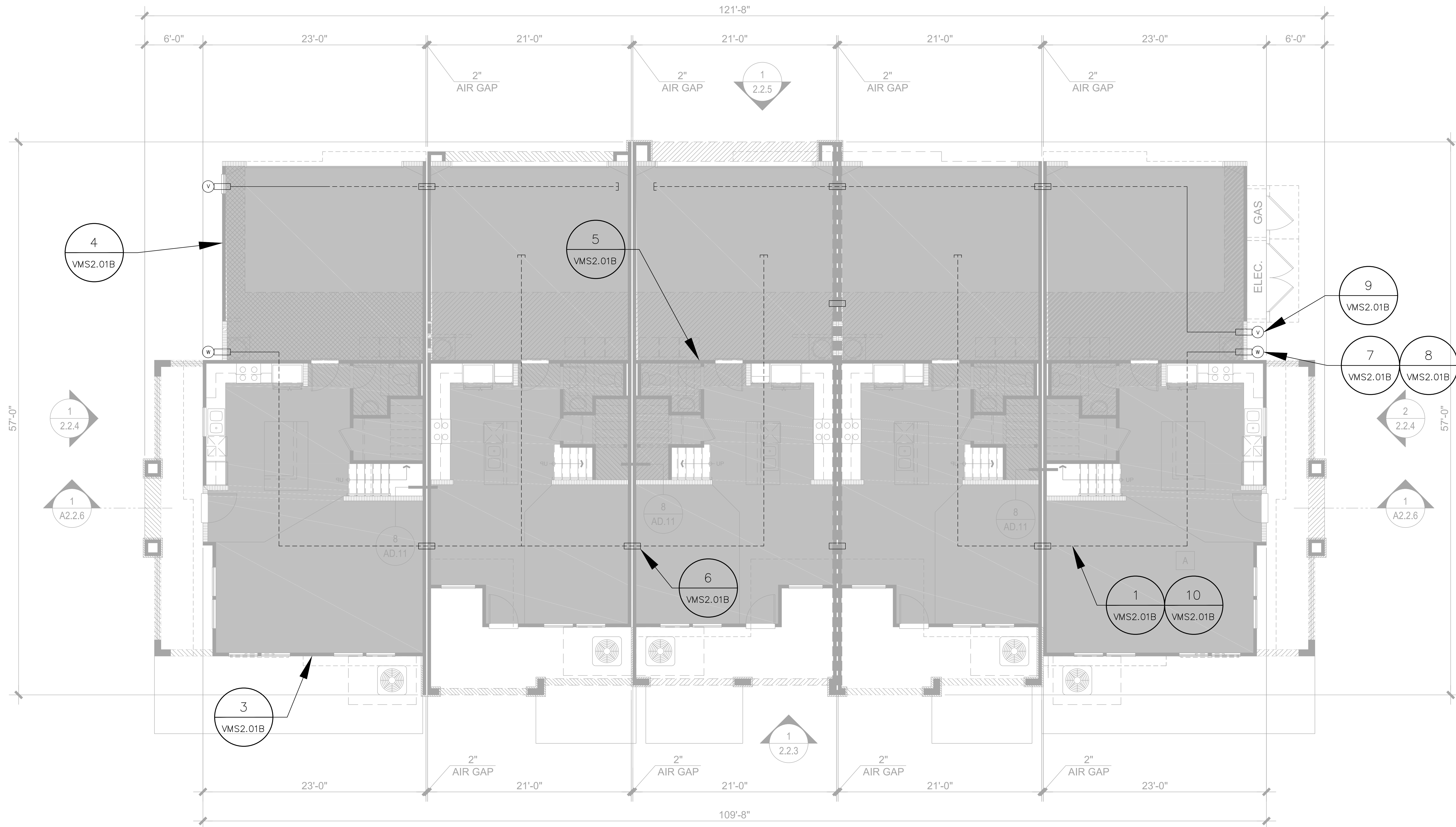

SYMBOLS LEGEND

- 3" DIAMETER PERFORATED SCH. 40 PVC PIPE BELOW SLAB (SEE DETAILS ON SHEET VMS2.01B)
- [] 3" DIAMETER PVC PIPE END CAP
- 3" DIAMETER SOLID SCH. 40 PVC PIPE BELOW SLAB
- 4" DIAMETER SOLID PVC PIPE SLEEVE
- (V) PERIMETER INLET VENT (SEE DETAILS ON SHEET VMS2.01B)
- (W) CIP OR DIP RISER PIPE TO ROOF (SEE DETAILS ON SHEET VMS2.01B)
- (1) SEE DETAIL 1, SHEET VMS2.01B
- RETROCOAT (SEE DETAILS ON SHEET VMS2.01B)

GENERAL NOTES

1. SYMBOLS NOT TO SCALE.

GRAPHIC SCALE

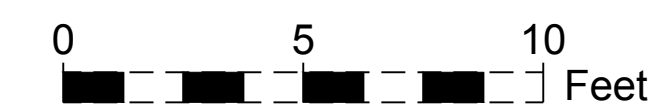

Date	Description	No.
11/21/16	SUBMITTAL TO ALAMEDA COUNTY	1

REVISIONS



SIGNATURE: [Signature] DATE SIGNED: [Date]
 PROFESSIONAL ENGINEER
 STATE LIC. No. 69777

LANGAN
 305 Montgomery Street, Suite 1300, San Francisco, CA 94111
 T: 415.955.5200 F: 415.955.5201 www.langan.com
 NEW JERSEY NEW YORK CONNECTICUT PENNSYLVANIA OHIO
 MASSACHUSETTS ILLINOIS TEXAS MICHIGAN CALIFORNIA
 MISSOURI ARIZONA IDAHO OREGON WASHINGTON
 Langan Engineering and Architecture, Inc.
 Langan Engineering and Architecture, Inc.
 Langan Engineering and Architecture, Inc.

Project: **THE BUNGALOWS**

San Lorenzo Bockman Drive California
 Drawing Title: **VAPOR MITIGATION PLAN
 BUILDING TYPE B
 WITH POST-CONSTRUCTION
 RETROCOAT**

Project No.	770625803	Drawing No.	MT1.02B
Date	11/02/16	Scale	Not to Scale
Drawn By	HB	Checked By	SR
Submission Date	11/21/16	Sheet	4 of 8

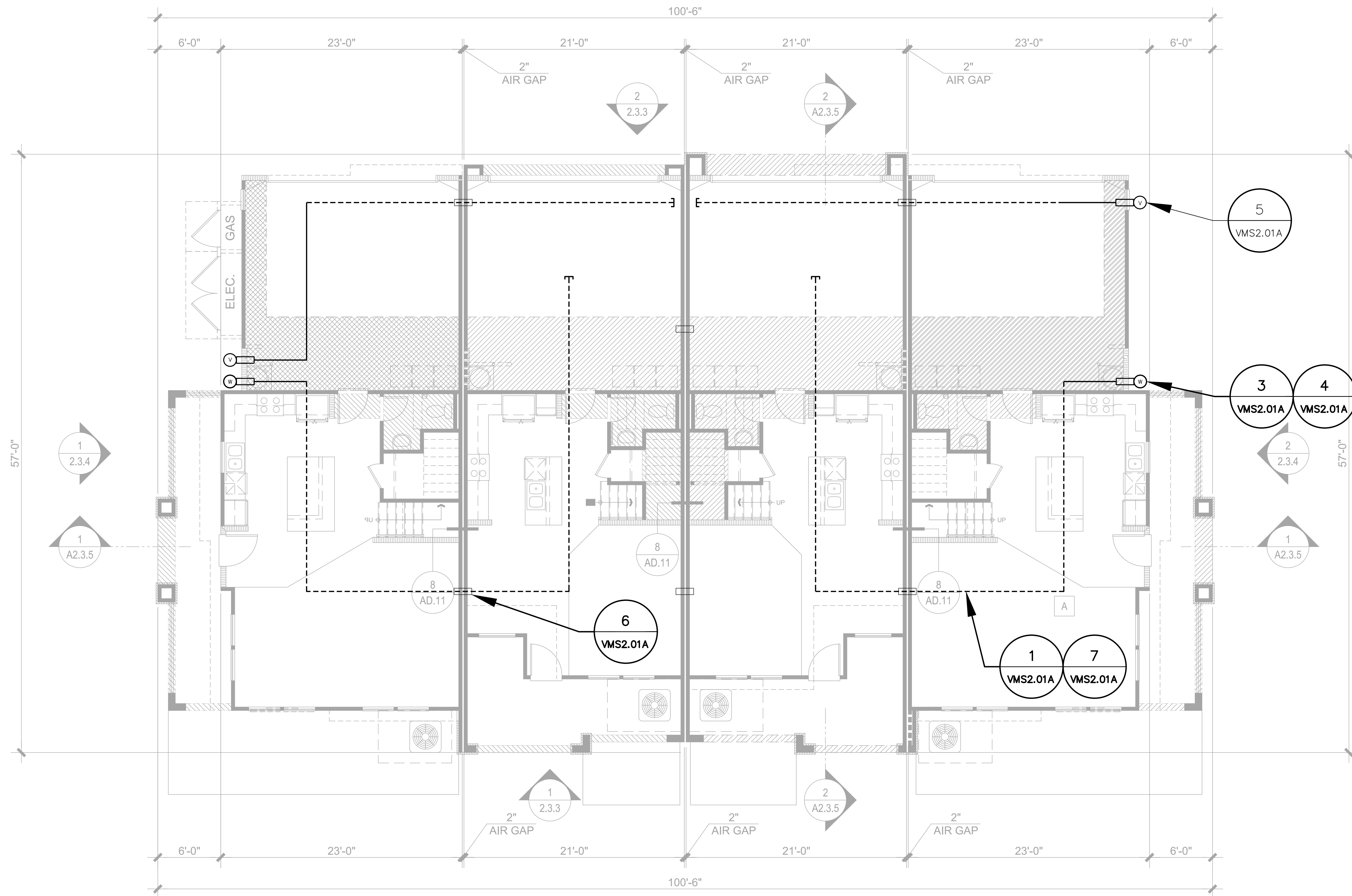

SYMBOLS LEGEND

- 3" DIAMETER PERFORATED SCH. 40 PVC PIPE BELOW SLAB (SEE DETAILS ON SHEET VMS2.01A)
- [] 3" DIAMETER PVC PIPE END CAP
- 3" DIAMETER SOLID SCH. 40 PVC PIPE BELOW SLAB
- 4" DIAMETER SOLID PVC PIPE SLEEVE
- (V) PERIMETER INLET VENT (SEE DETAILS ON SHEET VMS2.01A)
- (W) CIP OR DIP RISER PIPE TO ROOF (SEE DETAILS ON SHEET VMS2.01A)
- (1/VMS2.01A) SEE DETAIL 1, SHEET VMS2.01A

GENERAL NOTES

1. SYMBOLS NOT TO SCALE.

GRAPHIC SCALE

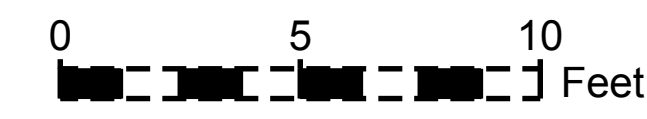

Date	Description	No.
11/21/16	SUBMITTAL TO ALAMEDA COUNTY	1

REVISIONS



SIGNATURE: [Signature] DATE SIGNED: [Date]
 PROFESSIONAL ENGINEER
 STATE LIC. NO. 69777

LANGAN

305 Montgomery Street, Suite 1300, San Francisco, CA 94111
 T: 415.955.5200 F: 415.955.5201 www.langan.com
 NEW JERSEY NEW YORK CONNECTICUT PENNSYLVANIA OHIO
 MASSACHUSETTS ILLINOIS TEXAS MICHIGAN CALIFORNIA
 MISSOURI ARIZONA IDAHO OREGON WASHINGTON
 Langan Engineering and Constructors, Inc. is an Equal Opportunity Employer
 Langan Engineering and Constructors, Inc.
 11/21/16

Project: THE BUNGALOWS

SAN LORENZO BOCKMAN DRIVE CALIFORNIA
 Drawing Title

VAPOR MITIGATION PLAN
 BUILDING TYPE C
 INITIAL CONSTRUCTION

Project No. 770625803	Drawing No. MT1.03A
Date 11/02/16	Scale Not to Scale
Drawn By HB	Checked By SR
Submission Date 11/21/16	Sheet 5 of 8

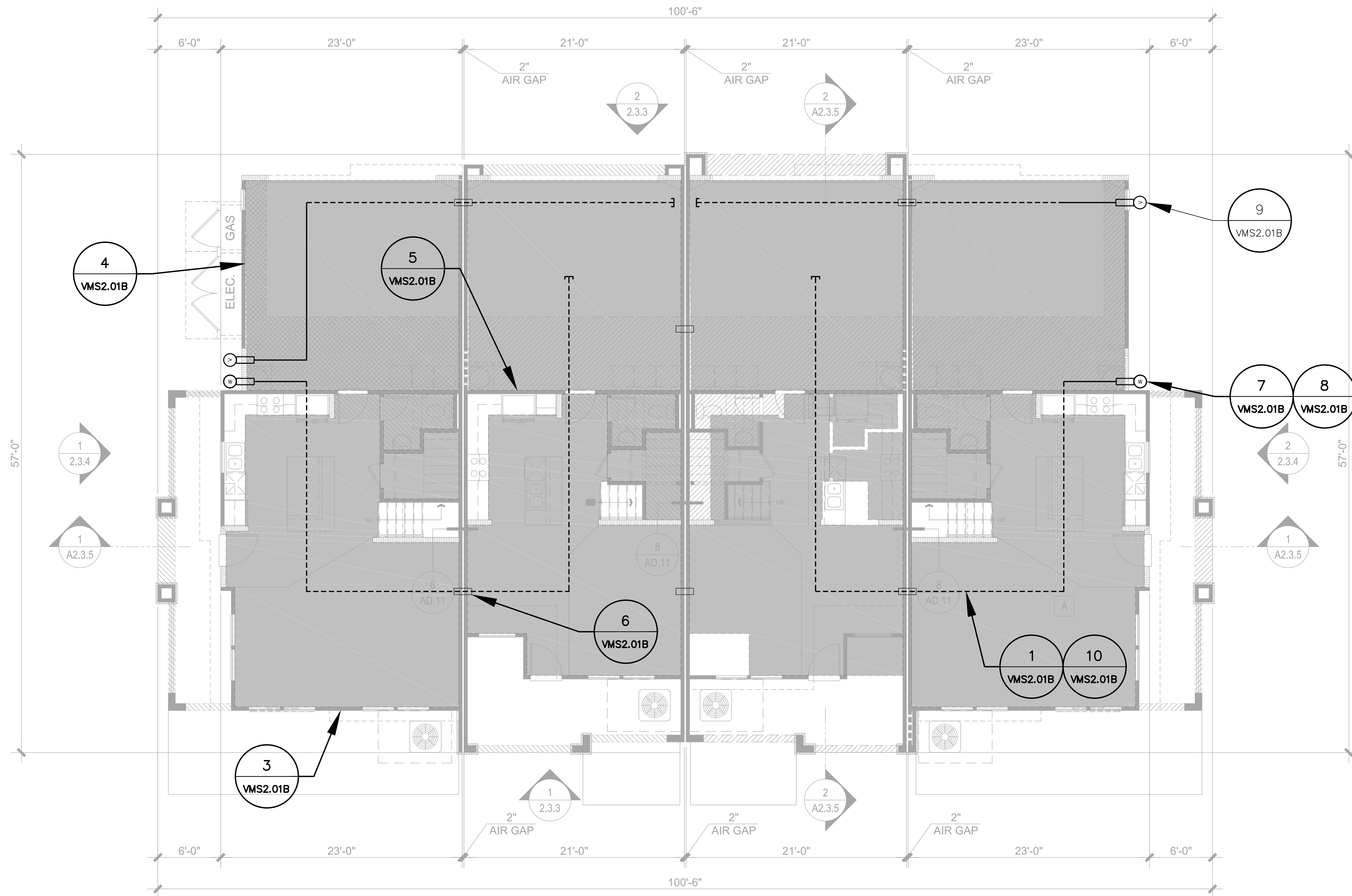

SYMBOLS LEGEND

- 3" DIAMETER PERFORATED SCH. 40 PVC PIPE BELOW SLAB (SEE DETAILS ON SHEET VMS2.01B)
- [] 3" DIAMETER PVC PIPE END CAP
- 3" DIAMETER SOLID SCH. 40 PVC PIPE BELOW SLAB
- 4" DIAMETER SOLID PVC PIPE SLEEVE
- (V) PERIMETER INLET VENT (SEE DETAILS ON SHEET VMS2.01B)
- (W) CIP OR DIP RISER PIPE TO ROOF (SEE DETAILS ON SHEET VMS2.01B)
- (1) SEE DETAIL 1, SHEET VMS2.01A
- RETROCOAT (SEE DETAILS ON SHEET VMS2.01B)

GENERAL NOTES

1. SYMBOLS NOT TO SCALE.

GRAPHIC SCALE

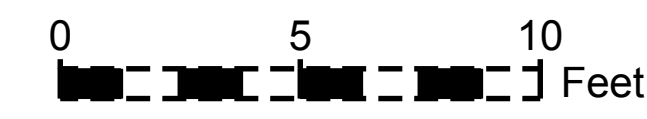

Date	Description	No.
11/21/16	SUBMITTAL TO ALAMEDA COUNTY	1

REVISIONS

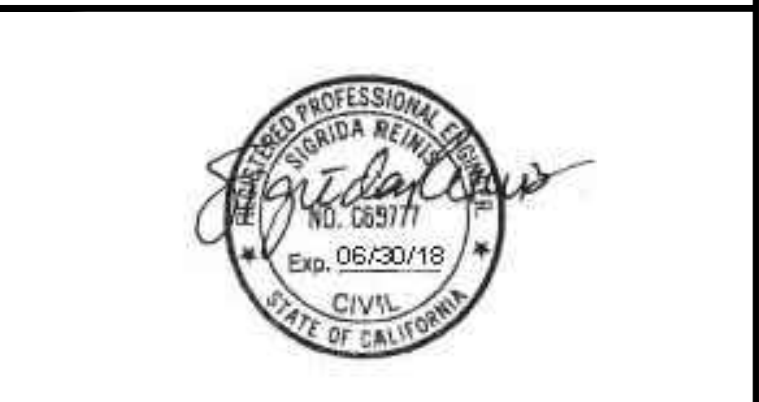

SIGNATURE: [Signature] DATE SIGNED: [Blank]
 PROFESSIONAL ENGINEER
 STATE LIC. NO. 69777

LANGAN
 305 Montgomery Street, Suite 1300, San Francisco, CA 94111
 T: 415.955.5200 F: 415.955.5201 www.langan.com
 NEW JERSEY NEW YORK CONNECTICUT PENNSYLVANIA OHIO
 MASSACHUSETTS ILLINOIS TEXAS MICHIGAN CALIFORNIA
 MISSOURI ARIZONA IDAHO OREGON WASHINGTON
 Langan Engineering and Architecture, Inc. is an Equal Opportunity Employer. Minorities and women are encouraged to apply.

Project: **THE BUNGALOWS**

Location: **SAN LORENZO BOCKMAN DRIVE CALIFORNIA**

Drawing Title: **VAPOR MITIGATION PLAN BUILDING TYPE C WITH POST-CONSTRUCTION RETROCOAT**

Project No.	770625803	Drawing No.	MT1.03B
Date	11/02/16	Scale	Not to Scale
Drawn By	HB	Checked By	SR
Submission Date	11/21/16	Sheet	6 of 8

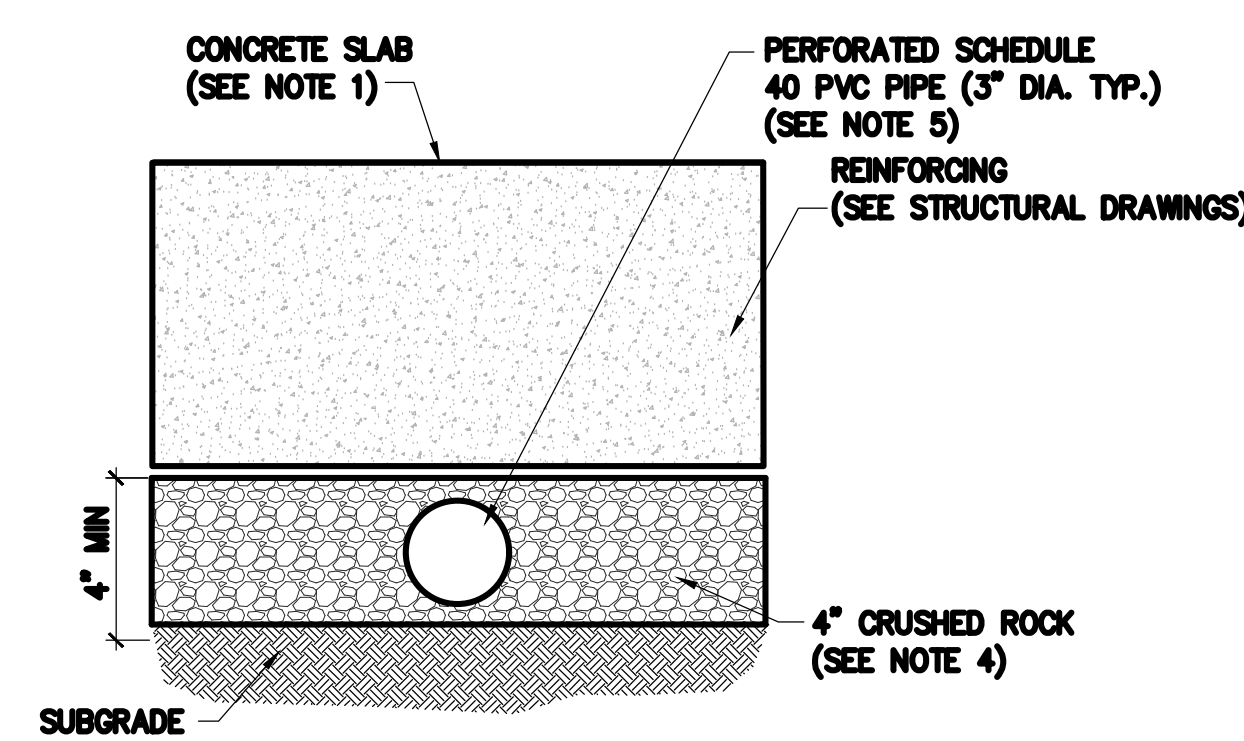

1 TYPICAL VAPOR MITIGATION SYSTEM CROSS-SECTION
NOT TO SCALE

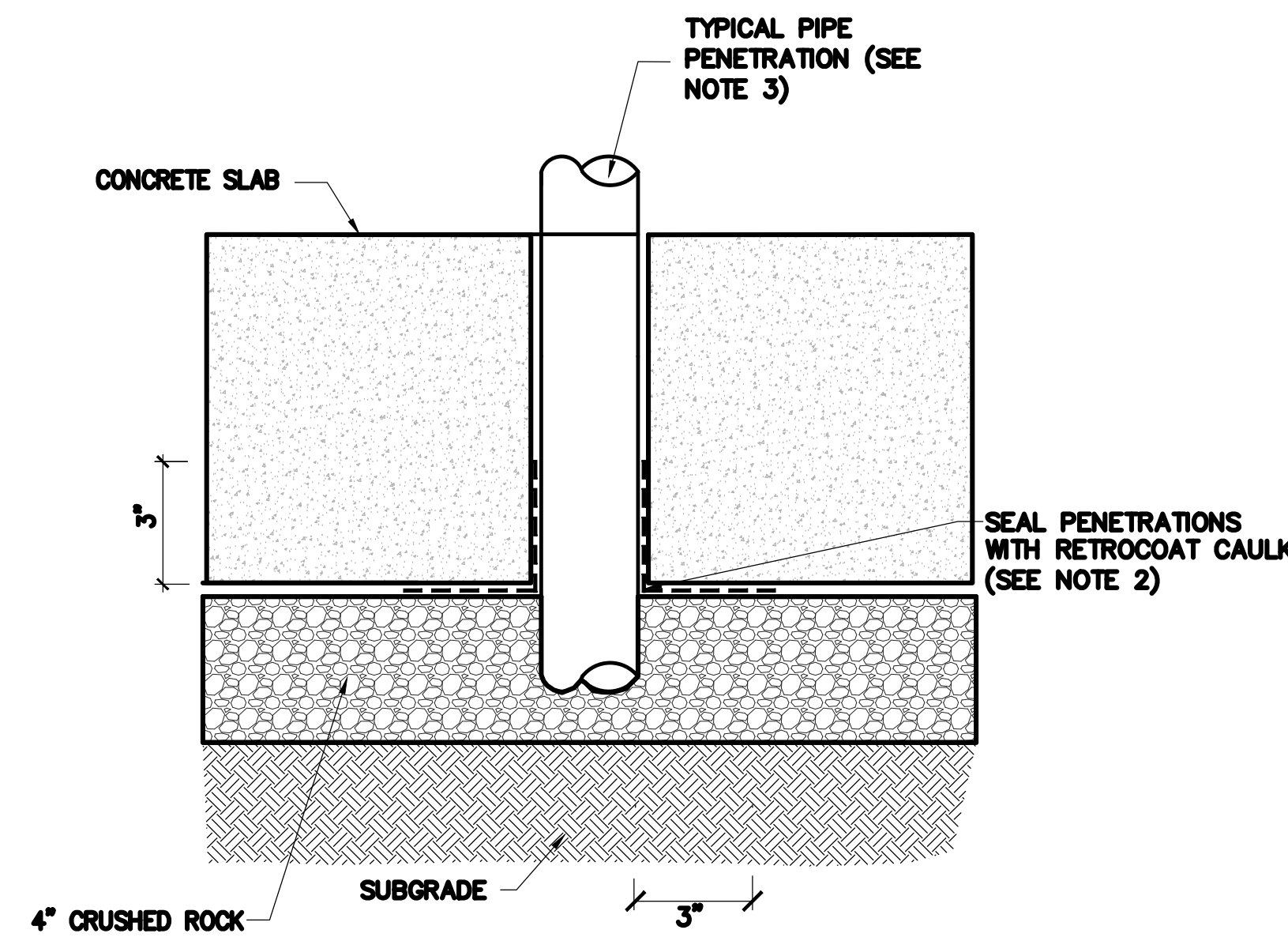

2 TYPICAL SEALING OF ALL PENETRATIONS THROUGH CONCRETE SLAB
NOT TO SCALE

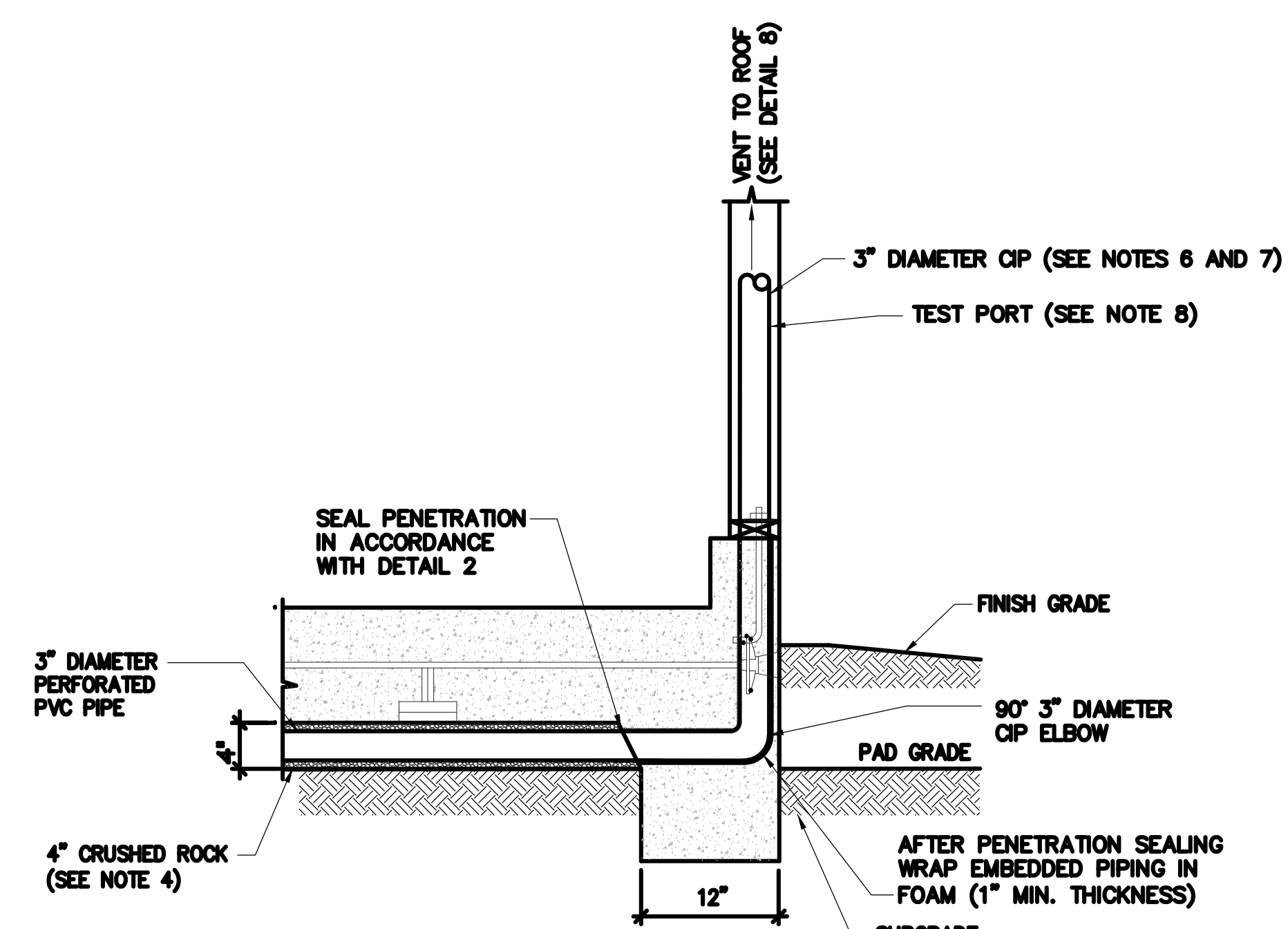

3 HORIZONTAL-TO-VERTICAL RISER TRANSITION AT EXTERIOR WALL
NOT TO SCALE

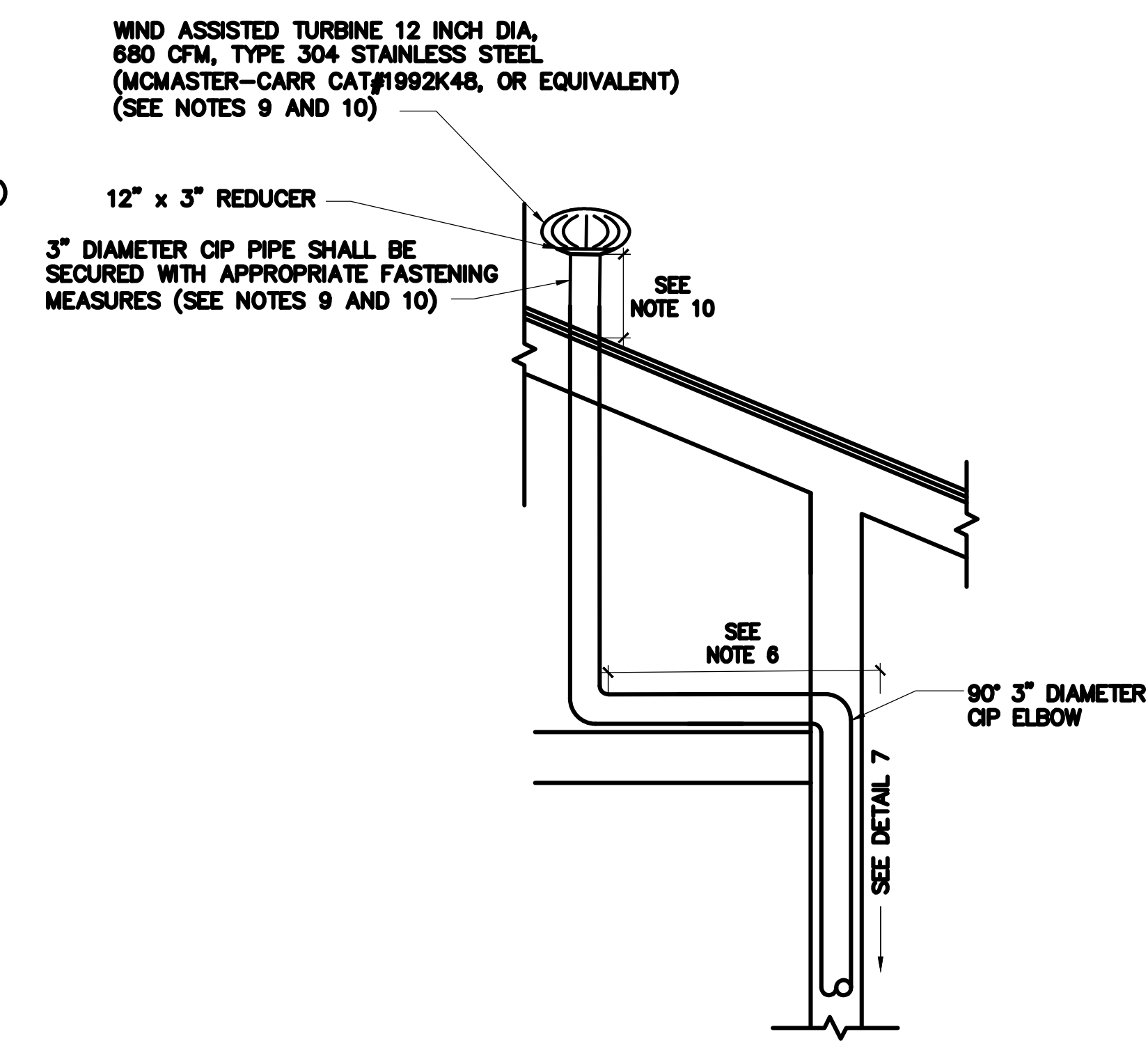

4 RISER TRANSITION INTO ATTIC AT EXTERIOR WALL AND VENT TO ROOF
NOT TO SCALE

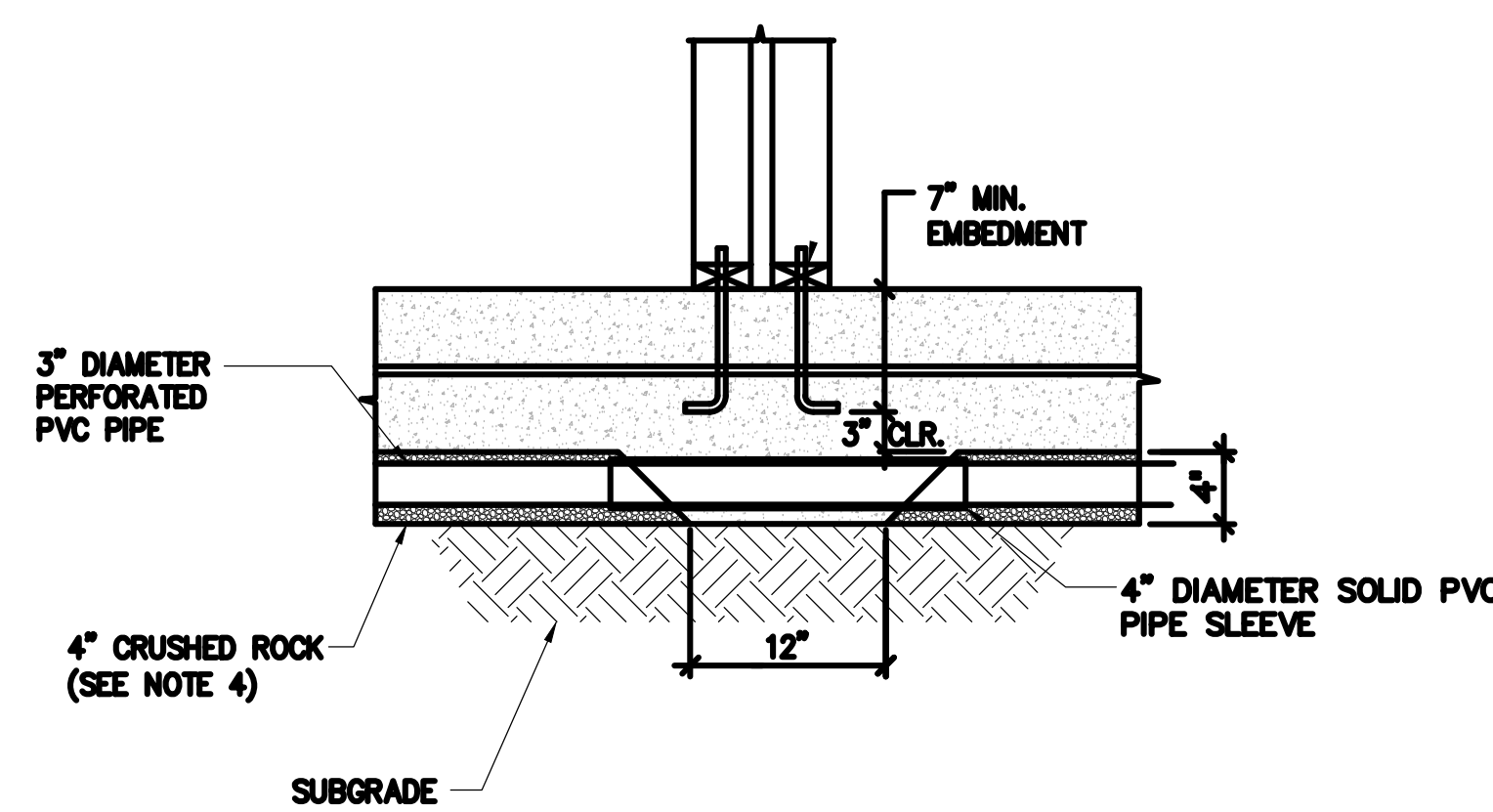

5 TYPICAL TIE-IN AT BRG/SHEAR WALL
NOT TO SCALE

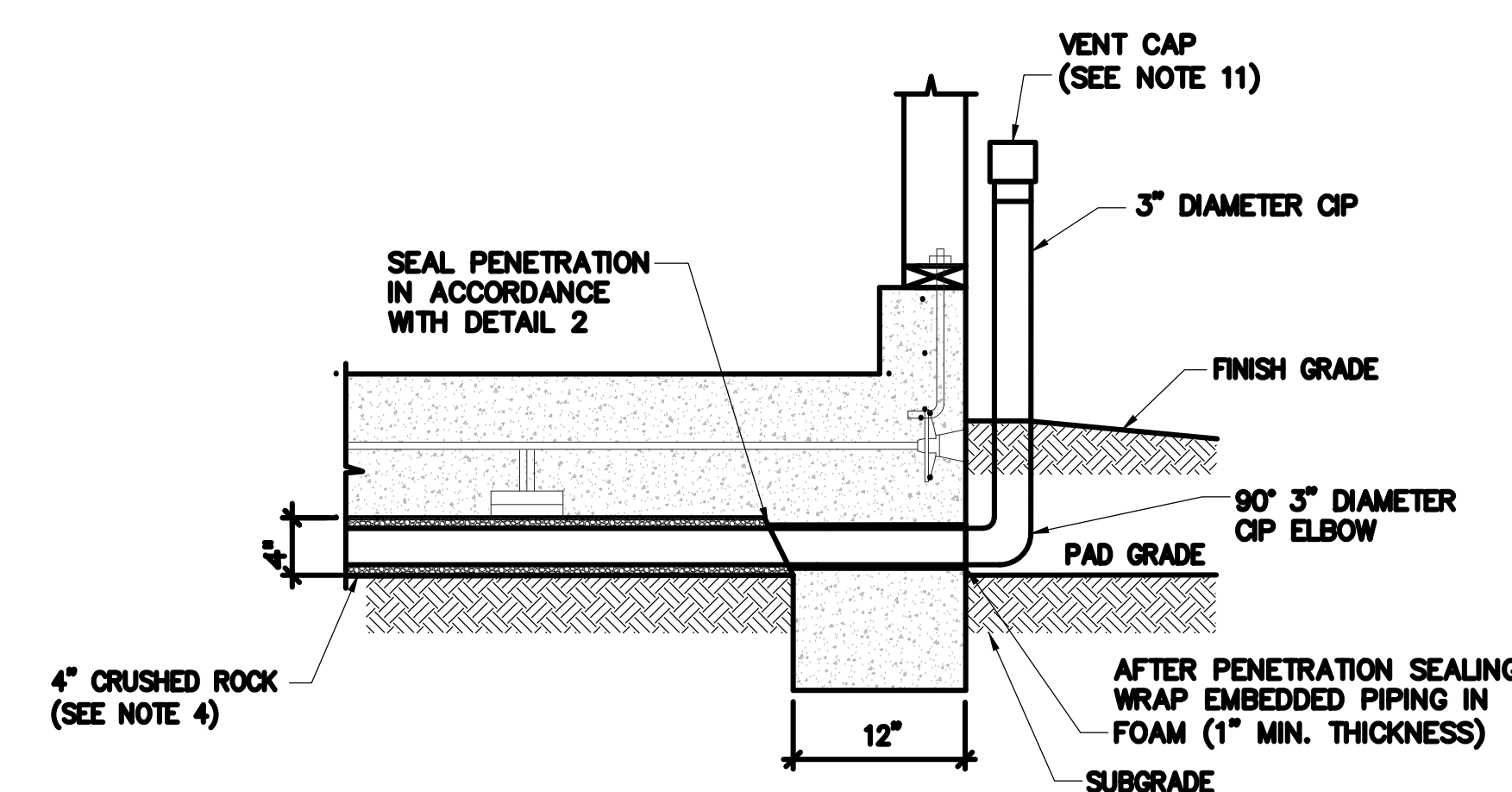

6 TYPICAL PERIMETER INLET VENT
NOT TO SCALE

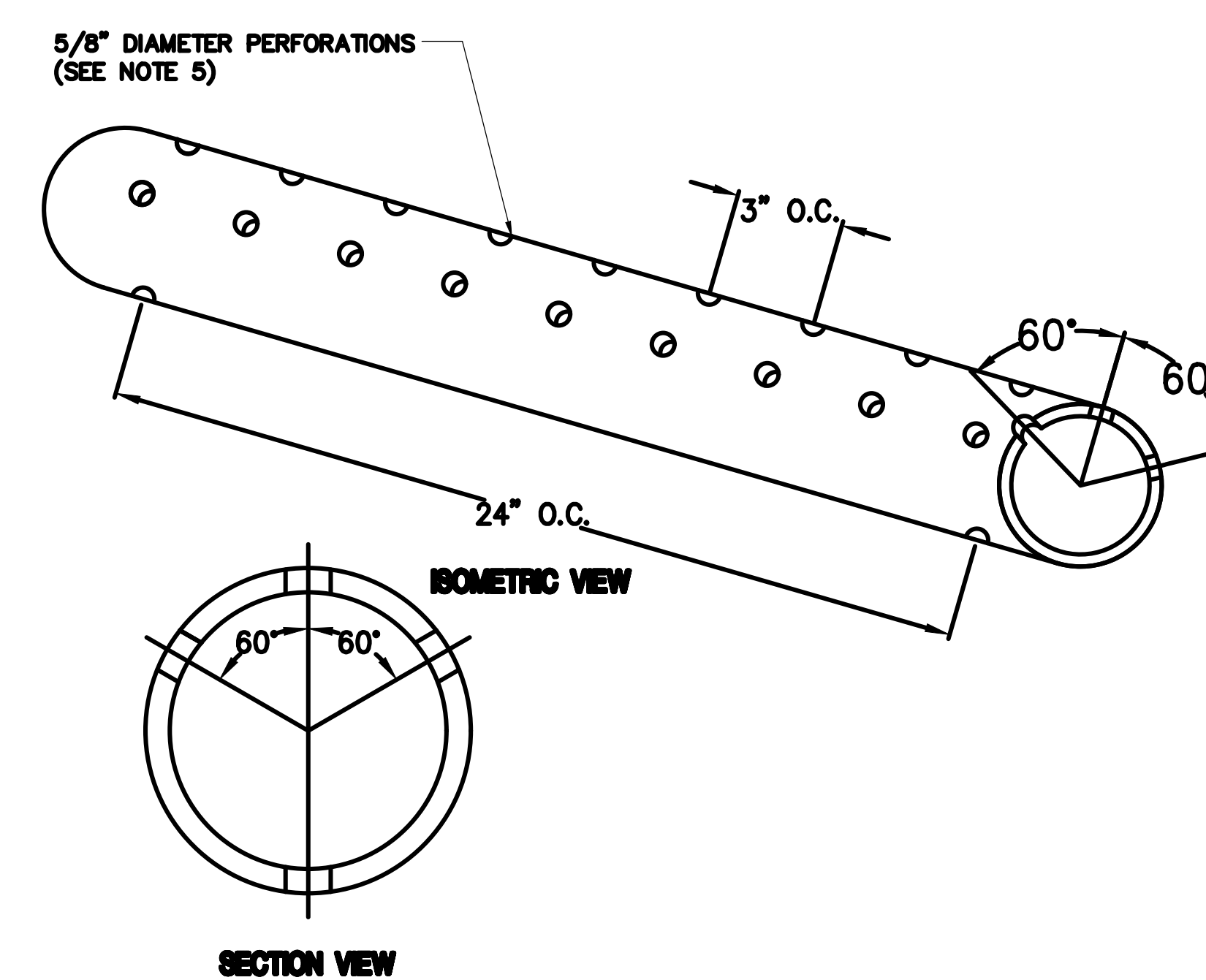

7 DETAIL OF PERFORATED PIPE PATTERN
NOT TO SCALE

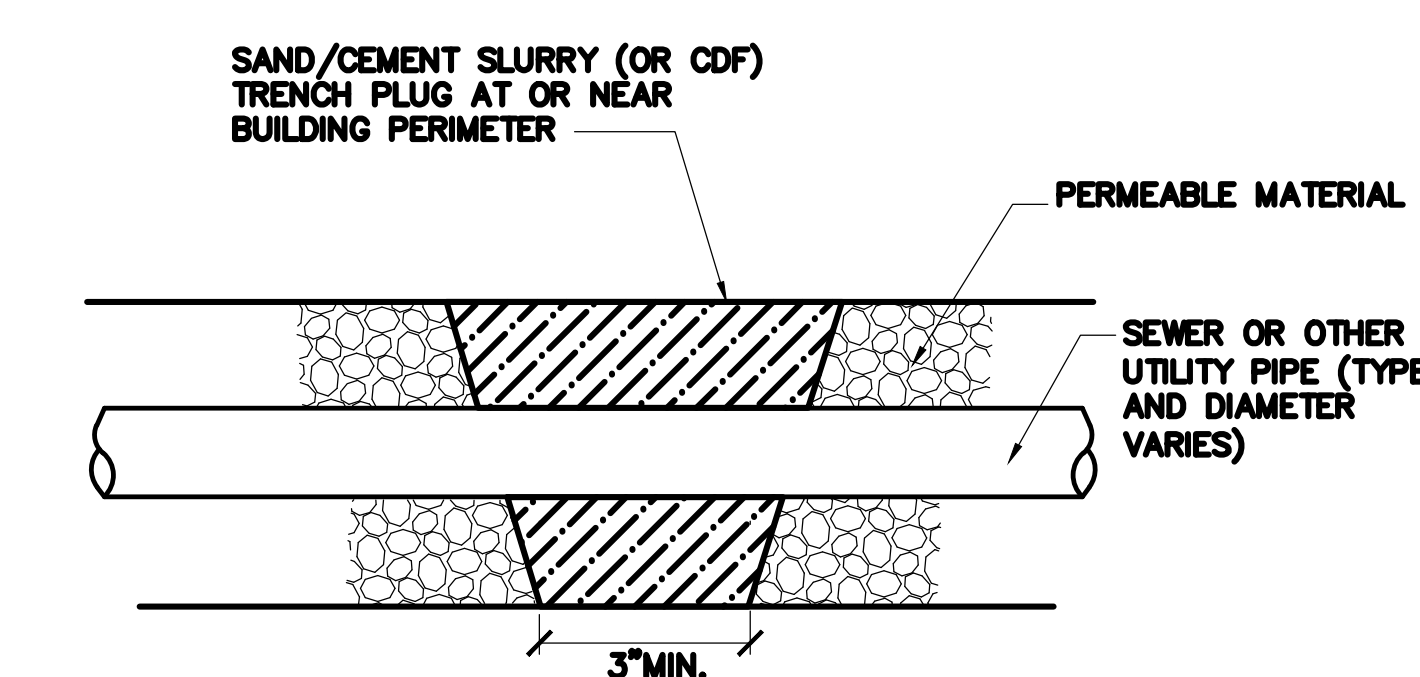

8 TYPICAL SOIL GAS CUT-OFF BARRIER IN UTILITY TRENCH
NOT TO SCALE

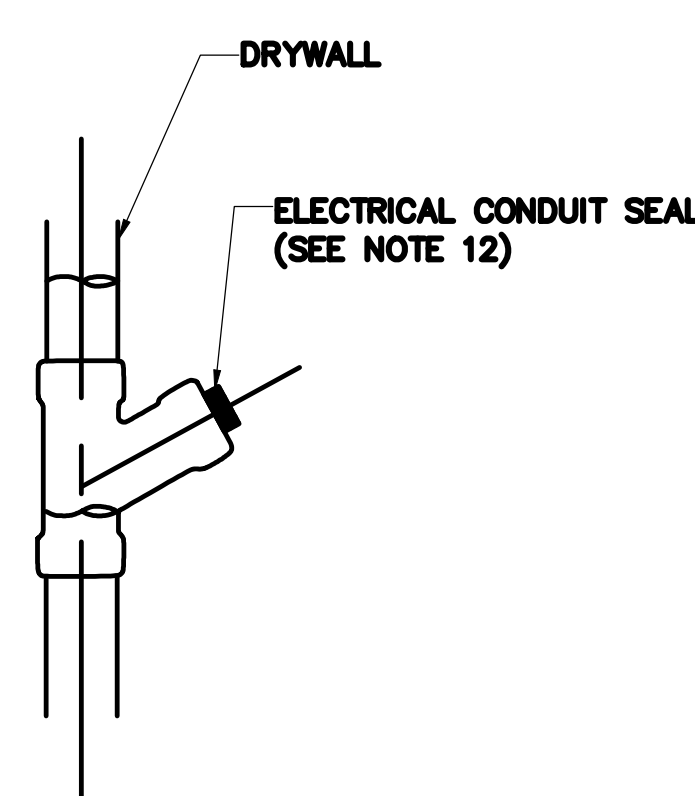

9 TYPICAL INTERIOR AND EXTERIOR CONDUIT SEAL
NOT TO SCALE

NOTES:

- ALL LOCATIONS AND DIMENSIONS OF BUILDING SLABS, FOOTINGS, SHEAR WALLS, AND GRADE BEAMS TO BE CONFIRMED WITH STRUCTURAL DETAILS.
- PENETRATIONS SHALL BE SEALED WITH RETROCOAT CAULK ACCORDING TO LAND SCIENCE TECHNOLOGIES MANUFACTURER'S SPECIFICATIONS AND QA/QC REQUIREMENTS BY A MANUFACTURER APPROVED APPLICATOR.
- SLAB PENETRATIONS SHALL NOT BE IN CONTACT WITH AN ADJACENT PENETRATION THAT WOULD PREVENT PROPER SEALING OF THE PENETRATION CIRCUMFERENCE. SLAB PENETRATIONS SHALL BE PREPARED AND STUBBED PRIOR TO APPLYING RETROCOAT CAULK.
- CRUSHED ROCK LAYER SHALL BE 1/4" X 3/4" (100% PASSING 1-INCH; 90% PASSING 1/2-INCH; 10% MAXIMUM PASSING #4). SURFACE OF CRUSHED ROCK LAYER SHALL BE SMOOTH ROLLED PRIOR TO APPLICATION OF THE CARRIER FABRIC. CRUSHED ROCK LAYER SHALL BE 4" MINIMUM.
- HORIZONTAL COLLECTION PIPE SHALL BE 3" DIAMETER SCH. 40 PVC. INDICATED SECTIONS OF HORIZONTAL COLLECTION PIPE SHALL BE PERFORATED WITH 5/8 INCH DIAMETER HOLES, THREE HOLES ACROSS THE UPPER ONE-THIRD OF THE PIPE, EVERY THREE INCHES ALONG THE PERFORATED SECTION. AN ADDITIONAL 5/8 INCH DIAMETER HOLE SHALL BE DRILLED ON THE UNDERSIDE OF THE PIPE AT LEAST EVERY TWO LINEAR FEET ALONG THE PERFORATED SECTION TO ALLOW WATER, IF ANY, TO DRAIN FROM THE PIPE.
- VERTICAL RISER PIPES SHALL BE SUPPORTED AT THE PIPE CHASE WALLS, AS NEEDED. PIPE MUST BE 3" DIAMETER CAST IRON PIPE (CIP). MINOR (< 5 FEET) JOGS IN THE VERTICAL RISER AT ATTIC LEVEL ARE ACCEPTABLE.
- VERTICAL RISER PIPES SHALL BE LABELED AS 'CONTAINS VAPORS; DO NOT BREAK OR CUT.'
- TEST PORTS SHALL BE INSTALLED ON VERTICAL RISER PIPES, 36 INCHES ABOVE GROUND LEVEL, FOR AIR SAMPLING. TEST PORT SHALL BE BRASS TUBE FITTING, BORED-THROUGH MALE CONNECTOR, WITH 1/4-INCH TUBE OD 1/4-INCH MALE NPT (SWAGELOCK® B-400-1-4BT OR EQUIVALENT). TEST PORT CAP SHALL BE BRASS CAP FOR 1/4-INCH OD TUBING (SWAGELOCK® B-400-C OR EQUIVALENT). A LOCKABLE ACCESS HATCH AT THE EXTERIOR WALL FACE SHALL BE INSTALLED TO ALLOW ACCESS TO SAMPLING PORTS.
- THE TOP OF THE VERTICAL RISER PIPES (W) SHALL EXTEND TO AN ELEVATION OF 1 FOOT ABOVE THE ROOF AND ALLOW THE WIND TURBINES TO OPERATE FREELY; THEY SHALL BE LOCATED A MINIMUM OF 15 FEET AWAY FROM FRESH AIR INTAKES FOR BUILDING'S HVAC SYSTEM OR OTHER OPENINGS (O'HAGN VENTS, WINDOWS, DOORS, ETC.), AND SHALL BE SUPPORTED BY STRUTS OR STRAPS ATTACHED TO AN ADJACENT STRUCTURAL ELEMENT.

- THE WIND-ASSISTED TURBINE ON TOP OF THE 3 INCH PVC RISER SHALL BE 12 INCH DIAMETER, 680 CFM, TYPE 304 STAINLESS STEEL (MCMASTER-CARR CAT#1992K48, OR EQUIVALENT) AND SHALL BE SECURED TO THE TOP OF THE RISER. TURBINE SHALL BE ADAPTED TO FIT A 3 INCH PIPE. TURBINE SHALL BE INSTALLED TO RESIST WIND, SEISMIC, AND OTHER LOADS, AS NEEDED.
- PERIMETER VENTS SHALL BE EQUIPPED WITH A RAIN CAP THAT WILL ALLOW FRESH AIR FLOW INTO THE INLET BUT NOT RAIN OR FOREIGN OBJECTS TO FALL INTO THE VENT.
- MECHANICAL, ELECTRICAL, AND PLUMBING CONDUIT PENETRATIONS IN THE WALLS ON THE LOWEST LEVEL OF THE STRUCTURE SHALL BE SEALED AIR-TIGHT USING APPROPRIATE SEALING PRODUCT (FIRE CAULKING OR SIMILAR SEALANT).

Date	Description	No.
11/21/16	SUBMITTAL TO ALAMEDA COUNTY	1
REVISIONS		
		
SIGNATURE		DATE SIGNED
		
LANGAN <small>305 Montgomery Street, Suite 1300, San Francisco, CA 94111 T: 415.955.5200 F: 415.955.5201 www.langan.com</small>		
Project		
THE BUNGALOWS		
SAN LORENZO BOCKMAN DRIVE CALIFORNIA		
Drawing Title		
VAPOR MITIGATION SYSTEM DETAILS INITIAL CONSTRUCTION		
Project No.	770625803	Drawing No.
Date	11/02/16	
Scale	Not to Scale	VMS2.01A
Drawn By	HB	Checked By
		SR
Submission Date	11/21/16	Sheet 7 of 8

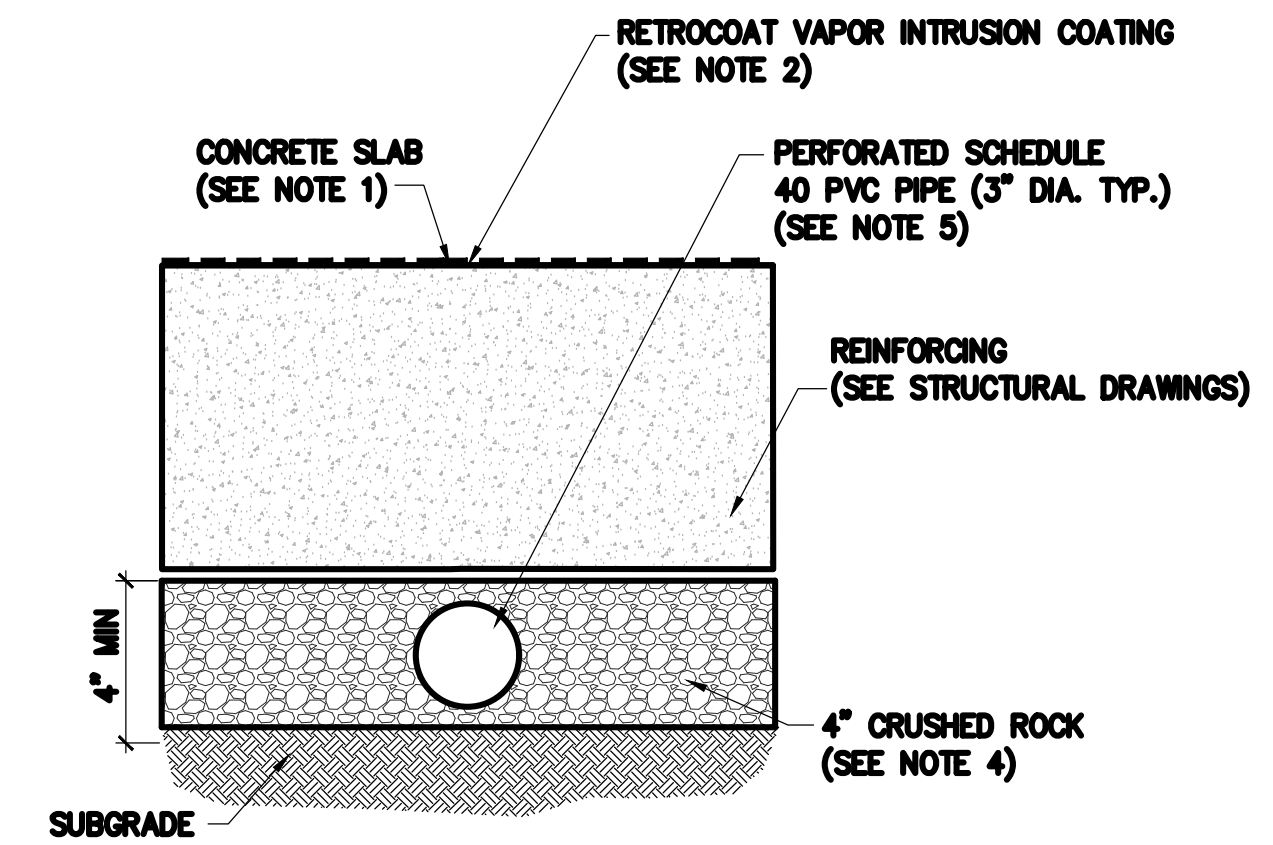

1 TYPICAL VAPOR MITIGATION SYSTEM CROSS-SECTION
NOT TO SCALE

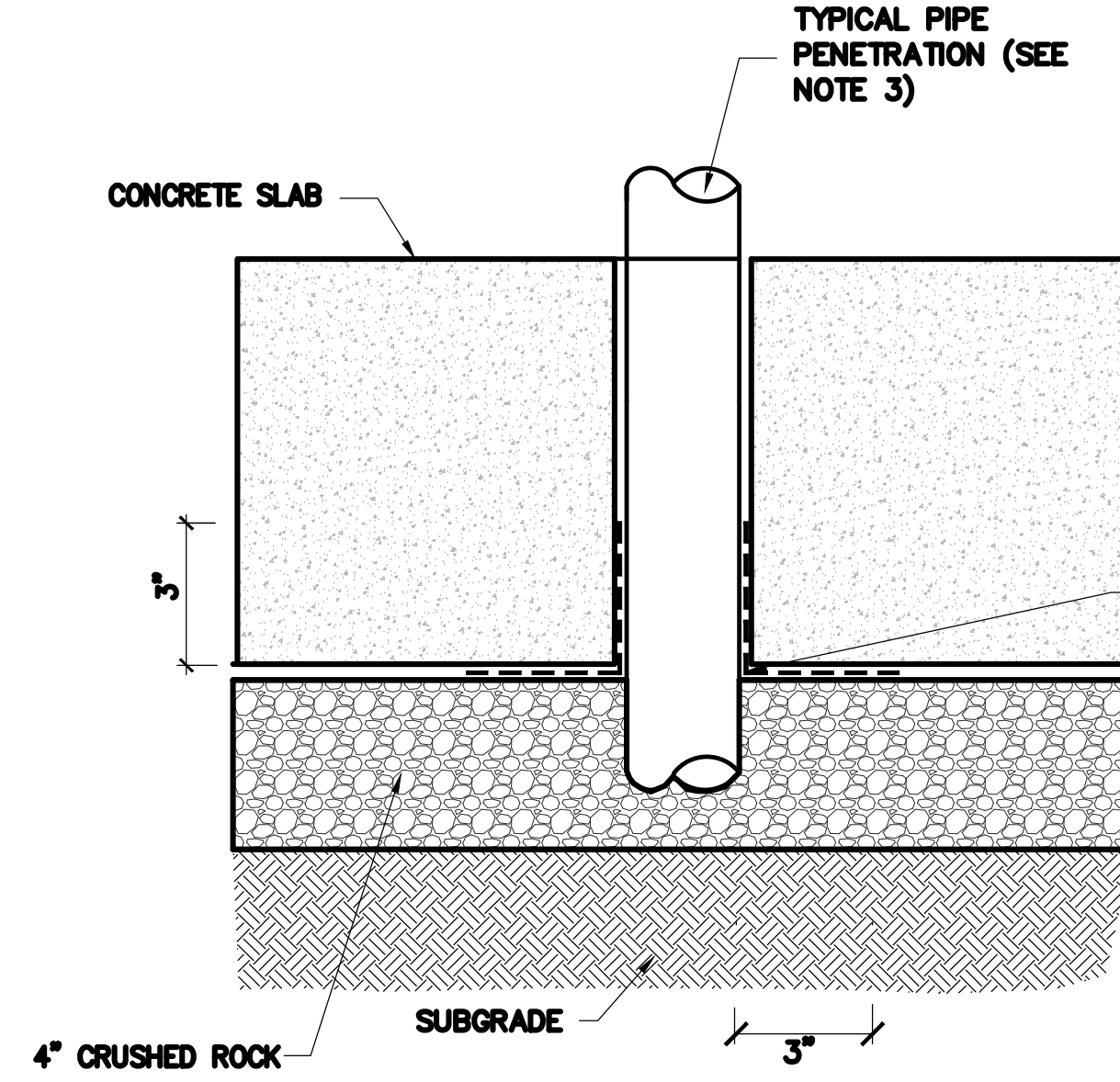

2 TYPICAL SEALING OF ALL PENETRATIONS THROUGH CONCRETE SLAB
NOT TO SCALE

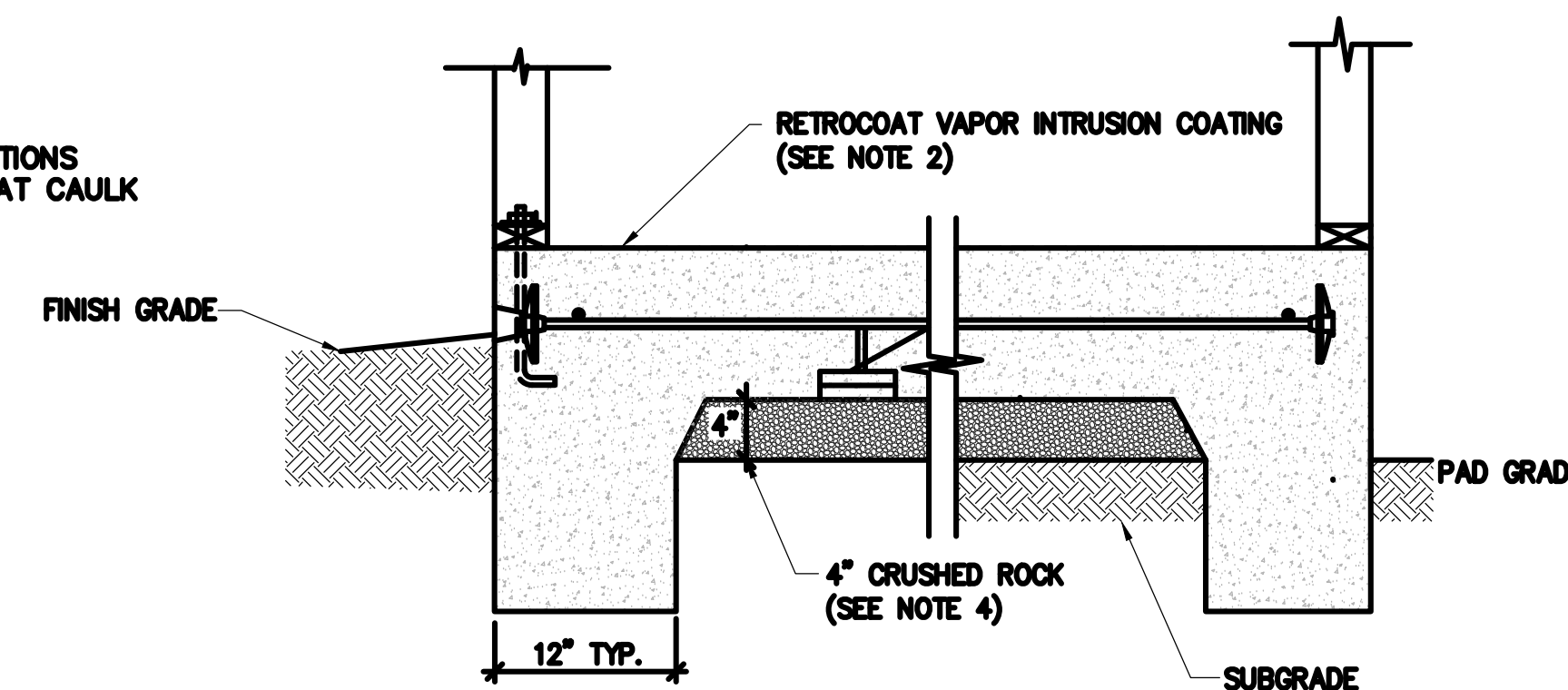

3 TYPICAL RETROCOAT COATING AT THICKENED SLAB EDGE
NOT TO SCALE

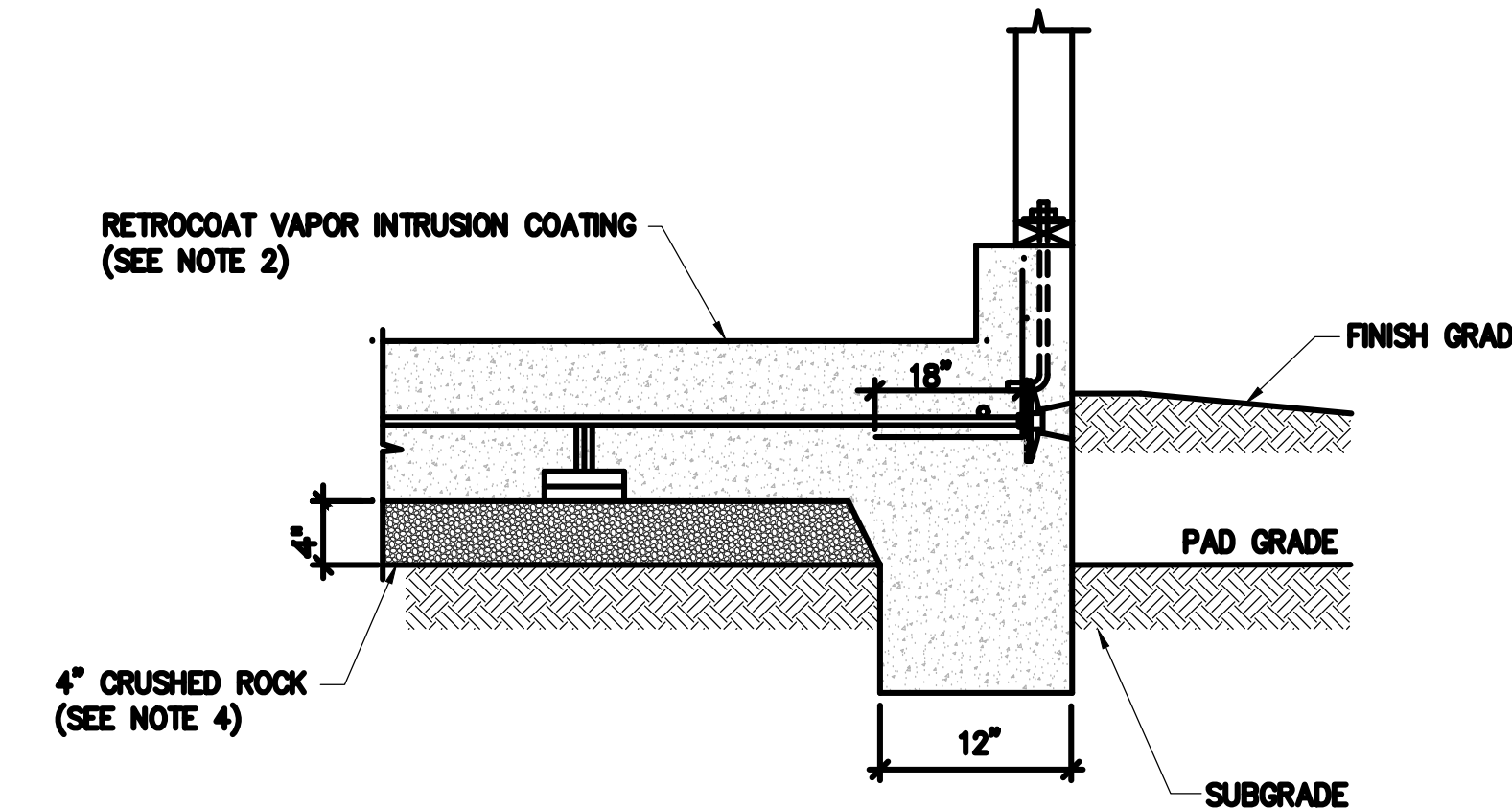

4 TYPICAL RETROCOAT COATING AT THICKENED SLAB EDGE
NOT TO SCALE

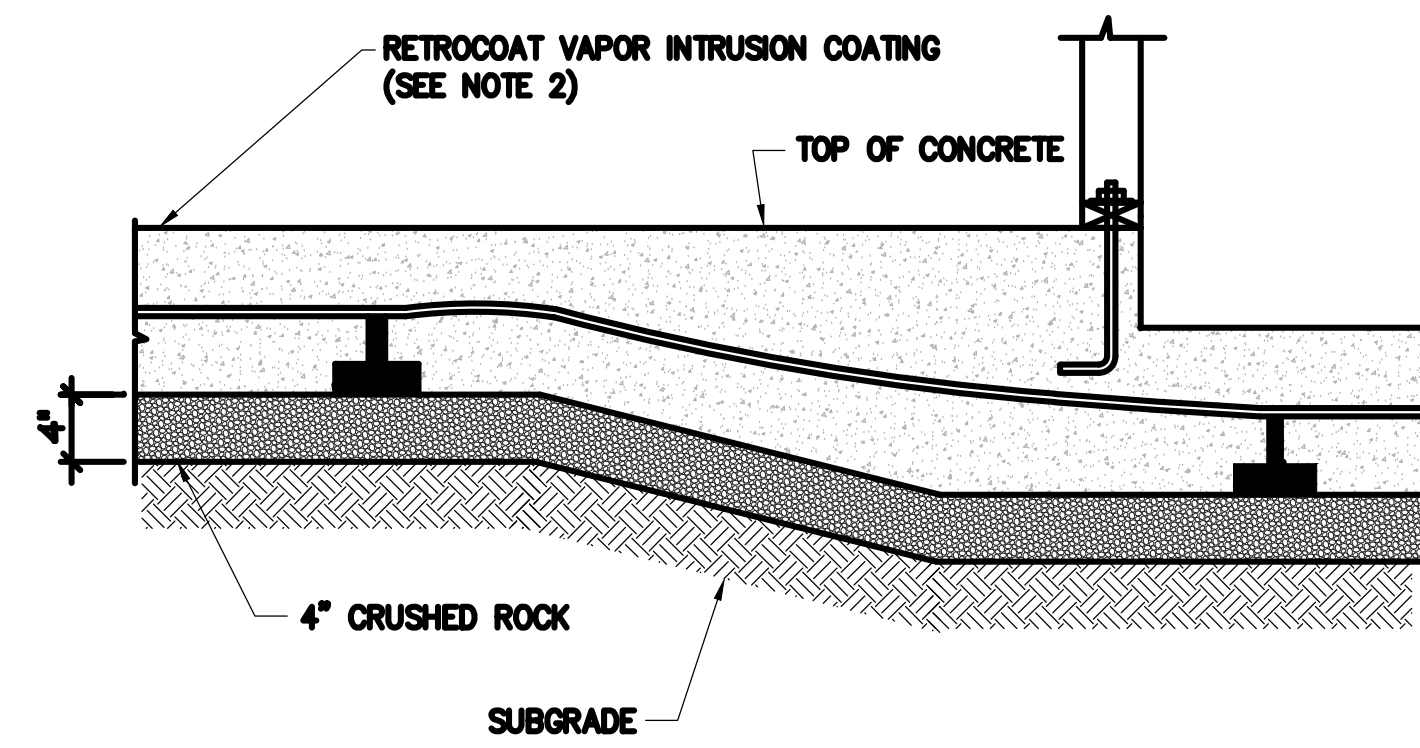

5 TYPICAL RETROCOAT COATING AT STEP IN SLAB
NOT TO SCALE

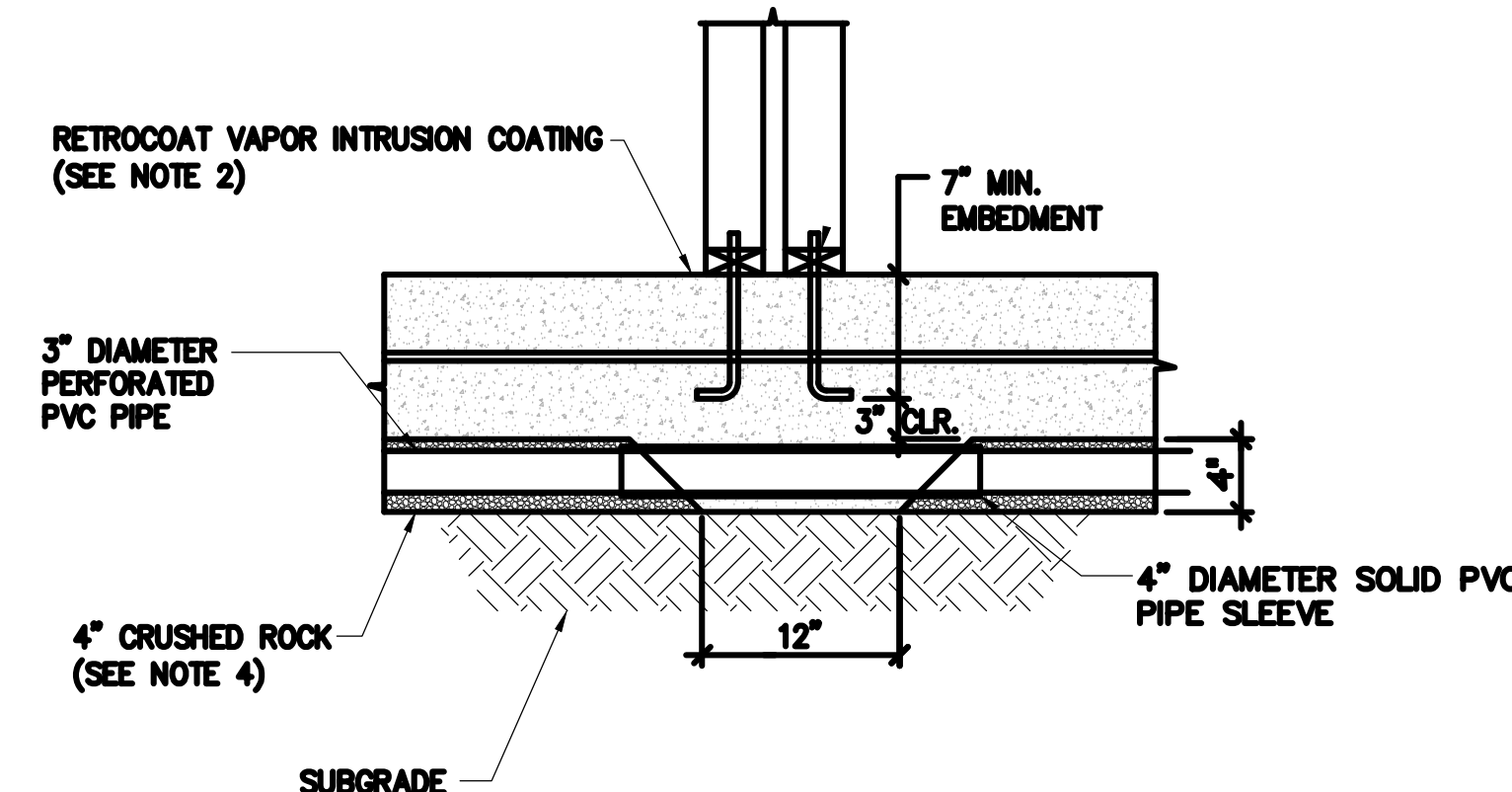

6 TYPICAL RETROCOAT COATING AT BRG/SHEAR WALL
NOT TO SCALE

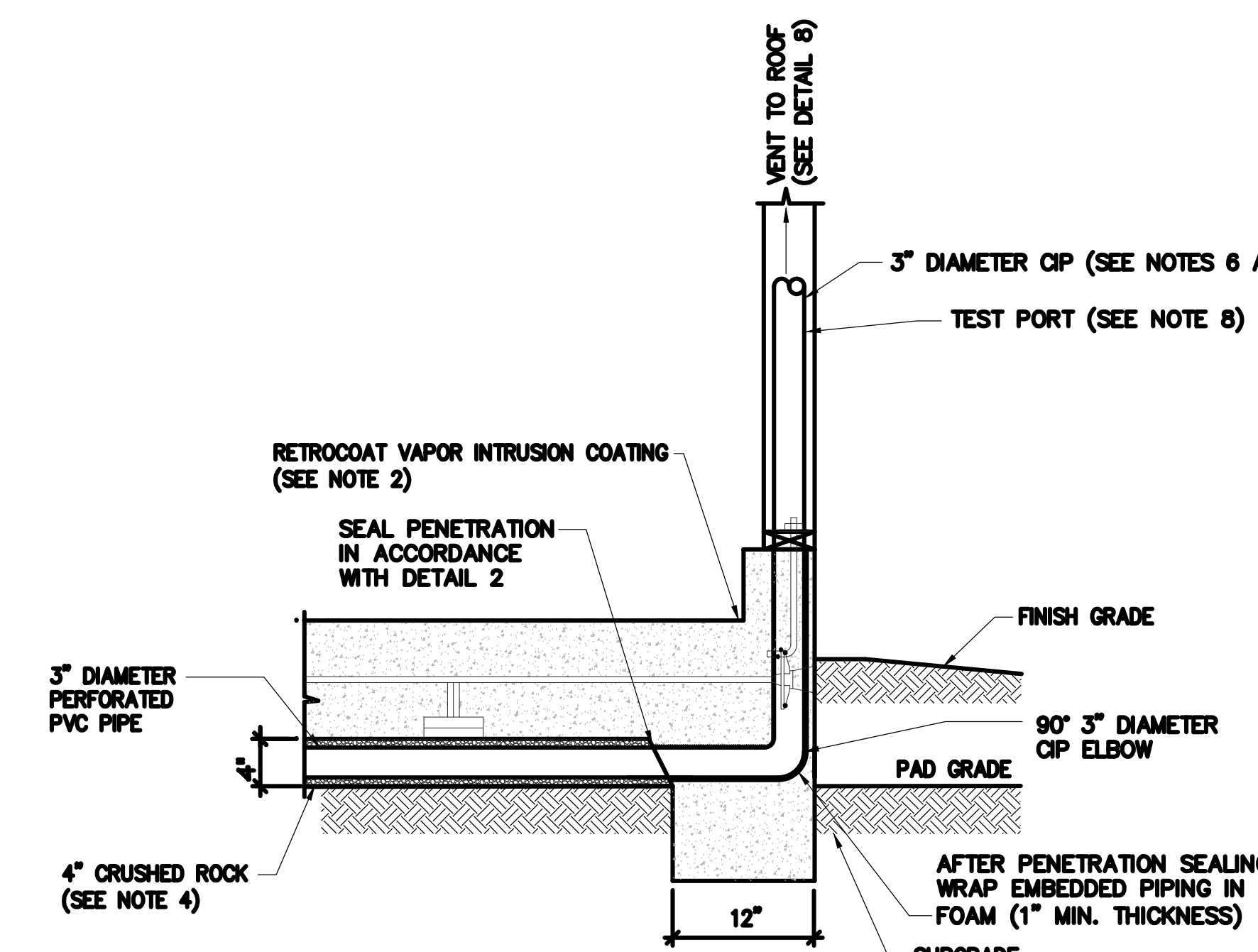

7 HORIZONTAL-TO-VERTICAL RISER TRANSITION AT EXTERIOR WALL
NOT TO SCALE

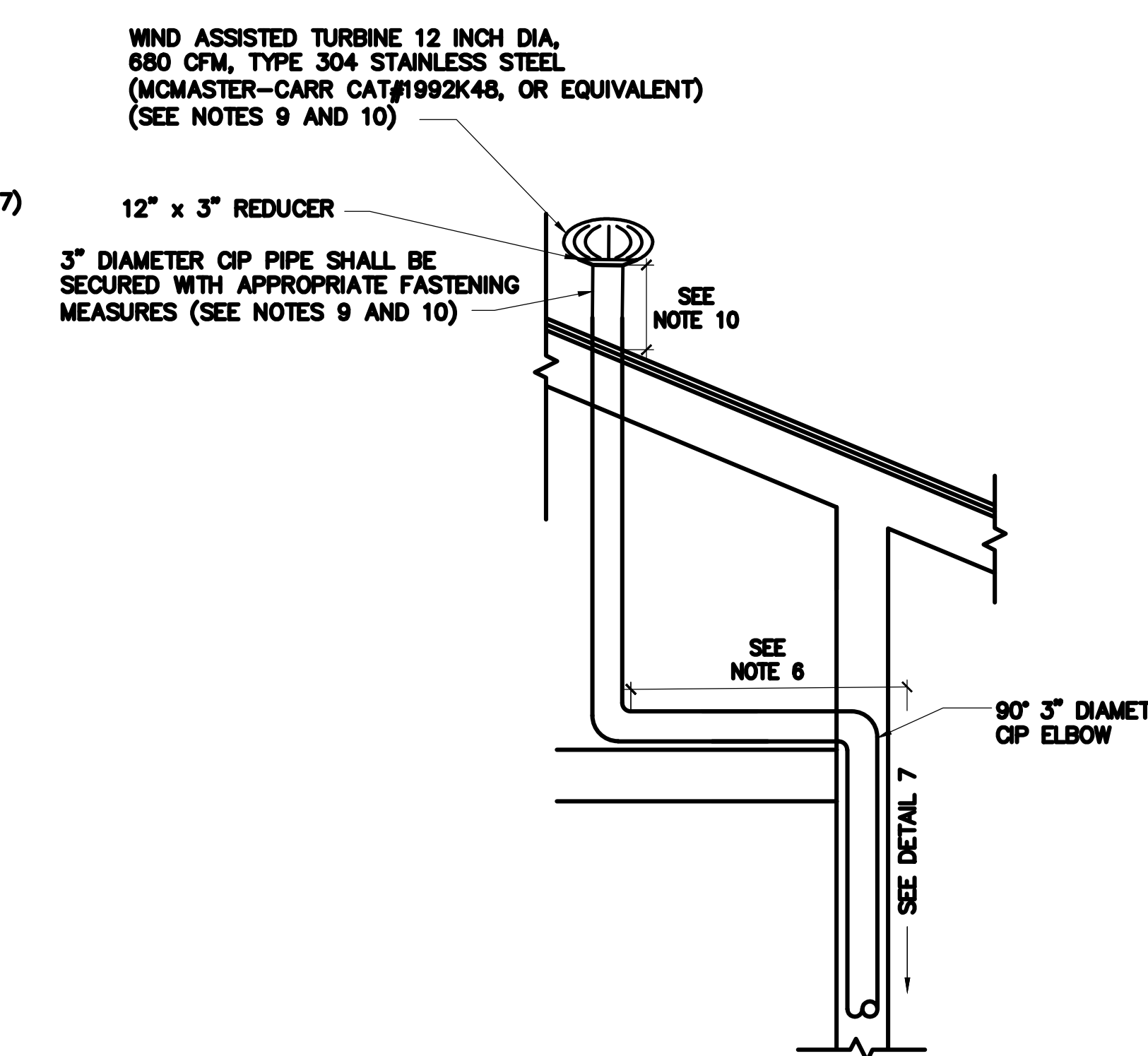

8 RISER TRANSITION INTO ATTIC AT EXTERIOR WALL AND VENT TO ROOF
NOT TO SCALE

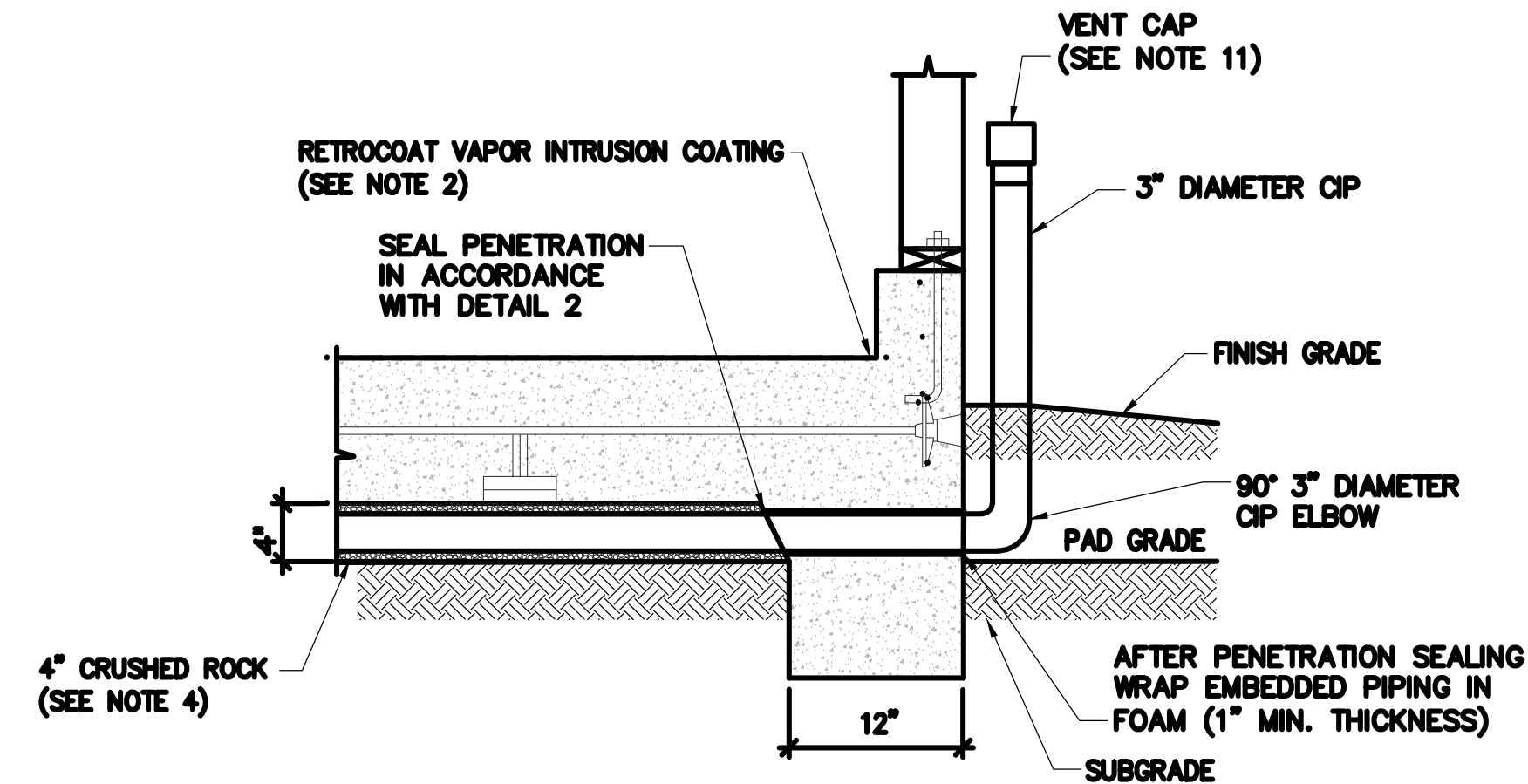

9 TYPICAL PERIMETER INLET VENT
NOT TO SCALE

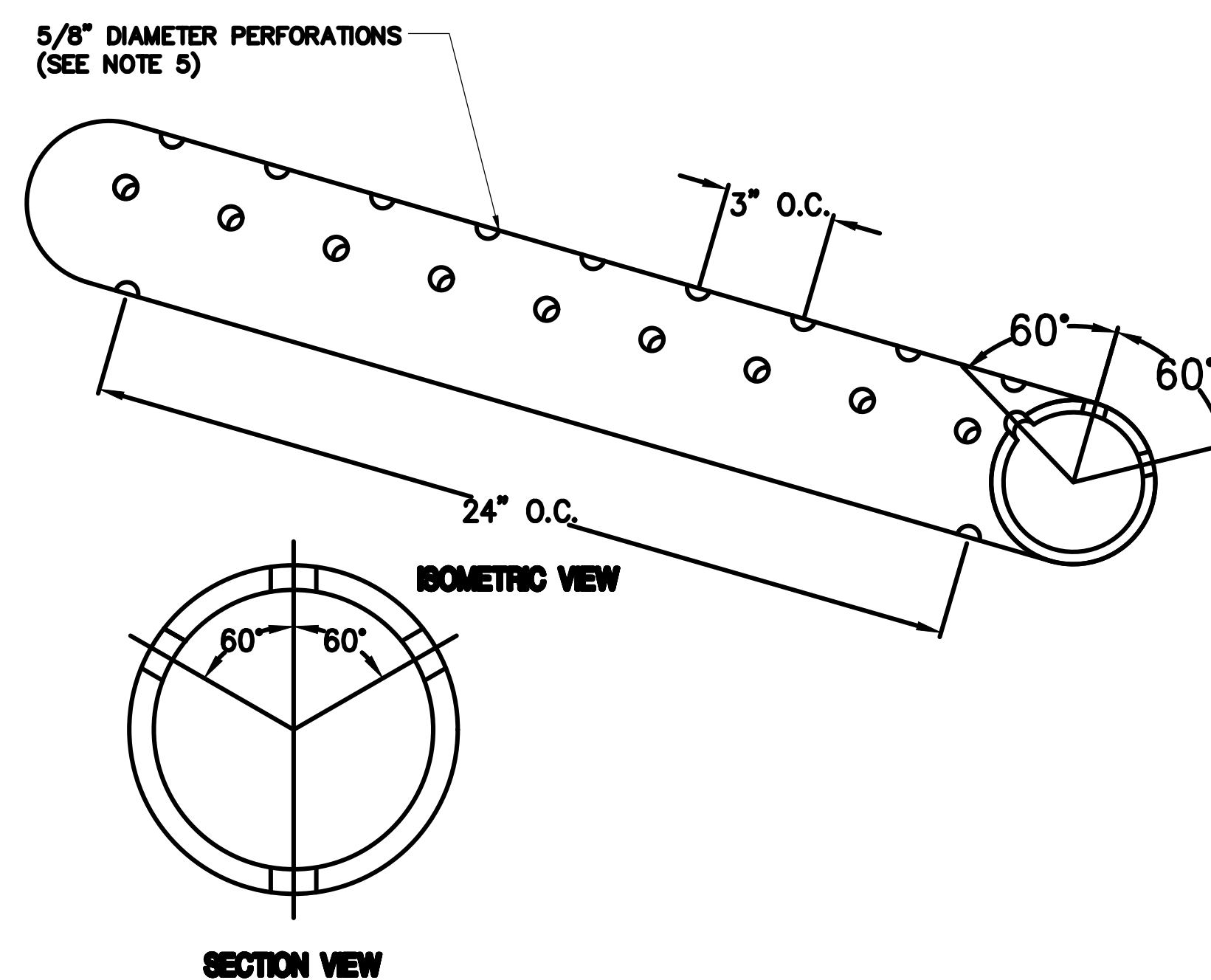

10 DETAIL OF PERFORATED PIPE PATTERN
NOT TO SCALE

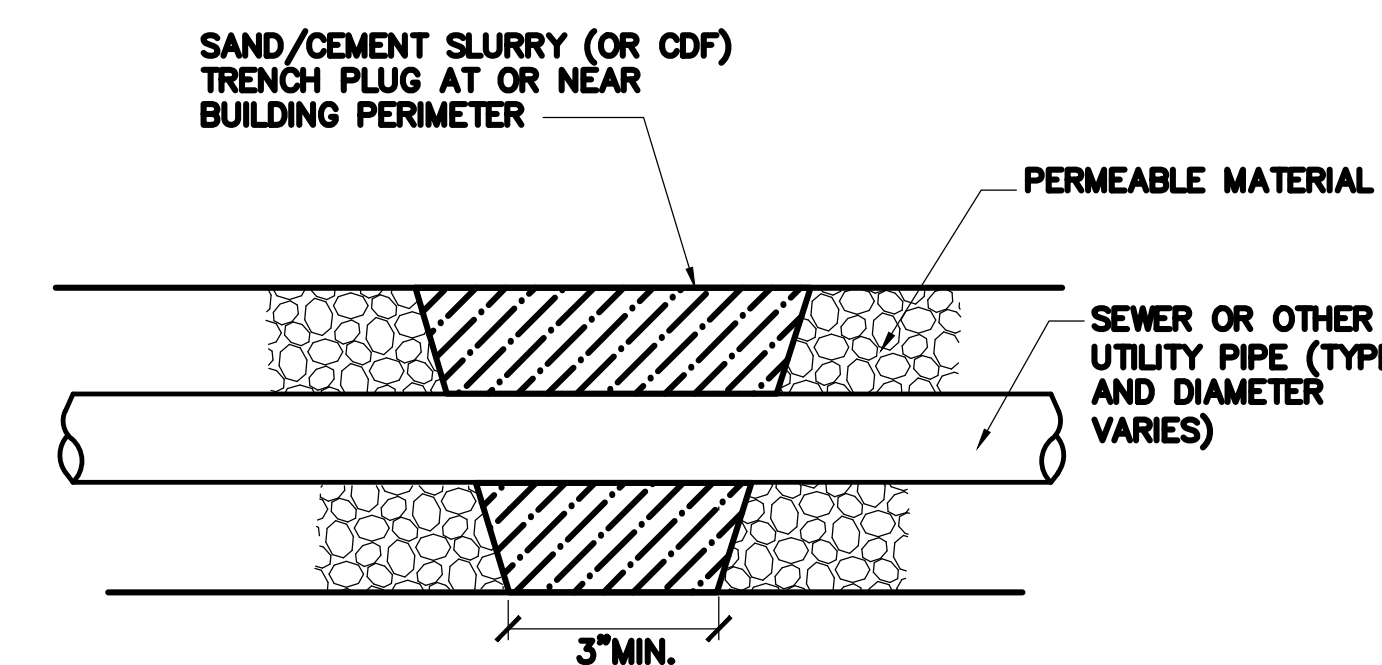

11 TYPICAL SOIL GAS CUT-OFF BARRIER IN UTILITY TRENCH
NOT TO SCALE

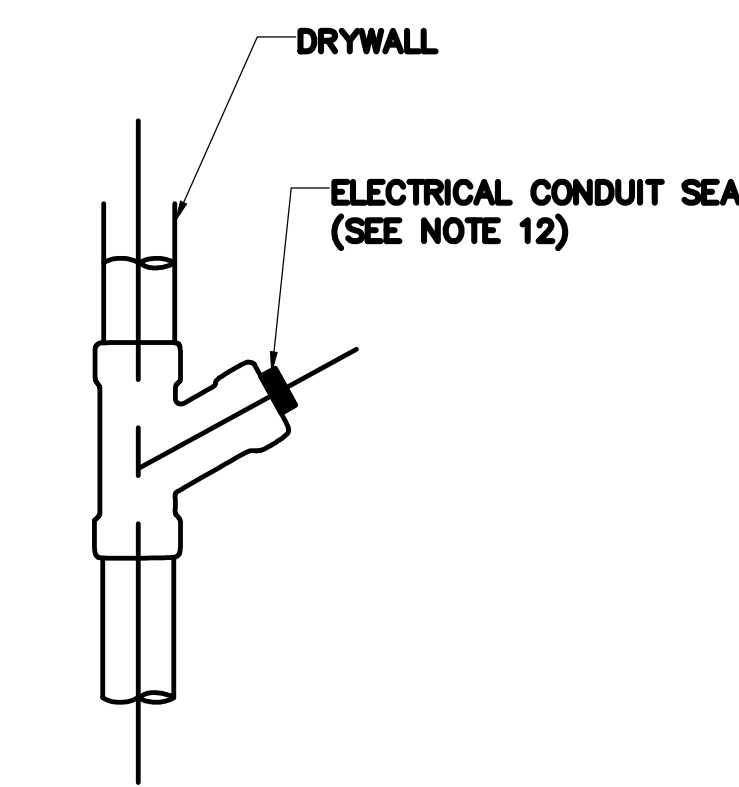

12 TYPICAL INTERIOR AND EXTERIOR CONDUIT SEAL
NOT TO SCALE

NOTES:

- ALL LOCATIONS AND DIMENSIONS OF BUILDING SLABS, FOOTINGS, SHEAR WALLS, AND GRADE BEAMS TO BE CONFIRMED WITH STRUCTURAL DETAILS.
- THE RETROCOAT VAPOR INTRUSION COATING AND RETROCOAT CAULK SHALL BE INSTALLED ACCORDING TO LAND SCIENCE TECHNOLOGIES MANUFACTURER'S SPECIFICATIONS AND QA/QC REQUIREMENTS BY A MANUFACTURER APPROVED APPLICATOR.
- SLAB PENETRATIONS SHALL NOT BE IN CONTACT WITH AN ADJACENT PENETRATION THAT WOULD PREVENT PROPER SEALING OF THE PENETRATION CIRCUMFERENCE. SLAB PENETRATIONS SHALL BE PREPARED AND STUBBED PRIOR TO APPLYING RETROCOAT CAULK.
- CRUSHED ROCK LAYER SHALL BE 1/4" X 3/4" (100% PASSING 1-INCH; 90% PASSING 1/2-INCH; 10% MAXIMUM PASSING #4). SURFACE OF CRUSHED ROCK LAYER SHALL BE SMOOTH ROLLED PRIOR TO APPLICATION OF THE CARRIER FABRIC. CRUSHED ROCK LAYER SHALL BE 4" MINIMUM.
- HORIZONTAL COLLECTION PIPE SHALL BE 3" DIAMETER SCH. 40 PVC. INDICATED SECTIONS OF HORIZONTAL COLLECTION PIPE SHALL BE PERFORATED WITH 5/8 INCH DIAMETER HOLES, THREE HOLES ACROSS THE UPPER ONE-THIRD OF THE PIPE, EVERY THREE INCHES ALONG THE PERFORATED SECTION. AN ADDITIONAL 5/8 INCH DIAMETER HOLE SHALL BE DRILLED ON THE UNDERSIDE OF THE PIPE AT LEAST EVERY TWO LINEAR FEET ALONG THE PERFORATED SECTION TO ALLOW WATER, IF ANY, TO DRAIN FROM THE PIPE.
- VERTICAL RISER PIPES SHALL BE SUPPORTED AT THE PIPE CHASE WALLS, AS NEEDED. PIPE MUST BE 3" DIAMETER CAST IRON PIPE (CIP). MINOR (< 5 FEET) JOGS IN THE VERTICAL RISER AT ATTIC LEVEL ARE ACCEPTABLE.
- VERTICAL RISER PIPES SHALL BE LABELED AS 'CONTAINS VAPORS; DO NOT BREAK OR CUT.'
- TEST PORTS SHALL BE INSTALLED ON VERTICAL RISER PIPES, 36 INCHES ABOVE GROUND LEVEL, FOR AIR SAMPLING. TEST PORT SHALL BE BRASS TUBE FITTING, BORED-TROUGH MALE CONNECTOR, WITH 1/4-INCH TUBE OD 1/4-INCH MALE NPT (SWAGelok® B-400-1-4BT OR EQUIVALENT), TEST PORT CAP SHALL BE BRASS CAP FOR 1/4-INCH OD TUBING (SWAGelok® B-400-C OR EQUIVALENT). A LOCKABLE ACCESS HATCH AT THE EXTERIOR WALL FACE SHALL BE INSTALLED TO ALLOW ACCESS TO SAMPLING PORTS.

- THE TOP OF THE VERTICAL RISER PIPES (V) SHALL EXTEND TO AN ELEVATION OF 1 FOOT ABOVE THE ROOF AND ALLOW THE WIND TURBINES TO OPERATE FREELY; THEY SHALL BE LOCATED A MINIMUM OF 15 FEET AWAY FROM FRESH AIR INTAKES FOR BUILDING'S HVAC SYSTEM OR OTHER OPENINGS (HORN VENTS, WINDOWS, DOORS, ETC.) AND SHALL BE SUPPORTED BY STRUTS OR STRAPS ATTACHED TO AN ADJACENT STRUCTURAL ELEMENT.
- THE WIND-ASSISTED TURBINE ON TOP OF THE 3 INCH PVC RISER SHALL BE 12 INCH DIAMETER, 680 CFM, TYPE 304 STAINLESS STEEL (MCMASTER-CARR CAT#1992K48, OR EQUIVALENT) AND SHALL BE SECURED TO THE TOP OF THE RISER. TURBINE SHALL BE ADAPTED TO FIT A 3 INCH PIPE. TURBINE SHALL BE INSTALLED TO RESIST WIND, SEISMIC, AND OTHER LOADS, AS NEEDED.
- PERIMETER VENTS SHALL BE EQUIPPED WITH A RAIN CAP THAT WILL ALLOW FRESH AIR FLOW INTO THE INLET BUT NOT RAIN OR FOREIGN OBJECTS TO FALL INTO THE VENT.
- MECHANICAL, ELECTRICAL, AND PLUMBING CONDUIT PENETRATIONS IN THE WALLS ON THE LOWEST LEVEL OF THE STRUCTURE SHALL BE SEALED AIR-TIGHT USING APPROPRIATE SEALING PRODUCT (FIRE CAULKING OR SIMILAR SEALANT).

Date	Description	No.
11/21/16	SUBMITAL TO ALAMEDA COUNTY	1
REVISIONS		
		
SIGNATURE		DATE SIGNED
PROFESSIONAL ENGINEER		STATE LIC. NO. 69777
LANGAN <small>305 Montgomery Street, Suite 3000, San Francisco, CA 94111 T: 415.955.5200 F: 415.955.5201 www.langan.com</small>		
Project		
THE BUNGALOWS		
SAN LORENZO BOCKMAN DRIVE CALIFORNIA		
Drawing Title		
VAPOR MITIGATION SYSTEM DETAILS WITH POST-CONSTRUCTION RETROCOAT		
Project No.	Drawing No.	
770625803	VMS2.01B	
Date	11/07/16	
Scale	Not to Scale	
Drawn By	Checked By	
HB	SK	
Submission Date	11/21/16	
	Sheet 8 of 8	

Appendix C

Wind-Turbine Fan and Active Blower Specifications



RP Series

Radon Mitigation Fan

All RadonAway® fans are specifically designed for radon mitigation. RP Series Fans provide superb performance, run ultra-quiet and are attractive. They are ideal for most sub-slab radon mitigation systems.

Features

- Energy efficient
- Ultra-quiet operation
- Meets all electrical code requirements
- Water-hardened motorized impeller
- Seams sealed to inhibit radon leakage (RP140 & RP145 double snap sealed)
- ETL Listed - for indoor or outdoor use
- Thermally protected motor
- Rated for commercial and residential use



MODEL	P/N	FAN DUCT DIAMETER	WATTS	MAX. PRESSURE"WC	TYPICAL CFM vs. STATIC PRESSURE WC				
					0"	.5"	1.0"	1.5"	2.0"
RP140*	23029-1	4"	15-21	0.8	135	70	-	-	-
RP145	23030-1	4"	41-72	2.1	166	126	82	41	3
RP260	23032-1	6"	50-75	1.6	272	176	89	13	-
RP265	23033-1	6"	91-129	2.3	334	247	176	116	52
RP380	28208	8"	95-152	2.3	497	353	220	130	38

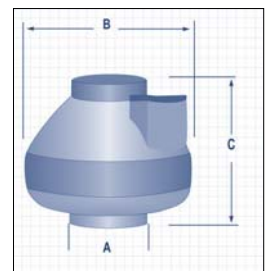

Made in USA with US and imported parts



ETL Listed



All RadonAway inline radon fans are covered by our 5-year, hassle-free warranty



*Energy Star® Rated

Model	A	B	C
RP140	4.5"	9.7"	8.5"
RP145	4.5"	9.7"	8.5"
RP260	6"	11.75"	8.6"
RP265	6"	11.75"	8.6"
RP380	8"	13.41"	10.53"

For Further Information Contact



The World's Leading
Radon Fan Manufacturer



RP Series

Installation & Operating Instructions

RadonAway

3 Saber Way | Ward Hill, MA 01835

www.radonaway.com



RadonAway Ward Hill, MA.

Series Fan Installation & Operating Instructions

Please Read and Save These Instructions.

DO NOT CONNECT POWER SUPPLY UNTIL FAN IS COMPLETELY INSTALLED. MAKE SURE ELECTRICAL SERVICE TO FAN IS LOCKED IN "OFF" POSITION. DISCONNECT POWER BEFORE SERVICING FAN.

- WARNING!** WARNING! For General Ventilating Use Only. Do Not Use to Exhaust Hazardous, Corrosive or Explosive Materials, Gases or Vapors. See Vapor Intrusion Application Note #AN001 for important information on VI applications. RadonAway.com/vapor-intrusion
- WARNING!** NOTE: Fan is suitable for use with solid state speed controls however use of speed controls is not generally recommended.
- WARNING!** Check voltage at the fan to insure it corresponds with nameplate.
- WARNING!** Normal operation of this device may affect the combustion airflow needed for safe operation of fuel burning equipment. Check for possible backdraft conditions on all combustion devices after installation.
- NOTICE!** There are no user serviceable parts located inside the fan unit.
Do NOT attempt to open. Return unit to the factory for service.
- WARNING!** Do not leave fan unit installed on system piping without electrical power for more than 48 hours. Fan failure could result from this non-operational storage.
- WARNING!** TO REDUCE THE RISK OF FIRE, ELECTRIC SHOCK, OR INJURY TO PERSONS, OBSERVE THE FOLLOWING:
 - Use this unit only in the manner intended by the manufacturer. If you have questions, contact the manufacturer.
 - Before servicing or cleaning unit, switch power off at service panel and lock the service disconnecting means to prevent power from being switched on accidentally. When the service disconnecting means cannot be locked, securely fasten a prominent warning device, such as a tag, to the service panel.
 - Installation work and electrical wiring must be done by qualified person(s) in accordance with all applicable codes and standards, including fire rated construction.
 - Sufficient air is needed for proper combustion and exhausting of gases through the flue (chimney) of fuel burning equipment to prevent back drafting. Follow the heating equipment manufacturers guideline and safety standards such as those published by the National Fire Protection Association, and the American Society for Heating, Refrigeration and Air Conditioning Engineers (ASHRAE), and the local code authorities.
 - When cutting or drilling into a wall or ceiling, do not damage electrical wiring and other hidden utilities.
 - Ducted fans must always be vented to outdoors.
 - If this unit is to be installed over a tub or shower, it must be marked as appropriate for the application and be connected to a GFCI (Ground Fault Circuit Interrupter) - protected branch circuit.

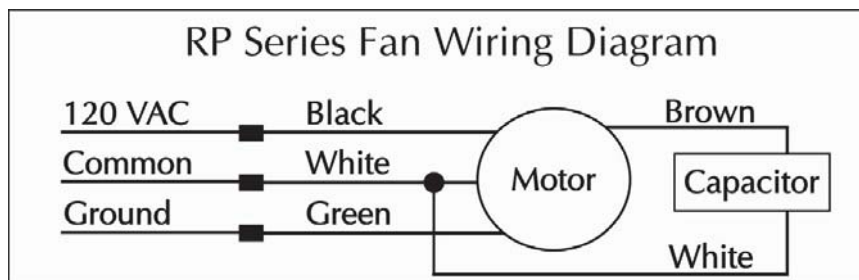



RP Series

RP140	p/n 23029-1
RP145	p/n 23030-1
RP260	p/n 23032-1
RP265	p/n 23033-1
RP380	p/n 28208

1.0 SYSTEM DESIGN CONSIDERATIONS

1.1. INTRODUCTION

The RP Series Radon Fans are intended for use by trained, professional, certified/licensed Radon mitigators. The purpose of this instruction is to provide additional guidance for the most effective use of an RP Series Fan. This instruction should be considered as a supplement to EPA/radon industry standard practices, state and local building codes and state regulations. In the event of a conflict, those codes, practices and regulations take precedence over this instruction.

1.2. FAN SEALING

The RP Series Fans are factory sealed, no additional caulk or other materials are required to inhibit air leakage.

1.3. ENVIRONMENTALS

The RP Series Fans are designed to perform year-round in all but the harshest climates without additional concern for temperature or weather. For installations in an area of severe cold weather, please contact RadonAway for assistance. When not in operation, the fan should be stored in an area where the temperature is never less than 32 degrees F. or more than 100 degrees F.

1.4. ACOUSTICS

The RP Series Fan, when installed properly, operates with little or no noticeable noise to the building occupants. The velocity of the outgoing air should be considered in the overall system design. In some cases the "rushing" sound of the outlet air may be disturbing. In these instances, the use of a RadonAway Exhaust Muffler is recommended.

(To ensure quiet operation of ENERGY STAR qualified in-line and remote fans, each fan shall be installed using sound attenuation techniques appropriate for the installation. For bathroom and general ventilation applications, at least 8 feet of insulated flexible duct shall be installed between the exhaust or supply grille(s) and the fan). RP Series fans are not suitable for kitchen range hood remote ventilation applications.

1.5. GROUND WATER

In the event that a temporary high water table results in water at or above slab level, water may be drawn into the riser pipes thus blocking air flow to the RP Series Fan. The lack of cooling air may result in the fan cycling on and off as the internal temperature rises above the thermal cutoff and falls upon shutoff. Should this condition arise, it is recommended that the fan be turned off until the water recedes allowing for return to normal operation.

1.6. SLAB COVERAGE

The RP Series Fan can provide coverage up to 2000+ sq. ft. per slab penetration. This will primarily depend on the sub-slab material in any particular installation. In general, the tighter the material, the smaller the area covered per penetration. Appropriate selection of the RP Series Fan best suited for the sub-slab material can improve the slab coverage. The RP140/145/155 are best suited for general purpose use. The RP260 can be used where additional airflow is required and the RP265/380 is best suited for large slab, high airflow applications. Additional suction points can be added as required. It is recommended that a small pit (5 to 10 gallons in size) be created below the slab at each suction hole.

1.7. CONDENSATION & DRAINAGE

Condensation is formed in the piping of a mitigation system when the air in the piping is chilled below its dew point. This can occur at points where the system piping goes through unheated space such as an attic, garage or outside. The system design must provide a means for water to drain back to a slab hole to remove the condensation. The RP Series Fan **MUST** be mounted vertically plumb and level, with the outlet pointing up for proper drainage through the fan. Avoid mounting the fan in any orientation that will allow water to accumulate inside the fan housing. The RP Series Fans are **NOT** suitable for underground burial.

For RP Series Fan piping, the following table provides the minimum recommended pipe diameter and pitch under several system conditions.

Pipe Dia.	Minimum Rise per Ft of Run*				
	@25 CFM	@50 CFM	@100 CFM	@200 CFM	@300 CFM
6"	-	3/16	1/4	3/8	3/4
4"	1/8	1/4	3/8	2 3/8	-
3"	1/4	3/8	1 1/2	-	-



*Typical RP1xx/2xx Series Fan operational flow rate is 25 - 90 CFM on 3" and 4" pipe. (For more precision, determine flow rate by measuring Static Pressure, in WC, and correlate pressure to flow in the performance chart in the addendum.)

Under some circumstances in an outdoor installation a condensate bypass should be installed in the outlet ducting as shown. This may be particularly true in cold climate installations which require long lengths of outlet ducting or where the outlet ducting is likely to produce large amounts of condensation because of high soil moisture or outlet duct material. Schedule 20 piping and other thin-walled plastic ducting and Aluminum downspout will normally produce much more condensation than Schedule 40 piping. Schedule 40 piping is preferred for radon mitigation, all joints should fully sealed using the appropriate pipe cement on socket type fittings or flexible coupling firmly attached via worm drive screw clamps. Sealing ducting or pipe with duct tape is not acceptable on radon mitigation installations. No pipe penetrations are permitted, other than the condensation bypass. Silicon caulk is permitted for sealing purposes.

The bypass is constructed with a 45 degree Wye fitting at the bottom of the outlet stack. The bottom of the Wye is capped and fitted with a tube that connects to the inlet piping or other drain. The condensation produced in the outlet stack is collected in the Wye fitting and drained through the bypass tube. The bypass tubing may be insulated to prevent freezing.

1.8. SYSTEM MONITOR & LABEL

A System Monitor, such as a manometer (P/N 50017) or audible alarm (P/N 28001-2) is required to notify the occupants of a fan system malfunction. A System Label (provided with Manometer P/N 50017) with instructions for contacting the installing contractor for service and also identifying the necessity for regular radon tests to be conducted by the building occupants, must be conspicuously placed where the occupants frequent and can see the label.

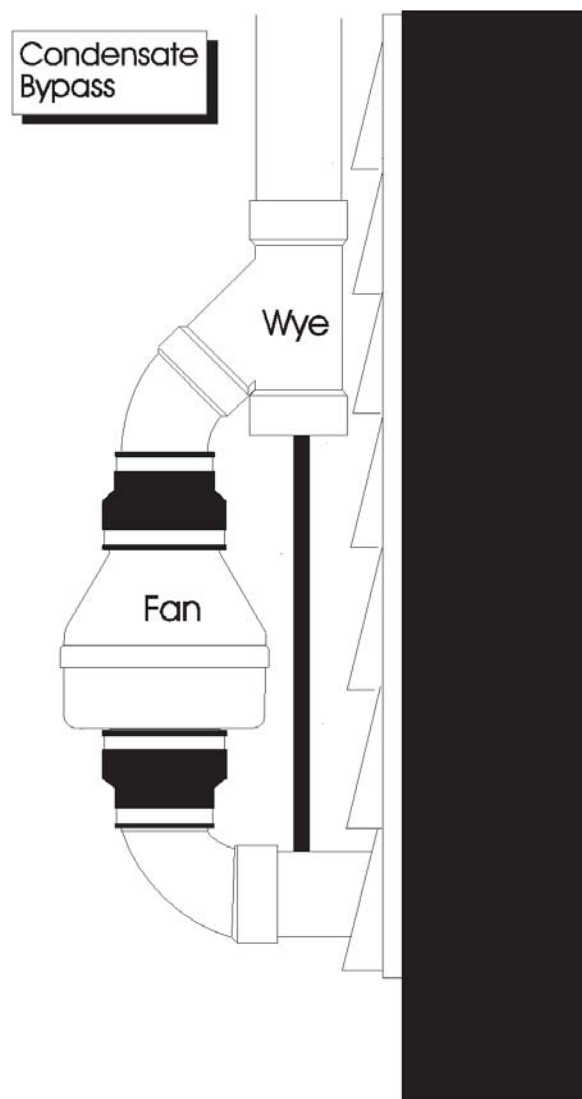

1.9. VENTILATION

If used as a ventilation Fan any type of ducting is acceptable, however, flexible nonmetallic ducting is recommended for easy installation and quieter operation. Insulated flexible ducting is highly recommended in cold climates to prevent the warm bathroom air from forming condensation in the ducting where it is exposed to colder attic air. The outlet of the fan should always be ducted to the outside. Avoid venting the outlet of the fan directly into an attic area. The excess moisture from the bathroom can cause damage to building structure and any items stored in the attic. Multiple venting points may be connected together using a "T" or "Y" fitting. Ideally Duct should be arranged such that equal duct lengths are used between intake and "T" or "Y" fitting, this will result in equal flow rates in each intake branch. If adjustable intake grilles are used on multi-intake systems then the opening on each grill should be equal in order to minimize noise and resistance. Straight smooth runs of rigid metal ducting will present the least resistance and maximize system performance. The Equivalent Length of Rigid Metal Ducting resulting in .2" WC pressure loss for each Fan Model is provided in the specification section of these Instructions. Flexible ducting, if used, must always be as close to being fully extended as possible. Formed rigid metal duct elbows will present the least resistance and maximize system performance, recommended bend radius of elbow is at least 1.5 x duct diameter.

RP Series fans are not suitable for kitchen range hood remote ventilation applications. For quietest performance, the fan should be mounted further away from the inlet duct, near the outside vent. A minimum distance of 8 feet is recommended between the fan or T/Y of a multi-intake system and intake grille(s).

Backdraft dampers allow airflow in only one direction preventing cold/hot drafts from entering the vented area and minimize possible condensation and icing within the system while the fan is not operating. Backdraft dampers are highly recommended at each intake grille for bathroom ventilation in all cold climate installations. Installation instructions are included with Spruce backdraft dampers.

The ducting from this fan to the outside of the building has a strong effect on the airflow, noise and energy use of the fan. Use the shortest, straightest duct routing possible for best performance, and avoid installing the fan with smaller ducts than recommended. Insulation around the ducts can reduce energy loss and inhibit mold growth. Fans installed with existing ducts may not achieve their rated airflow.

1.10. ELECTRICAL WIRING

The RP Series Fans operate on standard 120V 60 Hz. AC. All wiring must be performed in accordance with the National Fire Protection Association's (NFPA) National Electrical Code, Standard #70-current edition for all commercial and industrial work, and state and local building codes. All wiring must be performed by a qualified and licensed electrician. Outdoor installations require the use of a U.L. listed watertight conduit. Ensure that all exterior electrical boxes are outdoor rated and properly sealed to prevent water penetration into the box. A means, such as a weep hole, is recommended to drain the box.

1.11. SPEED CONTROLS

The RP Series Fans are rated for use with electronic speed controls, however, they are generally not recommended. If used, the recommended speed control is Pass & Seymour Solid State Speed Control Cat. No. 94601-I.

2.0 INSTALLATION

The RP Series Fan can be mounted indoors or outdoors. (It is suggested that EPA recommendations be followed in choosing the fan location.) The RP Series Fan may be mounted directly on the system piping or fastened to a supporting structure by means of optional mounting bracket

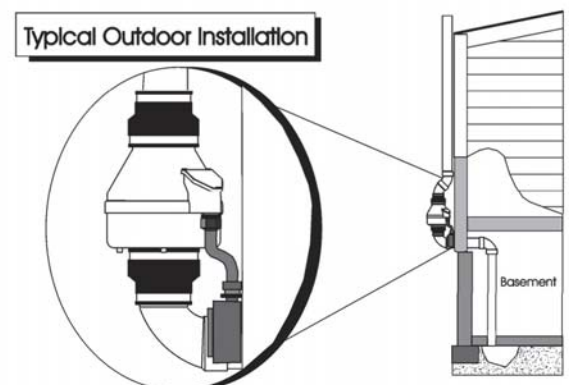

2.1 MOUNTING

Mount the RP Series Fan vertically with outlet up. Insure the unit is plumb and level. When mounting directly on the system piping assure that the fan does not contact any building surface to avoid vibration noise.

2.2 MOUNTING BRACKET (optional)

The RP Series Fan may be optionally secured with the RadonAway P/N 25007 (25033 for RP385) mounting bracket. Foam or rubber grommets may also be used between the bracket and mounting surface for vibration isolation.

2.3 SYSTEM PIPING

Complete piping run, using flexible couplings as means of disconnect for servicing the unit and vibration isolation. Used as a Radon Fan the fan is typically outside of the building thermal boundary, and is venting to the outside, installation of insulation around the fan is not required. If used as a ventilation fan insulation may be installed around the fan and duct work, insulation should be sized appropriately for the duct size used and secured with duct tape.

2.4 ELECTRICAL CONNECTION

Connect wiring with wire nuts provided, observing proper connections (See Section 1.10). Note that the fan is not intended for connection to rigid metal conduit.

Fan Wire	Connection
Green	Ground
Black	AC Hot
White	AC Common

2.5 VENT MUFFLER (optional)

Install the muffler assembly in the selected location in the outlet ducting. Solvent weld all connections. The muffler is normally installed at the end of the vent pipe.

2.6 OPERATION CHECKS & ANNUAL SYSTEM MAINTENANCE

_____ **Verify** all connections are tight and **leak-free**.

_____ **Insure** the RP Series Fan and all ducting is secure and vibration-free.

_____ **Verify** system vacuum pressure with manometer. **Insure** vacuum pressure is within normal operating range and **less than** the maximum recommended operating pressure.

(Based on sea-level operation, at higher altitudes reduce by about 4% per 1000 Feet.)

(Further reduce Maximum Operating Pressure by 10% for High Temperature environments)

See Product Specifications. If this is exceeded, increase the number of suction points.

_____ **Verify Radon levels by testing to EPA protocol.**

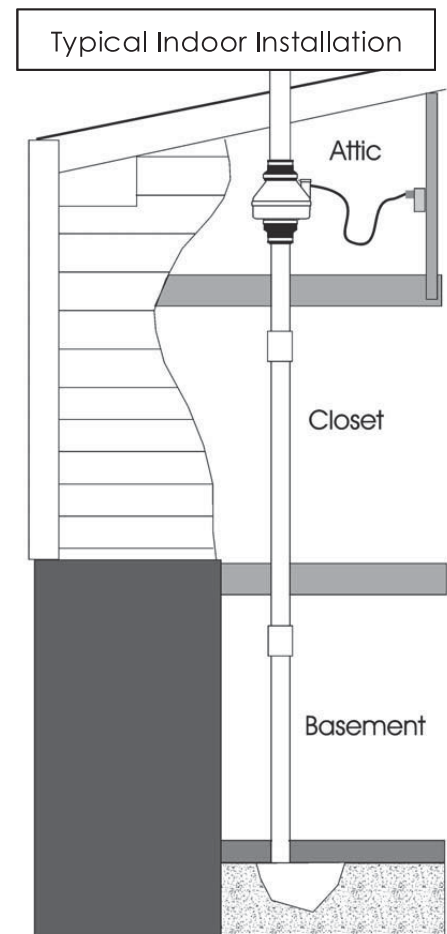

RP SERIES PRODUCT SPECIFICATIONS

The following chart shows fan performance for the RP Series Fan:

Typical CFM Vs Static Pressure "WC									
	0"	.25"	.5"	.75"	1.0"	1.25"	1.5"	1.75"	2.0"
RP140	135	103	70	14	-	-	-	-	-
RP145	166	146	126	104	82	61	41	21	3
RP260	272	220	176	138	103	57	13	-	-
RP265	334	291	247	210	176	142	116	87	52
RP380*	497	401	353	281	220	176	130	80	38

* Tested with 6" inlet and discharge pipe.

Power Consumption 120 VAC, 60Hz 1.5 Amp Maximum			Maximum Recommended Operating Pressure* (Sea Level Operation)**	
RP140	17 - 21	watts	RP140	0.8" W.C.
RP145	41 - 72	watts	RP145	1.7" W.C.
RP260	52 - 72	watts	RP260	1.5" W.C.
RP265	91 - 129	watts	RP265	2.2" W.C.
RP380	95 - 152	watts	RP380	2.0" W.C.

*Reduce by 10% for High Temperature Operation

**Reduce by 4% per 1000 feet of altitude

	Size	Weight	Inlet/Outlet	L.2
RP140	8.5H" x 9.7" Dia.	5.5 lbs.	4.5" OD (4.0" PVC Sched 40 size compatible)	25
RP145	8.5H" x 9.7" Dia.	5.5 lbs.	4.5" OD (4.0" PVC Sched 40 size compatible)	15
RP260	8.6H" x 11.75" Dia.	5.5 lbs.	6.0" OD	48
RP265	8.6H" x 11.75" Dia.	6.5 lbs.	6.0" OD	30
RP380	10.53H" x 13.41" Dia.	11.5 lbs.	8.0" OD	57

L.2 = Estimated Equivalent Length of Rigid Metal Ducting resulting in .2in WC pressure loss for Duct Size listed. Longer Equivalent Lengths can be accommodated at Flows Lower than that at .2in WC pressure loss (see CFM Vs Static Pressure "WC Table).

Recommended ducting: 3" or 4" RP1xx/2xx, 6" RP380, Schedule 20/40 PVC Pipe

Mounting: If used for Ventilation use 4", 6" or 8" Rigid or Flexible Ducting

Mount on the duct pipe or with optional mounting bracket.

Storage temperature range: 32 - 100 degrees F.

Normal operating temperature range: -20 - 120 degrees F.

Maximum inlet air temperature: 80 degrees F.

Continuous Duty

Class F Insulation [RP140 Class B]

Class B Insulation

Thermally Protected

3000 RPM

Rated for Indoor or Outdoor Use



Conforms to
UL STD. 507

Certified to
CAN/CSA STD.
C22.2 No.113



IMPORTANT INSTRUCTIONS TO INSTALLER

Inspect the GP/XP/XR/RP/SF Series Fan for shipping damage within 15 days of receipt. Notify **RadonAway® of any damages immediately**. RadonAway® is not responsible for damages incurred during shipping. However, for your benefit, RadonAway® does insure shipments.

There are no user serviceable parts inside the fan. **Do not attempt to open.** Return unit to factory for service.

Install the GP/XP/XR/RP/SF Series Fan in accordance with all EPA standard practices, and state and local building codes and state regulations.

Provide a copy of this instruction or comparable radon system and testing information to the building occupants after completing system installation.

WARRANTY

RadonAway® warrants that the GPX01/XP/XR/RP/SF Series Fan (the "Fan") will be free from defects in materials and workmanship for a period of 90 days from the date of purchase (the "Warranty Term").

RadonAway® will replace any Fan which fails due to defects in materials or workmanship during the Warranty Term. The Fan must be returned (at Owner's cost) to the RadonAway® factory. Any Fan returned to the factory will be discarded unless the Owner provides specific instructions along with the Fan when it is returned regardless of whether or not the Fan is actually replaced under this warranty. Proof of purchase must be supplied upon request for service under this Warranty.

This Warranty is contingent on installation of the Fan in accordance with the instructions provided. This Warranty does not apply where any repairs or alterations have been made or attempted by others, or if the unit has been abused or misused. Warranty does not cover damage in shipment unless the damage is due to the negligence of RadonAway®.

5 YEAR EXTENDED WARRANTY WITH PROFESSIONAL INSTALLATION.

RadonAway® will extend the Warranty Term of the fan to five (5) years from date of purchase or sixty-three (63) months from the date of manufacture, whichever is sooner, if the Fan is installed in a professionally designed and professionally installed active soil depressurization system or installed as a replacement fan in a professionally designed and professionally installed active soil depressurization system by a qualified installer. Proof of purchase and/or proof of professional installation may be required for service under this warranty. Outside the Continental United States and Canada the extended Warranty Term is limited to one (1) year from the date of manufacture.

RadonAway® is not responsible for installation, removal or delivery costs associated with this Warranty.

LIMITATION OF WARRANTY

EXCEPT AS STATED ABOVE, THE GPX01/XP/XR/RP SERIES FANS ARE PROVIDED WITHOUT WARRANTY OF ANY KIND, EITHER EXPRESS OR IMPLIED, INCLUDING, WITHOUT LIMITATION, IMPLIED WARRANTIES OF MERCHANTABILITY AND FITNESS FOR A PARTICULAR PURPOSE.

IN NO EVENT SHALL RADONAWAY BE LIABLE FOR ANY DIRECT, INDIRECT, SPECIAL, INCIDENTAL, OR CONSEQUENTIAL DAMAGES ARISING OUT OF, OR RELATING TO, THE FAN OR THE PERFORMANCE THEREOF. RADONAWAY'S AGGREGATE LIABILITY HEREUNDER SHALL NOT IN ANY EVENT EXCEED THE AMOUNT OF THE PURCHASE PRICE OF SAID PRODUCT. THE SOLE AND EXCLUSIVE REMEDY UNDER THIS WARRANTY SHALL BE THE REPAIR OR REPLACEMENT OF THE PRODUCT, TO THE EXTENT THE SAME DOES NOT MEET WITH RADONAWAY'S WARRANTY AS PROVIDED ABOVE.

For service under this Warranty, contact RadonAway for a Return Material Authorization (RMA) number and shipping information. No returns can be accepted without an RMA. If factory return is required, the customer assumes all shipping costs, including insurance, to and from factory.

*RadonAway® 3 Saber Way
Ward Hill, MA 01835 USA TEL (978) 521-3703
FAX (978) 521-3964
Email to: Returns@RadonAway.com*

Record the following information for your records:

Serial No. _____
Purchase Date _____

Appendix D

Retro-Coat™ Vapor Barrier Information



VAPOR INTRUSION SOLUTIONS

landsciencetech.com



VAPOR INTRUSION SOLUTIONS

Once thought to be only a concern associated with Brownfield redevelopments, the threat of contaminant vapor intrusion into buildings is becoming a prevalent concern for all structures. Vapor intrusion occurs when contaminant vapors are found in close proximity to a building foundation and then migrate into the enclosed space of an overlying structure.

Environmental consultants, building owners and regulators are looking to find innovative solutions to manage both the short and long-term vapor intrusion risk. As risk standards continue to evolve, engineered controls provide a practical and cost-effective solution when compared to remediating the soil to acceptable standards or collecting enough data to eliminate the risk.

Barrier technologies, alone or when combined with active or passive gas collection systems, physically block contaminated vapor from entering the structure and safely protect building occupants.



Land Science Technologies develops vapor intrusion mitigation solutions that protect people and invigorate renewal of contaminated properties. We leverage our industry expertise to assist clients in developing site specific solutions that are technically sound and cost-effective. Land Science Technologies is a division of REGENESIS, Inc., a global leader in groundwater and soil remediation technologies since 1994.



REGENESIS has been a recognized leader in the environmental industry since 1994, developing and supplying proven, innovative remediation technologies that significantly reduce the cost, time, and difficulty of restoring contaminated soil and groundwater. REGENESIS products have been used by leading multi-national environmental engineering and consulting firms on more than 20,000 soil and groundwater cleanup projects worldwide and across the USA.

For more information about Regenesys products visit, REGENESIS.COM or contact your local representative.

GEO-SEAL® PROJECTS



Townhome Development - 70,000 ft²

Student Housing - 90,000 ft²

Fast Food Restaurant - 6,000 ft²

Below Grade Waterproofing - 60,000 ft²

Big Box Retail - 150,000 ft²

Geo-Seal is a composite membrane system and is the only patented contaminant vapor barrier system in the world today. Geo-Seal combines the advantage of chemically resistant high-density polyethylene (HDPE) and the constructability benefits of spray-applied membranes. This results in one robust system that is designed specifically to mitigate contaminant vapor intrusion. Ideal for new construction, Geo-Seal has been accepted by state environmental agencies across the country, the US NAVY, US AIR FORCE, the New York School Construction Authority, Fortune 500 Companies and leading environmental consulting firms around the world.

Advantages of Geo-Seal:

- Industry leading warranty
- Composite technology provides multiple layers of protection
- Lowest diffusion rates in the industry
- Waterproofing system configurations available



RETRO-COAT™ PROJECTS



Single Family Homes - 6,000 ft²

Former Industrial - 7,000 ft²

Former Industrial - 27,000 ft²

Senior Housing - 20,000 ft²

High Density Housing - 150,000 ft²

Retro-Coat™ is a chemically resistant coating specifically designed to mitigate contaminant vapor intrusion into existing structures. Applying Retro-Coat to existing concrete slabs provides a physical barrier to contaminant vapors. When combined with an active sub-slab depressurization system, Retro-Coat will maximize the performance of the system and provide continued protection when the system is not active.

Advantages of Retro-Coat:

- Specifically formulated to mitigate PCE, TCE and Benzene vapors
- Laboratory testing shows a 6 order of magnitude reduction of contaminant vapors
- Designed to withstand foot traffic and industrial settings
- Carpet, laminate and tile floors can be placed directly on Retro-Coat
- No VOCs and fast curing process reduce building downtime

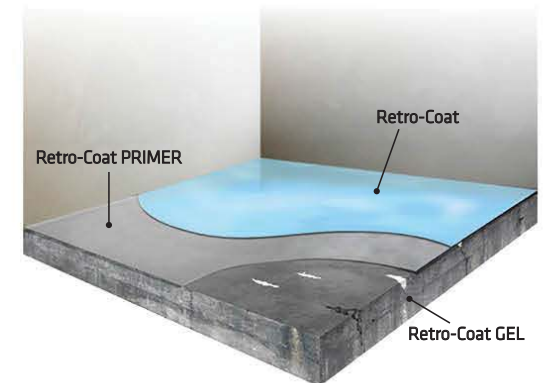

Available Colors and Finishes



GEO-SEAL® APPLICATION



Vapor-Vent should be installed in a permeable subgrade to maximize vapor collection ability



Geo-Seal BASE is a composite sheet material comprised of HDPE and non-woven geotextile



Geo-Seal CORE is spray applied to increase the systems tensile strength and provide a seamless membrane



Penetrations are sealed individually



Geo-Seal BOND is applied over the Geo-Seal CORE to provide additional protection



Concrete is placed directly onto the completed Geo-Seal system



Vapor-Vent is a low profile vapor collection system that is placed underneath a structure to passively or actively eliminate the build up of contaminant vapor. It is also an economical alternative to traditional slotted pipe systems and can be installed in a fraction of the time.

RETRO-COAT™ APPLICATION



Existing concrete slab is first cleaned and then abraded



Retro-Coat caulk and fillers are used repair concrete cracks and other imperfections



Retro-Coat PRIMER is applied to the concrete surface as final preparation



Retro-Coat is applied to a nominal thickness of 20 dry mils

Land Science Technologies

1011 Calle Sombra

San Clemente, CA 92673

landsciencetech.com

(949) 481-8118

Land Science Technologies Specifications for Retro-Coat™ Version 1.0

Part 1 – Scope

1.1 Product and Application

This specification describes the application of the Retro-Coat™ System. The minimum thickness of the system is between 25-30 mils, including a 20 mil minimum application of Retro-Coat.

1.2 Acceptable Manufacturers

- A. Retro-Coat as manufactured by Land Science Technologies San Clemente, CA.

1.3 Performance Criteria

- A. Retro-Coat as manufactured by Land Science Technologies San Clemente, CA.
 - 1. Diffusion Coefficient (Columbia Labs)
PCE: 7.6×10^{-14} m²/s
TCE: 8.2×10^{-14} m²/s
 - 2. Tensile Elongation (ASTM D-638)
Minimum: 6000 psi
 - 3. Tensile Elongation (ASTM D-638)
Minimum: 6 %
 - 4. Flexural Strength (ASTM D-790)
Minimum: 7000 psi
 - 5. Hardness, Shore D (ASTM D-2240)
Maximum: 85
 - 6. Gardner Impact (ASTM D-2794)
Minimum: 80 inch-pounds
 - 7. Bond Strength to Quarry Tile
Minimum: 1000 psi
 - 8. Vapor Transmission Rate (ASTM E-96)
Maximum: .07 perms
 - 9. Water Absorption (ASTM D-570)
Maximum: .02% in 24 hours
 - 10. 60° Gloss
Minimum: 100.

1.4 Materials

- A. Retro-Coat "A" shall be a modified epoxy containing special flexibilizers and specially formulated resins for superior chemical resistance and enhanced resilience. No solvents are allowed.
- B. Retro-Coat "B" shall be customized blend of hardeners specifically formulated to maximize chemical resistance. No solvents are allowed.

1.5 Applicator

- A. Applicator must be a certified contractor of Land Science Technologies.

Part 2 – Application

2.1 Surface Preparation

- A. All existing surfaces that will be covered with the systems specified herein should be mechanically ground, shot blasted or sand blasted to yield a minimum 60 grit surface texture. All loosely adhered coatings will be removed. Any grease and other contaminants found on the concrete must also be removed.
- B. All open cracks 1/2" and greater should be v-notched to a 3/4" width by 1/2" depth and cleaned of any debris. Such cracks should be filled with Retro-Coat Gel and struck off flush with the surrounding surface.
- C. Cut back and/or remove any expansion joint backing or filler strips to a minimum of 1 1/2" deep. Insert disposable filler in the joints to prevent filling with the overlayment materials and to allow for accurate location of final saw cuts in the overlayment.

2.2 Material Application

- A. Retro-Coat CAULK
 1. Apply Retro-Coat CAULK around the base of all pipe penetrations making sure to fill any gap between the penetration and concrete slab
 2. Apply Retro-Coat CAULK to the joint created between horizontal and vertical transitions. The caulking material should be applied and pressed into the joint filling any gaps that might be present.
- B. Retro-Coat PRIMER
 1. Apply Retro-Coat PRIMER to all areas at a thickness of 6 mil and allow to dry tack free. In areas where the concrete surface is in need of slight repair or needs to be leveled, a slurry form of Retro-Coat PRIMER called Retro-Coat PRIMER-S can be applied with a flat squeegee. Retro-Coat PRIMER-S is self priming and does not need to be primed again.
- C. Retro-Coat
 1. Mix Retro-Coat, Part A with a low-speed (<750 rpm) jiffy-style mixer for about 30 seconds, or until uniform in color, then mix in Retro-Coat Coating, Part B for another 30-60 seconds.
 2. Dump contents onto floor in a ribbon pattern, squeegee, and then back roll at a coverage rate of 160 SF/gallon to achieve a film thickness of 10 mils.
 3. Apply second coat 10 mil coat to achieve a total thickness of 20 mils. Repeat as necessary to achieve specified thickness.
 4. If a flooring material will be placed over Retro-Coat after it is applied, or appearance is not a priority, (1) 20 mil coat can be applied.

2.3 Protection of Finished Work

- A. Prohibit foot traffic on floor for 24 hours after laying (at 70°F). At 50°F, this time should be extended to 48 hours.
- B. Rinse off any chemicals that may come in contact within 7 days of installation with the freshly laid floor immediately.

2.4 Cleanup

- A. Properly dispose of all unused and waste materials.
- B. Tools can be washed in warm, soapy water when wet, but after drying, can only be cleaned by grinding or with a paint stripper.
- C. Unused resin can be set off with proper amount of hardener and disposed of in regular trash bins.

Part 3 – Quality Control

3.1 Warranty

- A. Installer shall provide a one year warranty against delamination, chemical attack and normal wear and tear.
- B. Manufacturer will provide a one year material warranty.

3.2 Quality Control

- A. Installer shall use a notched squeegee to apply Retro-Coat to the specified mil thickness and calculations shall be done to determine if the correct amount of material has been applied. Retro-Coat contains 100% solids at the time of application; therefore no material shrinkage will occur during the curing process. One gallon will cover 80 square feet.
- B. A wet mil film gauge can be used to spot check the Retro-Coat thickness to make certain the minimum 20 mil thickness has been applied, though some discretion should be used because high points or low points on the underlying surface can adversely affect the thickness measurements.

3.3 Floor Care

- A. The standard smooth surface of Retro-Coat should be cleaned on a regular basis by damp mopping the floor with conventional commercial cleaners. It is important to first remove any grease or oils by a suitable cleaner, preferably a citrus based cleaner. Rinse with clear water to help eliminate film buildup and then allow to dry. Never use abrasive powder cleaners like Ajax or Comet as they tend to scratch the floor.
- B. Additional steps can also be taken to prolong the look and life of a seamless floor:
 - 1. Protect the floor during transference of heavy equipment
 - 2. Educate the drivers inside the building the importance of avoiding "jack-rabbit" starts and stops, as well as keeping the metal forks lifted
 - 3. Regular cleaning should take place as to not allow the buildup of abrasive material, such as sand or dirt, on the coating
 - 4. Eliminate all metal wheels
 - 5. Change over to light-colored polyurethane wheels
 - 6. Do not slide heavy metal totes, drums or bins across the floor
 - 7. Immediately hose down chemical spills, especially on newly laid floors.