

Harding Lawson Associates



92 JUL 29 PM 1:03

Transmittal/Memorandum

To: Alameda County Health Care Services Agency
80 Swan Way
Room 200
Oakland, California 94621
Attention: Dr. Ravi Arulanantum

From: Mary Jo Heassler/ John C. Blasco^{MJH}
Date: July 27, 1992
Subject: Report Transmittal
Job No.: 20442 1

Remarks:

Enclosed for your review please find a copy of Harding Lawson Associates' report *Site Information Summary, 24688 Hesperian Boulevard, Hayward, California*. Also included is a \$500.00 deposit for fees associated with review of the report.

The report describes previous site remedial activities, site conditions, and contaminated properties in the site vicinity. Also presented is a qualitative discussion of potential exposure pathways for residual chemicals in soil and groundwater and an evaluation of the likelihood of significant exposure occurring during site development.

Because development of the site is awaiting your evaluation of site conditions and potential health risks, we request an opportunity to meet with you at your earliest convenience to discuss the matter. Please contact us at 415/892-0821, if you have any questions or comments.

mjh\trans\equrpt.doc

cc: Mr. James J. Hackett, Equity Properties and Development Company



September 30, 1992

20442 1

Alameda County Health Care Services Agency
80 Swan Way
Room 200
Oakland, California 94621

Attention: Dr. Ravi Arulanathan

Site Information Summary
24688 Hesperian Boulevard
Hayward, California

This letter, prepared by Harding Lawson Associates (HLA) on behalf of Equity Properties and Development Company (Equity), describes the remedial activities and current site conditions at a former service station at 24688 Hesperian Boulevard, Hayward, California (site; Plate 1). It is HLA's understanding that Equity wishes to develop the site for use as a restaurant.

In November 1991, after three years of remedial activities at the site, application for closure was made to the Hayward Fire Department (HFD). In a June 8, 1992, letter to Equity, the HFD identified several concerns relative to residual concentrations of chemicals remaining onsite. One requirement outlined in the letter was to obtain concurrence from the Alameda County Health Care Services Agency that the residual materials would not result in significant adverse human health effects.

During a discussion with Mr. John Blasco of HLA, you requested that information be submitted for your review describing previous remedial activities at the site, current site conditions, zoning, and the presence of other contaminated sites in the surrounding area. This letter is being submitted in response to that request and contains the following information:

- Chronology of remedial activities
- Description of site conditions
- Identification of zoning and contaminated properties in the surrounding area
- Discussion of potential exposure pathways for construction workers and future site occupants.

September 30, 1992
Alameda County Health Services Agency
Dr. Ravi Arulananthan
20442 1
Page 2

To facilitate review of this information, we have enclosed a check in the amount of \$500.00 as a deposit against the review fees to be assessed pursuant to Alameda County Ordinance Code Section 3-141.6.

CHRONOLOGY OF REMEDIAL ACTIVITIES

The site is a parking area that was formerly occupied by a service building, two pump islands, 7,500- and 5,000-gallon gasoline underground storage tanks (USTs), and a 280-gallon waste oil UST. The USTs and appurtenant structures were removed from the site in 1978.

In July 1988, Roper and Associates of Sacramento, California, performed a geotechnical investigation for Carl Kartcher Enterprises, Pleasanton, California. The investigation included drilling several borings at the site. A soil sample collected from a boring drilled in the vicinity of the former USTs (Plate 2) was submitted for chemical analysis.

In December 1988, HLA conducted a Phase I investigation to evaluate the presence of petroleum hydrocarbons and to assess whether any USTs were present at the site. During the Phase I investigation, HLA conducted a geophysical survey to identify any existing USTs or underground utilities at the site. HLA also drilled three soil borings in the vicinity of the former USTs, one in the vicinity of the former pump islands, and one adjacent to a geophysical anomaly that indicated the possible location of the 280-gallon waste oil UST. Soil samples collected from each of the soil borings were submitted for chemical analysis. Plate 2 illustrates the locations of the five soil borings, and Plate 3 shows the locations of the geophysical anomalies identified by HLA.

Because petroleum hydrocarbons were detected in soil and groundwater samples collected during HLA's Phase I investigation, a second investigation was conducted in April 1989. The purpose of this investigation was to evaluate beneficial uses of groundwater in the site vicinity, identify potential offsite sources of contamination, and assess the impact of detected hydrocarbons on the local groundwater quality. Work performed included conducting an agency file review; drilling, installing, developing, and sampling three groundwater monitoring wells; and evaluating the local groundwater gradient and flow direction. Plate 4 shows the locations of the three monitoring wells.

In August 1990, HLA conducted a soil excavation program to assess if a waste oil UST was present at the site and remove petroleum hydrocarbon-bearing soil identified during the Phase I and II investigations. Soil was excavated in the vicinity of the former USTs, pump islands, and geophysical anomalies. After excavation was completed, confirmation soil samples collected from the walls and floors of the excavations (Plate 5) were analyzed by an onsite mobile laboratory for TPH as gasoline and benzene, toluene, ethylbenzene, and xylenes (BTEX). Excavated soil was sampled and disposed at Vasco Road Sanitary Landfill, and the excavations were backfilled with imported pea gravel and Class II aggregate. Between October 1990 and July 1991, HLA conducted a quarterly groundwater level monitoring and groundwater sampling program at the site.

September 30, 1992
Alameda County Health Services Agency
Dr. Ravi Arulananthan
20442 1
Page 3

DESCRIPTION OF SITE CONDITIONS

Site Hydrogeology

Information gathered during the Phase I and II investigations indicates that the site is underlain by approximately 23 to 25 feet of fine-grained soil comprised of clay, silt, and sandy silt. Coarser sediments comprised of silty sand or clayey gravel were encountered below depths of 23 to 25 feet. Groundwater has been measured in wells at the site at depths ranging from 16 to 20 feet (Table 1). Groundwater at the site appears to flow west to southwest (Plate 6).

Underground Storage Tanks

It appears that USTs are no longer present at the site. Excavations at the locations of geophysical anomalies did not reveal any evidence of USTs.

Distribution of Petroleum Hydrocarbons in the Subsurface

Laboratory analyses of the soil sample collected by Roper and Associates and samples collected during HLA's Phase I and II investigations indicate that soil west of the former pump islands and northwest of the former USTs contained total petroleum hydrocarbons (TPH) as gasoline at concentrations that ranged from 1.8 to 870 milligrams per kilogram (mg/kg). Soil samples collected from borings drilled in the vicinity of the former tank field did not contain detectable concentrations of petroleum hydrocarbons. Table 2 summarizes analytical results of soil samples collected by HLA and Roper and Associates.

Laboratory analyses of confirmation soil samples collected following the soil remediation program showed that no petroleum constituents were detected in floor and sidewall samples collected from the area of the former USTs. Analyses of soil samples collected from the excavation in the vicinity of the former pump islands showed TPH as gasoline concentrations ranging from non detect to 3.4 mg/kg. Table 3 summarizes the analytical results of confirmation soil samples. Only two samples, collected at depths of 12.5 and 15.5 feet, contained detectable concentrations of TPH as gasoline (3.0 and 3.4 mg/kg). Toluene was detected in soil samples collected from depths of 1.5 and 15 to 16.0 feet at concentrations ranging from 0.006 to 0.0013 mg/kg. Xylenes were detected in three samples collected at depths between 14.5 and 16.5 feet at concentrations ranging between 0.007 and 0.023 mg/kg. The results of confirmation soil sampling indicate that soil containing elevated levels of petroleum hydrocarbons had been effectively removed from the site.

During four groundwater monitoring events, TPH as gasoline and ethylbenzene were not detected in any of the three wells sampled. Benzene, toluene, and total xylenes were detected in a groundwater sample collected from Well MW-1 during the April 23, 1991, sampling event at concentrations of 0.0011, 0.0023, and 0.0008 milligrams per liter (mg/l), respectively. Table 4 presents analytical results of groundwater samples collected during HLA's groundwater monitoring program.

September 30, 1992
Alameda County Health Services Agency
Dr. Ravi Arulananthan
20442 1
Page 4

Chloroform, 1,1,1-trichloroethane (TCA), 1,2-dichlorobenzene, 1,1-dichloroethene (1,1-DCE), and dichlorofluoroethane were detected in groundwater samples collected from the monitoring wells; TCA, DCE and dichlorofluoroethane were detected in upgradient well MW-3. Because these chlorinated compounds have been detected in Well MW-3, upgradient of the former fuel storage and distribution systems, it appears that the detected chlorinated compounds may be derived from an upgradient source.

ZONING, BENEFICIAL USES OF GROUNDWATER, AND CONTAMINATED PROPERTIES IN SURROUNDING AREA

Zoning

Review of Alameda County Assessor's records indicates that the site is zoned for a shopping center. Surrounding properties are zoned for residential, bank, and office use.

Groundwater Usage

Review of a 1989 Alameda County bay plain groundwater study well inventory report indicates that water wells within 1/2 mile of the site are used for irrigation, domestic, or groundwater monitoring purposes. Well depths range from 32 to 581 feet, and depth to groundwater has been measured between 16 and 90 feet. According to the City of Hayward Public Works Department, 100 percent of the water supplied by the City of Hayward is derived from water imported from Hetch Hetchy Reservoir in the Sierra Nevada.

Contaminated Properties

HLA reviewed regulatory agency lists that identify properties with documented hazardous materials releases or store hazardous materials. The lists reviewed by HLA are:

- o **U.S. Environmental Protection Agency (U.S. EPA) National Priorities List (NPL) for Uncontrolled Hazardous Waste Sites, February 1992**

The NPL lists federal Superfund sites. There are no properties on this list within 1/2 mile of the site.

- o **U.S. EPA Comprehensive Environmental Response, Compensation, and Liability Information System (CERCLIS), April 1992**

CERCLIS assesses properties that may become federal Superfund sites. There are no properties on this list within 1/2 mile of the site.

September 30, 1992
Alameda County Health Services Agency
Dr. Ravi Arulananthan
20442 1
Page 5

o **U.S. EPA Resources Conservation and Recovery Act (RCRA) List, November 1988**

RCRA provides the names of businesses that are registered as generator, treatment, storage, or disposal facilities for hazardous wastes. There are six properties on this list within 1/2 mile of the site. These properties are listed below.

- Alameda County, 951 Turner Court
- Firestone, 715 La Playa Drive
- Gene's Norge Cleaners, 23958 Hesperian Boulevard
- Pacific Bell, 24742 La Playa Drive
- Pacific Bell, 1580 Chabot Court
- St. Rose Hospital, 27200 Calaroga Avenue

o **California Regional Water Quality Control Board (RWQCB), San Francisco Bay Region Fuel Leaks, March 1992**

The RWQCB Fuel Leaks List includes properties where fuel releases are reported to have occurred, primarily from underground storage tanks (USTs). There are six properties on this list within 1/2 mile of the site. These sites are discussed in the following section.

o **California Regional Water Quality Control Board (RWQCB), San Francisco Bay Region Toxic Sites Investigations, May 1992**

The RWQCB Active Toxics Sites Investigations includes properties where toxic substance releases are reported to have occurred. There are no properties on this list within 1/2 mile of the site.

o **California Waste Management Board (CWMB) List of Active and Inactive Landfills for Alameda County, January 1992**

The CWMB List contains the names of active and inactive landfills in the Solid Waste Information System (SWIS). There are no properties on this list within 1/2 mile of the site.

o **California Environmental Protection Agency (Cal EPA) CalSites, March 1992**

The CalSites List cites properties that have been tracked as having potential historical hazardous materials use that may require mitigation. There are four properties on this list within 1/2 mile of the site. These sites are listed below.

- Sweanngin Trucking, 23500 Odom Drive
- Armstrong Mass Painting and Sandblasting,
24984 Calaroga Avenue
- South County Community College District,
25555 Hesperian Boulevard
- St. Rose Hospital, 272 Calaroga Avenue

September 30, 1992
Alameda County Health Services Agency
Dr. Ravi Arulananthan
20442 1
Page 6

o **Hazardous Waste and Substances Site List (Cortese List), November 1990**

The Cortese List is compiled by the California State Office of Planning and Research and provides information regarding identified hazardous waste/substance sites within the state. There are six properties on the list within 1/2 mile of the site. These sites are discussed in the following section.

o **State Bond Expenditure Plan for the Hazardous Substance Cleanup Bond Act of 1984, January 1990**

The State Bond Expenditure Plan list compiled by the DTSC identifies hazardous waste sites in the state that have been targeted for cleanup by responsible parties, the DTSC, or the U.S. EPA for the next 5 fiscal years. There are no properties on this list within 1/2 mile of the site.

o **State Water Resources Control Board (SWRCB) Hazardous Substance Storage Container Information for Alameda County, June 1988**

The SWRCB Hazardous Substance Storage Container Information for Alameda County identifies underground containers (e.g., USTs) by owner and provides information on container type, year installed, capacity, piping, leak detection, and the chemical composition of the product reported to be stored in the container. There are nine properties with registered underground containers on this list within 1/2 mile of the site. These properties and registered tanks are listed below.

-- Hayward T.S.P., 24742 La Playa Place

1,000-gallon diesel tank

-- Alameda County Corporation Yard #4, 951 Turner Court

1,000-gallon solvent tank
5,000-gallon gasoline tank
5,000-gallon gasoline tank
8,000-gallon gasoline tank
10,000-gallon diesel tank
Waste oil tank

-- Southland Chevron, 24350 Hesperian Boulevard

9,500-gallon gasoline tank
5,000-gallon gasoline tank
6,000-gallon gasoline tank

September 30, 1992
Alameda County Health Services Agency
Dr. Ravi Arulanathan
20442 1
Page 7

- Winton Beacon, 94 West Winton
 - 10,000-gallon gasoline tank
 - 10,000-gallon gasoline tank
 - 10,000-gallon empty tank

- Firestone #3669, 1078 La Playa Drive
 - Waste oil tank
 - 500-gallon waste oil tank

- Ranch 10, 2498 Hesperian Boulevard
 - 550-gallon gasoline tank

- Chabot College, 25555 Hesperian Boulevard
 - 1,000-gallon gasoline tank
 - 1,000-gallon gasoline tank

- Sunnyside Nurseries - 24934 Mohr Drive
 - 7,500-gallon diesel tank
 - 10,000-gallon gasoline tank

- Texaco, 23990 Hesperian Boulevard
 - 6,000-gallon gasoline tank
 - 4,000-gallon gasoline tank
 - 4,000-gallon gasoline tank
 - 2,000-gallon gasoline tank
 - 550-gallon waste oil tank

September 30, 1992
Alameda County Health Services Agency
Dr. Ravi Arulananthan
20442 1
Page 8

File Review

HLA reviewed RWQCB fuel leak files for properties identified from review of the Fuel Leaks and Cortese lists. Locations of the six sites are shown on Plate 7. A discussion follows of the results of the file review of the sites neighboring the Equity property.

**Chevron Station 9-5416
24350 Hesperian Boulevard**

The Chevron station is approximately 1/4 mile north and crossgradient of the Equity site. Nine wells have been installed to monitor site groundwater conditions at the Chevron station. Review of a groundwater monitoring report dated February 1992 indicates that TPH as gasoline and benzene have been detected in groundwater samples at maximum concentrations of 49 and 3 mg/l, respectively. Free-phase petroleum product has been measured in one well at thicknesses up to 0.29 foot. Measured depth to water in groundwater monitoring wells has ranged from 20 to 27 feet below ground surface, and the general direction of groundwater flow at the Chevron site is to the southwest.

**Former Citgo Station
660 West Winton Avenue**

The former Citgo Station is approximately 1/2 mile northeast and upgradient of the Equity site. In March 1985 and March 1992, three 10,000-gallon gasoline USTs, six 1,000-gallon waste oil USTs, and one 2,000-gallon bulk oil UST were removed from the Citgo site. As part of a groundwater investigation, 12 monitoring wells were installed at the Citgo station in 1985 and 1986. Review of groundwater monitoring data indicates that free-phase petroleum product has been detected in 6 of the 12 Citgo wells. TPH as gasoline and benzene have been detected in groundwater samples at maximum concentrations of 280 and 26 mg/l, respectively. (Groundwater samples collected from the site have not been analyzed for chlorinated compounds.) The calculated direction of local groundwater flow at the Citgo station is to the southwest.

**Ferrer Property
944 West Winton Avenue**

The Ferrer Property is approximately 3/8 mile north and crossgradient of the Equity site. In May 1987, three 1,000-gallon fuel USTs were removed from the Ferrer Property, and, in June 1987, a monitoring well was installed adjacent to the former UST locations. Review of laboratory analyses of soil samples collected from the well boring indicates that the maximum detected concentrations of TPH as gasoline and benzene were 4.0 and 0.11 mg/kg, respectively. TPH as gasoline and benzene were detected in a groundwater sample collected from the well at concentrations of 1.1 and 0.004 mg/l, respectively.

September 30, 1992
Alameda County Health Services Agency
Dr. Ravi Arulananthan
20442 1
Page 9

Chabot College
25555 Hesperian Boulevard

Chabot College is approximately 3/8 mile southwest and downgradient of the Equity site. In the 1970s, two 1,000-gallon USTs were installed at Chabot College to replace a former leaking UST. In 1986, a monitoring well was installed within 10 feet of the USTs, and, in 1990, three additional monitoring wells were installed at the Chabot site. Analyses of groundwater samples collected from the four wells indicated that TPH was detected in the well adjacent to the tanks at a maximum detected concentration of 198 mg/l. Petroleum hydrocarbons were not detected in groundwater samples collected from the other three wells. In 1991, the two USTs were removed from the Chabot site, and petroleum-bearing soil was excavated from the vicinity of the former USTs. Confirmation samples collected following excavation indicated that benzene was present in soil adjacent to the UST excavation at a concentration of 0.360 mg/kg. A french drain system was reportedly constructed in the excavation, and a fourth well was installed downgradient of the former USTs. Since the soil remediation program was completed, petroleum hydrocarbons have not been detected in groundwater samples collected from the onsite wells. The general direction of groundwater flow at the Chabot site is south to southwest.

Former Texaco Station
23390 Hesperian Boulevard

The former Texaco station is approximately 1/2 mile northwest and crossgradient of the Equity site. In 1985, preexisting USTs were removed and replaced with double-walled tanks containing fuel and waste oil. Five onsite and two offsite monitoring wells have been installed to evaluate subsurface conditions in the vicinity of the former Texaco station. TPH as gasoline and benzene have been detected in soil samples collected from well borings at maximum concentrations of 190 and 0.53 mg/kg, respectively. Maximum detected concentrations of TPH as gasoline and benzene in groundwater have been 140 and 11 mg/l. The direction of groundwater flow at the Texaco site is west to northwest.

POTENTIAL EXPOSURE PATHWAYS

The mere presence of residual concentrations of chemicals in soil and groundwater at the project site will not necessarily result in a potential health risk to construction workers, future employees, or customers of the proposed restaurant. A health risk will only occur if pathways exist that allow migration of chemicals to locations where these groups can be exposed to concentrations capable of causing adverse health effects. The following paragraphs discuss the potential exposure pathways for chemicals present at the project site and the likelihood of workers or future site users receiving significant exposures through those pathways.

September 30, 1992
Alameda County Health Services Agency
Dr. Ravi Arulananthan
20442 1
Page 10

Potential Exposure Pathways For Construction Workers

Potential exposure pathways for construction workers include the following:

- Dermal contact with chemicals in soil
- Inhalation of vapors or particulates from chemicals in soil
- Incidental ingestion of chemicals in soil
- Dermal contact with chemicals in groundwater
- Inhalation of vapors from chemicals in groundwater
- Ingestion of chemicals in groundwater.

Because groundwater is below the maximum anticipated depth of excavation for building construction of approximately 5 feet (typical for slab-on-grade construction), there will be no dermal contact with groundwater. Because onsite groundwater is not a source of drinking water, there will also be no exposure to chemicals in groundwater through the ingestion pathway. Therefore, potential exposure pathways for construction workers are limited to those associated with soil and from inhalation of vapor from groundwater.

As indicated in Table 5, residual concentrations of petroleum constituents have only been detected at depths of 12.5 feet or greater, with the exception of 0.013 ppm toluene measured at one location under the former pipeline at a depth of 1.5 feet. Other non-petroleum constituents are present in groundwater but not in onsite soil. Therefore, direct contact between construction workers and chemical-bearing soil would be limited to a concentration of 0.013 ppm toluene in a limited area of the site.

Potential Exposure Pathways For Employees and Customers

Once construction is completed, the site will be covered by the restaurant building, paved parking areas and walkways, and relatively small areas of landscaping. Because landscaped areas typically receive up to 1 foot of imported topsoil prior to planting, there will be no potential for direct contact with or ingestion of chemical-bearing soil. The only potential soil-related exposure pathway will be potential exposure to volatile constituents that migrated through the vadose zone, then through paved surfaces, building foundations, or landscaped areas. Because groundwater is not an onsite drinking water supply and there is no direct groundwater contact, potential exposure from groundwater would also be limited to exposure to migrating volatile constituents at the ground surface.

September 30, 1992
Alameda County Health Services Agency
Dr. Ravi Arulanathan
20442 1
Page 11

Likelihood Of Significant Exposures

Concentrations of chemicals in soil or groundwater onsite that could potentially contribute to migration of volatile constituents through the soil column to the ground surface are summarized in Table 5. The following media-specific exposure standards or guidelines are also summarized:

- Groundwater Maximum Contaminant Level (MCL) or Action Level (lowest federal or state value cited)
- California Applied Action Level (AAL) for soil and air
- RCRA Action Level for soil from the proposed RCRA corrective action regulations
- Permissible Exposure Limit (PEL) or Threshold Limit Value (TLV) for occupational airborne exposure (lowest state or federal value cited).

Evaluation of site-specific soil and groundwater data presented in Table 5 indicate that these concentrations are all very low. Only two of the nine chemicals detected in groundwater during the 1-year monitoring period were detected in the latest sampling round (TCA and dichlorodifluoroethane). The maximum concentrations detected in groundwater at any time during the 1-year monitoring period are all below or within one order of magnitude of drinking water standards (where available). It is extremely unlikely that these levels could cause migration of volatile constituents from groundwater to the ground surface high enough to result in exceeding an occupational exposure standard or human health guideline.

Residual levels of petroleum constituents in soil are also extremely low. The maximum levels of gasoline (3.4 mg/kg at 15.5 feet below ground surface), toluene (0.013 mg/kg at 1.5 feet below ground surface), and total xylenes (0.023 mg/kg at 15.5 feet below ground surface) are extremely unlikely to produce concentrations of volatile constituents at the ground surface that could potentially result in adverse health effects, or in the case of toluene, adverse effects through limited dermal exposure.

SUMMARY AND CONCLUSIONS

Underground tanks and appurtenant structures were removed from the site in 1978. Remediation of petroleum hydrocarbons in soil at the former gasoline service station site at 24688 Hesperian Boulevard, Hayward, California, took place in August 1990, and groundwater monitoring was performed for 1 year following remediation. Very low levels of petroleum constituents remain in onsite soil, mostly at depths greater than 12 feet below ground surface. The most recent groundwater sampling identified only two chlorinated compounds at low levels, both believed to be originating offsite.

September 30, 1992
Alameda County Health Services Agency
Dr. Ravi Arulananthan
20442 1
Page 12

Because these residual constituents are present at low levels, and because the constituents are separate from construction workers and future site occupants, significant exposures are extremely unlikely to result from the presence of these materials under the current site development plans. Therefore, the presence of these materials should not preclude the planned development of the site as a restaurant.

We trust that this letter provides the information you require at this time. Because development of the site is awaiting resolution of this issue and Equity is anxious to proceed, we request the opportunity to meet with you at your earliest convenience to discuss this matter further.

Yours very truly,
HARDING LAWSON ASSOCIATES

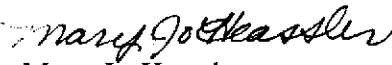
Mary Jo Heassler
Project Geologist

Michael L. Siembieda
Associate Geologist

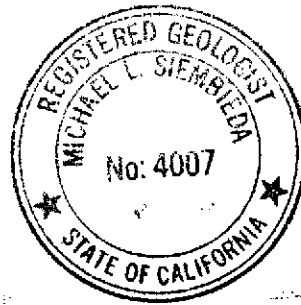

Attachments:

- Table 1 - Potentiometric Elevations
- Table 2 - Analytical Results of Soil Sampling; Roper and Associates and HLA Phase I and II Investigations
- Table 3 - Analytical Results of Confirmation Soil Samples
- Table 4 - Analytical Results of Groundwater Sampling
- Table 5 - Summary of Maximum Detected Chemical Concentrations and Standards

- Plate 1 - Area Map
- Plate 2 - Site Map/Soil Boring Locations
- Plate 3 - Ground Penetrating Radar (GPR) and Electromagnetic (EM) Anomalies
- Plate 4 - Monitoring Well Locations
- Plate 5 - Excavation and Confirmation Sample Locations
- Plate 6 - Potentiometric Surface Contours - 7/22/91
- Plate 7 - Fuel Leak Sites

cc: Mr. James Hackett, Equity Properties and Development Company
Mr. Hugh Murphy, Hayward Fire Department

**Table 1. Potentiometric Elevations
Equity Properties, Hayward, California**

Well Number	Date	Top of Well Casing Elevation (ft MSL)**	Depth Water BTOC* (feet)	Potentiometric Elevation (ft MSL)**
MW-1	5/5/89	196.26	16.08	180.18
	10/22/90	196.26	18.27	177.99
	1/11/91	196.26	18.45	177.81
	4/23/91	196.26	16.81	179.45
	7/22/91	196.26	17.53	178.73
MW-2	5/5/89	196.41	16.19	180.22
	10/22/90	196.41	18.39	178.02
	1/11/91	196.41	18.69	177.72
	4/23/91	196.41	16.94	179.47
	7/22/91	196.41	17.65	178.76
MW-3	5/5/89	197.92	17.54	180.38
	10/22/90	197.92	19.75	178.17
	1/11/91	197.92	19.92	178.00
	4/23/91	197.92	18.32	179.60
	7/22/91	197.92	18.00	179.92

* BTOC - Below top of casing

** Elevations relative to mean sea level

**Table 2. Analytical Results of Soil Sampling
Roper and Associates and HLA Phase I and II Investigations
Equity Properties, Hayward, California**

Boring/Well Number	Date	Sample Depth (feet)	TPH as Gasoline	Benzene	Toluene	Ethylbenzene	Xylenes
Roper and Associates	-	-	870	-	-	-	-
B-1	12/20/88	15.0	<0.5	<0.1	<0.1	<0.2	<0.7
B-2	12/20/88	16.0	<0.5	<0.1	0.19	0.80	0.25
B-3	12/20/88	16.0	9.1	<0.1	<0.1	<0.2	<0.7
B-4	12/20/88	16.0	<0.5	<0.1	<0.1	<0.2	<0.7
B-5	12/20/88	17.0	<0.5	<0.1	<0.1	<0.2	<0.7
B-6/MW-1	03/21/89	16.0	<0.5	<0.02	<0.02	<0.04	<0.05
B-7/MW-2	03/21/89	16.0	1.8	<0.02	<0.02	<0.04	<0.05
B-8/MW-3	03/22/89	15.5	<0.5	<0.02	<0.02	<0.04	<0.05

Results reported in milligrams per kilograms (mg/kg)

Values preceded by "<" indicate that the analyte was not detected at the indicated detection unit.

- Data not available

**Table 3. Analytical Results of Confirmation Soil Samples
August 2-3, 1991
Equity Properties, Hayward, California**

Harding Lawson Associates

Sample Location	Sampling Depth (feet)	Sample Location	Sampling Date	Sample ID	Sample Number*	TPH (gasoline)	Benzene	Toluene	Ethylbenzene	Xylenes
Excavation 1	5.5	Sidewall	8/2/90	9008-0201	1	<1.0	<0.0025	<0.0025	<0.0025	<0.0025
Excavation 1	10.5	Sidewall	8/2/90	9008-0202	2	<1.0	<0.0025	<0.0025	<0.0025	<0.0025
Excavation 1	5.0	Sidewall	8/2/90	9008-0203	3	<1.0	<0.0025	<0.0025	<0.0025	<0.0025
Excavation 1	10.0	Floor	8/2/90	9008-0204	4	<1.0	<0.0025	<0.0025	<0.0025	<0.0025
Excavation 1	14.5	Sidewall	8/2/90	9008-0205	5	<1.0	<0.0025	<0.0025	<0.0025	<0.0025
Excavation 1	15.0	Floor	8/2/90	9008-0206	6	<1.0	<0.0025	<0.0025	<0.0025	<0.0025
Excavation 1	10.5	Sidewall	8/2/90	9008-0207	7	<1.0	<0.0025	<0.0025	<0.0025	<0.0025
G.P.R. #1	5.5	Floor	8/2/90	9008-0208	8	<1.0	<0.0025	<0.0025	<0.0025	<0.0025
G.P.R. #2	8.0	Floor	8/2/90	9008-0209	9	<1.0	<0.0025	<0.0025	<0.0025	<0.0025
G.P.R. #3	7.0	Floor	8/2/90	9008-0210	10	<1.0	<0.0025	<0.0025	<0.0025	<0.0025
Excavation 2	5.0	Floor	8/2/90	9008-0211	11	<1.0	<0.0025	<0.0025	<0.0025	<0.0025
Excavation 2	5.0	Sidewall	8/2/90	9008-0212	12	<1.0	<0.0025	<0.0025	<0.0025	<0.0025
Excavation 2	14.5	Floor	8/2/90	9008-0213	13	<1.0	<0.0025	<0.0025	<0.0025	0.013
Excavation 2	15.5	Floor	8/2/90	9008-0214	14	3.4	<0.0025	<0.0025	<0.0025	0.023
Excavation 2	12.5	Sidewall	8/3/90	9008-0315	15	3.0	<0.0025	<0.0025	<0.0025	<0.0025
Excavation 2	11.5	Floor	8/3/90	9008-0316	16	<1.0	<0.0025	<0.0025	<0.0025	<0.0025
Excavation 2	16.5	Floor	8/3/90	9008-0317	17	<1.0	<0.0025	<0.0025	<0.0025	0.007
Excavation 2	17.0	Floor	8/3/90	9008-0318	18	<1.0	<0.0025	<0.0025	<0.0025	<0.0025
Excavation 2	15.5	Sidewall	8/3/90	9008-0319	19	<1.0	<0.0025	0.006	<0.0025	<0.0025
Excavation 2	15.0	Sidewall	8/3/90	9008-0328	28	<1.0	<0.0025	<0.0025	<0.0025	<0.0025
Beneath Pipeline	1.5	Floor	8/3/90	9008-0329	29	<1.0	<0.0025	0.013	<0.0025	<0.0025
Excavation 3	16.0	Floor	8/3/90	9008-0330	30	<1.0	<0.0025	0.013	<0.0025	<0.0025
Excavation 3	15.5	Sidewall	8/3/90	9008-0331	31	<1.0	<0.0025	0.009	<0.0025	<0.0025
Excavation 3	15.0	Sidewall	8/3/90	9008-0332	32	<1.0	<0.0025	0.009	<0.0025	<0.0025

Results reported in milligrams per kilograms (mg/kg)

Values preceded by "<" indicate that the analyte was not detected at the indicated detection limit.

* Sample numbers are keyed to numbers on Plate 5.

**Table 4. Analytical Results of Groundwater Sampling
Equity Properties, Hayward, California**

Well Number	Sample Date	TPH as Gasoline	Benzene	Toluene	Ethylbenzene	Total Xylenes	EPA Method 601 Parameters*				
							1,1,1-Trichloroethane	1,2-Dichlorobenzene	1,1-Dichloroethene	Chloroform	Dichlorodifluoroethane
MW-1	5/5/89	<0.002	<0.0001	<0.0001	<0.0001	<0.0001	0.0028	0.014	<0.0002	0.0019	<0.0002
	10/22/90	<0.05	<0.0005	<0.0005	<0.0005	<0.0005	NT	NT	NT	NT	NT
	1/11/91	<0.05	<0.0005	<0.0005	<0.0005	<0.0005	0.0005	<0.0004	<0.0004	<0.0004	<0.0004
	4/23/91	<0.05	0.0011	0.0023	<0.0005	0.0008	0.0007	<0.0004	<0.0004	<0.0004	<0.0004
	7/22/91	<0.05	<0.0005	<0.0005	<0.0005	<0.0005	0.0005	<0.0004	<0.0004	<0.0004	0.0013
MW-2	5/5/89	0.18	<0.0001	0.00025	<0.0001	<0.0001	NT	NT	NT	NT	NT
	10/22/90	<0.05	<0.0005	<0.0005	<0.0005	<0.0005	NT	NT	NT	NT	NT
	10/22/90 **	<0.05	<0.0005	<0.0005	<0.0005	<0.0005	NT	NT	NT	NT	NT
	1/11/91	<0.05	<0.0005	<0.0005	<0.0005	<0.0005	0.0012	<0.0004	0.0041	<0.0004	<0.0004
	1/11/91 **	<0.05	<0.0005	<0.0005	<0.0005	<0.0005	0.0023	<0.0004	0.022	<0.0004	<0.0004
	4/23/91	<0.05	<0.0005	<0.0005	<0.0005	<0.0005	0.0024	<0.0004	<0.0004	<0.0004	<0.0004
	4/23/91 **	<0.05	<0.0005	<0.0005	<0.0005	<0.0005	0.0023	<0.0004	<0.0004	<0.0004	<0.0004
	7/22/91	<0.05	<0.0005	<0.0005	<0.0005	<0.0005	0.0016	<0.0004	<0.0004	<0.0004	<0.0004
7/22/91 **	<0.05	<0.0005	<0.0005	<0.0005	<0.0005	0.0015	<0.0004	<0.0004	<0.0004	<0.0004	
MW-3	5/5/89	<0.002	<0.0001	<0.0003	<0.0001	<0.0001	NT	NT	NT	NT	NT
	10/22/90	<0.05	<0.0005	<0.0005	<0.0005	<0.0005	NT	NT	NT	NT	NT
	1/11/91	<0.05	<0.0005	<0.0005	<0.0005	<0.0005	0.0006	<0.0004	0.0027	<0.0004	<0.0004
	4/23/91	<0.05	<0.0005	<0.0005	<0.0005	<0.0005	0.0009	<0.0004	<0.0004	<0.0004	<0.0004
	7/22/91	<0.05	<0.0005	<0.0005	<0.0005	<0.0005	0.0007	<0.0004	<0.0004	<0.0004	0.011

Results reported in milligrams per liter (mg/l)

* All other EPA Method 601 parameters were not detected.

** Duplicate Water Sample

NT Not Tested

(<) symbol indicates that the analyte was not detected at the indicated detection limit.

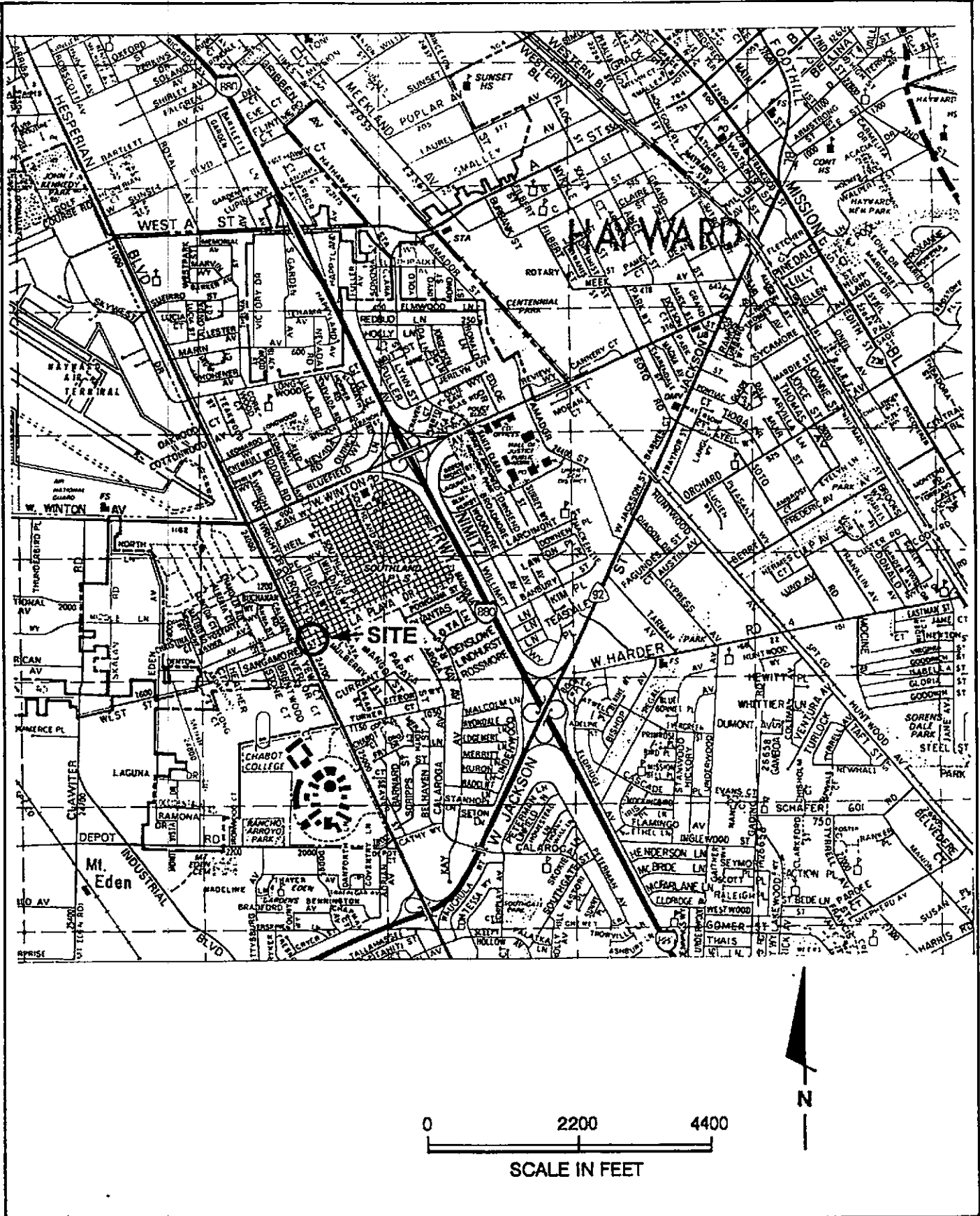

Harding Lawson Associates
 Engineering and
 Environmental Services

Area Map
 Equity Properties
 24688 Hesperian Boulevard
 Hayward, California

PI AT1

1

DRAWN
DC

JOB NUMBER
20354 1

APPROVED
MLH

DATE
7/92

REVISED

DATE

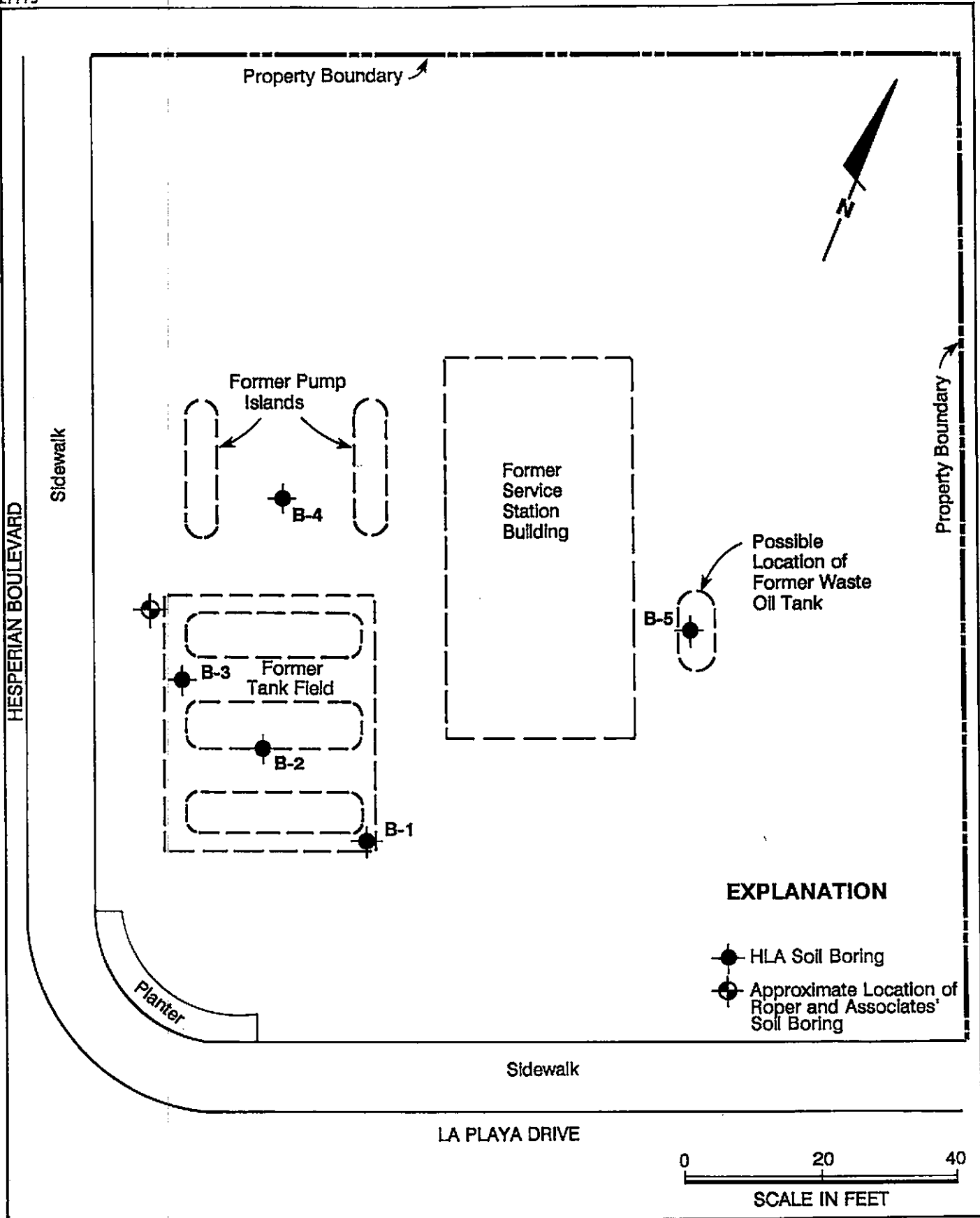

Harding Lawson Associates
 Engineering and
 Environmental Services

Site Map / Soil Boring Locations
 Equity Properties
 24688 Hesperian Boulevard
 Hayward, California

PLATE

2

DRAWN
DC

JOB NUMBER
20354 1

APPROVED
MJH

DATE
7/92

REVISED

DATE

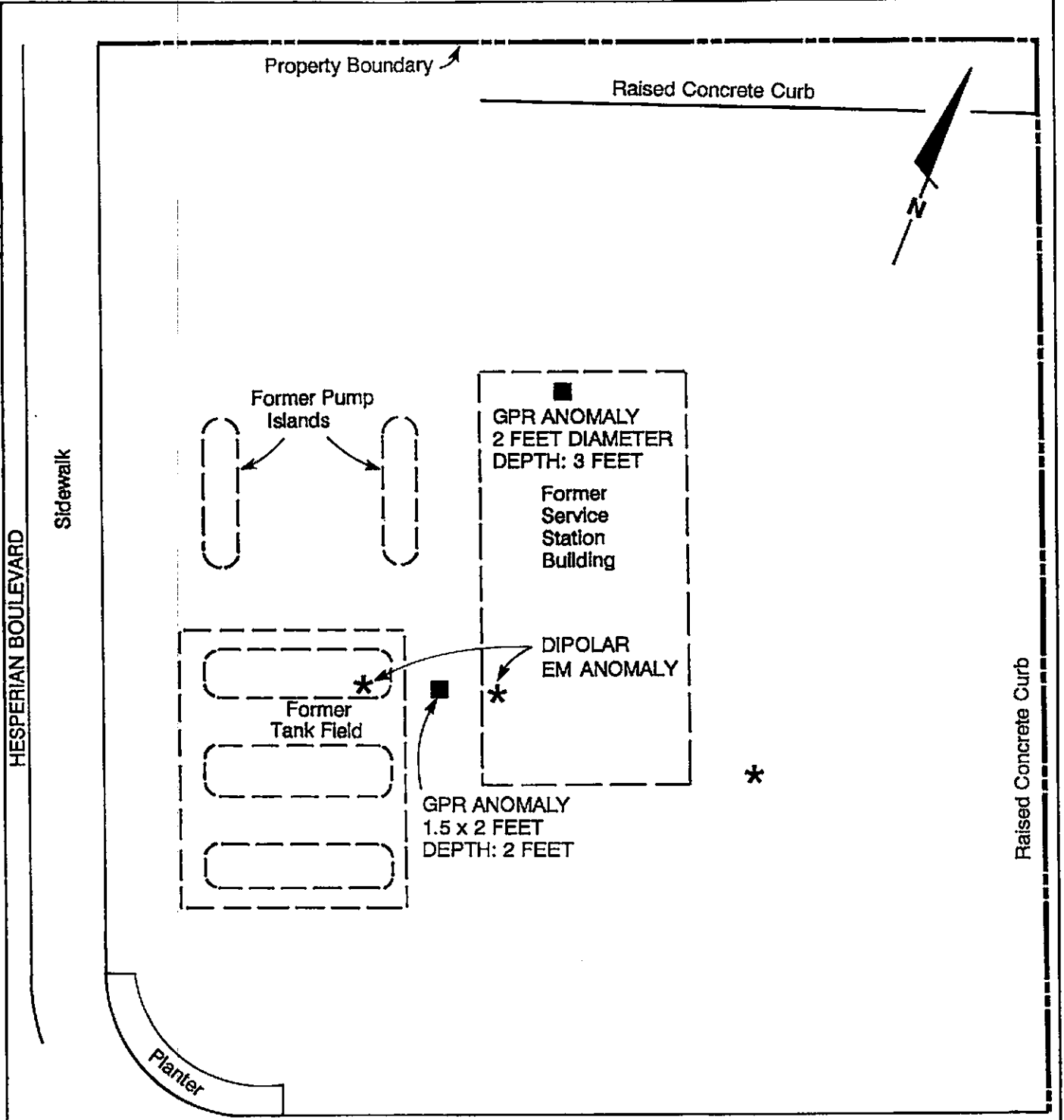

EXPLANATION

- Ground penetrating radar (GPR) anomaly
- * Electromagnetic (EM) Anomaly

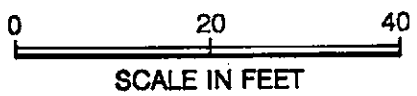

Harding Lawson Associates
Engineering and
Environmental Services

**Ground Penetrating Radar (GPR) and
Electromagnetic (EM) Anomalies**
Equity Properties
24688 Hesperian Boulevard
Hayward, California

PLATE
3

DRAWN DC	JOB NUMBER 20354 1	APPROVED MJH	DATE 7/92	REVISED	DATE
-------------	-----------------------	-----------------	--------------	---------	------

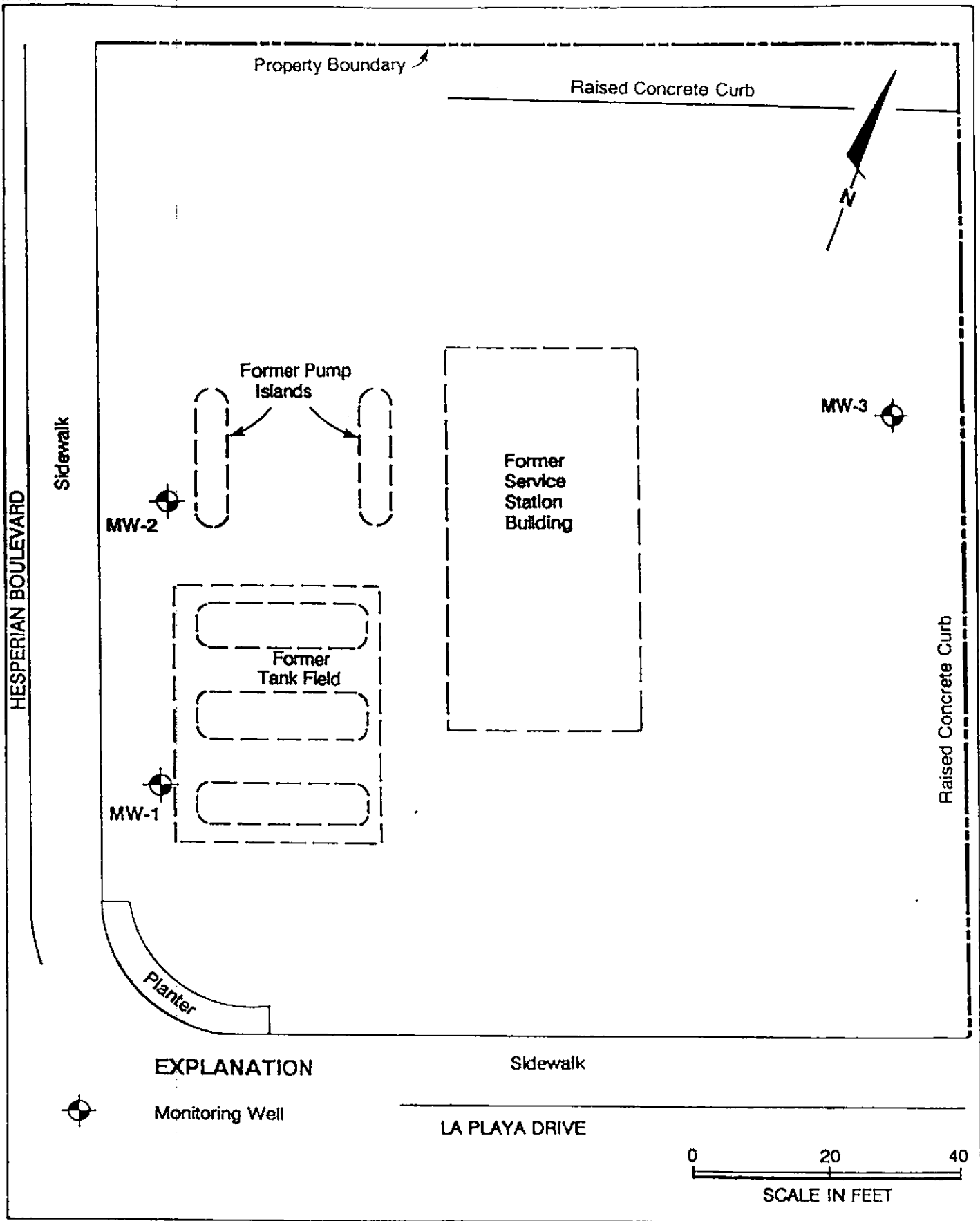

EXPLANATION



Monitoring Well

Sidewalk

LA PLAYA DRIVE

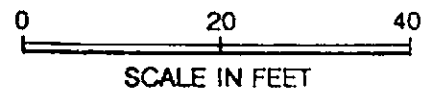

Harding Lawson Associates
Engineering and
Environmental Services

Monitoring Well Locations
Equity Properties
24688 Hesperian Boulevard
Hayward, California

4

DRAWN
DC

JOB NUMBER
20354 1

APPROVED
MJH



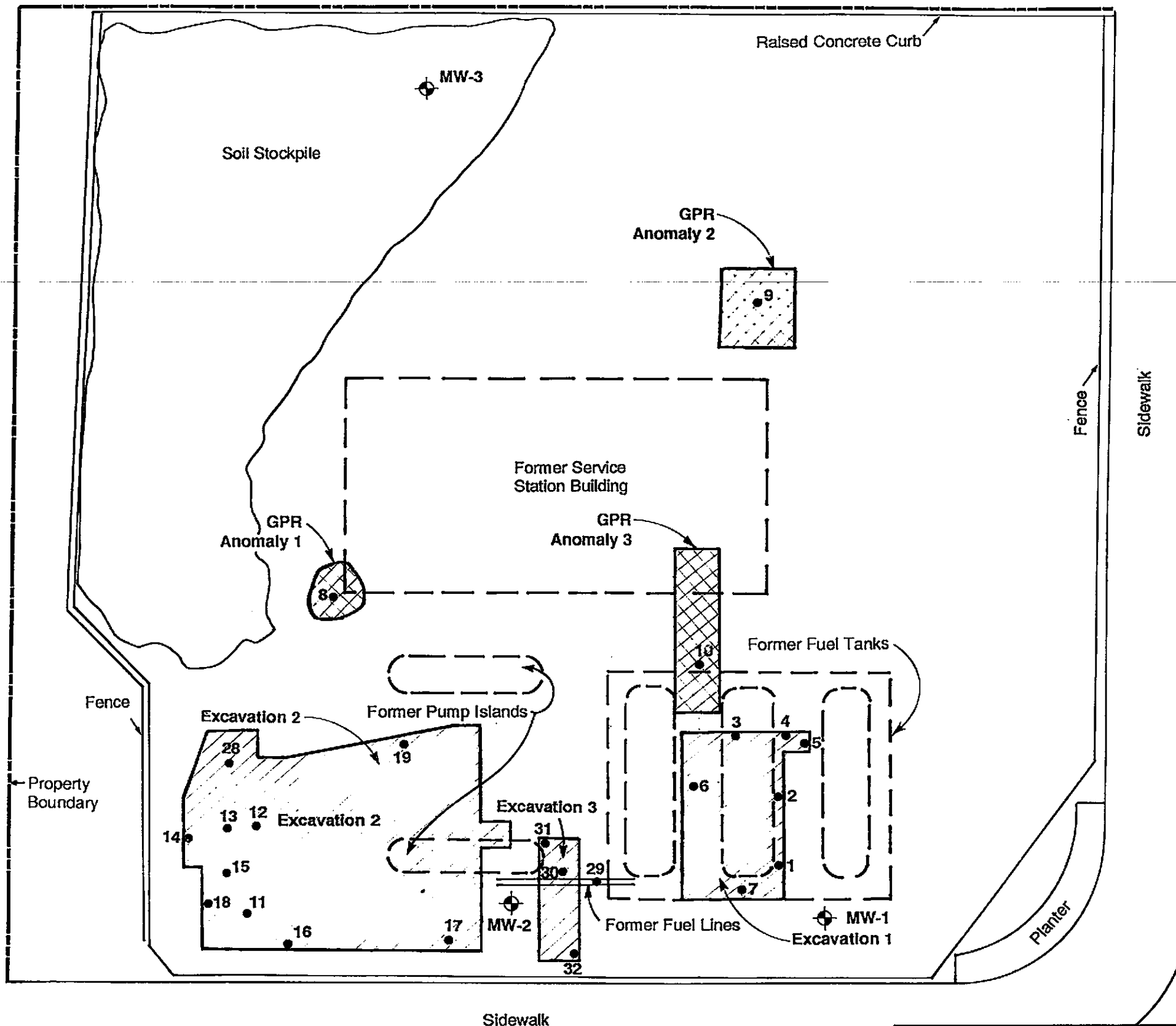

DATE
7/92

REVISED

DATE



EXPLANATION

-  Monitoring Well
-  Shallow Excavation
-  Deep Excavation
-  Sample Location and Number



N



0 8 16
SCALE IN FEET

HESPERIAN BOULEVARD



Harding Lawson Associates
Engineering and Environmental Services



Excavation and Confirmation Sample Locations
Equity Properties
24688 Hesperian Boulevard
Hayward, California

PLATE

5

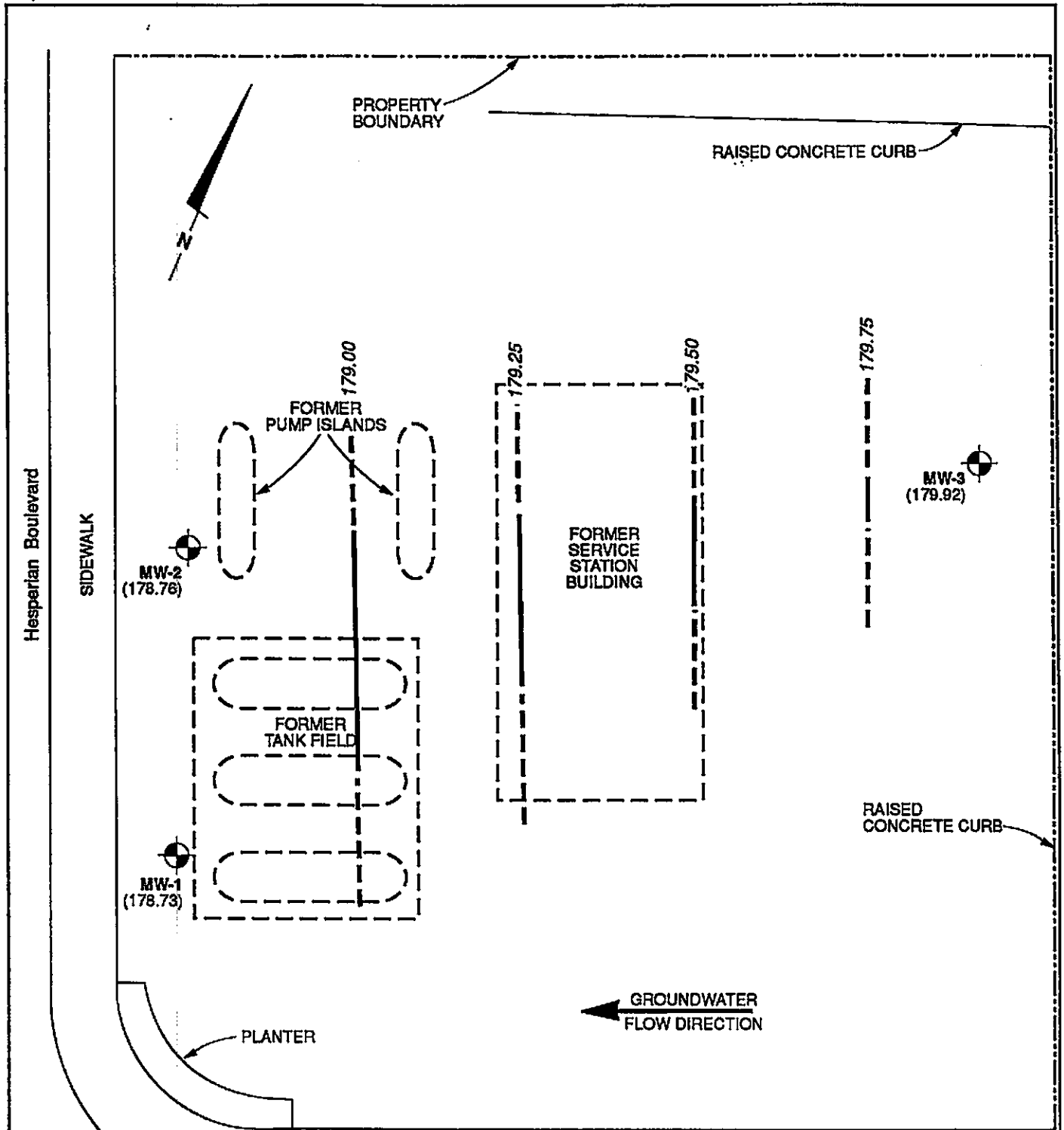
DRAWN NJB	JOB NUMBER 20354 1	APPROVED MJH	DATE 7/92	REVISED DATE
--------------	-----------------------	-----------------	--------------	--------------



EXPLANATION	
MW-1 (178.73) 	Monitoring Well and Potentiometric Elevation (in feet MSL)
 179.50	Potentiometric Elevation Contour, dashed where inferred

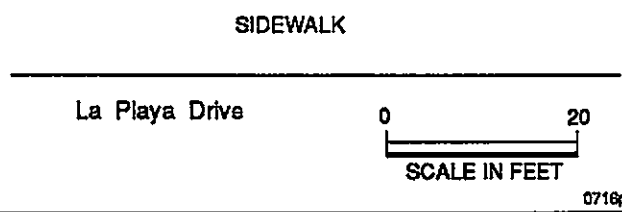

Harding Lawson Associates
 Engineering and Environmental Services

Potentiometric Surface Contours - 7/22/91
 Equity Properties
 24688 Hesperian Boulevard
 Hayward, California

PLATE
6

DRAWN	JOB NUMBER	APPROVED	DATE	REVISED DATE
CSNc	20354 1	<i>MSH</i>	7/92	

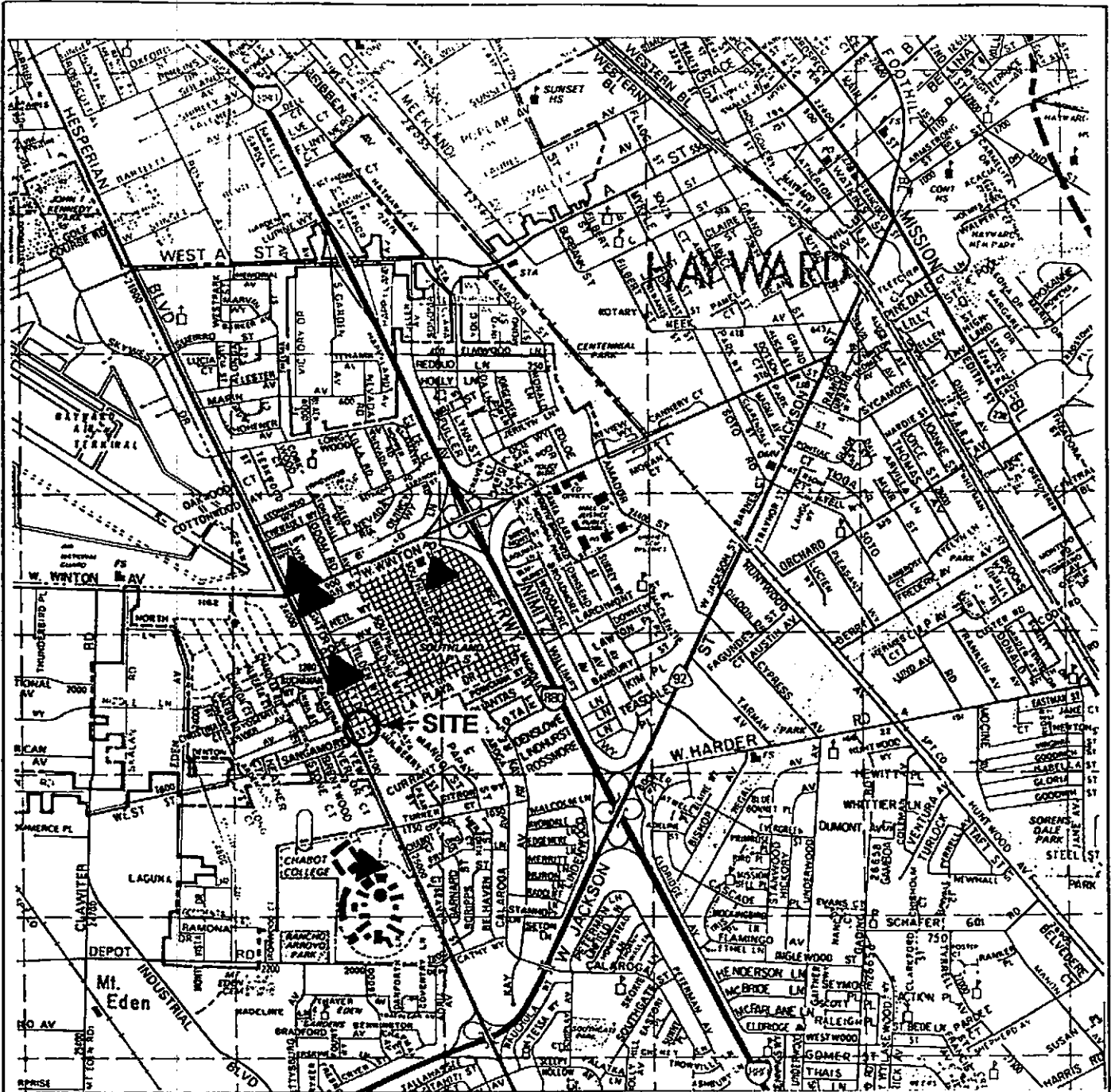

EXPLANATION

▲ Approximate Location of Fuel Leak Site



Harding Lawson Associates
Engineering and
Environmental Services

Fuel Leak Sites
Equity Properties
24688 Hesperian Boulevard
Hayward, California

PI ALL

7

DRAWN
DC

JOB NUMBER
20354 1

APPROVED
MJH

DATE
7/92

REVISED

DATE