



RECEIVED

10:50 am, Sep 19, 2011
Alameda County
Environmental Health

Dave Patten
Project Manager
Marketing Business Unit

**Chevron Environmental
Management Company**
6111 Bollinger Canyon Road
San Ramon, CA 94583
Tel (925) 543-1740
Fax (925) 543-2324
drpatten@chevron.com

Alameda County Health Care Services
1131 Harbor Bay Parkway, Suite 250
Alameda, CA 94502-6577

Re: Chevron Service Station No. 9-1851
451 Hegenberger Drive
Oakland, CA

I have reviewed the attached report dated September 16, 2011.

I agree with the conclusions and recommendations presented in the referenced report. The information in this report is accurate to the best of my knowledge and all local Agency/Regional Board guidelines have been followed. This report was prepared by Conestoga-Rovers & Associates, upon whose assistance and advice I have relied.

This letter is submitted pursuant to the requirements of California Water Code Section 13267(b)(1) and the regulating implementation entitled Appendix A pertaining thereto.

I declare under penalty of perjury that the foregoing is true and correct to the best of my knowledge.

Sincerely,

Dave Patten
on behalf of

Dave Patten
Project Manager

Attachment: Report



**CONESTOGA-ROVERS
& ASSOCIATES**

5900 Hollis Street, Suite A
Emeryville, California 94608
Telephone: (510) 420-0700 Fax: (510) 420-9170
<http://www.craworld.com>

September 16, 2011

Reference No. 311976

Mr. Mark Detterman
Alameda County Environmental Health Services
1131 Harbor Bay Parkway, Suite 250
Alameda, California 94502-6577

Dear Mr. Detterman:

Re: Modified Work Plan Addendum
Former Chevron Service Station 9-1851
451 Hegenberger Road
Oakland, California
Fuel Leak Case No. RO0000464

On behalf of Chevron Environmental Management Company (Chevron) Conestoga-Rovers & Associates (CRA) has prepared this *Modified Work Plan Addendum* letter in response to Alameda County Environmental Health Services' (ACEH) letter dated August 15, 2011 (enclosed).

As requested, CRA proposes to advance two additional soil borings, one boring in the former used-oil underground storage tank (UST) location and one boring south of the dispensers (Figure 1). The boring locations are dependent on the location of utilities, USTs and product lines. These soil borings shall be advanced with methods described in CRA's *Work Plan for Soil Borings* dated June 30, 2009 and CRA's *Work Plan for Soil Borings Addendum* dated June 29, 2011.

CRA will proceed with the proposed scope of work upon receipt of written approval from ACEH. After approval, CRA will obtain the necessary drilling permits, access agreements, and schedule the subcontractors at their earliest availability. We will submit our investigation report approximately eight weeks after completion of field activities and receipt of analytical results.

Equal
Employment Opportunity
Employer



**CONESTOGA-ROVERS
& ASSOCIATES**

September 16, 2011

Reference No. 311976

- 2 -

We appreciate the opportunity to work with you on this project. Please contact Mr. Nathan Lee at (510) 420-3333 or Mr. Dave Patten, of Chevron, at (925) 790-6491 if you have any questions or comments regarding this report.

Regards,

CONESTOGA-ROVERS & ASSOCIATES

Nathan Lee, PG 8486



NL/cm/11-Addendum

Encl.

Figure 1 Proposed Boring Locations
Attachment Regulatory Correspondence

cc: Mr. Dave Patten, Chevron Environmental Management Company
 SimGas, LLC

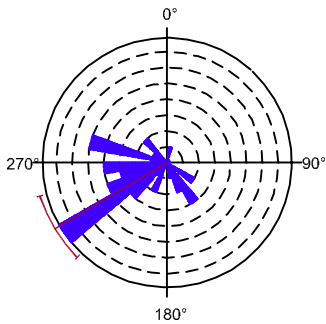

HISTORICAL GROUNDWATER FLOW DIRECTION
1995 - 1Q 2011

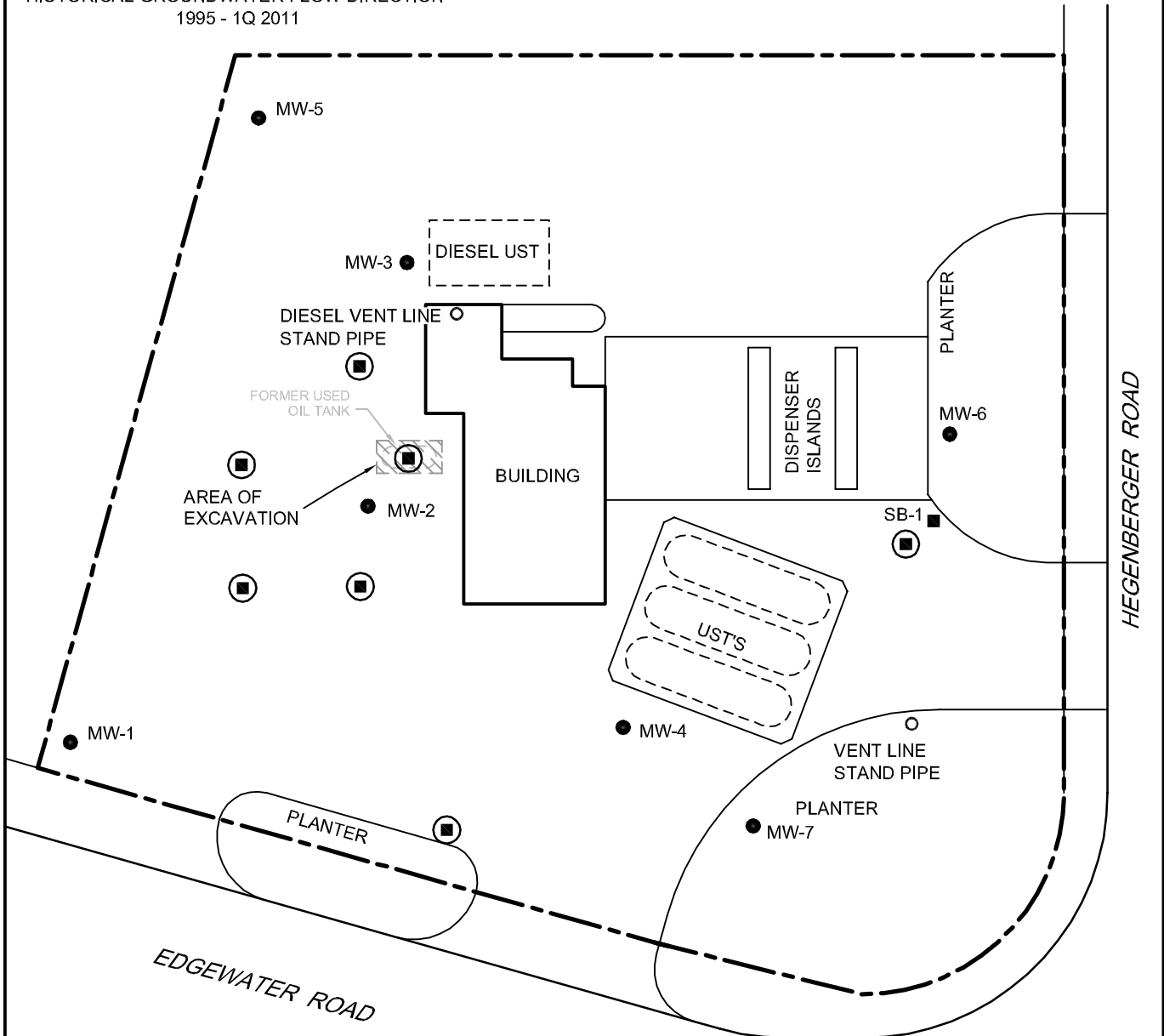
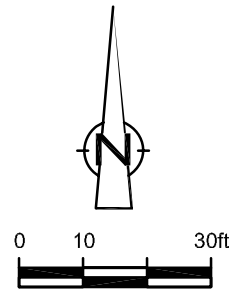

- LEGEND**
- MW-1 ● MONITORING WELL LOCATION
 - SB-1 ■ SOIL BORING LOCATION
 - ◻ PROPOSED SOIL BORING LOCATION

Figure 1
PROPOSED BORING LOCATIONS
CHEVRON SERVICE STATION 9-1851
451 HEGENBERGER ROAD
Oakland, California





ENVIRONMENTAL HEALTH SERVICES
ENVIRONMENTAL PROTECTION
1131 Harbor Bay Parkway, Suite 250
Alameda, CA 94502-6577
(510) 567-6700
FAX (510) 337-9335

August 15, 2011

Mr. David Patton
Chevron Corporation
6111 Bollinger Canyon Road
San Ramon, CA 94583
(sent via electronic mail to
drpatten@chevron.com)

Mr. Mark Gomez
City of Oakland
250 Frank Ogawa Plaza,
Suite 5301
Oakland, CA, 9461

Simgas LLC
655 Montgomery St #1900
San Francisco, CA 94111

Gurinder Grewal & Singh Navdeep
349 Brianne Ct.
Pleasanton, CA 94566

Subject: Modified Work Plan Addendum Approval; Fuel Leak Case No. RO0000464; (Global ID # T0600102238); Chevron #9-1851, 451 Hegenberger Road, Oakland, CA 94612

Dear Ladies and Gentlemen:

Alameda County Environmental Health Department (ACEH) staff has reviewed the case file, including the *First Quarter 2011 Groundwater Monitoring and Sampling Report*, dated May 23, 2011 and the *Work Plan for Soil Borings Addendum*, dated July 1, 2011. These reports were prepared and submitted on your behalf by Conestoga-Rovers & Associates (CRA). Thank you for submitting the reports. The addendum proposes the installation of five soil bores, four around the former waste oil UST location to define the lateral extent of free-phase waste oil, and one downgradient of well MW-4 to further delineate the gasoline dissolved-phase hydrocarbon plume in the downgradient direction. The previous work plan from January 30, 2009 was withdrawn due to non-detectable concentrations of TPHg and BTEX in groundwater since September 2009, (with relatively low concentrations of MTBE in well MW-4).

ACEH is in general agreement with the work plan addendum; however, an existing investigation request by ACEH has not been satisfied; thus ACEH requests a work plan addendum to clarify the proposed work prior to implementation. Consequently, we request that you address the following technical comments, send the requested document, perform the proposed work, and send us the technical reports requested below. Please provide 72-hour advance written notification to this office (e-mail preferred to: mark.detterman@acgov.org) prior to the start of field activities.

TECHNICAL COMMENTS

- 1. Existing Request for Vertical Delineation** – The September 30, 2009 directive letter requested source area vertical delineation of soil (waste oil UST and eastern fuel dispenser) which has not been satisfied. Please ensure that soil contamination is defined vertically in both source areas with the installation of a minimum of one soil bore in each source area. Please additionally ensure soil contamination is defined vertically downgradient of each source area. This would appear to require the installation of an additional two soil bores at a maximum, one in each source area. Please additionally investigate for the potential of, and the stabilized thickness of, free-phase waste oil in the backfilled waste oil UST excavation to help clarify future actions. By the date identified below, please submit a work plan addendum (revised soil bore location map). Please also additionally submit a subsurface investigation report by the following date.

TECHNICAL REPORT REQUEST

Please submit technical reports to Alameda County Environmental Health (Attention: Mr. Mark Detterman), according to the following schedule:

- **September 16, 2011** – Work Plan Addendum (revised soil bore map)
- **October 28, 2011** - Subsurface Investigation Report
- **December 2, 2011** – Third Quarter Semi-Annual Groundwater Monitoring Report
- **May 25, 2012** – First Quarter Semi-Annual Groundwater Monitoring Report

These reports are being requested pursuant to California Health and Safety Code Section 25296.10. 23 CCR Sections 2652 through 2654, and 2721 through 2728 outline the responsibilities of a responsible party in response to an unauthorized release from a petroleum UST system, and require your compliance with this request.

Should you have any questions, please contact me at (510) 567-6876 or send me an electronic mail message at mark.detterman@acgov.org.

Sincerely,



Digitally signed by Mark E. Detterman
DN: cn=Mark E. Detterman, o, ou,
email, c=US
Date: 2011.08.15 11:58:45 -07'00'

Mark E. Detterman, PG, CEG
Senior Hazardous Materials Specialist

Enclosures: Attachment 1 – Responsible Party (ies) Legal Requirements / Obligations
Electronic Report Upload (ftp) Instructions

cc: Nathan Lee, Conestoga-Rovers & Assoc., 5900 Hollis Street, Suite A, Emeryville, CA 94608
(sent via electronic mail to NLee@craworld.com)

Donna Drogos (sent via electronic mail to donna.drogos@acgov.org)
Mark Detterman (sent via electronic mail to mark.detterman@acgov.org)
Electronic File, GeoTracker

Attachment 1

Responsible Party(ies) Legal Requirements / Obligations

REPORT REQUESTS

These reports are being requested pursuant to California Health and Safety Code Section 25296.10. 23 CCR Sections 2652 through 2654, and 2721 through 2728 outline the responsibilities of a responsible party in response to an unauthorized release from a petroleum UST system, and require your compliance with this request.

ELECTRONIC SUBMITTAL OF REPORTS

ACEH's Environmental Cleanup Oversight Programs (LOP and SLIC) require submission of reports in electronic form. The electronic copy replaces paper copies and is expected to be used for all public information requests, regulatory review, and compliance/enforcement activities. Instructions for submission of electronic documents to the Alameda County Environmental Cleanup Oversight Program FTP site are provided on the attached "Electronic Report Upload Instructions." Submission of reports to the Alameda County FTP site is an addition to existing requirements for electronic submittal of information to the State Water Resources Control Board (SWRCB) GeoTracker website. In September 2004, the SWRCB adopted regulations that require electronic submittal of information for all groundwater cleanup programs. For several years, responsible parties for cleanup of leaks from underground storage tanks (USTs) have been required to submit groundwater analytical data, surveyed locations of monitoring wells, and other data to the GeoTracker database over the Internet. Beginning July 1, 2005, these same reporting requirements were added to Spills, Leaks, Investigations, and Cleanup (SLIC) sites. Beginning July 1, 2005, electronic submittal of a complete copy of all reports for all sites is required in GeoTracker (in PDF format). Please visit the SWRCB website for more information on these requirements (http://www.waterboards.ca.gov/water_issues/programs/ust/electronic_submittal/).

PERJURY STATEMENT

All work plans, technical reports, or technical documents submitted to ACEH must be accompanied by a cover letter from the responsible party that states, at a minimum, the following: "I declare, under penalty of perjury, that the information and/or recommendations contained in the attached document or report is true and correct to the best of my knowledge." This letter must be signed by an officer or legally authorized representative of your company. Please include a cover letter satisfying these requirements with all future reports and technical documents submitted for this fuel leak case.

PROFESSIONAL CERTIFICATION & CONCLUSIONS/RECOMMENDATIONS

The California Business and Professions Code (Sections 6735, 6835, and 7835.1) requires that work plans and technical or implementation reports containing geologic or engineering evaluations and/or judgments be performed under the direction of an appropriately registered or certified professional. For your submittal to be considered a valid technical report, you are to present site specific data, data interpretations, and recommendations prepared by an appropriately licensed professional and include the professional registration stamp, signature, and statement of professional certification. Please ensure all that all technical reports submitted for this fuel leak case meet this requirement.

UNDERGROUND STORAGE TANK CLEANUP FUND

Please note that delays in investigation, later reports, or enforcement actions may result in your becoming ineligible to receive grant money from the state's Underground Storage Tank Cleanup Fund (Senate Bill 2004) to reimburse you for the cost of cleanup.

AGENCY OVERSIGHT

If it appears as though significant delays are occurring or reports are not submitted as requested, we will consider referring your case to the Regional Board or other appropriate agency, including the County District Attorney, for possible enforcement actions. California Health and Safety Code, Section 25299.76 authorizes enforcement including administrative action or monetary penalties of up to \$10,000 per day for each day of violation.

Alameda County Environmental Cleanup Oversight Programs (LOP and SLIC)	REVISION DATE: July 20, 2010
	ISSUE DATE: July 5, 2005
	PREVIOUS REVISIONS: October 31, 2005; December 16, 2005; March 27, 2009; July 8, 2010
SECTION: Miscellaneous Administrative Topics & Procedures	SUBJECT: Electronic Report Upload (ftp) Instructions

The Alameda County Environmental Cleanup Oversight Programs (LOP and SLIC) require submission of all reports in electronic form to the county's ftp site. Paper copies of reports will no longer be accepted. The electronic copy replaces the paper copy and will be used for all public information requests, regulatory review, and compliance/enforcement activities.

REQUIREMENTS

- **Please do not submit reports as attachments to electronic mail.**
- Entire report including cover letter must be submitted to the ftp site as a **single portable document format (PDF) with no password protection.**
- It is **preferable** that reports be converted to PDF format from their original format, (e.g., Microsoft Word) rather than scanned.
- **Signature pages and perjury statements must be included and have either original or electronic signature.**
- **Do not password protect the document.** Once indexed and inserted into the correct electronic case file, the document will be secured in compliance with the County's current security standards and a password. **Documents with password protection will not be accepted.**
- Each page in the PDF document should be rotated in the direction that will make it easiest to read on a computer monitor.
- Reports must be named and saved using the following naming convention:

RO#_Report Name_Year-Month-Date (e.g., RO#5555_WorkPlan_2005-06-14)

Submission Instructions

- 1) Obtain User Name and Password
 - a) Contact the Alameda County Environmental Health Department to obtain a User Name and Password to upload files to the ftp site.
 - i) Send an e-mail to deh.loptoxic@acgov.org
 - b) In the subject line of your request, be sure to include **"ftp PASSWORD REQUEST"** and in the body of your request, include the **Contact Information, Site Addresses, and the Case Numbers (RO# available in Geotracker) you will be posting for.**
- 2) Upload Files to the ftp Site
 - a) Using Internet Explorer (IE4+), go to <ftp://alcoftp1.acgov.org>
 - (i) Note: Netscape, Safari, and Firefox browsers will not open the FTP site as they are NOT being supported at this time.
 - b) Click on Page located on the Command bar on upper right side of window, and then scroll down to Open FTP Site in Windows Explorer.
 - c) Enter your User Name and Password. (Note: Both are Case Sensitive.)
 - d) Open "My Computer" on your computer and navigate to the file(s) you wish to upload to the ftp site.
 - e) With both "My Computer" and the ftp site open in separate windows, drag and drop the file(s) from "My Computer" to the ftp window.
- 3) Send E-mail Notifications to the Environmental Cleanup Oversight Programs
 - a) Send email to deh.loptoxic@acgov.org notify us that you have placed a report on our ftp site.
 - b) Copy your Caseworker on the e-mail. Your Caseworker's e-mail address is the entire first name then a period and entire last name @acgov.org. (e.g., firstname.lastname@acgov.org)
 - c) The subject line of the e-mail must start with the RO# followed by **Report Upload.** (e.g., Subject: RO1234 Report Upload) If site is a new case without an RO#, use the street address instead.
 - d) If your document meets the above requirements and you follow the submission instructions, you will receive a notification by email indicating that your document was successfully uploaded to the ftp site.