

MONITORING  
PURGING  
DISPOSING  
SAMPLING

**MPDS**

SERVICES, INCORPORATED

ENVIRONMENTAL

95 AUG 25 PM 2:46

0.2

is ORO being used?

August 24, 1995

Alameda County Health Care Services  
1131 Harbor Bay Parkway  
Alameda, California 94501

RE: Unocal Service Station #6034  
4700 First Street  
Livermore, California

Per the request of the Unocal Corporation Project Manager, Ms. Tina R. Berry, enclosed please find our report (MPDS-UN6034-07) dated August 14, 1995 for the above referenced site.

Should you have any questions regarding the reporting of data, please feel free to call our office at (510) 602-5120. Any other questions may be directed to the Project Manager at (510) 277-2321.

Sincerely,

MPDS Services, Inc.

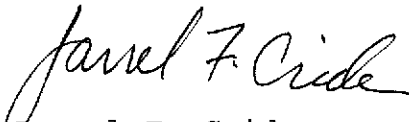

Jarrel F. Crider

/jfc

Enclosure

cc: Ms. Tina R. Berry

MPDS-UN6034-07  
August 11, 1995

Unocal Corporation  
2000 Crow Canyon Place, Suite 400  
P.O. Box 5155  
San Ramon, California 94583

Attention: Ms. Tina R. Berry

RE: Quarterly Data Report  
Unocal Service Station #6034  
4700 First Street  
Livermore, California

Dear Ms. Berry:

This data report presents the results of the most recent quarter of monitoring and sampling of the monitoring wells at the referenced site by MPDS Services, Inc.

#### RECENT FIELD ACTIVITIES

The Unocal monitoring wells that were monitored and sampled during this quarter are indicated in Table 1. Prior to sampling, the Unocal wells were checked for depth to water and the presence of free product or sheen. The monitoring data and the ground water elevations for the Unocal wells are summarized in Table 1. The ground water flow direction at the Unocal site during the most recent quarter is shown on the attached Figure 1.

A joint monitoring and sampling event was conducted with the consultant for the nearby Chevron site on July 18, 1995. The monitoring data collected for the Chevron monitoring wells (provided by Blaine Tech Services, Inc.) are summarized in Table 2. The ground water flow direction at the Chevron site during the most recent quarter is also shown on the attached Figure 1.

Ground water samples were collected from the Unocal wells on July 18, 1995. Prior to sampling, the wells were each purged of between 6.5 and 8.5 gallons of water. Samples were then collected using a clean Teflon bailer. The samples were decanted into clean VOA vials and/or one-liter amber bottles, as appropriate, which were then sealed with Teflon-lined screw caps, labeled, and stored in a cooler, on ice, until delivery to a state-certified laboratory. MPDS Services, Inc. transported the purged ground water to the Unocal Refinery located in Rodeo, California, for treatment and discharge to San Pablo Bay under NPDES permit.

#### ANALYTICAL RESULTS

The ground water samples collected from the Unocal wells were analyzed at Sequoia Analytical Laboratory and were accompanied by properly

executed Chain of Custody documentation. The analytical results of the ground water samples collected from the Unocal wells to date are summarized in Tables 3 and 4. The concentrations of Total Petroleum Hydrocarbons (TPH) as gasoline and benzene detected in the ground water samples collected from the Unocal wells this quarter are shown on the attached Figure 2. Copies of the laboratory analytical results and the Chain of Custody documentation for the Unocal wells are attached to this report.

LIMITATIONS

Environmental changes, either naturally-occurring or artificially-induced, may cause changes in ground water levels and flow paths, thereby changing the extent and concentration of any contaminants.

DISTRIBUTION

A copy of this report should be sent to the Alameda County Health Care Services Agency.

If you have any questions regarding this report, please do not hesitate to call Mr. Nubar Srabian at (510) 602-5120.

Sincerely,

MPDS Services, Inc.

  
Sarkis A. Karkarian  
Staff Engineer

  
Joel G. Greger, C.E.G.  
Senior Engineering Geologist

License No. EG 1633  
Exp. Date 8/31/96

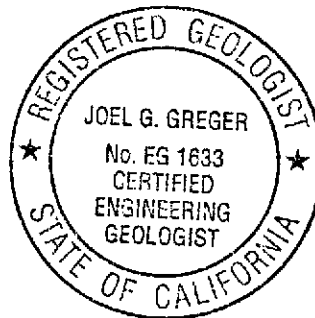

/bp

Attachments: Tables 1 through 4  
Location Map  
Figures 1 & 2  
Laboratory Analyses  
Chain of Custody documentation

cc: Mr. Thomas J. Berkins, Kaprealian Engineering, Inc.

**TABLE 1**

**SUMMARY OF MONITORING DATA  
 UNOCAL MONITORING WELLS**

Well #	Ground Water Elevation (feet)	Depth to Water (feet)◆	Total Well Depth (feet)◆	Product Thickness (feet)	Sheen	Water Purged (gallons)	
<b>(Monitored and Sampled on July 18, 1995)</b>							
MW1*	505.86	14.78	27.91	0	--	0	
MW2▲	505.71	14.11	25.64	0	No	8	
MW3*	506.47	13.19	25.43	0	--	0	
MW4	506.40	13.21	25.50	0	No	8.5	
MW5	505.86	14.41	23.60	0	No	6.5	
MW6	504.91	13.84	23.17	0	No	6.5	
MW7	505.47	13.36	23.65	0	No	7	
<b>(Monitored and Sampled on April 17, 1995)</b>							
MW1	505.82	14.82	27.90	0	No	9	
MW2	505.69	14.13	25.62	0	No	8	
MW3	506.46	13.20	25.42	0	No	8.5	
MW4	506.42	13.19	25.47	0	No	8.5	
MW5	505.77	14.50	23.58	0	No	6.5	
MW6	504.93	13.82	23.15	0	No	6.5	
MW7	505.45	13.38	23.65	0	No	7	
<b>(Monitored and Sampled on January 18, 1995)</b>							
MW1*	506.08	14.56	27.93	0	--	0	
MW2	505.72	14.10	25.63	0	No	8	
MW3*	506.43	13.23	25.40	0	--	0	
MW4	506.45	13.16	25.46	0	No	8.5	
MW5	505.75	14.52	23.56	0	No	6.5	
MW6	WELL WAS OBSTRUCTED BY ROOTS						
MW7	505.49	13.34	23.63	0	No	7	
<b>(Monitored and Sampled on October 19, 1994)</b>							
MW1*	505.36	15.28	27.92	0	--	0	
MW2	505.02	14.80	25.65	0	No	7.5	
MW3	505.58	14.08	25.42	0	No	8	
MW4	505.66	13.95	25.47	0	No	8	
MW5	505.07	15.20	23.57	0	No	6	
MW6	WELL WAS OBSTRUCTED BY ROOTS						
MW7	504.78	14.05	23.65	0	No	7	

TABLE 1 (Continued)

SUMMARY OF MONITORING DATA  
UNOCAL MONITORING WELLS

<u>Well #</u>	<u>Well Casing Elevation (feet)**</u>
MW1	520.64
MW2	519.82
MW3	519.66
MW4	519.61
MW5	520.27
MW6	518.75
MW7	518.83

- ◆ The depth to water level and total well depth measurements were taken from the top of the well casings.
- \* Monitored only.
- \*\* The elevations of the top of the well casings are relative to Mean Sea Level (MSL), per the City of Livermore Benchmark No. C-18-5 (elevation = 551.77 feet MSL).
- ▲ Dissolved oxygen reading = 4.22 ppm.
- Sheen determination was not performed.

**TABLE 2**

SUMMARY OF MONITORING DATA  
CHEVRON MONITORING WELLS

(Provided by Blaine Tech Services, Inc.)

<u>Well #</u>	<u>Ground Water Elevation (feet)</u>	<u>Depth to Water (feet)</u>	<u>Well Casing Elevation (feet)*</u>
(Monitored on July 18, 1995)			
C-1	508.27	12.12	520.39
C-2	508.34	12.42	520.76
C-3	508.42	12.89	521.31
C-5	508.51	12.31	520.82
C-6	508.16	11.46	519.62
C-7	508.32	11.98	520.30
C-8	WELL WAS DRY		519.74
C-9	508.06	11.66	519.72
C-10	506.97	13.44	520.41
C-11	507.04	13.00	520.04
C-12	506.70	13.12	519.82
C-13	508.91	13.33	522.24
C-14	WELL WAS DRY		520.08
C-15	508.61	13.80	522.41
C-16	WELL WAS INACCESSIBLE		519.68
C-17	507.38	13.44	520.82
C-19	505.24	13.72	518.96

\* Relative to Mean Sea Level.

**TABLE 3**

SUMMARY OF LABORATORY ANALYSES  
 WATER  
 UNOCAL MONITORING WELLS

Date	Well #	TPH as Gasoline	Benzene	Toluene	Ethyl-benzene	Xylenes
11/18/89	MW1	ND	ND	ND	ND	ND
3/08/90	MW1	ND	ND	ND	ND	ND
6/05/90	MW1	ND	ND	ND	ND	ND
9/07/90	MW1	ND	ND	1.2	ND	ND
12/24/90	MW1	ND	ND	ND	ND	0.40
4/10/91	MW1	ND	ND	ND	ND	ND
7/10/91	MW1	ND	ND	ND	ND	ND
4/21/94	MW1	ND	ND	ND	ND	ND
7/21/94	MW1	SAMPLED ANNUALLY				
10/19/94	MW1	SAMPLED ANNUALLY				
1/18/95	MW1	SAMPLED ANNUALLY				
4/17/95	MW1*	ND	ND	ND	ND	ND
7/18/95	MW1	SAMPLED ANNUALLY				
11/18/89	MW2	53,000	540	500	130	22,000
3/08/90	MW2	26,000	230	410	1,300	2,100
6/05/90	MW2	31,000	250	460	950	9,200
9/07/90	MW2	ND	ND	1.5	ND	ND
12/24/90	MW2	32,000	440	340	460	13,000
4/10/91	MW2	22,000	170	190	490	6,200
7/10/91	MW2	14,000	70	160	570	5,400
10/14/91	MW2	11,000	79	130	660	4,700
1/14/92	MW2	5,600	36	120	450	2,600
4/06/92	MW2	760	6.3	2.1	ND	130
7/07/92	MW2	44,000	160	1,100	1,000	17,000
10/16/92	MW2	290	2.3	ND	5.1	15
1/14/93	MW2	19,000	75	430	900	8,400
4/22/93	MW2	49,000	150	1,000	3,000	18,000
7/20/93	MW2	25,000	68	94	1,000	6,200
10/20/93	MW2	12,000	27	10	100	3,000
1/20/94	MW2	20,000	ND	ND	270	3,300
4/21/94	MW2	27,000	85	65	880	5,300
7/21/94	MW2	31,000	58	29	940	6,200
10/19/94	MW2	4,100	16	3.5	8.6	1,100
1/18/95	MW2	5,100	6.8	7.3	100	1,500
4/17/95	MW2	320	1.3	0.67	6.6	74
7/18/95	MW2	12,000	25	24	550	3,700

**TABLE 3 (Continued)**

SUMMARY OF LABORATORY ANALYSES  
 WATER  
 UNOCAL MONITORING WELLS

Date	Well #	TPH as Gasoline	Benzene	Toluene	Ethyl-benzene	Xylenes
11/18/89	MW3	ND	0.35	ND	ND	ND
3/08/90	MW3	ND	ND	ND	ND	ND
6/05/90	MW3	ND	ND	ND	ND	ND
9/07/90	MW3	1,100	11	ND	6.6	16
12/24/90	MW3	ND	ND	ND	ND	ND
4/10/91	MW3	ND	ND	ND	ND	ND
7/10/91	MW3	ND	ND	ND	ND	ND
10/14/91	MW3	ND	ND	ND	ND	ND
1/14/92	MW3	ND	ND	ND	ND	ND
4/06/92	MW3	ND	ND	ND	ND	ND
7/07/92	MW3	ND	ND	ND	ND	ND
10/16/92	MW3	ND	ND	ND	ND	ND
1/14/93	MW3	ND	ND	ND	ND	ND
4/22/93	MW3	ND	ND	ND	ND	ND
7/20/93	MW3	ND	ND	ND	ND	ND
10/20/93	MW3	ND	ND	ND	ND	ND
1/20/94	MW3	SAMPLED SEMI-ANNUALLY				
4/21/94	MW3	ND	ND	ND	ND	ND
7/21/94	MW3	SAMPLED SEMI-ANNUALLY				
10/19/94	MW3	ND	ND	0.61	ND	0.51
1/18/95	MW3	SAMPLED SEMI-ANNUALLY				
4/17/95	MW3	ND	ND	ND	ND	ND
7/18/95	MW3	SAMPLED SEMI-ANNUALLY				
11/18/89	MW4	990	9.8	10	7.1	4.7
3/08/90	MW4	1,200	18	8.4	37	28
6/05/90	MW4	1,400	1.2	4.7	24	12
9/07/90	MW4	15,000	100	140	210	4,600
12/24/90	MW4	1,400	ND	8.7	15	10
4/10/91	MW4	950	0.84	4.3	9.6	5.0
7/10/91	MW4	830	8.4	19	7.7	7.2
10/14/91	MW4	880	3.8	2.2	8.6	5.8
1/14/92	MW4	1,500	4.2	7.1	18	9.2
4/06/92	MW4	660	1.3	3.8	2.9	4.1
7/07/92	MW4	340	ND	2.2	2.4	2.4
10/16/92	MW4	300	2.1	ND	4.8	13
1/14/93	MW4	920	ND	6.3	12	3.9
4/22/93	MW4	1,100	8.8	1.0	7.2	6.0



**TABLE 3 (Continued)**

SUMMARY OF LABORATORY ANALYSES  
 WATER  
 UNOCAL MONITORING WELLS

Date	Well #	TPH as Gasoline	Benzene	Toluene	Ethyl-benzene	Xylenes
7/20/93	MW4	NOT SAMPLED - SAMPLING ACCESS DENIED				
10/20/93	MW4	640	ND	2.5	2.3	1.9
1/20/94	MW4	1,200	ND	2.6	4.7	7.4
4/21/94	MW4	380	0.83	1.2	1.2	1.7
7/21/94	MW4	320	0.51	1.4	1.0	1.6
10/19/94	MW4	750	ND	3.6	4.2	3.4
1/18/95	MW4	790	1.5	3.3	1.2	2.6
4/17/95	MW4	570	2.8	ND	3.3	3.9
7/18/95	MW4	340	1.0	1.9	2.8	2.7
4/10/91	MW5	630	35	14	47	30
7/10/91	MW5	220	5.1	8.7	9.1	9.7
10/14/91	MW5	660	55	4.4	50	66
1/14/92	MW5	99	1.0	1.2	ND	0.32
4/06/92	MW5	240♦	ND	ND	0.35	ND
7/07/92	MW5▲	76	0.48	1.1	0.32	1.3
10/16/92	MW5▲	180	7.8	1.1	17	6.4
1/14/93	MW5▲	91	ND	0.53	1.2	11
4/22/93	MW5▲	94	1.2	ND	ND	1.3
7/20/93	MW5▲	89	1.1	0.51	ND	1.8
10/20/93	MW5	110	0.80	ND	ND	ND
1/20/94	MW5	ND	ND	ND	ND	ND
4/21/94	MW5	ND	ND	ND	ND	ND
7/21/94	MW5	ND	ND	ND	ND	ND
10/19/94	MW5	ND	ND	0.71	ND	0.57
1/18/95	MW5	ND	ND	ND	ND	ND
4/17/95	MW5	ND	ND	ND	ND	ND
7/18/95	MW5	ND	ND	ND	ND	1.1
4/10/91	MW6	ND	ND	ND	ND	ND
7/10/91	MW6	ND	ND	ND	ND	ND
10/14/91	MW6	ND	ND	ND	ND	ND
1/14/92	MW6	ND	ND	ND	ND	ND
4/06/92	MW6	ND	ND	ND	ND	ND
7/07/92	MW6	ND	ND	ND	ND	ND
10/16/92	MW6	WELL WAS OBSTRUCTED				
1/14/93	MW6	WELL WAS OBSTRUCTED				
4/22/93	MW6	WELL WAS OBSTRUCTED				

**TABLE 3 (Continued)**

SUMMARY OF LABORATORY ANALYSES  
 WATER  
 UNOCAL MONITORING WELLS

Date	Well #	TPH as Gasoline	Benzene	Toluene	Ethyl-benzene	Xylenes	
7/20/93	MW6	WELL WAS OBSTRUCTED					
10/20/93	MW6	ND	ND	ND	ND	ND	
1/20/94	MW6	ND	ND	ND	ND	ND	
4/21/94	MW6	ND	ND	ND	ND	ND	
7/21/94	MW6	ND	ND	ND	ND	ND	
10/19/94	MW6	WELL WAS OBSTRUCTED BY ROOTS					
1/18/95	MW6	WELL WAS OBSTRUCTED BY ROOTS					
4/17/95	MW6	ND	ND	ND	ND	ND	
7/18/95	MW6	ND	ND	ND	ND	ND	
4/10/91	MW7	ND	ND	ND	ND	ND	
7/10/91	MW7	ND	ND	ND	ND	ND	
10/14/91	MW7	ND	ND	ND	ND	ND	
1/14/92	MW7	ND	ND	ND	ND	ND	
4/06/92	MW7	ND	ND	ND	ND	ND	
7/07/92	MW7	ND	ND	ND	ND	ND	
10/16/92	MW7	ND	ND	ND	ND	ND	
1/14/93	MW7	ND	ND	ND	ND	ND	
4/22/93	MW7	ND	ND	ND	ND	ND	
7/20/93	MW7	ND	ND	ND	ND	ND	
10/20/93	MW7	ND	ND	ND	ND	ND	
1/20/94	MW7	ND	ND	ND	ND	ND	
4/21/94	MW7	ND	ND	ND	ND	ND	
7/21/94	MW7	ND	ND	ND	ND	ND	
10/19/94	MW7	ND	ND	0.87	ND	0.61	
1/18/95	MW7	ND	ND	ND	ND	ND	
4/17/95	MW7	ND	ND	ND	ND	ND	
7/18/95	MW7	ND	ND	ND	ND	ND	

---

---

**TABLE 3 (Continued)**

SUMMARY OF LABORATORY ANALYSES  
WATER  
UNOCAL MONITORING WELLS

---

---

- \* TPH as diesel was non detectable.
- ◆ Sequoia Analytical Laboratory reported that the hydrocarbons detected did not appear to be gasoline.
- ▲ Methyl tert butyl ether was detected at a concentration of 2.2  $\mu\text{g/L}$  on July 20, 1993, 0.82  $\mu\text{g/L}$  on April 22, 1993, 1.2  $\mu\text{g/L}$  on January 14, 1994, 2.0  $\mu\text{g/L}$  on October 16, 1992, and 1.5  $\mu\text{g/L}$  on July 7, 1992.

ND = Non-detectable.

-- Indicates analysis was not performed.

Results are in micrograms per liter ( $\mu\text{g/L}$ ), unless otherwise indicated.

Note: Laboratory analyses data prior to January 20, 1994, were provided by Kaprealian Engineering, Inc.

**TABLE 4**

SUMMARY OF LABORATORY ANALYSES  
WATER  
UNOCAL MONITORING WELLS

Date	Well #	Total Oil & Grease mg/L	Trichlorethene µg/L	Chloroform µg/L
4/17/95	MW1	ND	ND	0.69
4/21/94	MW1	ND	ND	ND
7/10/91	MW1	ND	ND	ND
4/10/91	MW1	ND	ND	ND
12/24/90	MW1	ND	ND	ND
9/07/90	MW1	ND	ND	ND
6/05/90	MW1	ND	ND	ND
3/08/90	MW1	4.7	ND	ND
11/18/89	MW1	3.1	0.55	ND

ND = Non-detectable.

All EPA method 8010 constituents were non-detectable, except as indicated in above table.

mg/l = milligrams per liter.

Results are in micrograms per liter (µg/L), unless otherwise indicated.

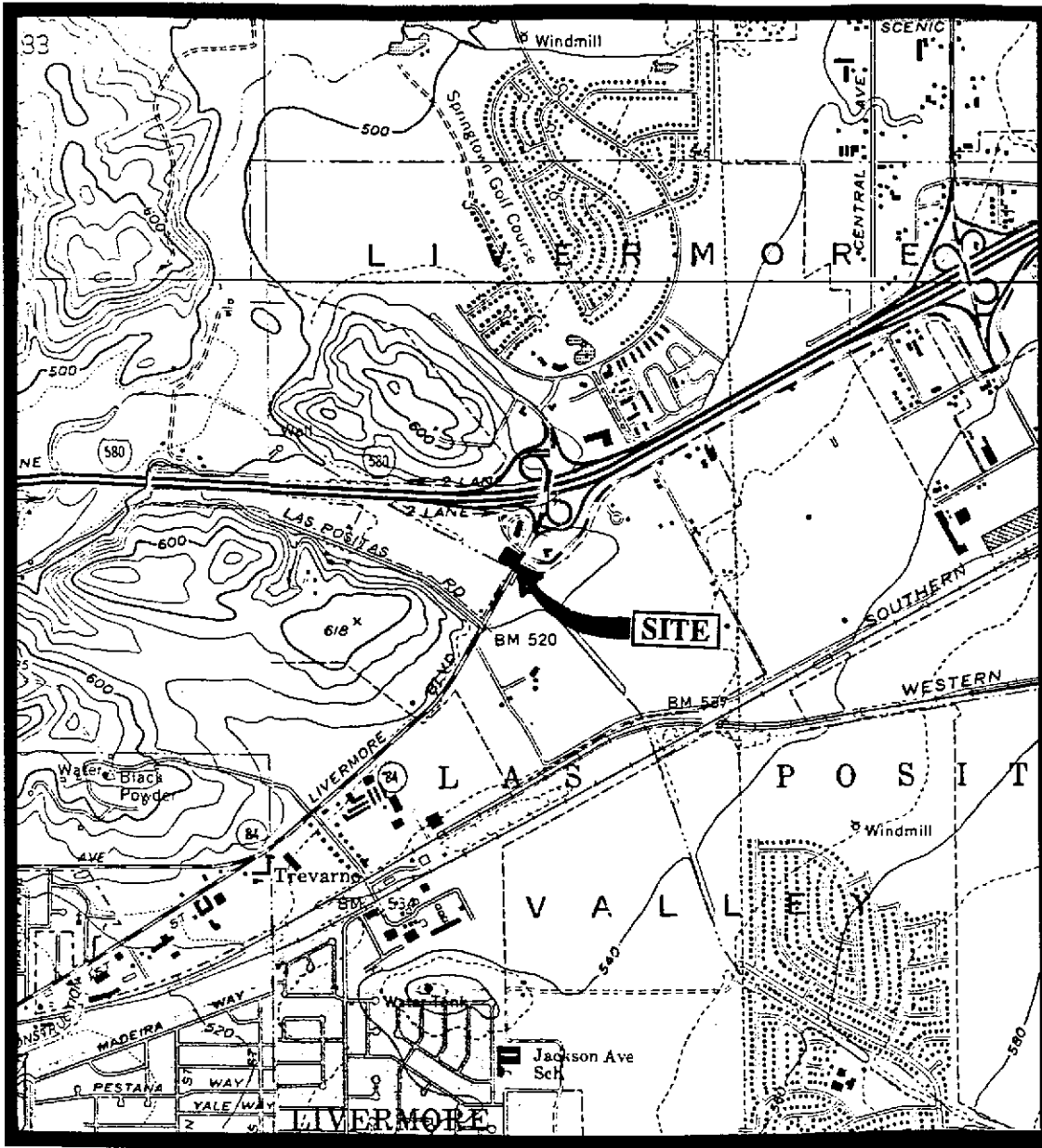

Base modified from 7.5 minute U.S.G.S. Livermore and Altamont Quadrangles  
 (photorevised 1980 and 1981, respectively)

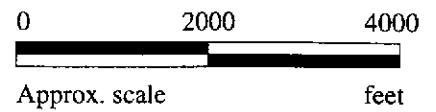

**MPDS** SERVICES, INCORPORATED

**UNOCAL SERVICE STATION # 6034  
 4700 FIRST STREET  
 LIVERMORE, CALIFORNIA**

**LOCATION  
 MAP**

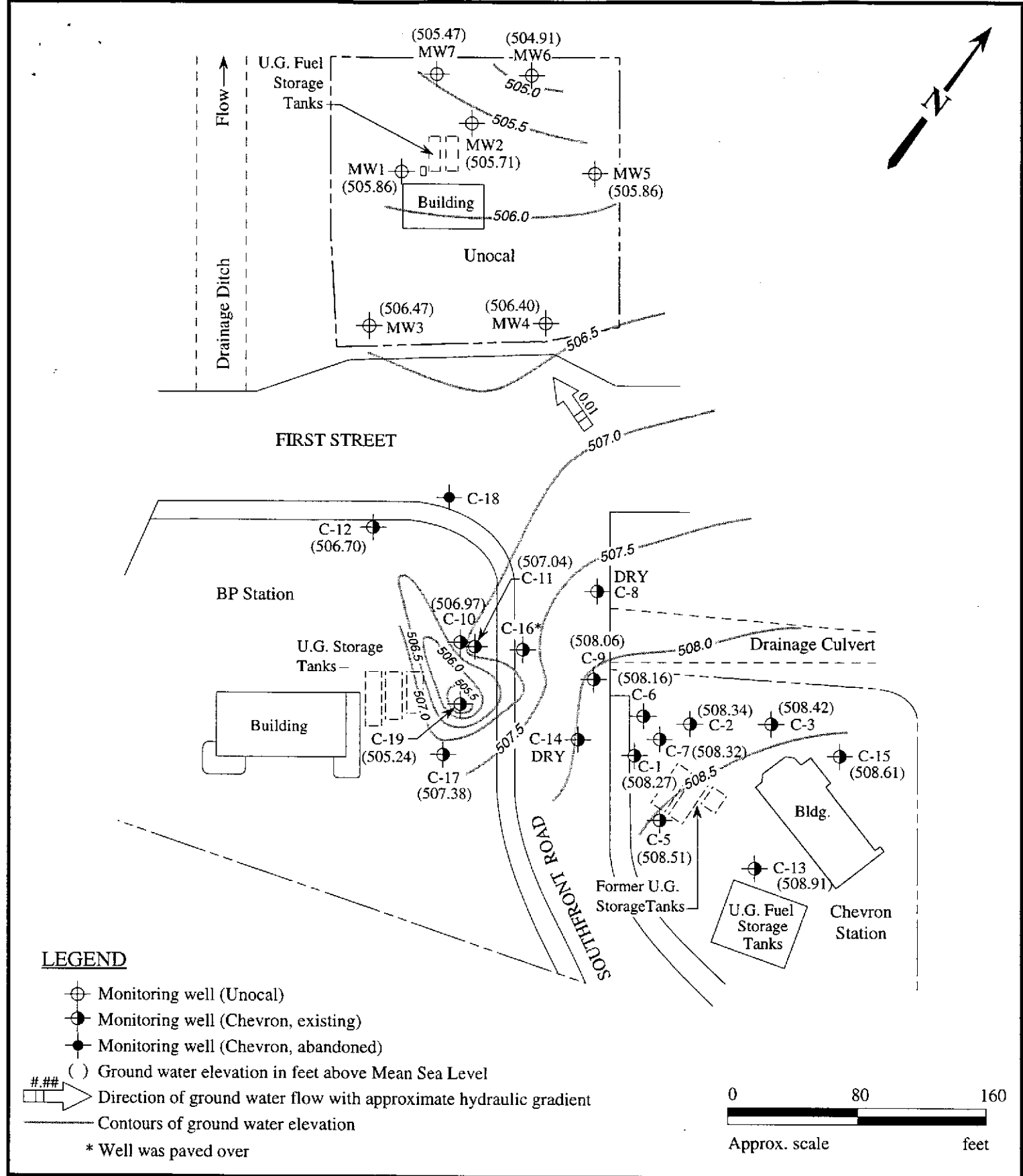

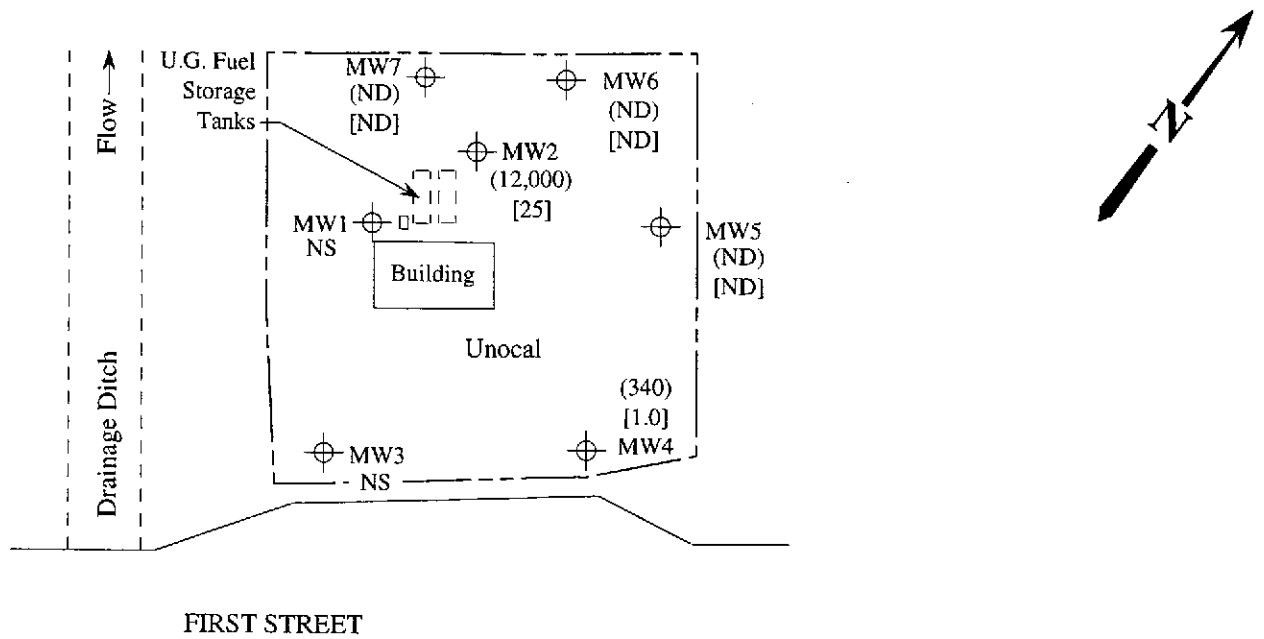

FIRST STREET

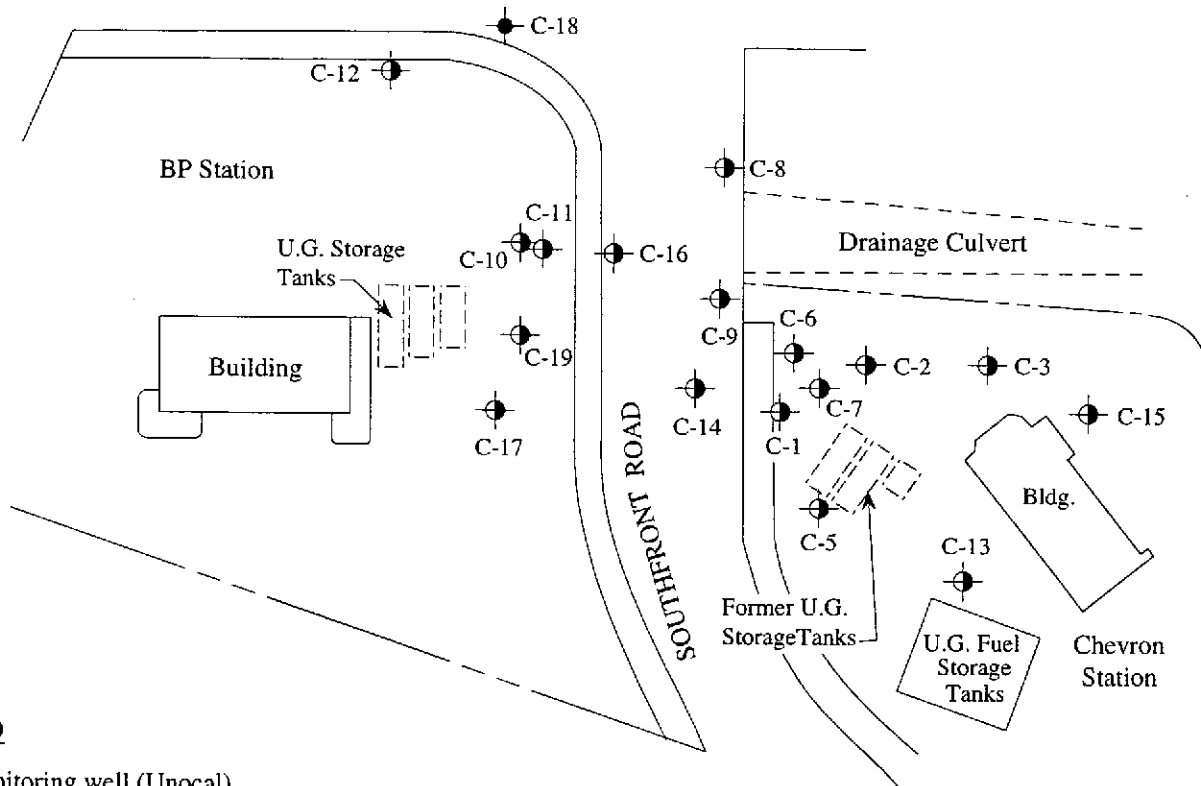

**LEGEND**

- ⊕ Monitoring well (Unocal)
- ⊙ Monitoring well (Chevron, existing)
- Monitoring well (Chevron, abandoned)
- ( ) Concentration of TPH as gasoline in  $\mu\text{g/L}$
- [ ] Concentration of benzene in  $\mu\text{g/L}$
- ND Non-detectable, NS Not sampled

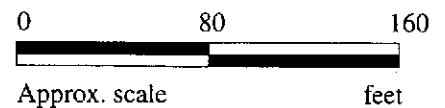

**PETROLEUM HYDROCARBON CONCENTRATIONS IN GROUND WATER ON JULY 18, 1995**



MPDS Services 2401 Stanwell Dr., Ste. 300 Concord, CA 94520 Attention: Sarkis Karkarian	Client Project ID: Unocal #6034, 4700 - 1st St., Livermore Matrix Descript: Water Analysis Method: EPA 5030/8015 Mod./8020 First Sample #: 507-1157	Sampled: Jul 18, 1995 Received: Jul 18, 1995 Reported: Jul 31, 1995
--	--	---

**TOTAL PURGEABLE PETROLEUM HYDROCARBONS with BTEX DISTINCTION**

Sample Number	Sample Description	Purgeable Hydrocarbons µg/L	Benzene µg/L	Toluene µg/L	Ethyl Benzene µg/L	Total Xylenes µg/L
507-1157	MW-2	12,000	25	24	550	3,700
507-1158	MW-4	340	1.0	1.9	2.8	2.7
507-1159	MW-5	ND	ND	ND	ND	1.1
507-1160	MW-6	ND	ND	ND	ND	ND
507-1161	MW-7	ND	ND	ND	ND	ND

<b>Detection Limits:</b>	<b>50</b>	<b>0.50</b>	<b>0.50</b>	<b>0.50</b>	<b>0.50</b>
--------------------------	-----------	-------------	-------------	-------------	-------------

Total Purgeable Petroleum Hydrocarbons are quantitated against a fresh gasoline standard.  
Analytes reported as ND were not present above the stated limit of detection.

**SEQUOIA ANALYTICAL, #1271**

Signature on File

Alan B. Kemp  
Project Manager







Sequoia  
Analytical

680 Chesapeake Drive  
404 N. Wiget Lane  
819 Striker Avenue, Suite 8

Redwood City, CA 94063  
Walnut Creek, CA 94598  
Sacramento, CA 95834

(415) 364-9600  
(510) 988-9600  
(916) 921-9600

FAX (415) 364-9233  
FAX (510) 988-9673  
FAX (916) 921-0100

MPDS Services 2401 Stanwell Dr., Ste. 300 Concord, CA 94520 Attention: Sarkis Karkarian	Client Project ID: Unocal #6034, 4700 - 1st St., Livermore Matrix Descript: Water Analysis Method: EPA 5030/8015 Mod./8020 First Sample #: 507-1157	Sampled: Jul 18, 1995 Received: Jul 18, 1995 Reported: Jul 31, 1995
--	--	---

### TOTAL PURGEABLE PETROLEUM HYDROCARBONS with BTEX DISTINCTION

Sample Number	Sample Description	Chromatogram Pattern	DL Mult. Factor	Date Analyzed	Instrument ID	Surrogate Recovery, % QC Limits: 70-130
507-1157	MW-2	Gasoline	40	7/21/95	HP-9	94
507-1158	MW-4	Gasoline	1.0	7/21/95	HP-9	97
507-1159	MW-5	--	1.0	7/21/95	HP-9	105
507-1160	MW-6	--	1.0	7/21/95	HP-9	107
507-1161	MW-7	--	1.0	7/21/95	HP-9	101

SEQUOIA ANALYTICAL, #1271

Signature on File

Alan B. Kemp  
Project Manager

5071157.MPD <2>





MPDS Services  
2401 Stanwell Dr., Ste. 300  
Concord, CA 94520  
Attention: Sarkis Karkarian

Client Project ID: Unocal #6034, 4700 - 1st St., Livermore  
Matrix: Liquid

QC Sample Group: 5071157-61

Reported: Jul 31, 1995

**QUALITY CONTROL DATA REPORT**

ANALYTE	Benzene	Toluene	Ethyl Benzene	Xylenes
<b>Method:</b>	EPA 8020	EPA 8020	EPA 8020	EPA 8020
<b>Analyst:</b>	A. Tuzon	A. Tuzon	A. Tuzon	A. Tuzon

<b>MS/MSD Batch#:</b>	5071152	5071152	5071152	5071152
<b>Date Prepared:</b>	7/21/95	7/21/95	7/21/95	7/21/95
<b>Date Analyzed:</b>	7/21/95	7/21/95	7/21/95	7/21/95
<b>Instrument I.D.#:</b>	HP-9	HP-9	HP-9	HP-9
<b>Conc. Spiked:</b>	20 µg/L	20 µg/L	20 µg/L	60 µg/L
<b>Matrix Spike % Recovery:</b>	115	120	120	130
<b>Matrix Spike Duplicate % Recovery:</b>	110	110	110	125
<b>Relative % Difference:</b>	4.4	8.7	8.7	3.9

<b>LCS Batch#:</b>	4LCS072195	4LCS072195	4LCS072195	4LCS072195
<b>Date Prepared:</b>	7/21/95	7/21/95	7/21/95	7/21/95
<b>Date Analyzed:</b>	7/21/95	7/21/95	7/21/95	7/21/95
<b>Instrument I.D.#:</b>	HP-9	HP-9	HP-9	HP-9
<b>LCS % Recovery:</b>	100	105	100	110

<b>% Recovery Control Limits:</b>	71-133	72-128	72-130	71-120
---------------------------------------	--------	--------	--------	--------

**Please Note:**

The LCS is a control sample of known, interferent free matrix that is analyzed using the same reagents, preparation, and analytical methods employed for the samples. The matrix spike is an aliquot of sample fortified with known quantities of specific compounds and subjected to the entire analytical procedure. If the recovery of analytes from the matrix spike does not fall within specified control limits due to matrix interference, the LCS recovery is to be used to validate the batch.

**SEQUOIA ANALYTICAL, #1271**

Signature on File

Alan B. Kemp  
Project Manager



# M P D S Services, Inc.

2401 Stanwell Drive, Suite 400, Concord, CA 94520  
 Tel: (510) 602-5120 Fax: (510) 689-1918

## CHAIN OF CUSTODY

SAMPLER (JOE) HOVSIA AJEMIAN			UNOCAL S/S # <u>6034</u> CITY: <u>Livermore</u>					ANALYSES REQUESTED							TURN AROUND TIME: <u>Regular</u>	
WITNESSING AGENCY			ADDRESS: <u>4700 1st St.</u>					TPH-GAS BTEX	TPH-DIESEL	TOG	8010					REMARKS
SAMPLE ID NO	DATE	TIME	<input checked="" type="checkbox"/> WATER	<input checked="" type="checkbox"/> GRAB	<input type="checkbox"/> COMP	NO OF CONT	SAMPLING LOCATION									
MW-2	7-18-95	2:30 P.M.	<input checked="" type="checkbox"/>	<input checked="" type="checkbox"/>		2(VOA)	Wells	<input checked="" type="checkbox"/>		5071157	AB					No. 5 gas and
MW-4	"	11:48 P.M.	<input checked="" type="checkbox"/>	<input checked="" type="checkbox"/>		"	"	<input checked="" type="checkbox"/>		5071158						
MW-5	"	11:08 P.M.	<input checked="" type="checkbox"/>	<input checked="" type="checkbox"/>		"	"	<input checked="" type="checkbox"/>		5071159						
MW-6	"	11:40 P.M.	<input checked="" type="checkbox"/>	<input checked="" type="checkbox"/>		"	"	<input checked="" type="checkbox"/>		5071160						
MW-7	"	12:18 P.M.	<input checked="" type="checkbox"/>	<input checked="" type="checkbox"/>		"	"	<input checked="" type="checkbox"/>		5071161	↓					
RELINQUISHED BY:			DATE/TIME 19 5:30 P.M.		RECEIVED BY:			THE FOLLOWING <u>MUST BE</u> COMPLETED BY THE LABORATORY ACCEPTING SAMPLES FOR ANALYSES:								
(SIGNATURE) <u>Joe Ajemian</u>			7-18-95		(SIGNATURE) <u>[Signature]</u>			1. HAVE ALL SAMPLES RECEIVED FOR ANALYSIS BEEN STORED ON ICE?								
(SIGNATURE) <u>[Signature]</u>			7-19		(SIGNATURE) <u>[Signature]</u>			2. WILL SAMPLES REMAIN REFRIGERATED UNTIL ANALYZED?								
(SIGNATURE)					(SIGNATURE)			3. DID ANY SAMPLES RECEIVED FOR ANALYSIS HAVE HEAD SPACE?								
(SIGNATURE)					(SIGNATURE)			4. WERE SAMPLES IN APPROPRIATE CONTAINERS AND PROPERLY PACKAGED?								
(SIGNATURE)					(SIGNATURE) <u>[Signature]</u> 7-18-95 1710			SIGNATURE <u>[Signature]</u>		TITLE: <u>Analyst</u>		DATE: <u>7-18-95</u>				

David: PH Vol 1/19/95 4:00 am