

**RECEIVED**

By dehloptoxic at 1:31 pm, Jun 28, 2006



December 15, 2005

The Bank of New York Trust Company, N.A. as Corporate Co-Trustee for  
Carpenters Pension Trust Fund for Northern California; Northern California Carpenters PTF, LLC  
c/o Ms. Mary Schroeder, McMorgan & Company LLC  
One Bush Street, Suite 800  
San Francisco, California 94104

RE: Work Plan – Additional Subsurface Investigation  
444 Hegenberger Loop, Oakland, California  
*ACC Project Number 6748-017-01*

Dear Ms. Schroeder:

ACC Environmental Consultants, Inc., (ACC) presents this Work Plan (WP) to perform additional subsurface investigation at 444 Hegenberger Loop, Oakland, California (Site). The purpose is to further characterize suspected total petroleum hydrocarbon (TPH) impacts in soil and groundwater in the vicinity of the former underground storage tanks (USTs) and suspected TPH impacts in groundwater outside the existing network of groundwater monitoring wells. The Alameda County Health Care Services Agency (ACHCSA) is the lead agency and additional site characterization is required according to draft *Proposed Methodologies to Clarify Expectations for Site Closures* at Local Oversight Program (LOP) / Spills, Leaks, Investigations and Cleanups (SLIC) cases.

## INTRODUCTION

The general goals of this proposed additional site investigation are two-fold. One goal is to collect the additional site characterization data necessary to evaluate the Site for closure as a “release identified as not having off-site consequences and future use of property is to remain commercial in nature, and with a known water impact.” The second goal is to obtain additional data for the Site Conceptual Model (SCM) and to evaluate applicable environmental screening levels (ESLs), human health screening levels (HHSLS), and preliminary remediation goals (PRGs) in regards to suspected residual TPH impacts in soil and groundwater.

Specific work tasks to achieve these two goals include: 1) advance 10 exploratory soil borings and collect selected soil and grab groundwater samples to further characterize subsurface conditions in the vicinity of the former underground storage tanks (USTs) and further characterize groundwater conditions outside the existing network of groundwater monitoring wells.; 2) determine the potential for vertical and horizontal migration of TPH in the subsurface; 3) obtain additional data regarding human health and ecological risk associated with suspected residual TPH in the subsurface; and 4) prepare a report of findings for

submission to the ACHCSA for purposes of evaluating the Site for full regulatory closure in regards to the former USTs.

TPH-impacted soil is likely beneath and adjacent to the former USTs and product dispensers, and TPH-impacted groundwater is likely localized in the immediate downgradient direction to the northwest. However, the extent and degree of TPH impact must be further defined and document that any off site impacts are insignificant. Soil and grab groundwater sampling will likely indicate that significant natural attenuation and degradation of residual TPH in soil and groundwater has occurred since the USTs were removed in March 1989 and the remaining residual TPH in soil and groundwater does not pose an unacceptable human health risk in a commercial land use scenario.

## **BACKGROUND**

The Site is located at 444 Hegenberger Loop in the southeast corner of the intersection of Hegenberger Road and Hegenberger Loop. The rectangular lot is approximately 250 feet long by 200 feet wide and is approximately 9 feet above mean sea level. The available data indicate that a series of subsurface investigations have been conducted at the Site since 1997. A site assessment in April 1997 indicated the presence of petroleum hydrocarbons in soils and groundwater beneath the Site but no reportable concentrations of methyl tertiary butyl ether (MTBE). A subsequent investigation conducted in July and October 1997 confirmed previous investigation findings and that no underground storage tanks (USTs) remained at the Site.

Tetra Tech EM Inc. (Tetra Tech) installed five 2-inch-diameter groundwater monitoring wells in November 1998. The five monitoring wells were screened from 5 to 20 feet below ground surface (bgs). Well MW-1 was subsequently destroyed in December 1999 and well MW-6 was installed in the estimated downgradient direction of the former waste oil tank. Well MW-6 was screened from 10 to 20 feet bgs. In December 2000, Tetra Tech installed offsite wells MW-7 and MW-8 estimated to be in the downgradient direction of the Site. Wells MW-7 and MW-8 were screened from 5 to 20 feet bgs. Groundwater monitoring was performed periodically from December 1998 to October 2001 in the existing wells.

Tetra Tech reported the findings of a Sensitive Receptor Survey in its March 8, 2001 *Fourth Quarter Groundwater Monitoring Report, December 2000*. According to the California Department of Water resources, 40 monitoring wells and two irrigation wells were located at 11 sites within the search distance. One irrigation well is reportedly located approximately 500 feet cross gradient from the Site and a second irrigation well is located approximately 2,800 feet crossgradient of the Site.

### **Subsurface Conditions**

Soil boring logs from wells MW-7 and MW-8, included in the March 8, 2001 *Fourth Quarter Groundwater Monitoring Report, December 2000*, indicate that clay and silty clay is present from the surface to the minimum depth of 11.5 feet bgs and sandy gravels and sands are present from approximately 12 to 15 feet bgs to 20.0 feet bgs, the total depth of the soil borings. Silty clays logged at 10 to 10.5 feet bgs are described as dry to moist, medium plasticity, and medium stiff. Sandy gravels logged from 15 to 16 feet bgs are described as saturated, coarse to fine grained sand, and fine to medium grained gravel, and poorly graded, loose sand (SP) is present at 20 feet bgs.

The data summarized in the soil boring logs directly contradicts other conclusions presented in the March 8, 2001 *Fourth Quarter Groundwater Monitoring Report, December 2000*. In the *Subsurface Soil*

*Conditions and Hydrology* section of the report, Tetra Tech states that “Groundwater is usually encountered within five feet bgs,” and in the *Preferential Pathways* section “the utility trenches may act as preferential pathways and could allow for movement of petroleum hydrocarbons to the north and west beyond the site.” Saturated permeable soils are not logged shallower than 12 feet bgs and the depth to groundwater cited by Tetra Tech is actually semi-confined groundwater which has risen in the monitoring wells. Utility trenches in the vicinity of the Site likely exist no deeper than six feet bgs, therefore, interception or preferential movement of groundwater along utility trenches is highly unlikely. The depth to groundwater measured in the monitoring wells represents a potentiometric surface due to semi-confined aquifer conditions and the reported groundwater depths recorded in the monitoring wells coincides with relatively impermeable clays outside the wells.

The calculated groundwater flow direction varies slightly but the predominant flow direction is northwest. This direction is consistent with surface topography and surface drainage via the San Leandro Creek located northwest of the Site.

#### **RATIONALE FOR PROPOSED SCOPE OF WORK**

Hydropunch data indicating elevated petroleum hydrocarbon concentrations in exploratory soil borings advanced at the Site is approximately eight years old. Groundwater monitoring analytical results indicate that relatively minor residual sources of TPH impact still exist in soil but that no significant or localized sources of soil impact to groundwater are apparent. In order to further evaluate potential soil sources of impact to groundwater, ACC contoured TPHg and benzene concentrations in groundwater using Surfer<sup>®</sup> interpolation software. Isoconcentration contours tended to form a distinct “bulls-eye” around well MW-3 or approximated a southeast to northwest-trending plume with decreasing concentration with distance. No information was apparent to explain the “bulls-eye” around well MW-3 so grab groundwater samples collected in soil borings B-7 through B-9 should provide necessary data to evaluate suspect TPH impacts in groundwater in the vicinity of well MW-3. In addition, since previously calculated groundwater flow directions were to the north, grab groundwater samples collected in soil borings B-9 and B-10 should provide additional data to further evaluate suspect TPH impacts in groundwater north of potential onsite source areas.

In order to obtain current residual TPH concentrations in soil and to further evaluate residual TPH concentrations suspected in soil at specific locations, ACC proposes to collect representative soil samples in proposed soil borings B-1 through B-8. In order to collect water quality data outside the existing network of monitoring wells, ACC proposes to collect grab groundwater samples in proposed soil borings B-5 through B-10. The ten Geoprobe<sup>®</sup> exploratory soil borings will be advanced to depths ranging from 8 to 30 feet bgs at select locations estimated to provide the optimum data regarding subsurface conditions. Grab groundwater samples will be collected in the first-encountered saturated zone from 13 to 17 feet bgs. Previous subsurface investigations logged saturated sands to 20 feet bgs so ACC will log soil to 30 feet bgs to evaluate soils below 20 feet bgs and determine the need to advance soil borings deeper than 30 feet or collect grab groundwater samples deeper than 13 to 17 feet bgs. Proposed soil boring locations are illustrated on Figure 3 and proposed sample depths and analyses are summarized in Table 1. TPHg and BTEX are the primary constituents of concern and TPHd is not considered a constituent of concern based on monitoring well analytical results.

**TABLE 1 – PROPOSED SAMPLE ANALYSES**

Soil Boring	Depth	Matrix	Constituent Analysis
B1	3.5-4.0	Soil	TPHg, BTEX, MTBE
	7.5-8.0	Soil	TPHg, BTEX, MTBE
B2	3.5-4.0	Soil	TPHg, BTEX, MTBE
	7.5-8.0	Soil	TPHg, BTEX, MTBE
B3	3.5-4.0	Soil	TPHg, BTEX, MTBE
	7.5-8.0	Soil	TPHg, BTEX, MTBE
B4	3.5-4.0	Soil	TPHg, BTEX, MTBE
	7.5-8.0	Soil	TPHg, BTEX, MTBE
B5	8.5-9.0	Soil	TPHg, BTEX, MTBE
	11.5-12.0	Soil	TPHg, BTEX, MTBE
	13-17	Water	TPHg, BTEX, MTBE
B6	8.5-9.0	Soil	TPHg, BTEX, MTBE
	11.5-12.0	Soil	TPHg, BTEX, MTBE
	13-17	Water	TPHg, BTEX, MTBE
	23.5-24.0	Soil (dry)	TPHg, BTEX, MTBE
B7	13-17	Water	TPHg, BTEX, MTBE
B8	13-17	Water	TPHg, BTEX, MTBE
	23.5-24.0	Soil (dry)	TPHg, BTEX, MTBE
B9	13-17	Water	TPHg, BTEX, MTBE
B10	13-17	Water	TPHg, BTEX, MTBE

Results of soil analytical data obtained from the 350 cubic yards of soil formerly stockpiled at the Site were nondetect for gasoline constituents. While records do not conclusively prove how the stockpiled soil was disposed, it is believed the majority of the stockpiled soil was used to backfill excavations and the remainder was spread around the site. Based on the additional analytical results obtained by Northwest Environcon Inc. in April 1996, the former stockpiled soil does not appear to be responsible for residual TPH reported in groundwater samples collected in the existing groundwater monitoring wells.

Soil borings B-6 and B-8 will be continuously cored to approximately 30 feet in order to prepare a cross-section with soil data previously logged during the installation of monitoring well MW-8. This information will be incorporated in the SCM. Proposed soil samples below 12.0 feet bgs will only be collected in dry to moist soils deemed to be aquitard material and will not be collected for analysis in wet soil.

ACC proposes to compare sample analytical results with TPHg and BTEX environmental screening levels (ESLs) promulgated by the RWQCB. Due to the lack of mitigating factors and the likely scenario of long-term commercial site use, ESLs appear appropriate for a Tier 1 risk evaluation. While elevated TPHg and BTEX concentrations were reported in soil and grab groundwater samples eight years ago, significant attenuation and weathering has likely occurred. The extent of this expected attenuation will warrant whether additional subsurface characterization or possible residual source removal is warranted.

All soil borings will be continuously-cored, logged, and screened for field indications of TPH impact. Vadose and saturated soils will be specifically logged for their estimated permeability and migration potential. Soil screening for volatile constituents will be performed approximately every one to two feet

with a calibrated ppbRAE photoionization detector (PID) to prioritize potential soil samples for analysis. Soil samples obtained for analysis will be prioritized according to the following criteria: 1) soil samples exhibiting the highest PID readings; 2) soil samples exhibiting field indications of impact such as odor and discoloration; and 3) soil samples collected above first-encountered groundwater with no apparent TPH impacts shallower in vadose soil in the soil boring.

## **SCOPE OF WORK**

ACC proposes the following scope of work to further characterize subsurface conditions at the Site and obtain the data necessary to evaluate the case for full regulatory closure:

- Advance 10 continuously-cored exploratory soil borings to total depths of approximately 8 to 30 feet bgs to log encountered soils and collect representative soil and grab groundwater samples;
- Advance select soil borings in proximity to the former product dispensers and USTs and at appropriate distances from the former USTs to assess suspect petroleum hydrocarbon impacts in soil and groundwater;
- Collect representative soil and grab groundwater samples from the logged, continuously cored soil borings; proposed analyses are summarized in Table 1 and proposed soil boring locations are shown on Figure 3;
- Submit each soil and grab groundwater sample to a state certified analytical laboratory for analysis of TPHg, BTEX, and MTBE by EPA Method 8260B;
- Obtain available data regarding the depth and location of utility trenches along Hegenberger Road and Hegenberger Loop and include this data in the final report;
- Prepare a cross-section using logged soil data from soil borings B-6 through B-8 and monitoring well MW-8 and include this data in the final report; and
- Prepare a report of findings for submission to the ACHCSA.

All work will be performed according to Tri-Regional Guidelines set forth by the San Francisco Bay Regional Water Quality Control Board (RWQCB), and standard ACC sampling protocols.

## **DRILLING PROGRAM**

A drilling permit will be obtained from the Alameda County Public Works Department prior to fieldwork. The proposed soil boring locations are illustrated on Figure 3. Due to the location of utilities and safety and traffic control considerations on Hegenberger Road, all soil borings will be advanced on the property. All soil borings will be clearly marked and outlined in white paint. Underground Service Alert will be notified at least 2 business days prior to performing drilling activities. ACC has monitored the existing monitoring wells and proposes to advance soil borings B-1 through B-10 at specified locations due to physical limitations and safety purposes.

Exploratory soil borings will be advanced using approved rapid assessment, direct-push technology. The soil borings will be advanced using a truck-mounted, hydraulically-driven Geoprobe™ sampling tool equipped with 2.0-inch inside-diameter clear acetate liners. Drilling will be performed under the direction of a Professional Geologist, and the subsurface materials in the borings will be identified and logged according to the Unified

Soil Classification System. The sampling probe and rods will be pre-cleaned prior to use and between drives by washing them with a trisodium phosphate and two tap water rinses. The work will be conducted during two 8-hour days and soil cuttings will be containerized, labeled, and stored onsite pending profiling results.

Grab groundwater samples will be collected in each proposed boring by installing new slotted and solid 1-inch diameter PVC casing in each open hole and bailing the temporary casing with a disposable 0.5-inch-diameter polyethylene bailer. Following bailing of one to two casing volumes in each respective PVC well casing, the bailer will be filled approximately 12 inches below the top of the water in the casing and a sample transferred to laboratory-supplied sample containers. Turbidity will be assessed in groundwater in each soil boring to determine if purging each respective PVC casing is warranted prior to collecting the grab groundwater sample. Every effort will be made to standardize the collection of grab groundwater samples to minimize variation due to sampling methodology.

Each grab groundwater sample will be immediately placed in approved, laboratory-supplied sample vials without headspace, sealed, and stored in a pre-chilled, insulated container pending transport to a state-certified analytical laboratory. Every effort will be made to minimize disturbance of the groundwater samples prior to placement in the sample containers and maintaining the samples at 4 degrees Celsius prior to analysis. The samples will be submitted to a state-certified analytical laboratory following standard chain of custody procedures for analysis. Standard turnaround time for analytical results is five working days. Following drilling and sample collection, each soil boring will be abandoned with neat cement to just below the surface (3 to 6 inches) and will then be completed with concrete or soil to grade to match the surface.

## **REPORT PREPARATION**

A technical report discussing fieldwork, observations and findings, analytical results, conclusions, and recommendations will be prepared for submission to the ACHCSA. The report will contain copies of all permits and sampling protocols used during the investigation. In addition, a site-specific health and safety plan which encompasses the proposed work at the site and complies with the requirements of 29 CFR Part 1910.120 will be prepared and present during field activities.

If you have any questions concerning this work plan, please call me at (510) 638-8400, ext. 109 or email me at [ddement@accenv.com](mailto:ddement@accenv.com).

Sincerely,



David R. DeMent, PG, REA II  
Environmental Division Manager

/drd:kld

cc: Mr. Barney Chan, ACHCSA

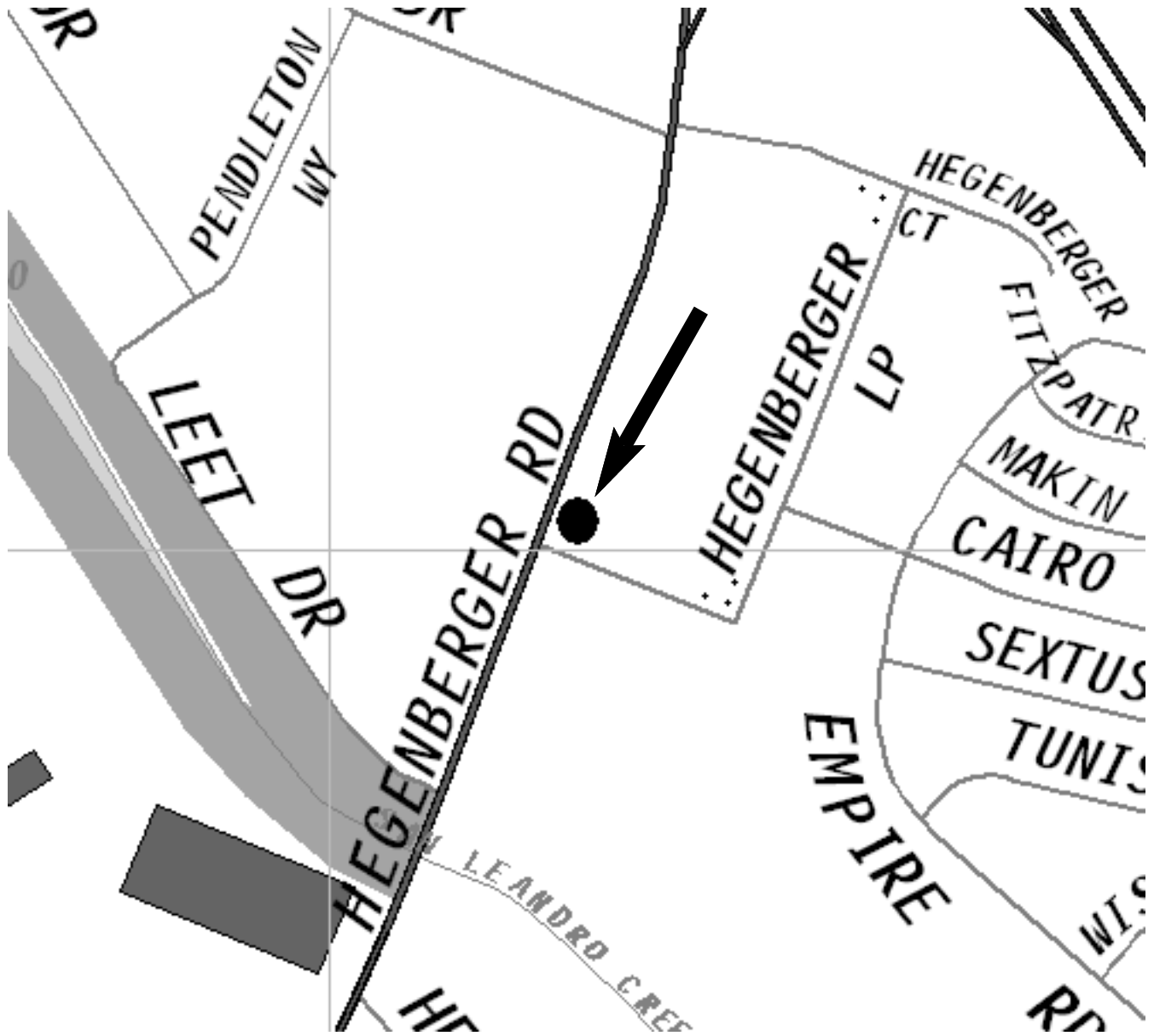

Source: The Thomas Guide, Bay Area, 2004

Title: **Location Map**  
**444 Hegenberger Loop**  
**Oakland, California**

Figure Number: 1

Scale: None

Project Number: 6748-017

Drawn By: TRB

Date: 12/9/05



7977 Capwell Drive, Suite 100  
 Oakland, California 94621  
 (510) 638-8400 Fax: (510) 638-8404

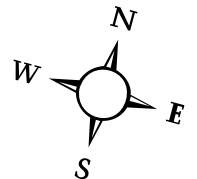

MW-8

HEGENBERGER ROAD

MW-7

HEGENBERGER LOOP

MW-3

MW-4

former dispenser islands

MW-2

MW-6

MW-5

former UST areas

MW-1  
(DESTROYED)

### Legend



Groundwater Monitoring Well Location

Title: **Site Plan**  
**444 Hagenberger Loop**  
**Oakland, California**

Figure Number: 2

Scale: 1" = 60'

Project Number: 6748-017-01

Drawn By: ANW

Date: 12/9/05



7977 Capwell Drive, Suite 100  
Oakland, California 94621  
(510) 638-8400 Fax: (510) 638-8404

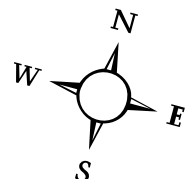



MW-8



### HEGENBERGER ROAD

MW-7

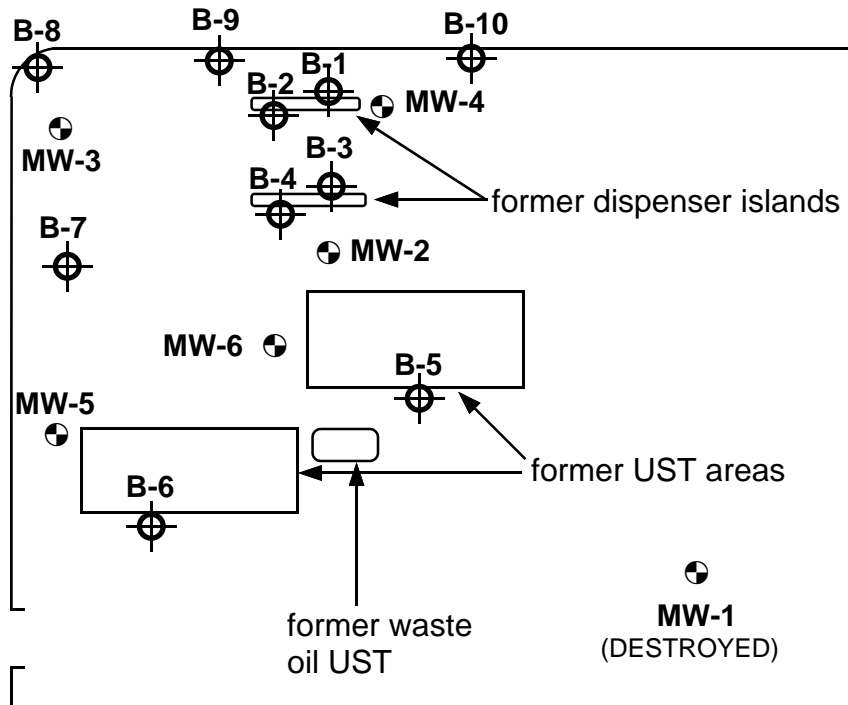
### HEGENBERGER LOOP



### Legend

-  Groundwater Monitoring Well Location
-  Proposed Soil Boring Location

Title: **Proposed Soil Boring Locations  
444 Hagenberger Loop  
Oakland, California**

Figure Number: 3

Scale: 1" = 60'

Project Number: 6748-017-01

Drawn By: DRD

Date: 12/09/05



7977 Capwell Drive, Suite 100  
Oakland, California 94621  
(510) 638-8400 Fax: (510) 638-8404

