

ENVIRONMENTAL
PROTECTION

00 MAY -1 PM 4:50



Chevron

Chevron U.S.A. Products Company
6001 Edinger Canyon Rd. Bldg. L
P. O. Box 6004
San Ramon, CA 94583-9804

Site Assessment and
Remediation Group
Phone (510) 842-9570
Fax (510) 842-9570

Date: April 28, 2000
To: Distribution
Re: Groundwater Monitoring Report

The enclosed groundwater monitoring report has been properly reviewed by a Chevron authorized representative. Agency guidelines have been followed. Elaine Tech Services is authorized to distribute the report directly to interested parties.

If you have any questions, please call me at (510) 842-8695

Sincerely,

A handwritten signature in cursive script that reads "Bret L. Hunter".

Bret Hunter
Site Assessment and Remediation
Project Manager

BLAINE
TECH SERVICES, INC.



1680 ROGERS AVENUE
SAN JOSE, CA 95112-1105
(408) 573-7771 FAX
(408) 573-0555 PHONE
CONTRACTOR'S LICENSE #746684
www.blainetech.com

April 26, 2000

Brett Hunter
Chevron U.S.A. Products Company
P.O. Box 6004
San Ramon, CA 94583-0904

1st Quarter 2000 Monitoring at 9-0020

First Quarter 2000 Groundwater Monitoring at
Former Chevron Service Station Number 9-0020
1633 Harrison Street
Oakland, CA

Monitoring Performed on March 27, 2000

Groundwater Sampling Report 000327-F-1

This report covers the routine monitoring of groundwater wells at this Chevron facility. Blaine Tech Services, Inc.'s work at the site includes inspection, gauging, evacuation, purgewater containment, sample collection and sample handling in accordance with standard procedures that conform to Regional Water Quality Control Board requirements.

Routine field data collection includes depth to water, total well depth, thickness of any separate immiscible layer, water column volume, calculated volume of a three-case volume purge, elapsed evacuation time, total volume of water removed, and standard water parameter instrument readings. Sample material is collected, contained, stored, and transported to the laboratory in conformance with EPA standards. Purgewater is, likewise, collected and transported to McKittrick Waste Treatment Site for disposal.

Basic field information is presented alongside analytical values excerpted from the laboratory report in the cumulative table of **WELL DATA AND ANALYTICAL RESULTS**. The full analytical report for the most recent samples is located in the **Analytical Appendix**. The table also contains new groundwater elevation calculations taken from the computer plotted gradient

map which is located in the **Professional Engineering Appendix**.

At a minimum, Blaine Tech Services, Inc. field personnel are certified upon completion of a forty-hour Hazardous Materials and Emergency Response training course per 29 CFR 1910.120. Field personnel are also enrolled in annual eight hour refresher courses.

Blaine Tech Services, Inc. conducts sampling and documentation assignments of this type as an independent third party. In order to avoid compromising the objectivity necessary for the proper and disinterested performance of this work, Blaine Tech Services, Inc. concentrates on objective data collection and does not participate in the interpretation of analytical results, the definition of geological or hydrological conditions, the formulation of recommendations, or the marketing of remedial systems.

Please call if you have any questions.

Yours truly,



Scott Boor
Project Coordinator

SDB/jh

attachments: Professional Engineering Appendix
Cumulative Table of Well Data and Analytical Results
Analytical Appendix
Field Data Sheets

cc: Don Hwang, Alameda County Health Care Services
Howard Davis, The Oakland Housing Authority
Greg Gurss, Gettler-Ryan, Inc.

Professional Engineering Appendix

Table of Well Data and Analytical Results



SCALE (ft)



NA
MW-16

Ø MW-11

Ø MW-12

Ø MW-14 17th STREET

Ø MW-13
8.58

Ø MW-15
8.37

9.0

HARRISON STREET



Ø MW-9
NA

Ø MW-10

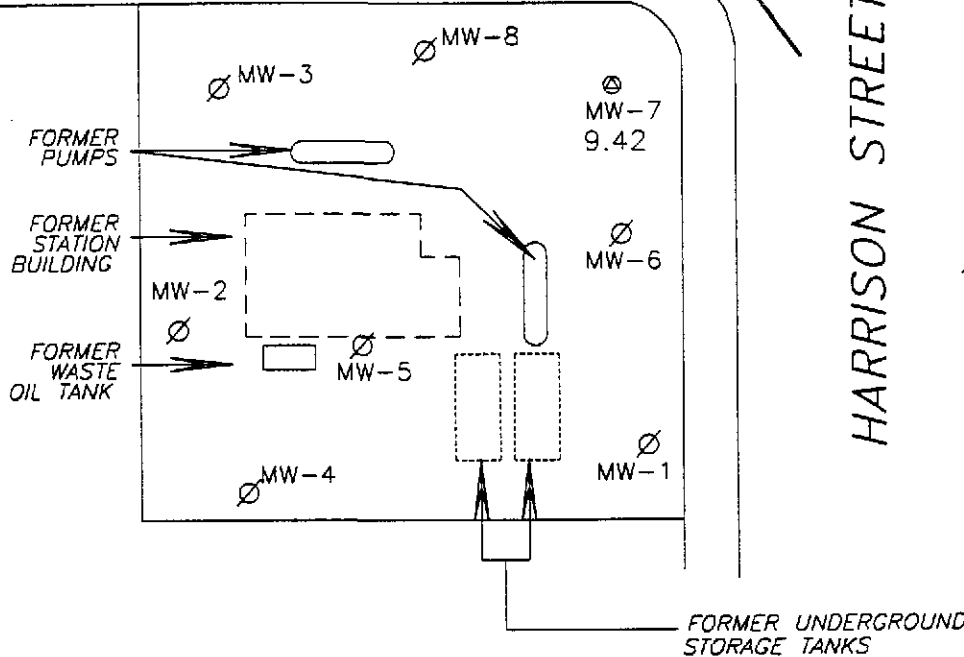

EXPLANATION

- ⊙ MONITORING WELL
- Ø ABANDONED WELL
- 9.42 GROUNDWATER ELEVATION (FT, MSL)
- 9.0 — GROUNDWATER ELEVATION CONTOUR (FT, MSL)
- ➔ APPROXIMATE GROUNDWATER FLOW DIRECTION;
APPROXIMATE GRADIENT = 0.01

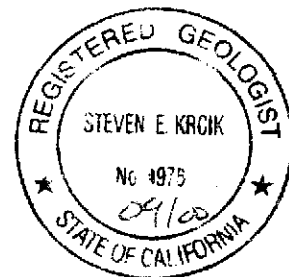

Basemap from Geoconsultants, Inc.

PREPARED BY

RRM
engineering contracting firm

Former Chevron Station 9-0020
1633 Harrison Street
Oakland, California

GROUNDWATER ELEVATION MAP,
MARCH 27, 2000

FIGURE:
1
PROJECT:
DAC04

Cumulative Table of Well Data and Analytical Results

Vertical Measurements are in feet.

Analytical results are in parts per billion (ppb)

DATE	Well Head Elev.	Ground Water Elev.	Depth To Water	Notes	TPH-Gasoline	Benzene	Toluene	Ethyl-Benzene	Xylene	MTBE	TOG
MW-1											
11/03/88	29.82	9.42	20.40	--	<1000	<1.0	<1.0	<1.0	<1.0	--	--
02/02/89	29.82	9.11	20.71	--	--	--	--	--	--	--	--
02/10/89	29.82	--	--	--	<100	<0.2	<0.2	<0.2	<0.4	--	--
04/23/89	29.82	9.48	20.34	--	--	--	--	--	--	--	--
04/24/89	29.82	--	--	--	<50	<0.5	<1.0	<1.0	<1.0	--	<3000
07/28/89	29.82	9.24	20.58	--	<50	<0.1	<0.5	<0.2	<0.5	--	<3000
10/30/89	29.82	9.30	20.52	--	<500	<0.3	<0.3	<0.3	<0.6	--	--
01/09/90	29.82	9.05	20.77	--	<50	<0.3	<0.3	<0.3	<0.6	--	--
04/18/90	29.82	8.87	20.95	--	<50	<0.3	<0.3	<0.3	<0.6	--	--
06/22/90	29.82	8.82	21.00	--	--	--	--	--	--	--	--
08/09/90	29.82	8.88	20.94	--	<50	<0.3	<0.3	<0.3	<0.6	--	--
11/13/90	29.82	8.84	20.98	--	<50	<0.5	<0.5	<0.5	<0.5	--	--
05/15/91	29.82	9.18	20.64	--	<50	<0.5	<0.5	<0.5	<0.5	--	--
08/27/91	29.82	9.03	20.79	--	110	<0.5	<0.5	<0.5	<0.5	--	--
11/15/91	29.82	9.07	20.75	--	<50	<0.5	<0.5	<0.5	<0.5	--	--
02/20/92	29.82	8.92	20.90	--	<50	0.5	0.6	<0.5	0.9	--	--
06/15/92	29.82	9.18	20.64	--	<50	<0.5	<0.5	<0.5	<0.5	--	--
12/16/92	29.82	8.98	20.84	--	<50	<0.5	<0.5	<0.5	<0.5	--	--
04/07/93	29.82	9.91	19.91	--	<50	<0.5	<0.5	<0.5	<1.5	--	--
06/09/93	29.82	9.97	19.85	--	--	--	--	--	--	--	--
09/10/93	29.82	--	--	--	--	--	--	--	--	--	--
09/27/93	29.82	9.47	20.35	--	<50	<0.5	<0.5	<0.5	<0.5	--	--
12/17/93	29.82	9.14	20.68	--	<50	<0.5	<0.5	<0.5	<0.5	--	--
03/10/94	29.82	9.25	20.57	--	<50	<0.5	<0.5	<0.5	<0.5	--	--
06/16/94	29.82	9.27	20.55	--	<50	<0.5	<0.5	<0.5	<0.5	--	--
09/07/94	29.82	9.13	20.69	--	<50	<0.5	<0.5	<0.5	<0.5	--	--
11/30/94	29.82	9.59	20.23	--	<50	<0.5	<0.5	<0.5	<0.5	--	--
03/22/95	29.82	10.37	19.45	--	<50	<0.5	<0.5	<0.5	<0.5	--	--
01/17/98	--	--	--	Abandoned	--	--	--	--	--	--	--

Cumulative Table of Well Data and Analytical Results

Vertical Measurements are in feet.

Analytical results are in parts per billion (ppb)

DATE	Well Head Elev.	Ground Water Elev.	Depth To Water	Notes	TPH-Gasoline	Benzene	Toluene	Ethyl-Benzene	Xylene	MTBE	TOG
MW-2											
11/03/88	30.59	9.70	20.89	--	<1000	<1.0	<1.0	<1.0	<1.0	--	--
02/02/89	30.59	9.38	21.21	--	--	--	--	--	--	--	--
02/10/89	30.59	--	--	--	<100	<0.2	<0.2	<0.2	<0.4	--	--
04/23/89	30.59	9.77	20.82	--	--	--	--	--	--	--	--
04/24/89	30.59	--	--	--	<50	<0.5	<1.0	<1.0	<1.0	--	<3000
07/28/89	30.59	9.57	21.02	--	<100	<0.2	<1.0	<0.2	<0.5	--	<3000
10/30/89	30.59	9.63	20.96	--	<500	<0.3	<0.3	<0.3	<0.6	--	--
01/09/90	30.59	9.34	21.25	--	<50	<0.3	<0.3	<0.3	<0.6	--	--
04/18/90	30.59	9.06	21.53	--	<50	<0.3	<0.3	<0.3	<0.6	--	--
06/22/90	30.59	9.02	21.57	--	--	--	--	--	--	--	--
08/09/90	30.59	9.04	21.55	--	<50	<0.3	<0.3	<0.3	<0.6	--	--
11/13/90	30.59	9.05	21.54	--	<50	<0.5	0.8	<0.5	0.9	--	--
05/15/91	30.59	9.44	21.15	--	83	<0.5	<0.5	<0.5	<0.5	--	--
08/27/91	30.59	9.32	21.27	--	97	<0.5	<0.5	<0.5	<0.5	--	--
11/15/91	30.59	9.29	21.30	--	<50	0.5	1.5	0.8	3.6	--	--
02/20/92	30.59	9.13	21.43	--	<50	<0.5	<0.5	<0.5	<0.5	--	--
06/15/92	30.59	9.41	21.18	--	<50	<0.5	<0.5	<0.5	<0.5	--	--
12/16/92	30.56	9.09	21.47	--	<50	<0.5	<0.5	<0.5	<0.5	--	--
04/07/93	30.56	10.03	20.53	--	66	<0.5	<0.5	<0.5	<1.5	--	--
06/09/93	30.56	10.11	20.45	--	<50	<0.5	<0.5	<0.5	<0.5	--	--
09/10/93	30.56	--	--	--	--	--	--	--	--	--	--
09/27/93	30.56	9.59	20.97	--	--	--	--	--	--	--	--
12/17/93	30.56	9.25	21.31	--	<50	<0.5	<0.5	<0.5	<0.5	--	--
03/10/94	30.56	9.33	21.23	--	<50	<0.5	<0.5	<0.5	<0.5	--	--
06/16/94	30.56	9.35	21.21	--	<50	<0.5	<0.5	<0.5	<0.5	--	--
09/07/94	30.56	9.22	21.34	--	<50	<0.5	<0.5	<0.5	<0.5	--	--
11/30/94	30.56	9.66	20.90	--	<50	<0.5	<0.5	<0.5	<0.5	--	--
03/22/95	30.56	10.22	20.34	--	<50	<0.5	<0.5	<0.5	<0.5	--	--
01/17/98	--	--	--	Abandoned	--	--	--	--	--	--	--

Cumulative Table of Well Data and Analytical Results

Vertical Measurements are in feet.

Analytical results are in parts per billion (ppb)

DATE	Well Head Elev.	Ground Water Elev.	Depth To Water	Notes	TPH-Gasoline	Benzene	Toluene	Ethyl-Benzene	Xylene	MTBE	TOG
MW-3											
11/03/88	30.09	9.55	20.54	--	<1000	<1.0	<1.0	<1.0	<1.0	--	--
02/02/89	30.09	9.24	20.85	--	--	--	--	--	--	--	--
02/10/89	30.09	--	--	--	<100	<0.2	<0.2	<0.2	<0.4	--	--
04/23/89	30.09	9.66	20.43	--	--	--	--	--	--	--	--
04/24/89	30.09	--	--	--	<50	<0.5	<1.0	<1.0	<1.0	--	<3000
07/28/89	30.09	9.45	20.64	--	<100	<0.2	<1.0	<0.2	<0.4	--	<3000
10/30/89	30.09	9.48	20.61	--	<500	<0.3	<0.3	<0.3	<0.6	--	--
01/09/90	30.09	9.21	20.88	--	<50	<0.3	<0.3	<0.3	<0.6	--	--
04/18/90	30.09	8.94	21.15	--	<50	<0.3	<0.3	<0.3	<0.6	--	--
06/22/90	30.09	8.89	21.20	--	--	--	--	--	--	--	--
08/09/90	30.09	8.91	21.18	--	<50	<0.3	<0.3	<0.3	<0.6	--	--
11/13/90	30.09	8.94	21.15	--	51	<0.5	<0.5	<0.5	<0.5	--	--
05/15/91	30.09	9.18	20.91	--	85	<0.5	<0.5	<0.5	<0.5	--	--
08/27/91	30.09	9.20	20.89	*	91	<0.5	<0.5	<0.5	<0.5	--	--
11/15/91	30.09	9.07	21.02	--	<50	<0.5	0.7	<0.5	1.3	--	--
02/20/92	30.09	9.02	21.07	--	<50	<0.5	<0.5	<0.5	0.9	--	--
06/15/92	30.09	9.27	20.82	--	50	<0.5	<0.5	<0.5	<0.5	--	--
12/16/92	30.08	9.07	21.07	--	<50	<0.5	<0.5	<0.5	<0.5	--	--
04/07/93	30.08	9.95	20.13	--	<50	<0.5	<0.5	<0.5	<1.5	--	--
06/09/93	30.08	10.03	20.05	--	<50	<0.5	<0.5	<0.5	<0.5	--	--
09/10/93	30.08	--	--	--	<50	<0.5	<0.5	<0.5	<0.5	--	--
09/27/93	30.08	9.50	20.58	--	--	--	--	--	--	--	--
12/17/93	30.08	9.07	21.01	--	<50	<0.5	<0.5	<0.5	<0.5	--	--
03/10/94	30.08	9.22	20.86	--	<50	<0.5	<0.5	<0.5	1.1	--	--
06/16/94	30.08	9.21	20.87	--	<50	<0.5	<0.5	<0.5	<0.5	--	--
09/07/94	30.08	9.11	20.97	--	<50	<0.5	<0.5	<0.5	<0.5	--	--
11/30/94	30.08	10.45	19.63	--	<50	<0.5	<0.5	<0.5	<0.5	--	--
03/22/95	30.08	10.27	19.81	--	<50	<0.5	<0.5	<0.5	<0.5	--	--
01/17/98	--	--	--	Abandoned	--	--	--	--	--	--	--

* See Table 2 of Additional Analyses.

Cumulative Table of Well Data and Analytical Results

Vertical Measurements are in feet.

Analytical results are in parts per billion (ppb)

DATE	Well Head Elev.	Ground Water Elev.	Depth To Water	Notes	TPH-Gasoline	Benzene	Toluene	Ethyl-Benzene	Xylene	MTBE	TOG
MW-4											
04/23/89	31.17	9.84	21.33	--	--	--	--	--	--	--	--
04/24/89	31.17	--	--	--	<50	<0.5	<1.0	<1.0	<1.0	--	<3000
07/28/89	31.17	9.59	21.58	--	<50	<0.1	<0.5	<0.1	<0.2	--	<3000
10/30/89	31.17	9.63	21.54	--	<500	<0.3	<0.3	<0.3	<0.6	--	--
01/09/90	31.17	9.35	21.82	--	<50	<0.3	<0.3	<0.3	<0.6	--	--
04/18/90	31.17	9.08	22.09	--	<50	<0.3	<0.3	<0.3	<0.6	--	--
06/22/90	31.17	9.05	22.12	--	--	--	--	--	--	--	--
08/09/90	31.17	9.06	22.11	--	<50	<0.3	<0.3	<0.3	<0.6	--	--
11/13/90	31.17	9.07	22.10	--	<50	<0.5	1.0	0.5	1.0	--	--
05/15/91	31.17	9.46	21.71	--	<50	<0.5	<0.5	<0.5	<0.5	--	--
08/27/91	31.17	9.30	21.87	--	<50	<0.5	<0.5	<0.5	<0.5	--	--
11/15/91	31.17	9.37	21.80	--	97	<0.5	0.9	<0.5	1.9	--	--
02/20/92	31.17	9.18	21.99	--	<50	<0.5	<0.5	<0.5	<0.5	--	--
06/15/92	31.17	9.43	21.74	--	<50	<0.5	<0.5	<0.5	<0.5	--	--
12/16/92	31.17	9.12	22.05	--	<50	0.7	0.5	0.5	1.3	--	--
04/07/93	31.17	10.06	21.11	--	<50	<0.5	<0.5	<0.5	<1.5	--	--
06/09/93	31.17	--	--	--	--	--	--	--	--	--	--
09/10/93	31.17	--	--	--	--	--	--	--	--	--	--
09/27/93	31.17	9.63	21.54	--	<50	<0.5	<0.5	<0.5	<0.5	--	--
12/17/93	31.17	9.28	21.89	--	<50	<0.5	<0.5	<0.5	<0.5	--	--
03/10/94	31.17	--	--	--	--	--	--	--	--	--	--
06/16/94	31.17	10.63	20.54	--	--	--	--	--	--	--	--
09/07/94	31.17	9.27	21.90	--	<50	<0.5	<0.5	<0.5	<0.5	--	--
11/30/94	31.17	9.83	21.34	--	<50	<0.5	<0.5	<0.5	<0.5	--	--
03/21/95	31.17	10.55	20.62	--	<50	<0.5	<0.5	<0.5	<0.5	--	--
01/17/98	--	--	--	Abandoned	--	--	--	--	--	--	--

Cumulative Table of Well Data and Analytical Results

Vertical Measurements are in feet.

Analytical results are in parts per billion (ppb)

DATE	Well Head Elev.	Ground Water Elev.	Depth To Water	Notes	TPH-Gasoline	Benzene	Toluene	Ethyl-Benzene	Xylene	MTBE	TOG
MW-5											
04/23/89	30.28	9.66	20.62	--	--	--	--	--	--	--	--
04/24/89	30.28	--	--	--	<50	<0.5	<1.0	<1.0	<1.0	--	<3000
07/28/89	30.28	9.42	20.86	--	<100	<0.2	<1.0	<0.2	<0.4	--	<3000
10/30/89	30.28	9.46	20.82	--	<500	<0.3	<0.3	<0.3	<0.6	--	--
01/09/90	30.28	9.21	21.07	--	<50	<0.3	<0.3	<0.3	<0.6	--	--
04/18/90	30.28	8.93	21.35	--	<50	<0.3	<0.3	<0.3	<0.6	--	--
06/22/90	30.28	8.90	21.38	--	--	--	--	--	--	--	--
08/09/90	30.28	8.92	21.36	--	<50	<0.3	<0.3	<0.3	<0.6	--	--
11/13/90	30.28	8.93	21.35	--	<50	<0.5	1.0	<0.5	1.0	--	--
05/15/91	30.28	8.99	21.29	--	<50	<0.5	<0.5	<0.5	<0.5	--	--
08/27/91	30.28	9.17	21.11	--	94	3.0	5.0	1.5	5.5	--	--
11/15/91	30.28	9.10	21.18	--	<50	0.9	1.7	<0.5	2.2	--	--
02/20/92	30.28	9.03	21.25	--	<50	<0.5	<0.5	<0.5	<0.5	--	--
06/15/92	30.28	9.28	21.00	--	<50	<0.5	<0.5	<0.5	<0.5	--	--
12/16/92	30.28	9.05	21.23	--	<50	<0.5	<0.5	<0.5	<0.5	--	--
04/07/93	30.28	9.97	20.31	--	<50	<0.5	<0.5	<0.5	<1.5	--	--
06/09/93	30.28	--	--	--	--	--	--	--	--	--	--
09/10/93	30.28	--	--	--	--	--	--	--	--	--	--
09/27/93	30.28	9.52	20.76	--	--	--	--	--	--	--	--
01/17/98	--	--	--	Abandoned	--	--	--	--	--	--	--

Cumulative Table of Well Data and Analytical Results

Vertical Measurements are in feet.

Analytical results are in parts per billion (ppb)

DATE	Well Head Elev.	Ground Water Elev.	Depth To Water	Notes	TPH-Gasoline	Benzene	Toluene	Ethyl-Benzene	Xylene	MTBE	TOG
MW-6											
04/23/89	29.46	9.41	20.05	--	--	--	--	--	--	--	--
04/24/89	29.46	--	--	--	<50	<0.5	<1.0	<1.0	<1.0	--	<3.0
07/28/89	29.46	9.16	20.30	--	<100	<0.2	<1.0	<0.2	<0.4	--	<3.0
10/30/89	29.46	9.14	20.32	--	<500	<0.3	<0.3	<0.3	<0.6	--	--
01/09/90	29.46	8.95	20.51	--	<50	<0.3	<0.3	<0.3	<0.6	--	--
04/18/90	29.46	8.74	20.72	--	<50	<0.3	<0.3	<0.3	<0.6	--	--
06/22/90	29.46	8.69	20.77	--	--	--	--	--	--	--	--
08/09/90	29.46	8.72	20.74	--	<50	<0.3	<0.3	<0.3	<0.6	--	--
11/13/90	29.46	8.71	20.75	--	<50	3.0	5.0	0.5	2.0	--	--
05/15/91	29.46	8.85	20.61	--	<50	<0.5	<0.5	<0.5	<0.5	--	--
08/27/91	29.46	8.93	20.53	--	180	6.1	12	3.8	14	--	--
11/15/91	29.46	8.93	20.53	--	<50	<0.5	0.6	<0.5	<0.5	--	--
02/20/92	29.46	8.77	20.69	--	<50	0.9	1.1	<0.5	1.4	--	--
06/15/92	29.46	9.08	20.38	--	<50	<0.5	<0.5	<0.5	<0.5	--	--
12/16/92	29.45	8.88	20.57	--	<50	<0.5	<0.5	<0.5	<0.5	--	--
04/07/93	29.45	9.86	19.59	--	<50	<0.5	<0.5	<0.5	<1.5	--	--
06/09/93	29.45	9.95	19.50	--	<50	<0.5	<0.5	<0.5	<0.5	--	--
09/10/93	29.45	--	--	--	--	--	--	--	--	--	--
09/27/93	29.45	9.38	20.07	--	--	--	--	--	--	--	--
01/17/98	--	--	--	Abandoned	--	--	--	--	--	--	--

Cumulative Table of Well Data and Analytical Results

Vertical Measurements are in feet.

Analytical results are in parts per billion (ppb)

DATE	Well Head Elev.	Ground Water Elev.	Depth To Water	Notes	TPH-Gasoline	Benzene	Toluene	Ethyl-Benzene	Xylene	MTBE	TOG
MW-7											
04/23/89	29.01	10.02	18.99	--	--	--	--	--	--	--	--
04/24/89	29.01	--	--	See Table 2	8400	100	260	160	1300	--	<3.0
07/28/89	29.01	9.07	19.94	--	7000	230	90	70	440	--	<3000
07/28/89	29.01	--	--	Duplicate	6000	280	180	58	430	--	--
10/30/89	29.01	9.04	19.97	--	10,000	570	55	160	400	--	--
10/30/89	29.01	--	--	Duplicate	9900	520	82	180	410	--	--
01/09/90	29.01	8.86	20.15	--	3400	290	72	9.0	200	--	--
04/18/90	29.01	8.64	20.37	--	6800	350	140	110	400	--	--
06/22/90	29.01	8.61	20.40	--	--	--	--	--	--	--	--
08/09/90	29.01	8.63	20.38	--	11,000	360	130	14	660	--	--
11/13/90	29.01	8.60	20.41	--	6500	230	110	97	460	--	--
05/15/91	29.01	8.54	20.47	--	4600	180	55	46	300	--	--
08/27/91	29.01	8.87	20.14	--	7000	220	53	63	340	--	--
11/15/91	29.01	8.79	20.22	--	3300	150	19	4.9	200	--	--
02/20/92	29.01	8.69	20.32	--	5200	520	150	100	380	--	--
06/15/92	29.01	9.03	19.98	--	10,000	760	430	320	1100	--	--
12/16/92	29.01	8.87	20.14	--	11,000	810	350	280	1100	--	--
04/07/93	29.01	9.87	19.14	--	150	1.4	0.9	0.9	4.5	--	--
06/09/93	29.01	9.96	19.05	--	180	4.0	1.0	1.0	3.0	--	--
09/10/93	29.01	--	--	--	--	--	--	--	--	--	--
09/27/93	29.01	--	--	--	--	--	--	--	--	--	--
12/17/93	29.01	--	--	--	--	--	--	--	--	--	--
03/10/94	29.01	--	--	--	--	--	--	--	--	--	--
06/16/94	29.01	--	--	--	--	--	--	--	--	--	--
09/07/94	29.01	--	--	--	--	--	--	--	--	--	--
11/30/94	29.01	--	--	Inaccessible	--	--	--	--	--	--	--
01/17/95	29.01	17.39	11.62	--	2700	140	65	44	200	--	--
03/22/95	29.01	11.33	17.68	--	160	3.4	<0.5	1.1	0.77	--	--
06/27/95	29.01	9.75	19.26	--	<50	<0.5	<0.5	<0.5	<0.5	--	--
09/28/95	29.01	9.67	19.34	--	1500	84	24	26	130	--	--
12/30/95	29.01	9.85	19.16	--	200	1.6	<0.5	1.3	5.9	5.5	--
02/28/96	29.01	10.57	18.44	--	650	14	1.3	4.2	16	34	--
06/27/96	29.01	10.29	18.72	--	640	140	10	9.8	14	55	--
09/13/96	29.01	9.61	19.40	--	1400	100	30	24	66	130	--
12/16/96	29.01	8.91	20.10	--	2600	140	72	51	180	<50	--

CONTINUED ON NEXT PAGE

Cumulative Table of Well Data and Analytical Results

Vertical Measurements are in feet.

Analytical results are in parts per billion (ppb)

DATE	Well Head Elev.	Ground Water Elev.	Depth To Water	Notes	TPH-Gasoline	Benzene	Toluene	Ethyl-Benzene	Xylene	MTBE	TOG
MW-7 (CONT'D)											
03/20/97	29.01	10.06	18.95	--	64	1.7	2.4	<0.5	0.67	<2.5	--
09/08/97	29.01	9.34	19.67	--	590	45	<1.0	7.7	<1.0	46	--
02/16/98	29.01	10.41	18.60	--	120	8.7	7.5	1.9	11	4.4	--
08/25/98	29.01	9.61	19.40	--	160	6.2	33	0.84	2.0	<2.5	--
03/09/99	29.01	13.01	16.00	--	<50	<0.5	<0.5	<0.5	<0.5	<2.5	--
09/29/99	29.01	12.12	16.89	--	276	35.1	2.54	2.17	5.43	<5.0	--
09/29/99	29.01	12.12	16.89	Confirmation run	--	--	--	--	--	<2.0	--
03/27/00	29.01	9.42	19.59	--	721	38.5	1.06	6.31	9.38	7.75	--
MW-8											
04/23/89	29.57	9.43	20.14	--	--	--	--	--	--	--	--
04/24/89	29.57	--	--	--	<50	<0.5	<1.0	<1.0	<1.0	--	3000
04/24/89	29.57	--	--	Duplicate	<50	<0.5	<1.0	<1.0	<1.0	--	--
07/28/89	29.57	9.20	20.37	--	<100	<0.2	<1.0	<0.2	<0.4	--	<3000
10/30/89	29.57	9.25	20.32	--	<500	<0.3	<0.3	<0.3	<0.6	--	--
01/09/90	29.57	8.97	20.60	--	<50	<0.3	<0.3	<0.3	<0.6	--	--
04/18/90	29.57	8.70	20.87	--	<50	<0.3	<0.3	<0.3	<0.6	--	--
06/22/90	29.57	9.23	20.34	--	--	--	--	--	--	--	--
08/09/90	29.57	8.68	20.89	--	<50	<0.3	<0.3	<0.3	<0.6	--	--
11/13/90	29.57	8.71	20.86	--	<50	<0.5	0.8	<0.5	2.0	--	--
05/15/91	29.57	9.08	20.49	--	<50	<0.5	<0.5	<0.5	<0.5	--	--
08/27/91	29.57	8.97	20.60	--	73	<0.5	<0.5	<0.5	<0.5	--	--
11/15/91	29.57	8.95	20.62	--	<50	<0.5	0.7	<0.5	2.1	--	--
02/20/92	29.57	8.77	20.80	--	<50	<0.5	<0.5	<0.5	<0.5	--	--
06/15/92	29.57	9.09	20.48	--	<50	<0.5	<0.5	<0.5	<0.5	--	--
12/16/92	29.57	8.89	20.68	--	<50	<0.5	<0.5	<0.5	<0.5	--	--
04/07/93	29.57	9.87	19.70	--	<50	<0.5	<0.5	<0.5	<1.5	--	--
06/09/93	29.57	9.97	19.60	--	<50	<0.5	<0.5	<0.5	<0.5	--	--
09/10/93	29.57	--	--	--	--	--	--	--	--	--	--
09/27/93	29.57	9.35	20.22	--	--	--	--	--	--	--	--
01/17/98	--	--	--	Abandoned	--	--	--	--	--	--	--

Cumulative Table of Well Data and Analytical Results

Vertical Measurements are in feet.

Analytical results are in parts per billion (ppb)

DATE	Well Head Elev.	Ground Water Elev.	Depth To Water	Notes	TPH-Gasoline	Benzene	Toluene	Ethyl-Benzene	Xylene	MTBE	TOG
MW-9											
06/22/90	28.67	7.87	20.80	--	5700	47	31	280	530	--	<1000
08/09/90	28.67	7.93	20.74	--	8000	<0.3	17	210	480	--	--
11/13/90	28.67	7.89	20.78	--	6400	<3.0	20	240	450	--	--
05/15/91	28.67	8.19	20.48	--	5700	2.0	16	190	390	--	--
08/27/91	28.67	8.12	20.55	--	6700	<3.0	31	180	350	--	--
11/15/91	28.67	8.10	20.57	--	4000	8.8	26	150	280	--	--
02/20/92	28.67	6.90	21.77	--	3400	13	30	230	460	--	--
06/15/92	28.67	8.30	20.37	--	4500	19	72	280	560	--	--
12/16/92	28.68	8.39	20.29	--	9900	380	220	380	1300	--	--
04/07/93	28.68	9.36	19.32	--	8700	51	150	360	1000	--	--
06/09/93	28.68	9.52	19.16	--	8900	170	160	350	1100	--	--
09/10/93	28.68	--	--	--	4600	110	63	190	350	--	--
09/27/93	28.68	8.74	19.94	--	--	--	--	--	--	--	--
12/17/93	28.68	8.37	20.31	--	4600	92	85	180	300	--	--
03/10/94	28.68	8.38	20.30	--	3300	8.0	29	120	170	--	--
06/16/94	28.68	8.42	20.26	--	2900	4.8	16	85	64	--	--
09/07/94	28.68	8.27	20.41	--	2900	<0.5	9.9	70	75	--	--
11/30/94	28.68	8.70	19.98	--	2100	<5.0	<5.0	53	51	--	--
03/22/95	28.68	9.27	19.41	--	2200	<5.0	5.3	26	69	--	--
06/27/95	28.68	9.28	19.40	--	2900	7.4	10	68	99	--	--
09/28/95	28.68	9.13	19.55	--	4000	32	<10	36	44	--	--
12/30/95	28.68	8.88	19.80	--	3800	<5.0	13	<5.0	120	120	--
02/28/96	28.68	8.93	19.75	--	2000	9.9	<5.0	46	30	<25	--
06/27/96	28.68	9.13	19.55	--	2400	36	7.1	65	72	<50	--
09/13/96	28.68	8.86	19.82	--	2500	26	8.4	53	39	36	--
12/16/96	28.68	7.91	20.77	--	1200	3.5	2.4	12	14	<10	--
03/20/97	28.68	9.28	19.40	--	2400	25	5.8	26	22	<25	--
09/08/97	28.68	8.59	20.09	--	1800	9.5	8.1	22	21	12	--
02/16/98	28.68	9.45	19.23	--	950	5.6	3.1	13	13	18	--
08/25/98	28.68	9.18	19.50	--	2100	2.5	6.4	35	51	8.9	--
03/09/99	28.68	8.87	19.81	--	1400	12	7.8	8.8	16	8.8	--
07/19/99	28.68	--	--	*	--	--	--	--	--	--	--
09/29/99	28.68	8.27	20.41	--	217	1.36	1.14	1.56	1.49	<5.0	--
09/29/99	28.68	8.27	20.41	Confirmation run	--	--	--	--	--	<2.0	--
03/27/00	28.68	--	--	Inaccessible	--	--	--	--	--	--	--

* ORC's installed.

Cumulative Table of Well Data and Analytical Results

Vertical Measurements are in feet.

Analytical results are in parts per billion (ppb)

DATE	Well Head Elev.	Ground Water Elev.	Depth To Water	Notes	TPH-Gasoline	Benzene	Toluene	Ethyl-Benzene	Xylene	MTBE	TOG
MW-10											
06/22/90	28.60	8.12	20.48	--	<50	<0.5	<0.5	<0.5	<0.5	--	<1000
08/09/90	28.60	8.15	20.45	--	<50	<0.3	<0.3	<0.3	<0.6	--	--
11/13/90	28.60	8.13	20.47	--	<50	<0.5	2.0	0.5	2.0	--	--
05/15/91	28.60	8.45	20.15	--	<50	<0.5	<0.5	<0.5	<0.5	--	--
08/27/91	28.60	8.33	20.27	--	<50	<0.5	<0.5	<0.5	<0.5	--	--
11/15/91	28.60	8.27	20.33	--	<50	<0.5	<0.5	<0.5	<0.5	--	--
02/20/92	28.60	7.15	21.45	--	<50	2.0	2.2	<0.5	2.1	--	--
06/15/92	28.60	7.30	21.30	--	<50	<0.5	<0.5	<0.5	<0.5	--	--
12/16/92	28.62	8.45	20.17	--	<50	<0.5	<0.5	<0.5	<0.5	--	--
04/07/93	28.62	9.41	19.26	--	<50	<0.5	<0.5	<0.5	<1.5	--	--
06/09/93	28.62	9.55	19.07	--	<50	<0.5	<0.5	<0.5	<0.5	--	--
09/10/93	28.62	--	--	--	<50	<0.5	<0.5	<0.5	<0.5	--	--
09/24/93	28.62	8.90	19.72	--	--	--	--	--	--	--	--
12/17/93	28.62	8.55	20.07	--	<50	<0.5	<0.5	<0.5	<0.5	--	--
03/10/94	28.62	8.65	19.97	--	<50	<0.5	<0.5	<0.5	<0.5	--	--
06/16/94	28.62	8.64	19.98	--	<50	<0.5	<0.5	<0.5	<0.5	--	--
09/07/94	28.62	8.50	20.12	--	<50	<0.5	<0.5	<0.5	<0.5	--	--
11/30/94	28.62	8.92	19.70	--	<50	<0.5	<0.5	<0.5	<0.5	--	--
03/22/95	28.62	9.70	18.92	--	<50	<0.5	<0.5	<0.5	<0.5	--	--
01/17/98	--	--	--	Abandoned	--	--	--	--	--	--	--

Cumulative Table of Well Data and Analytical Results

Vertical Measurements are in feet.

Analytical results are in parts per billion (ppb)

DATE	Well Head Elev.	Ground Water Elev.	Depth To Water	Notes	TPH-Gasoline	Benzene	Toluene	Ethyl-Benzene	Xylene	MTBE	TOG
MW-13											
11/15/91	28.63	7.56	21.07	*	3100	68	40	110	270	--	--
02/20/92	28.63	6.46	22.17	--	3100	120	50	240	400	--	--
06/15/92	28.63	7.96	20.67	--	3200	35	33	210	300	--	--
12/16/92	28.62	8.28	20.34	--	87,000	1400	540	2400	11,000	--	--
04/07/93	28.62	9.21	19.41	--	1500	72	12	70	160	--	--
06/09/93	28.62	9.42	19.20	--	210	6.0	2.0	7.0	16	--	--
09/10/93	28.62	--	--	--	73	3.0	<0.5	2.0	3.0	--	--
09/27/93	28.62	8.27	20.35	--	--	--	--	--	--	--	--
12/17/93	28.62	7.86	20.76	--	640	43	12	12	37	--	--
03/10/94	28.62	7.93	20.69	--	540	44	22	10	69	--	--
06/16/94	28.62	7.95	20.67	--	1800	63	12	18	64	--	--
09/07/94	28.62	7.79	20.83	--	1400	59	12	22	50	--	--
11/30/94	28.62	8.21	20.41	--	700	36	4.4	18	31	--	--
03/22/95	28.62	8.80	19.82	--	190	1.4	1.4	<0.5	<0.5	--	--
06/27/95	28.62	8.86	19.76	--	220	1.8	<0.5	<0.5	0.84	--	--
09/28/95	28.62	8.58	20.04	--	160	3.2	<0.5	0.97	2.2	--	--
12/30/95	28.62	8.32	20.30	--	190	0.94	<0.5	0.74	1.1	<2.5	--
02/28/96	28.62	8.73	19.89	--	130	<0.5	<0.5	<0.5	<0.5	<2.5	--
06/27/96	28.62	8.64	19.98	--	280	<0.5	1.4	<0.5	3.8	9.4	--
09/13/96	28.62	8.34	20.28	--	170	<0.5	<0.5	<0.5	0.89	2.7	--
12/16/96	28.62	8.15	20.47	--	170	<0.5	0.51	0.6	3.0	<2.5	--
03/20/97	28.62	8.72	19.90	--	290	1.6	0.78	1.1	1.5	3.4	--
09/08/97	28.62	8.13	20.49	--	140	0.52	1.5	<0.5	1.2	<2.5	--
02/16/98	28.62	8.87	19.75	--	64	<0.5	<0.5	<0.5	<0.5	<2.5	--
08/25/98	28.62	8.60	20.02	--	99	<0.5	<0.5	<0.5	1.7	<2.5	--
03/09/99	28.62	8.62	20.00	--	<50	<0.5	<0.5	<0.5	<0.5	<2.5	--
09/29/99	28.62	8.13	20.49	--	<50	<0.5	<0.5	<0.5	<0.5	<5.0	--
09/29/99	28.62	8.13	20.49	Confirmation run	--	--	--	--	--	<2.0	--
03/27/00	28.62	8.58	20.04	--	89.5	0.765	0.682	<0.5	0.688	4.04	--

*See Table 2 of Additional Analysis.

Cumulative Table of Well Data and Analytical Results

Vertical Measurements are in feet.

Analytical results are in parts per billion (ppb)

DATE	Well Head Elev.	Ground Water Elev.	Depth To Water	Notes	TPH-Gasoline	Benzene	Toluene	Ethyl-Benzene	Xylene	MTBE	TOG
MW-14											
11/15/91	29.46	9.13	20.33	--	<50	<0.5	<0.5	<0.5	<0.5	--	--
02/20/92	29.46	8.05	21.41	--	<50	1.3	1.8	1.1	5.2	--	--
06/15/92	29.46	--	--	--	--	--	--	--	--	--	--
12/16/92	29.45	8.79	20.66	--	<50	<0.5	<0.5	<0.5	<0.5	--	--
04/07/93	29.45	--	--	--	--	--	--	--	--	--	--
06/09/93	29.45	--	--	--	--	--	--	--	--	--	--
09/10/93	29.45	--	--	--	--	--	--	--	--	--	--
09/27/93	29.45	9.19	20.26	--	--	--	--	--	--	--	--
01/17/98	--	--	--	Abandoned	--	--	--	--	--	--	--
MW-15											
12/16/92	28.04	8.30	19.74	--	<50	<0.5	<0.5	<0.5	<0.5	--	--
04/07/93	28.04	9.24	18.80	--	<50	1.3	<0.5	<0.5	<1.5	--	--
06/09/93	28.04	9.44	18.60	--	<50	<0.5	<0.5	<0.5	<0.5	--	--
09/10/93	28.04	--	--	--	--	--	--	--	--	--	--
09/27/93	28.04	8.11	19.93	--	<50	2.0	<0.5	<0.5	<0.5	--	--
12/17/93	28.04	7.72	20.32	--	<50	<0.5	<0.5	<0.5	<0.5	--	--
03/10/94	28.04	7.75	20.29	--	<50	<0.5	<0.5	<0.5	<0.5	--	--
06/16/94	28.04	7.73	20.31	--	<50	<0.5	<0.5	<0.5	<0.5	--	--
09/07/94	28.04	7.61	20.43	--	<50	<0.5	<0.5	<0.5	<0.5	--	--
11/30/94	28.04	8.03	20.01	--	<50	<0.5	<0.5	<0.5	<0.5	--	--
03/22/95	28.04	8.57	19.47	--	69	4.9	<0.5	<0.5	<0.5	--	--
06/27/95	28.04	8.70	19.34	--	<50	3.9	<0.5	1.4	<0.5	--	--
09/28/95	28.04	8.38	19.66	--	<50	0.82	<0.5	<0.5	<0.5	--	--
12/30/95	28.04	8.10	19.94	--	160	7.0	1.4	<0.5	1.8	14	--
02/28/96	28.04	8.41	19.63	--	81	1.7	<0.5	<0.5	<0.5	<2.5	--
06/27/96	28.04	8.44	19.60	--	<50	<0.5	<0.5	<0.5	<0.5	<5.0	--
09/13/96	28.04	8.14	19.90	--	<50	<0.5	<0.5	<0.5	<0.5	<2.5	--
12/16/96	28.04	7.81	20.23	--	<50	<0.5	<0.5	<0.5	<0.5	<2.5	--
03/20/97	28.04	8.52	19.52	--	<50	<0.5	<0.5	<0.5	<0.5	<2.5	--
09/08/97	28.04	7.86	20.18	--	<50	<0.5	<0.5	<0.5	<0.5	<2.5	--
02/16/98	28.04	8.67	19.37	--	<50	<0.5	<0.5	<0.5	<0.5	<2.5	--
08/25/98	28.04	8.34	19.70	--	<50	<0.5	<0.5	<0.5	<0.5	<2.5	--
03/09/99	28.04	8.35	19.69	--	<50	<0.5	<0.5	<0.5	<0.5	<2.5	--
09/29/99	28.04	7.92	20.12	--	<50	<0.5	<0.5	<0.5	<0.5	<5.0	--
03/27/00	28.04	8.37	19.67	--	<50	<0.5	<0.5	<0.5	<0.5	<2.5	--

Cumulative Table of Well Data and Analytical Results

Vertical Measurements are in feet.

Analytical results are in parts per billion (ppb)

DATE	Well Head Elev.	Ground Water Elev.	Depth To Water	Notes	TPH-Gasoline	Benzene	Toluene	Ethyl-Benzene	Xylene	MTBE	TOG
MW-16											
12/16/92	28.32	8.74	19.58	--	--	--	--	--	--	--	--
12/21/92	28.32	--	--	--	<50	<0.5	<0.5	<0.5	<0.5	--	--
04/07/93	28.32	9.91	18.41	--	<50	<0.5	6.8	<0.5	<0.5	--	--
06/09/93	28.32	10.07	18.25	--	<50	<0.5	<0.5	<0.5	<0.5	--	--
09/10/93	28.32	--	--	--	<50	<0.5	<0.5	<0.5	<0.5	--	--
09/27/93	28.32	8.16	20.16	--	--	--	--	--	--	--	--
12/17/93	28.32	--	--	--	--	--	--	--	--	--	--
03/10/94	28.32	7.77	20.55	--	<50	<0.5	<0.5	<0.5	<0.5	--	--
06/16/94	28.32	7.67	20.65	--	<50	0.9	0.7	<0.5	<0.5	--	--
09/07/94	28.32	7.59	20.73	--	150	1.3	0.8	1.2	3.6	--	--
11/30/94	28.32	8.04	20.28	--	4200	300	<5.0	34	350	--	--
03/22/95	28.32	8.65	19.67	--	2900	180	5.7	21	91	--	--
06/27/95	28.32	8.72	19.60	--	2000	330	10	27	48	--	--
09/28/95	28.32	--	--	Inaccessible	--	--	--	--	--	--	--
12/30/95	28.32	8.06	20.26	--	3100	770	39	30	80	<12	--
02/28/96	28.32	8.48	19.84	--	1600	320	15	11	21	<25	--
06/27/96	28.32	8.45	19.87	--	2900	670	48	54	86	280	--
09/13/96	28.32	8.17	20.15	--	1400	18	4.0	8.6	16	<10	--
12/16/96	28.32	7.53	20.79	--	3100	500	25	23	52	<25	--
03/20/97	28.32	8.52	19.80	--	3800	550	23	14	8.4	140	--
09/08/97	28.32	7.97	20.35	--	2800	470	28	24	41	<10	--
02/16/98	28.32	8.40	19.92	--	3100	570	35	27	54	<25	--
08/25/98	28.32	8.12	20.20	--	3500	520	43	57	75	<12	--
03/09/99	28.32	8.15	20.17	--	4900	750	55	40	120	<50	--
09/29/99	28.32	7.77	20.55	--	5480	717	45.3	44	100	<125	--
09/29/99	28.32	7.77	20.55	Confirmation run	--	--	--	--	--	<10	--
03/27/00	28.32	--	--	Inaccessible	--	--	--	--	--	--	--

Cumulative Table of Well Data and Analytical Results

Vertical Measurements are in feet.

Analytical results are in parts per billion (ppb)

DATE	Well Head Elev.	Ground Water Elev.	Depth To Water	Notes	TPH-Gasoline	Benzene	Toluene	Ethyl-Benzene	Xylene	MTBE	TOG
TRIP BLANK											
11/03/88	--	--	--	--	--	<1.0	<1.0	<1.0	<1.0	--	--
02/10/89	--	--	--	--	<50	<0.1	<0.1	<0.1	<0.2	--	--
04/24/89	--	--	--	--	<50	<0.5	<0.5	<1.0	<1.0	--	--
07/28/89	--	--	--	--	<50	<0.1	<0.1	<0.1	<0.2	--	--
10/30/89	--	--	--	--	<500	<0.3	<0.3	<0.3	<0.6	--	--
01/09/90	--	--	--	--	<50	<0.3	<0.3	<0.3	<0.6	--	--
04/18/90	--	--	--	--	<50	<0.3	<0.3	<0.3	<0.6	--	--
06/22/90	--	--	--	--	<50	<0.5	<0.5	<0.5	<0.5	--	--
08/09/90	--	--	--	--	<50	<0.3	<0.3	<0.3	<0.6	--	--
11/13/90	--	--	--	--	<50	<0.5	<0.5	<0.5	<0.5	--	--
05/15/91	--	--	--	--	<50	<0.5	<0.5	<0.5	<0.5	--	--
08/27/91	--	--	--	--	<50	<0.5	<0.5	<0.5	<0.5	--	--
11/15/91	--	--	--	--	<50	<0.5	<0.5	<0.5	<0.5	--	--
02/20/92	--	--	--	--	<50	<0.5	<0.5	<0.5	<0.5	--	--
06/15/92	--	--	--	--	<50	<0.5	<0.5	<0.5	<0.5	--	--
12/16/92	--	--	--	--	<50	<0.5	<0.5	<0.5	<0.5	--	--
04/07/93	--	--	--	--	<50	<0.5	<0.5	<0.5	<1.5	--	--
06/09/93	--	--	--	--	<50	<0.5	<0.5	<0.5	<0.5	--	--
09/10/93	--	--	--	--	<50	<0.5	<0.5	<0.5	<0.5	--	--
09/27/93	--	--	--	--	<50	<0.5	<0.5	<0.5	<0.5	--	--
12/17/93	--	--	--	--	<50	<0.5	<0.5	<0.5	<0.5	--	--
03/10/94	--	--	--	--	<50	<0.5	0.6	<0.5	0.6	--	--
06/16/94	--	--	--	--	<50	<0.5	<0.5	<0.5	<0.5	--	--
09/07/94	--	--	--	--	<50	<0.5	<0.5	<0.5	<0.5	--	--
11/30/94	--	--	--	--	<50	<0.5	<0.5	<0.5	<0.5	--	--
01/17/95	--	--	--	--	<50	<0.5	<0.5	<0.5	<0.5	--	--
03/22/95	--	--	--	--	<50	<0.5	<0.5	<0.5	<0.5	--	--
06/27/95	--	--	--	--	<50	<0.5	<0.5	<0.5	<0.5	--	--
09/28/95	--	--	--	--	<50	<0.5	<0.5	<0.5	<0.5	--	--
12/30/95	--	--	--	--	<50	<0.5	<0.5	<0.5	<0.5	--	--
02/28/96	--	--	--	--	<50	<0.5	<0.5	<0.5	<0.5	<2.5	--
06/27/96	--	--	--	--	<50	<0.5	<0.5	<0.5	<0.5	<5.0	--
09/13/96	--	--	--	--	<50	<0.5	<0.5	<0.5	<0.5	--	--
12/16/96	--	--	--	--	<50	<0.5	<0.5	<0.5	<0.5	<2.5	--

CONTINUED ON NEXT PAGE

Cumulative Table of Well Data and Analytical Results

Vertical Measurements are in feet.

Analytical results are in parts per billion (ppb)

DATE	Well Head Elev.	Ground Water Elev.	Depth To Water	Notes	TPH-Gasoline	Benzene	Toluene	Ethyl-Benzene	Xylene	MTBE	TOG
TRIP BLANK (CONT'D)											
03/20/97	--	--	--	--	<50	<0.5	<0.5	<0.5	<0.5	<2.5	--
09/08/97	--	--	--	--	<50	<0.5	<0.5	<0.5	<0.5	<2.5	--
02/16/98	--	--	--	--	<50	<0.5	<0.5	<0.5	<0.5	<2.5	--
08/25/98	--	--	--	--	<50	<0.5	<0.5	<0.5	<0.5	<2.5	--
03/09/99	--	--	--	--	<50	<0.5	<0.5	<0.5	<0.5	<2.5	--
09/29/99	--	--	--	--	<50	<0.5	<0.5	<0.5	<0.5	<5.0	--
03/27/00	--	--	--	--	<50	<0.5	<0.5	<0.5	<0.5	<2.5	--

Cumulative Table of Well Data and Analytical Results

ADDITIONAL ANALYSES

Vertical Measurements are in feet.

Analytical values are in parts per billion (ppb)

DATE	Carbon Tet	Chloro-form	PCE	TCE	1, 2,-DCE	t-1, 2-DCE	c-1, 2-DCE	1, 1, 1-TCA	1,2-DCA	1, 2-DCP	1, 2-DCP
MW-1											
11/03/88	18	7.0	<1.0	<1.0	--	<1.0	--	<1.0	<1.0	--	--
02/10/89	17	6.0	<0.2	<0.2	--	<0.2	<0.2	<0.2	<0.2	--	--
04/24/89	16	6.0	<1.0	<1.0	<1.0	--	--	<1.0	<1.0	--	--
07/28/89	20	6.4	<0.1	<0.1	--	<0.1	<0.1	0.3	<0.1	--	--
10/30/89	11	4.9	<0.5	<0.5	<0.5	--	--	<0.5	<0.5	--	--
01/09/90	24	7.2	<0.5	<0.5	<0.5	--	--	<0.5	<0.5	--	--
04/18/90	23	5.5	<0.5	<0.5	<0.5	--	--	1.4	<0.5	<0.5	<0.5
08/09/90	32	11	0.7	<0.5	<0.5	--	--	<0.5	<0.5	<0.5	<0.5
11/13/90	24	7.0	60.7	<0.5	--	<0.5	<0.5	<0.5	<0.5	<0.5	<0.5
05/15/91	15	5.0	<0.5	<0.5	--	<0.5	<0.5	<0.5	<0.5	<0.5	<0.5
08/27/91	18	4.2	<0.5	<0.5	--	--	<0.5	<0.5	<0.5	<0.5	<0.5
11/15/91	21	7.9	<0.5	<0.5	--	<0.5	<0.5	<0.5	<0.5	<0.5	<0.5
02/20/92	24	7.5	<0.5	<0.5	--	<0.5	<0.5	<0.5	<0.5	<0.5	<0.5
06/15/92	10	3.2	<0.5	<0.5	--	<0.5	<0.5	<0.5	<0.5	<0.5	<0.5

Cumulative Table of Well Data and Analytical Results

ADDITIONAL ANALYSES

Vertical Measurements are in feet.

Analytical values are in parts per billion (ppb)

DATE	Carbon Tet	Chloro-form	PCE	TCE	1, 2,-DCE	t-1, 2-DCE	c-1, 2-DCE	1, 1, 1-TCA	1,2-DCA	1, 2-DCP	1, 2-DCP
MW-2											
11/03/88	3.0	2.0	34	3.0	--	10	--	<1.0	<1.0	--	--
02/10/89	1.4	1.0	17.2	<0.2	--	<0.2	6.3	<0.2	<0.2	--	--
04/24/89	2.0	2.0	38	3.0	9.0	--	--	<1.0	<1.0	--	--
07/28/89	3.7	2.0	46	2.6	--	<0.2	<0.2	<0.2	<0.2	--	--
10/30/89	1.4	2.6	53	1.1	14	--	--	<0.5	<0.5	--	--
01/09/90	3.6	3.9	78	5.3	16	--	--	<0.5	<0.5	--	--
04/18/90	1.5	2.7	130	3.9	19	--	--	<0.5	<0.5	<0.5	<0.5
08/09/90	2.1	2.1	74	6.1	15	--	--	<0.5	<0.5	<0.5	<0.5
11/13/90	<0.5	2.0	40	4.0	--	<0.5	10	<0.5	<0.5	<0.5	<0.5
05/15/91	2.0	2.0	56	6.0	--	<0.5	15	<0.5	<0.5	<0.5	<0.5
08/27/91	1.1	0.9	46	3.9	--	--	8.0	<0.5	<0.5	<0.5	<0.5
11/15/91	0.6	1.1	58	3.1	--	<0.5	6.3	<0.5	<0.5	<0.5	<0.5
02/20/92	11	<2.5	62	3.1	--	<2.5	4.3	<2.5	<2.5	<2.5	<2.5
06/15/92	<0.5	1.2	45	3.1	--	<0.5	4.8	<0.5	<0.5	<0.5	<0.5
MW-3											
11/03/88	8.0	6.0	84	3.0	--	5.0	--	<1.0	<1.0	--	--
02/10/89	5.8	4.0	53	1.9	--	<0.2	9.0	<0.2	<0.2	--	--
04/24/89	7.0	6.0	110	3.0	11	--	--	<1.0	<1.0	--	--
07/28/89	8.6	5.0	49	2.1	--	<0.2	11	<0.2	<0.1	--	--
10/30/89	5.6	5.3	62	0.7	8.2	--	--	<0.5	<0.5	--	--
01/09/90	8.6	6.1	81	73.8	8.7	--	--	<0.5	<0.5	--	--
04/18/90	7.6	5.8	120	2.4	11	--	--	<0.5	<0.5	<0.5	<0.5
08/09/90	11	6.7	81	5.1	11	--	--	<0.5	<0.5	<0.5	<0.5
11/13/90	7.0	5.0	43	4.0	--	<0.5	9.0	<0.5	<0.5	<0.5	<0.5
05/15/91	6.0	4.0	46	3.0	--	<0.5	8.0	<0.5	<0.5	<0.5	<0.5
08/27/91	5.5	3.8	43	2.6	--	--	8.1	<0.5	<0.5	<0.5	<0.5
11/15/91	6.3	5.0	67	3.4	--	0.8	7.4	0.9	<0.5	<0.5	<0.5
02/20/92	2.8	4.0	96	3.0	--	<2.5	6.1	<2.5	<2.5	<2.5	<2.5
06/15/92	5.0	3.9	86	2.9	--	<0.5	7.5	<0.5	<0.5	<0.5	<0.5

Cumulative Table of Well Data and Analytical Results

ADDITIONAL ANALYSES

Vertical Measurements are in feet.

Analytical values are in parts per billion (ppb)

DATE	Carbon Tet	Chloro-form	PCE	TCE	1, 2-DCE	t-1, 2-DCE	c-1, 2-DCE	1, 1, 1-TCA	1,2-DCA	1, 2-DCP	1, 2-DCP
MW-4											
04/24/89	35	11	<1.0	<1.0	<1.0	--	--	<1.0	<1.0	--	--
07/28/89	32	9.3	<0.1	<0.1	--	<0.1	<0.1	<0.1	<0.1	--	--
10/30/89	32	8.5	<0.5	<0.5	<0.5	--	--	<0.5	<0.5	--	--
01/09/90	36	9.8	<0.5	<0.5	<0.5	--	--	<0.5	<0.5	--	--
04/18/90	41	9.5	<0.5	<0.5	<0.5	--	--	<0.5	<0.5	<0.5	<0.5
08/09/90	38	11	<0.5	<0.5	<0.5	--	--	<0.5	<0.5	<0.5	<0.5
11/13/90	40	11	<0.5	<0.5	--	<0.5	<0.5	<0.5	<0.5	<0.5	<0.5
05/15/91	35	10	<0.5	<0.5	--	<0.5	<0.5	<0.5	<0.5	<0.5	<0.5
08/27/91	28	6.1	<0.5	<0.5	--	--	<0.5	<0.5	<0.5	<0.5	<0.5
11/15/91	23	9.1	<0.5	<0.5	--	<0.5	<0.5	<0.5	<0.5	<0.5	<0.5
02/20/92	400	140	<0.5	<0.5	--	<0.5	<0.5	<0.5	<0.5	<0.5	<0.5
06/15/92	38	11	<0.5	<0.5	--	<0.5	<0.5	<0.5	<0.5	<0.5	<0.5
MW-5											
04/24/89	4.0	5.0	4.0	<1.0	2.0	--	--	<1.0	<1.0	--	--
07/28/89	5.6	4.0	5.3	0.3	--	<0.2	2.3	0.5	<0.2	--	--
10/30/89	2.9	2.0	2.7	<0.5	0.86	--	--	<0.5	<0.5	--	--
01/09/90	8.2	4.6	7.8	0.6	3.1	--	--	<0.5	<0.5	--	--
04/18/90	6.3	2.8	2.6	<0.5	1.7	--	--	<0.5	<0.5	<0.5	<0.5
08/09/90	11	4.8	6.0	<0.5	2.3	--	--	<0.5	<0.5	<0.5	<0.5
11/13/90	7.0	3.0	5.0	<0.5	--	<0.5	1	<0.5	<0.5	<0.5	<0.5
05/15/91	4.0	2.0	3.0	<0.5	--	<0.5	0.8	<0.5	<0.5	<0.5	<0.5
08/27/91	3.3	1.1	2.3	<0.5	--	--	<0.5	<0.5	<0.5	<0.5	<0.5
11/15/91	5.7	2.8	5.5	<0.5	--	<0.5	1.7	<0.5	<0.5	<0.5	<0.5
02/20/92	4.0	2.0	3.9	<0.5	--	<0.5	0.7	<0.5	<0.5	<0.5	<0.5
06/15/92	4.0	2.0	5.0	<0.5	--	<0.5	1.4	<0.5	<0.5	<0.5	<0.5

Cumulative Table of Well Data and Analytical Results

ADDITIONAL ANALYSES

Vertical Measurements are in feet.

Analytical values are in parts per billion (ppb).

DATE	Carbon Tet	Chloro-form	PCE	TCE	1, 2,-DCE	t-1, 2-DCE	c-1, 2-DCE	1, 1, 1-TCA	1,2-DCA	1, 2-DCP	1, 2-DCP
MW-6											
04/24/89	13	7.0	<1.0	<1.0	<1.0	--	--	<1.0	<1.0	--	--
07/28/89	9.6	4.0	<0.2	<0.2	--	<0.2	<0.2	0.5	0.6	--	--
10/30/89	8.2	3.6	<0.5	<0.5	<0.5	--	--	<0.5	<0.5	--	--
01/09/90	10	4.2	<0.5	<0.5	<0.5	--	--	<0.5	1.8	--	--
04/18/90	11	3.8	<0.5	<0.5	<0.5	--	--	<0.5	<0.5	<0.5	<0.5
08/09/90	20	6.6	<0.5	<0.5	<0.5	--	--	<0.5	<0.5	<0.5	<0.5
11/13/90	15	5.0	<0.5	<0.5	--	<0.5	<0.5	<0.5	<0.5	<0.5	<0.5
05/15/91	11	4.0	<0.5	<0.5	--	<0.5	<0.5	<0.5	<0.5	<0.5	<0.5
08/27/91	8.0	2.2	2.4	<0.5	--	--	<0.5	<0.5	<0.5	<0.5	<0.5
11/15/91	13	5.4	<0.5	<0.5	--	<0.5	<0.5	<0.5	0.8	<0.5	<0.5
02/20/92	11	4.0	<0.5	<0.5	--	<0.5	<0.5	<0.5	<0.5	<0.5	<0.5
06/15/92	9.6	4.2	<0.5	<0.5	--	<0.5	<0.5	<0.5	<0.5	<0.5	<0.5

Cumulative Table of Well Data and Analytical Results

ADDITIONAL ANALYSES

Vertical Measurements are in feet.

Analytical values are in parts per billion (ppb)

DATE	Carbon Tet	Chloro-form	PCE	TCE	1, 2,-DCE	t-1, 2-DCE	c-1, 2-DCE	1, 1, 1-TCA	1,2-DCA	1, 2-DCP	1, 2-DCP
MW-7											
04/24/89	3.0	9.0	<1.0	<1.0	<1.0	--	--	<1.0	<1.0	--	--
07/28/89	<2.0	<10	<2.0	<2.0	--	<2.0	<2.0	<10	6.0	--	--
07/28/89	<5.0	<20	<5.0	<5.0	--	<5.0	<0.5	<5.0	<5.0	--	--
10/30/89	<1.0	3.9	<1.0	<1.0	<1.0	--	--	<1.0	6.4	--	--
10/30/89	<1.0	3.1	<1.0	<1.0	<1.0	--	--	<1.0	6.2	--	--
01/09/90	<0.5	3.0	<0.5	<0.5	<0.5	--	--	<0.5	8.4	--	--
04/18/90	<0.5	3.2	<0.5	<0.5	<0.5	--	--	<0.5	7.7	0.6	0.6
08/09/90	3.3	7.7	<0.5	<0.5	<0.5	--	--	<0.5	8.4	<0.5	<0.5
11/13/90	0.6	3.0	<0.5	<0.5	--	<0.5	<0.5	<0.5	4.0	<0.5	<0.5
05/15/91	2.0	2.0	<0.5	<0.5	--	<0.5	<0.5	<0.5	3.0	<0.5	<0.5
08/27/91	0.7	2.8	<0.5	<0.5	--	--	<0.5	<0.5	2.7	<0.5	<0.5
11/15/91	0.8	2.7	<0.5	<0.5	--	<0.5	<0.5	<0.5	3.1	<0.5	<0.5
02/20/92	2.2	1.9	<0.5	<0.5	--	<0.5	<0.5	<0.5	3.3	<0.5	<0.5
06/15/92	1.1	1.8	<0.5	<0.5	--	<0.5	<0.5	<0.5	4.5	<0.5	<0.5
MW-8											
04/24/89	2.0	3.0	6.0	<1.0	4.0	--	--	<1.0	<1.0	--	--
04/24/89	2.0	2.0	6.0	<1.0	3.0	--	--	<1.0	<1.0	--	--
07/28/89	2.3	2.0	5.6	<0.2	--	<0.2	3.8	<0.2	<0.2	--	--
10/30/89	2.5	2.6	8.0	<0.5	5.5	--	--	<0.5	<0.5	--	--
01/09/90	4.9	3.9	19	0.9	6.6	--	--	<0.5	<0.5	--	--
04/18/90	3.8	2.8	17	0.6	5.7	--	--	<0.5	<0.5	<0.5	<0.5
08/09/90	5.3	4.4	27	1.2	9.2	--	--	<0.5	<0.5	<0.5	<0.5
11/13/90	3.0	2.0	21	0.7	--	<0.5	6.0	<0.5	<0.5	<0.5	<0.5
05/15/91	2.0	2.0	30	0.9	--	<0.5	6.0	<0.5	<0.5	<0.5	<0.5
08/27/91	1.4	1.1	32	1.0	--	--	4.7	<0.5	<0.5	<0.5	<0.5
11/15/91	1.5	1.9	50	<0.5	--	<0.5	5.8	<0.5	<0.5	2.0	2.0
02/20/92	1.3	2.3	68	2.4	--	<0.5	7.6	<0.5	<0.5	<0.5	<0.5
06/15/92	0.7	1.9	46	1.6	--	<0.5	5.6	<0.5	--	<0.5	<0.5

Cumulative Table of Well Data and Analytical Results

ADDITIONAL ANALYSES

Vertical Measurements are in feet.

Analytical values are in parts per billion (ppb)

DATE	Carbon Tet	Chloro-form	PCE	TCE	1, 2,-DCE	t-1, 2-DCE	c-1, 2-DCE	1, 1, 1-TCA	1,2-DCA	1, 2-DCP	1, 2-DCP
MW-9											
06/22/90	<0.5	<0.5	<0.5	<0.5	--	<0.5	--	<0.5	<0.5	<0.5	<0.5
08/09/90	<0.5	<0.5	<0.5	<0.5	<0.5	--	--	<0.5	0.71	<0.5	<0.5
11/13/90	<0.5	<0.5	<0.5	<0.5	--	<0.5	<0.5	<0.5	1.0	<0.5	<0.5
05/15/91	<0.5	<0.5	<0.5	<0.5	--	<0.5	<0.5	<0.5	0.5	<0.5	<0.5
08/27/91	<0.5	<0.5	<0.5	<0.5	--	--	<0.5	<0.5	<0.5	<0.5	<0.5
11/15/91	<0.5	<0.5	<0.5	<0.5	--	<0.5	<0.5	<0.5	0.6	<0.5	<0.5
02/20/92	<0.5	<0.5	<0.5	<0.5	--	<0.5	<0.5	<0.5	<0.5	<0.5	<0.5
06/15/92	<0.5	<0.5	<0.5	<0.5	--	<0.5	<0.5	<0.5	<0.5	<0.5	<0.5
MW-10											
06/22/90	9.6	8.9	<0.5	<0.5	--	<0.5	--	<0.5	<0.5	<0.5	<0.5
08/09/90	11	7.8	<0.5	<0.5	<0.5	--	--	<0.5	<0.5	<0.5	<0.5
11/13/90	5.0	4.0	<0.5	<0.5	--	<0.5	<0.5	<0.5	<0.5	<0.5	<0.5
05/15/91	5.0	4.0	<0.5	<0.5	--	<0.5	<0.5	<0.5	<0.5	<0.5	<0.5
08/27/91	6.9	3.4	<0.5	<0.5	--	--	<0.5	<0.5	<0.5	<0.5	<0.5
11/15/91	2.7	3.3	<0.5	<0.5	--	<0.5	<0.5	<0.5	<0.5	<0.5	<0.5
02/20/92	3.3	3.4	3.0	<0.5	--	<0.5	<0.5	<0.5	<0.5	<0.5	<0.5
06/15/92	4.5	2.9	<0.5	<0.5	--	<0.5	<0.5	<0.5	<0.5	<0.5	<0.5
MW-11											
06/22/90	4.6	6.5	73	1.3	--	<0.5	8.9	<0.5	<0.5	<0.5	<0.5
08/09/90	8.1	6.8	84	2.0	4.6	--	--	<0.5	<0.5	<0.5	<0.5
11/13/90	<0.5	<0.5	39	<0.5	--	<0.5	2.0	5	<0.5	<0.5	<0.5
05/15/91	1.0	3.0	7	0.5	--	<0.5	2.0	<0.5	<0.5	<0.5	<0.5
08/27/91	4.1	3.3	73	1.0	--	--	2.4	<0.5	<0.5	<0.5	<0.5
11/15/91	3.3	3.6	64	0.9	--	<0.5	2.3	<0.5	<0.5	<0.5	<0.5
02/20/92	<2.5	<2.5	62	<2.5	--	<2.5	<2.5	<2.5	<2.5	<2.5	<2.5
06/15/92	--	--	--	--	--	--	--	--	--	--	--

Cumulative Table of Well Data and Analytical Results

ADDITIONAL ANALYSES

Vertical Measurements are in feet.

Analytical values are in parts per billion (ppb)

DATE	Carbon Tet	Chloro-form	PCE	TCE	1, 2,-DCE	t-1, 2-DCE	c-1, 2-DCE	1, 1, 1-TCA	1,2-DCA	1, 2-DCP	1, 2-DCP
MW-12											
06/22/90	6.0	7.3	7.4	<0.5	--	<0.5	13	<0.5	<0.5	<0.5	<0.5
08/09/90	8.0	7.0	6.7	<0.5	5.8	--	--	<0.5	<0.5	<0.5	<0.5
11/13/90	<0.5	<0.5	9.0	<0.5	--	<0.5	3.0	3.0	<0.5	<0.5	<0.5
05/15/91	4.0	4.0	10	<0.5	--	<0.5	3.0	<0.5	<0.5	<0.5	<0.5
08/27/91	3.1	2.6	10	<0.5	--	--	2.3	<0.5	<0.5	<0.5	<0.5
11/15/91	1.9	3.5	8.9	<0.5	--	<0.5	5.9	<0.5	<0.5	<0.5	<0.5
02/20/92	3.3	3.4	3.7	<0.5	--	<0.5	<0.5	<0.5	<0.5	<0.5	<0.5
06/15/92	2.2	3.7	13	<0.5	--	<0.5	4.5	<0.5	<0.5	<0.5	<0.5
MW-13											
11/15/91	<0.5	<0.5	<0.5	--	<0.5	<0.5	<0.5	<0.5	<0.5	<0.5	<0.5
02/20/92	<0.5	<0.5	<0.5	--	<0.5	<0.5	<0.5	<0.5	<0.5	<0.5	<0.5
06/15/92	<0.5	<0.5	<0.5	--	--	<0.5	<0.5	<0.5	<0.5	<0.5	<0.5
MW-14											
11/15/91	<0.5	5.5	33	<0.5	--	<0.5	<0.5	<0.5	<0.5	<0.5	<0.5
02/20/92	<0.5	4.3	38	<0.5	--	<0.5	<0.5	<0.5	<0.5	<0.5	<0.5
06/15/92	--	--	--	--	--	--	--	--	--	--	--

Cumulative Table of Well Data and Analytical Results

ADDITIONAL ANALYSES

Vertical Measurements are in feet.

Analytical values are in parts per billion (ppb)

DATE	Carbon Tet	Chloro- form	PCE	TCE	1, 2,-DCE	1-1, 2-DCE	c-1, 2-DCE	1, 1, 1-TCA	1,2-DCA	1, 2-DCP	1, 2-DCP
TRIP BLANK											
11/03/88	<1.0	<1.0	<1.0	<1.0	--	<1.0	--	<1.0	<1.0	--	--
02/10/89	<0.1	<0.5	<0.1	<0.1	--	<0.1	<0.1	<0.1	<0.1	--	--
04/24/89	<1.0	<1.0	<1.0	<1.0	<1.0	--	--	<1.0	<1.0	--	--
07/28/89	<0.1	<0.5	<0.1	<0.5	<0.1	--	<0.1	<0.1	<0.1	--	--
10/30/89	<0.5	<0.5	<0.5	<0.5	<0.5	--	--	<0.5	<0.5	--	--
01/09/90	<0.5	<0.5	<0.5	<0.5	<0.5	--	--	<0.5	<0.5	--	--
04/18/90	<0.5	<0.5	<0.5	<0.5	<0.5	--	--	<0.5	<0.5	<0.5	<0.5
06/22/90	<0.5	<0.5	<0.5	<0.5	--	<0.5	--	<0.5	<0.5	<0.5	<0.5
08/09/90	<0.5	<0.5	<0.5	<0.5	<0.5	--	--	<0.5	<0.5	<0.5	<0.5
11/13/90	<0.5	0.5	<0.5	<0.5	--	<0.5	<0.5	<0.5	<0.5	<0.5	<0.5
05/15/91	--	--	--	--	--	--	--	--	--	--	--
08/27/91	--	--	--	--	--	--	--	--	--	--	--
11/15/91	<0.5	<0.5	<0.5	<0.5	--	<0.5	<0.5	<0.5	<0.5	<0.5	<0.5
02/20/92	<0.5	<0.5	<0.5	<0.5	--	<0.5	<0.5	<0.5	<0.5	<0.5	<0.5
06/15/92	<0.5	<0.5	<0.5	<0.5	--	<0.5	<0.5	<0.5	<0.5	<0.5	<0.5

Cumulative Table of Well Data and Analytical Results

TABLE 2 OF ADDITIONAL ANALYSES

Vertical Measurements are in feet.

Analytical values are in parts per billion (ppb)

DATE	2-butanone	Acetone	1, 1- DCE	1, 1- DCA	Chloro- benzene	Chloro- benzene
MW-3 08/27/91	--	--	1.3	0.5	0.7	0.7
MW-7 04/24/89	160	5.0	--	--	--	--
MW-13 11/15/91	--	--	--	0.6	--	--

Note: Blaine Tech Services, Inc. began routine monitoring of the groundwater wells at this site on November 1, 1994.

Earlier field data and analytical results are drawn from the September 27, 1994 Groundwater Technology, Inc. report.

ABBREVIATIONS:

TPH = Total Petroleum Hydrocarbons

TOG = Total Oil and Grease

Carbon Tet = Carbon Tetrachloride

PCE = Tetrachloroethene

TCE = Trichloroethene

1,2-DCE = 1,2-Dichloroethene

t-1,2-DCE = trans-1,2-Dichloroethene

c-1,2-DCE = cis-1,2-Dichloroethene

1,1,1-TCA = 1,1,1-Trichloroethane

1,2-DCA = 1,2-Dichloroethane

1,2-DCP = 1,2-Dichloropropane

1,1-DCE = 1,1-Dichloroethene

MC = Methylene chloride

Analytical Appendix



April 13, 2000

Scott Boor
Blaine Tech Services (Chev)
1680 Rogers Avenue
San Jose, CA 95112

RE: Chevron

Dear Scott Boor

Enclosed are the results of analyses for sample(s) received by the laboratory on March 28, 2000. If you have any questions concerning this report, please feel free to contact me.

Sincerely,

Jeff Smyly
Project Manager

CA ELAP Certificate Number 1210





Blaine Tech Services (Chev) 1680 Rogers Avenue San Jose, CA 95112	Project: Chevron 9-0020 Project Number: 000327-F1(1633 HARRISON ST) Project Manager: Scott Boor	Sampled: 3/27/00 Received: 3/28/00 Reported: 4/13/00 16:23
---	---	--

ANALYTICAL REPORT FOR SAMPLES:

Sample Description	Laboratory Sample Number	Sample Matrix	Date Sampled
MW-7	MJC0951-01	Water	3/27/00
MW-13	MJC0951-02	Water	3/27/00
MW-15	MJC0951-03	Water	3/27/00
TB	MJC0951-04	Water	3/27/00

Sequoia Analytical - Morgan Hill

*The results in this report apply to the samples analyzed in accordance with the chain of custody document.
This analytical report must be reproduced in its entirety.*

Wendy Bonnes, Department Manager





Blaine Tech Services (Chev) 1680 Rogers Avenue San Jose, CA 95112	Project: Chevron 9-0020 Project Number: 000327-F1(1633 HARRISON ST) Project Manager: Scott Boor	Sampled: 3/27/00 Received: 3/28/00 Reported: 4/13/00 16:23
---	---	--

**Total Purgeable Hydrocarbons (C6-C12), BTEX and MTBE by DHS LUFT
Sequoia Analytical - Morgan Hill**

Analyte	Batch Number	Date Prepared	Date Analyzed	Specific Method	Reporting Limit	Result	Units	Notes*
MW-7				MJC0951-01			Water	H-06
Purgeable Hydrocarbons	0D11004	4/11/00	4/11/00	DHS LUFT	50.0	721	ug/l	P-01
Benzene	"	"	"	DHS LUFT	0.500	38.5	"	
Toluene	"	"	"	DHS LUFT	0.500	1.06	"	
Ethylbenzene	"	"	"	DHS LUFT	0.500	6.31	"	
Xylenes (total)	"	"	"	DHS LUFT	0.500	9.38	"	
Methyl tert-butyl ether	"	"	"	DHS LUFT	2.50	7.75	"	
Surrogate: a,a,a-Trifluorotoluene	"	"	"	70-130		97.0	%	
MW-13				MJC0951-02			Water	
Purgeable Hydrocarbons	0D10004	4/10/00	4/10/00	DHS LUFT	50.0	89.5	ug/l	P-01
Benzene	"	"	"	DHS LUFT	0.500	0.765	"	
Toluene	"	"	"	DHS LUFT	0.500	0.682	"	
Ethylbenzene	"	"	"	DHS LUFT	0.500	ND	"	
Xylenes (total)	"	"	"	DHS LUFT	0.500	0.688	"	
Methyl tert-butyl ether	"	"	"	DHS LUFT	2.50	4.04	"	
Surrogate: a,a,a-Trifluorotoluene	"	"	"	70-130		91.9	%	
MW-15				MJC0951-03			Water	
Purgeable Hydrocarbons	0D10004	4/10/00	4/10/00	DHS LUFT	50.0	ND	ug/l	
Benzene	"	"	"	DHS LUFT	0.500	ND	"	
Toluene	"	"	"	DHS LUFT	0.500	ND	"	
Ethylbenzene	"	"	"	DHS LUFT	0.500	ND	"	
Xylenes (total)	"	"	"	DHS LUFT	0.500	ND	"	
Methyl tert-butyl ether	"	"	"	DHS LUFT	2.50	ND	"	
Surrogate: a,a,a-Trifluorotoluene	"	"	"	70-130		100	%	
TB				MJC0951-04			Water	
Purgeable Hydrocarbons	0D10004	4/10/00	4/10/00	DHS LUFT	50.0	ND	ug/l	
Benzene	"	"	"	DHS LUFT	0.500	ND	"	
Toluene	"	"	"	DHS LUFT	0.500	ND	"	
Ethylbenzene	"	"	"	DHS LUFT	0.500	ND	"	
Xylenes (total)	"	"	"	DHS LUFT	0.500	ND	"	
Methyl tert-butyl ether	"	"	"	DHS LUFT	2.50	ND	"	
Surrogate: a,a,a-Trifluorotoluene	"	"	"	70-130		104	%	





Blaine Tech Services (Chev) 1680 Rogers Avenue San Jose, CA 95112	Project: Chevron 9-0020 Project Number: 000327-F1(1633 HARRISON ST) Project Manager: Scott Boor	Sampled: 3/27/00 Received: 3/28/00 Reported: 4/13/00 16:23
---	---	--

**Total Purgeable Hydrocarbons (C6-C12), BTEX and MTBE by DHS LUFT/Quality Control
Sequoia Analytical - Morgan Hill**

Analyte	Date Analyzed	Spike Level	Sample Result	QC Result	Units	Reporting Limit Recov. Limits	Recov. %	RPD Limit	RPD %	Notes*
Batch: 0D10004		Date Prepared: 4/10/00			Extraction Method: EPA 5030B (P/T)					
Blank		0D10004-BLK1								
Purgeable Hydrocarbons	4/10/00			ND	ug/l	50.0				
Benzene	"			ND	"	0.500				
Toluene	"			ND	"	0.500				
Ethylbenzene	"			ND	"	0.500				
Xylenes (total)	"			ND	"	0.500				
Methyl tert-butyl ether	"			ND	"	2.50				
Surrogate: a,a,a-Trifluorotoluene	"	10.0		9.65	"	70-130	96.5			
LCS		0D10004-BS1								
Purgeable Hydrocarbons	4/10/00	250		215	ug/l	70-130	86.0			
Surrogate: a,a,a-Trifluorotoluene	"	10.0		8.93	"	70-130	89.3			
Matrix Spike		0D10004-MS1 MJC0951-03								
Purgeable Hydrocarbons	4/10/00	250	ND	217	ug/l	60-140	86.8			
Surrogate: a,a,a-Trifluorotoluene	"	10.0		8.31	"	70-130	83.1			
Matrix Spike Dup		0D10004-MSD1 MJC0951-03								
Purgeable Hydrocarbons	4/10/00	250	ND	213	ug/l	60-140	85.2	25	1.86	
Surrogate: a,a,a-Trifluorotoluene	"	10.0		8.74	"	70-130	87.4			
Batch: 0D11004		Date Prepared: 4/11/00			Extraction Method: EPA 5030B (P/T)					
Blank		0D11004-BLK1								
Purgeable Hydrocarbons	4/11/00			ND	ug/l	50.0				
Benzene	"			ND	"	0.500				
Toluene	"			ND	"	0.500				
Ethylbenzene	"			ND	"	0.500				
Xylenes (total)	"			ND	"	0.500				
Methyl tert-butyl ether	"			ND	"	2.50				
Surrogate: a,a,a-Trifluorotoluene	"	10.0		10.0	"	70-130	100			
LCS		0D11004-BS1								
Benzene	4/11/00	10.0		11.0	ug/l	70-130	110			
Toluene	"	10.0		9.77	"	70-130	97.7			
Ethylbenzene	"	10.0		9.26	"	70-130	92.6			
Xylenes (total)	"	30.0		27.8	"	70-130	92.7			
Surrogate: a,a,a-Trifluorotoluene	"	10.0		10.3	"	70-130	103			





Blaine Tech Services (Chev) 1680 Rogers Avenue San Jose, CA 95112	Project: Chevron 9-0020 Project Number: 000327-F1(1633 HARRISON ST) Project Manager: Scott Boor	Sampled: 3/27/00 Received: 3/28/00 Reported: 4/13/00 16:23
---	---	--

Notes and Definitions

#	Note
---	------

- H-06 The result reported was generated out of hold time. The sample was originally run within hold time, but needed to be re-analyzed.
- P-01 Chromatogram Pattern: Gasoline C6-C12
- DET Analyte DETECTED
- ND Analyte NOT DETECTED at or above the reporting limit
- NR Not Reported
- dry Sample results reported on a dry weight basis
- Recov. Recovery
- RPD Relative Percent Difference



Fax copy of Lab Report and COC to Chevron Contact: Yes No

Chain-of-Custody-Record

Chevron Products Co. P.O. BOX 6004 San Ramon, CA 94583 FAX (925)842-8370	Chevron Facility Number <u>9-0020</u>	Chevron Contact Name) <u>Brett Hunter</u>
	Facility Address <u>1633 Harrison St., Oakland</u>	(Phone) <u>(925) 842-8695</u>
	Consultant Project Number <u>000327 F1</u>	Laboratory Name <u>Sequoia</u>
	Consultant Name <u>Blaine Tech Services, Inc.</u>	Laboratory Service Order <u>9144488</u>
	Address <u>1680 Rogers Ave., San Jose</u>	Laboratory Service Code <u>ZZ02790</u>
	Project Contact (Name) <u>Scott Boor</u>	Samples collected by (Name) <u>Mick Stewart</u>
	(Phone) <u>408-573-0555</u> (Fax) <u>408-573-7771</u>	Signature <u>[Signature]</u>

State Method: CA OR WA NW Series CO UT

Sample Number	Number of Containers	Matrix S = Soil W = Water A = Air C = Charcoal	Sample Preservation	Date/Time	State Method: <input type="checkbox"/> CA <input type="checkbox"/> OR <input type="checkbox"/> WA <input type="checkbox"/> NW Series <input type="checkbox"/> CO <input type="checkbox"/> UT														Remarks		
					BTEX/MTBE + TPH GAS (8020 + 8015)	BTEX + TPH GAS (8020 + 8015)	TPH Diesel (8015)	Oxygenates (8260)	Purgeable Halocarbons (8010)	Purgeable Organics (8270)	Extractable Organics (8270)	Oil and Grease (5520)	Metals (ICAP or AA) Cd, Cr, Pb, Zn, Ni	BTEX (8020)	BTEX/MTBE/Naph. (8020)	TPH - HCID	TPH - D Extended	Lab Sample No.			
MW-7	3	W	HCL	3-27/004	X																
MW-13				810	X																
MW-15				840	X																
TB	2	W	HCL	3-27/	X																

MJC 0951

CE 28 10 18

Relinquished By (Signature) <u>[Signature]</u>	Organization <u>BTS</u>	Date/Time <u>3/28/00 8:09</u>	Received By (Signature) <u>[Signature]</u>	Organization <u>SEQUIA</u>	Date/Time <u>3/28/00</u>	Iced Y/N	Turn Around Time (Circle One) 24 Hrs. 48 Hrs. 5 Days 10 Days As Contracted
Relinquished By (Signature)	Organization	Date/Time	Received By (Signature)	Organization	Date/Time	Iced Y/N	
Relinquished By (Signature)	Organization	Date/Time	Received For Laboratory By (Signature)	Organization	Date/Time	Iced Y/N	

COC-3.DWG/07-98/HCH

Field Data Sheets

WELL GAUGING DATA

Project # 000327F1 Date 3-27-00 Client Chevron

Site 1633 Harrison st. Oakland Ca.

Well ID	Well Size (in.)	Sheen / Odor	Depth to Immiscible Liquid (ft.)	Thickness of Immiscible Liquid (ft.)	Volume of Immiscibles Removed (ml)	Depth to water (ft.)	Depth to well bottom (ft.)	Survey Point: TOB or TOB
MW-7	4					19.59	26.50	}
MW-9	2	Filled in w/ Asphalt				-	-	
MW-13	2					20.04	27.10	
MW-15	2					19.67	26.76	
MW-16	2	(Inaccessible due to car parked over well all morning:)						

CHEVRON WELL MONITORING DATA SHEET

Project #: <u>000327 F1</u>	Station #: <u>9-0020</u>
Sampler: <u>MIKE S.</u>	Date: <u>3-27-00</u>
Well I.D.: <u>MW-7</u>	Well Diameter: 2 3 <u>4</u> 6 8 _____
Total Well Depth: <u>26.50</u>	Depth to Water: <u>19.59</u>
Depth to Free Product:	Thickness of Free Product (feet):
Referenced to: <u>PVC</u> Grade	D.O. Meter (if req'd): YSI HACH

Well Diameter	Multiplier	Well Diameter	Multiplier
2"	0.16	5"	1.02
3"	0.37	6"	1.47
4"	0.65	Other	radius ² * 0.163

Purge Method: Bailer Sampling Method: Bailer
 Disposable Bailer Disposable Bailer
 Middleburg Extraction Port
 Electric Submersible Other: _____
 Extraction Pump

<u>4.4</u>	X	<u>3</u>	=	<u>13.4</u>	Gals.
1 Case Volume (Gals.)		Specified Volumes		Calculated Volume	

Time	Temp (°F)	pH	Cond.	Gals. Removed	Observations
857	62.8	6.7	530	5	0002 / cloudy
858	62.7	6.5	533	10	↓ / ↓
859	62.9	6.5	539	14	↓ / ↓
*(REMOVE ORG'S TO SAMPLE) 000					

Did well dewater? Yes No Gallons actually evacuated: 14

Sampling Time: 904 Sampling Date: 3-27-00

Sample I.D.: MW-7 Laboratory: Sequoia CORE N. Creek Assoc. Labs

Analyzed for: TPH-G BTEX MTBE TPH-D Other:

Duplicate I.D.: Analyzed for: TPH-G BTEX MTBE TPH-D Other:

D.O. (if req'd):	Pre-purge:	mg/L	Post-purge:	mg/L
O.R.P. (if req'd):	Pre-purge:	mV	Post-purge:	mV

CHEVRON WELL MONITORING DATA SHEET

Project #: <u>000327 F1</u>	Station #: <u>9-0020</u>
Sampler: <u>MIKE S.</u>	Date: <u>3-27-00</u>
Well I.D.: <u>MW-9</u>	Well Diameter: 2 3 4 6 8 <u> </u>
Total Well Depth: <u> </u>	Depth to Water: <u> </u>
Depth to Free Product: <u> </u>	Thickness of Free Product (feet): <u> </u>
Referenced to: <u>(PVC)</u> Grade	D.O. Meter (if req'd): YSI HACH

Well Diameter	Multiplier	Well Diameter	Multiplier
2"	0.16	5"	1.02
3"	0.37	6"	1.47
4"	0.65	Other	radius ² * 0.163

Purge Method:	Sampling Method:
Bailer Disposable Bailer Middleburg Electric Submersible Extraction Pump Other: <u> </u>	Bailer Disposable Bailer Extraction Port Other: <u> </u>

_____	X	_____	=	_____	Gals.
1 Case Volume (Gals.)		Specified Volumes		Calculated Volume	

Time	Temp (°F)	pH	Cond.	Gals. Removed	Observations
					<u>filled in w/ Asphalt, well box is still there.</u>

Did well dewater?	Yes	<input checked="" type="checkbox"/>	No	<input type="checkbox"/>	Gallons actually evacuated: _____
Sampling Time:					Sampling Date:
Sample I.D.:					Laboratory: <u>Sequoia CORE N. Creek Assoc. Labs</u>
Analyzed for:	TPH-G	BTEX	MTBE	TPH-D	Other: _____
Duplicate I.D.:					Analyzed for: TPH-G BTEX MTBE TPH-D Other: _____
D.O. (if req'd):	Pre-purge:	_____ mg/L	Post-purge:	_____ mg/L	
O.R.P. (if req'd):	Pre-purge:	_____ mV	Post-purge:	_____ mV	

CHEVRON WELL MONITORING DATA SHEET

Project #: <u>000321 F1</u>	Station #: <u>9-0020</u>
Sampler: <u>MIKE S.</u>	Date: <u>3-27-00</u>
Well I.D.: <u>MW-13</u>	Well Diameter: <u>(2)</u> 3 4 6 8
Total Well Depth: <u>27.10</u>	Depth to Water: <u>20.04</u>
Depth to Free Product:	Thickness of Free Product (feet):
Referenced to: <u>(PVC)</u> Grade	D.O. Meter (if req'd): YSI HACH

Well Diameter	Multiplier	Well Diameter	Multiplier
2"	0.16	5"	1.02
3"	0.37	6"	1.47
4"	0.65	Other	radius ² * 0.163

Purge Method: <input type="checkbox"/> Bailer <input checked="" type="checkbox"/> Disposable Bailer <input type="checkbox"/> Middleburg <input type="checkbox"/> Electric Submersible <input type="checkbox"/> Extraction Pump Other: _____	Sampling Method: <input type="checkbox"/> Bailer <input checked="" type="checkbox"/> Disposable Bailer <input type="checkbox"/> Extraction Port Other: _____
--	---

<u>1.1</u>	X	<u>3</u>	=	<u>3.3</u>	Gals.
1 Case Volume (Gals.)		Specified Volumes		Calculated Volume	

Time	Temp (°F)	pH	Cond.	Gals. Removed	Observations
<u>801</u>	<u>63.9</u>	<u>6.4</u>	<u>805</u>	<u>2</u>	<u>cloudy</u>
<u>804</u>	<u>63.4</u>	<u>6.4</u>	<u>815</u>	<u>3</u>	<u>↓</u>
<u>806</u>	<u>63.2</u>	<u>6.5</u>	<u>813</u>	<u>4</u>	<u>✓</u>

Did well dewater? Yes <input type="checkbox"/> <u>(No)</u>	Gallons actually evacuated: <u>4</u>
Sampling Time: <u>810</u>	Sampling Date: <u>3-27-00</u>
Sample I.D.: <u>MW-13</u>	Laboratory: <u>(Sequoia)</u> CORE N. Creek Assoc. Labs
Analyzed for: <u>(TPH-G)</u> <u>(BTEX)</u> <u>(MTBE)</u> TPH-D Other:	
Duplicate I.D.:	Analyzed for: TPH-G BTEX MTBE TPH-D Other:
D.O. (if req'd):	Pre-purge: <u>mg/L</u> Post-purge: <u>mg/L</u>
O.R.P. (if req'd):	Pre-purge: <u>mV</u> Post-purge: <u>mV</u>

CHEVRON WELL MONITORING DATA SHEET

Project #: 000327 F1	Station #: 9-0020
Sampler: MIKE S.	Date: 3-27-00
Well I.D.: MW-15	Well Diameter: (2) 3 4 6 8
Total Well Depth: 26.73	Depth to Water: 19.67
Depth to Free Product:	Thickness of Free Product (feet):
Referenced to: (PVC) Grade	D.O. Meter (if req'd): YSI HACH

Well Diameter	Multiplier	Well Diameter	Multiplier
2"	0.16	5"	1.02
3"	0.37	6"	1.47
4"	0.65	Other	radius ² * 0.163

Purge Method: <input type="checkbox"/> Bailer <input checked="" type="checkbox"/> Disposable Bailer <input type="checkbox"/> Middleburg <input type="checkbox"/> Electric Submersible <input type="checkbox"/> Extraction Pump Other: _____	Sampling Method: <input type="checkbox"/> Bailer <input checked="" type="checkbox"/> Disposable Bailer <input type="checkbox"/> Extraction Port Other: _____
--	---

<u>1.1</u>	x	<u>3</u>	=	<u>3.3</u>	Gals.
1 Case Volume (Gals.)		Specified Volumes		Calculated Volume	

Time	Temp (°F)	pH	Cond.	Gals. Removed	Observations
829	62.1	6.5	593	2	
834	61.9	6.4	590	3	
838	61.7	6.5	591	4	

Did well dewater? Yes <input type="checkbox"/> (No) <input checked="" type="checkbox"/>	Gallons actually evacuated: 4
Sampling Time: 840	Sampling Date: 3-27-00
Sample I.D.: MW-15	Laboratory: (Sequoia) CORE N. Creek Assoc. Labs
Analyzed for: (TPH-G) (BTEX) (MTBE) TPH-D Other:	
Duplicate I.D.:	Analyzed for: TPH-G BTEX MTBE TPH-D Other:
D.O. (if req'd):	Pre-purge: _____ mg/L Post-purge: _____ mg/L
O.R.P. (if req'd):	Pre-purge: _____ mV Post-purge: _____ mV

CHEVRON WELL MONITORING DATA SHEET

Project #: <u>000327 F1</u>	Station #: <u>9-0020</u>
Sampler: <u>MIKE S.</u>	Date: <u>3-27-00</u>
Well I.D.: <u>MW-16</u>	Well Diameter: 2 3 4 6 8 <u> </u>
Total Well Depth: <u> </u>	Depth to Water: <u> </u>
Depth to Free Product: <u> </u>	Thickness of Free Product (feet): <u> </u>
Referenced to: PVC Grade	D.O. Meter (if req'd): YSI HACH

Well Diameter	Multiplier	Well Diameter	Multiplier
2"	0.16	5"	1.02
3"	0.37	6"	1.47
4"	0.65	Other	radius ² * 0.163

Purge Method: <u>Bailer</u>	Sampling Method: <u>Bailer</u>
<u>Disposable Bailer</u>	<u>Disposable Bailer</u>
<u>Middleburg</u>	<u>Extraction Port</u>
<u>Electric Submersible</u>	Other: <u> </u>
<u>Extraction Pump</u>	
Other: <u> </u>	

	X		=		Gals.
1 Case Volume (Gals.)		Specified Volumes		Calculated Volume	

Time	Temp (°F)	pH	Cond.	Gals. Removed	Observations
					<u>Inaccessible, Car parked over well. Waited 35 min before leaving the site to see if it would become accessible.</u>
					<u>Also returned to site later and spent 30 min. waiting for car to be moved.</u>

Did well dewater?	Yes	<input checked="" type="checkbox"/> No	Gallons actually evacuated: <u> </u>
Sampling Time: <u> </u>	Sampling Date: <u> </u>		
Sample I.D.: <u> </u>	Laboratory: <u>Sequoia CORE N. Creek Assoc. Labs</u>		
Analyzed for: TPH-G BTEX MTBE TPH-D Other: <u> </u>			
Duplicate I.D.: <u> </u>	Analyzed for: TPH-G BTEX MTBE TPH-D Other: <u> </u>		
D.O. (if req'd):	Pre-purge: <u> </u> mg/L	Post-purge: <u> </u> mg/L	
O.R.P. (if req'd):	Pre-purge: <u> </u> mV	Post-purge: <u> </u> mV	