

Shields, Harper & Co.

INCORPORATED

PAGE 1 119-00

DATE 06-19-95

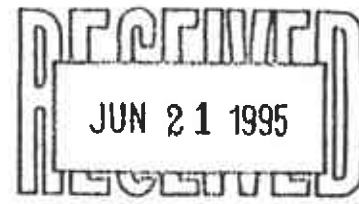

TO Tait & Associates

ATTN: Tom Schoenstien

ADDRESS Galaxy Way, Stu. 404, Concord, CA 94520

JOB Arco Blanket Contract Shields, Harper on hand trim items.

DUE DATE 6-19-95

ITEM	QUAN	WE ARE PLEASED TO QUOTE ON THE FOLLOWING SUBJECT TO CONDITIONS PRINTED BELOW.	UNIT PRICE	TOTAL
1		7044 CNI 36 in manhole w/screws/gasket		
2		V421-2020 Universal 2 x 2 vent less float		
3		37-201216 Universal 2 x 12 float vent valve		
4		110165-32-0240 Titiflex 2 in x 24 in M/SW flex connector		
5		1056-32 Fernco 3 in x 2 in reducer WO/test port		
6		1052-C CNI 36 in manhole w/2 5 gal sumps		
7		724-4040 4 x 4 brass adapter		
8		733-40 Universal 4 in fill cap		
9		0611V-3040 Universal 3 x 4 vapor check valve		
10		0614VC-30 Universal 3 in vapor valve cap		
11		A1100-001 Emco Wheaton Guardian overfill valve		
12		A20-004 Emco Wheaton 4 x 12 ft drop tube - alum		
13		TR5002 Total Containment Flexible entry boot		
14		AC-10 American Containment 3/4 in compression fitting		
15		521DP-RM-15 Male double poppet safety valve		
16		1321-D CNI Stabilizer box - dual		
17		1321-S CNI Stabilizer box - single		
18		110165-24-0240 Titiflex 1-1/2 in x 24 in M/SW flex connector		
19		350030 Containment Tech 30 in boot		
20		781-418-08 EBW 18 in round manhole		

QUOTATION

UTILITY BOXES AND MANHOLES

SPECIFICATIONS:

OUTER RING: Heavy cast iron or 12 gauge steel
COVER: 3/8" non-skid floor plate
SKIRT: 14 gauge sheet metal

FEATURES:

- * Reinforced cover complies with H20 rating, lift handle on all covers 24" and larger
- * All boxes requiring screw-down covers are equipped with 3/8"-16 Allen flat-head screws, zinc plated
- * Screws also available in stainless steel
- * Tamper proof Allen screws are available as an option
- * Brass tag available for outer ring
- * Outer ring has 4 tie-downs to insert a bent piece of #4 re-bar, to anchor box in concrete

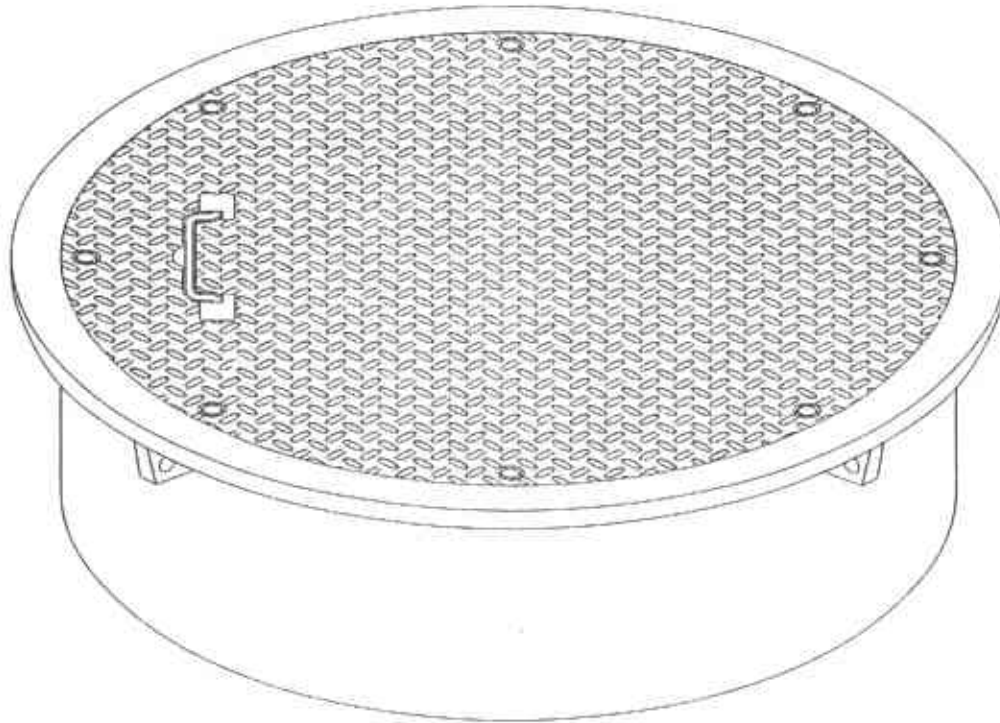

MANHOLE DIMENSIONS							
SIZE	CAST IRON RINGS			STEEL RINGS			REINFORCED
	DIM."A"	DIM. "B"	DIM "C"	DIM."A"	DIM. "B"	DIM "C"	
8"	9"	6"	8"	N/A	N/A	N/A	NO
12"	14-1/8"	9-5/16"	8" & 12"	N/A	N/A	N/A	NO
16"	17-13/16"	13"	8" & 12"	N/A	N/A	N/A	NO
18"	20-3/8"	15-1/16"	8" & 12"	N/A	N/A	N/A	NO
24"	27"	20-1/8"	12"	24-1/4"	21-1/8"	12"	YES
30"	33"	27-1/8"	12"	30-1/2"	27-3/8"	12"	YES
36"	40-3/16"	32-1/2"	12"	36-3/8"	33-3/16"	12"	YES
42"	46"	38-7/8"	12"	43"	39-3/4"	12"	YES
48"	52-1/8"	44-3/4"	12"	48-1/2"	45-3/16"	12"	YES

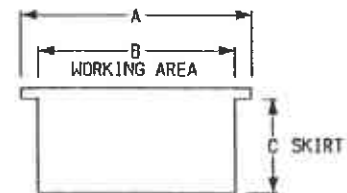
**NOTE: CAM-LOK
REQUIREMENTS:**

24" & 30"	4 CAM-LOKS
36"	5 CAM-LOKS
42"	6 CAM-LOKS
48"	7 CAM-LOKS

OPTIONS: H=HINGE COVER K=LOCKING HASP

15627 ARROW HIGHWAY • IRWINDALE, CA 91706

16 (818) 962 - 6646 • FAX: (818) 962 - 4854 • OUT OF STATE ONLY: 1-800-4CNI-MFG

UTILITY BOXES



CAST IRON (SCREWS AND GASKETS)

SIZE	WITH	WITHOUT
	PART #	PART #
8" DIA X 8" SKIRT	7002	7000
12" DIA X 8" SKIRT	7008	7006
12" DIA X 12" SKIRT	7011	7009
16" DIA X 8" SKIRT	7017	7015
16" DIA X 12" SKIRT	7020	7018
18" DIA X 8" SKIRT	7026	7024
18" DIA X 12" SKIRT	7029	7027

MANHOLES (REINFORCED)

CAST IRON (SCREWS AND GASKETS)

STEEL (SCREWS AND GASKETS)

	CAST IRON		STEEL	
	WITH	WITHOUT	WITH	WITHOUT
24" DIA X 12" SKIRT	7034	7033	8034	8033
30" DIA X 12" SKIRT (ONE HANDLE)	7039	7038	8039	8038
36" DIA X 12" SKIRT	7044 ←	7043	8044	8043
42" DIA X 12" SKIRT	7049	7048	8049	8048
48" DIA X 12" SKIRT (TWO HANDLES)	7054	7053	8054	8053

ITEMS WITH SCREWS AND GASKETS ARE WATERTIGHT



VAPOR RECOVERY & OVERFILL PROTECTION ACCESSORIES



V420 V421

VENT VALVE ASSEMBLY - Allows manifolding of tank lines. Can be used in conjunction with Universal Float Vent Valve 37 or 38, for overfill protection. Also reduces product crossover in manifolded vapor recovery systems. V421 includes V423 Cage Assembly (used with 37); V420 does not include V423 Cage Assembly (used with 38).

Model #	Port Size	Weight (lbs.)	Height	Width
V420-0000	0" x 0"	18.4	8"	6 ⁵ / ₈ "
V420-0020	0" x 2"	16.2	8"	6 ⁵ / ₈ "
V420-2020	2" x 2"	15.7	8"	6 ⁵ / ₈ "
V420-0030	0" x 3"	18.0	8"	6 ⁵ / ₈ "
V420-3020	3" x 2"	16.7	8"	6 ⁵ / ₈ "
V420-3030	3" x 3"	17.6	8"	6 ⁵ / ₈ "
V421-0000	0" x 0"	18.4	8"	6 ⁵ / ₈ "
V421-0020	0" x 2"	16.2	8"	6 ⁵ / ₈ "
V421-2020	2" x 2"	15.7	8"	6 ⁵ / ₈ "
V421-0030	0" x 3"	18.0	8"	6 ⁵ / ₈ "
V421-3020	3" x 2"	16.7	8"	6 ⁵ / ₈ "
V421-3030	3" x 3"	17.6	8"	6 ⁵ / ₈ "

- Allows manifolding of tank lines
- Easy mounting on UST flange
- Properly positions the Float Vent Valve
- Polymeric-coated cast iron body
- Standard 4" inlet and outlet

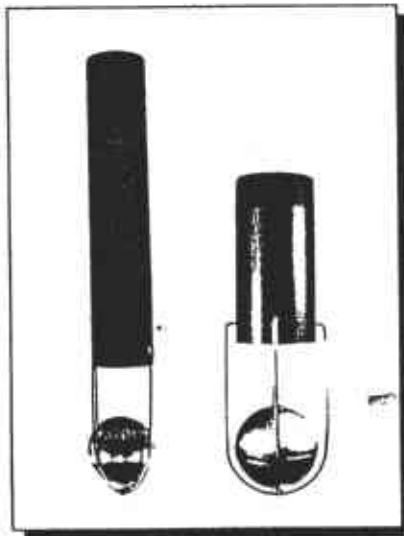

37

FLOAT VENT VALVE - Used in conjunction with the Model V421 Vent Valve Assembly to protect against overfill of USTs by signaling the transport driver when the tank is filled to 90% capacity, in accordance with EPA guidelines. Fuel levels force the stainless steel ball to seat tightly against a specially-designed valve seat, which restricts the venting system and slows delivery rate dramatically, alerting the transport driver to stop product drop.

Model #	Size	Bleed Hole Size	Weight (lbs.)	Height	Width
37-206000	2" x 6"	0"	1.5	9 ¹ / ₂ "	3 ¹ / ₈ "
37-206018	2" x 6"	1/8"	1.5	9 ¹ / ₂ "	3 ¹ / ₈ "
37-206016	2" x 6"	1/16"	1.5	9 ¹ / ₂ "	3 ¹ / ₈ "
37-201218	2" x 12"	1/8"	3.7	16 ¹ / ₂ "	3 ¹ / ₈ "
37-201216	2" x 12"	1/16"	3.7	16 ¹ / ₂ "	3 ¹ / ₈ "
37-201618	2" x 16"	1/8"	4.4	19 ¹ / ₂ "	3 ¹ / ₈ "
37-201616	2" x 16"	1/16"	4.4	19 ¹ / ₂ "	3 ¹ / ₈ "
37-202118	2" x 21"	1/8"	6.2	24 ¹ / ₂ "	3 ¹ / ₈ "
37-202116	2" x 21"	1/16"	6.2	24 ¹ / ₂ "	3 ¹ / ₈ "

- Prevents product mixing
- Easily extracted to allow tank testing
- Easy to install
- Polymeric-coated steel body
- Galvanized steel cage
- Stainless steel float ball

TIT E FLEX

GUIDE to UL and ULC LISTED FLEXIBLE CONNECTORS

SOIL SAFE 30
FIRE SAFE
SOIL SAFE 20
STAINLESS BRAIDED
SOIL SAFE APC

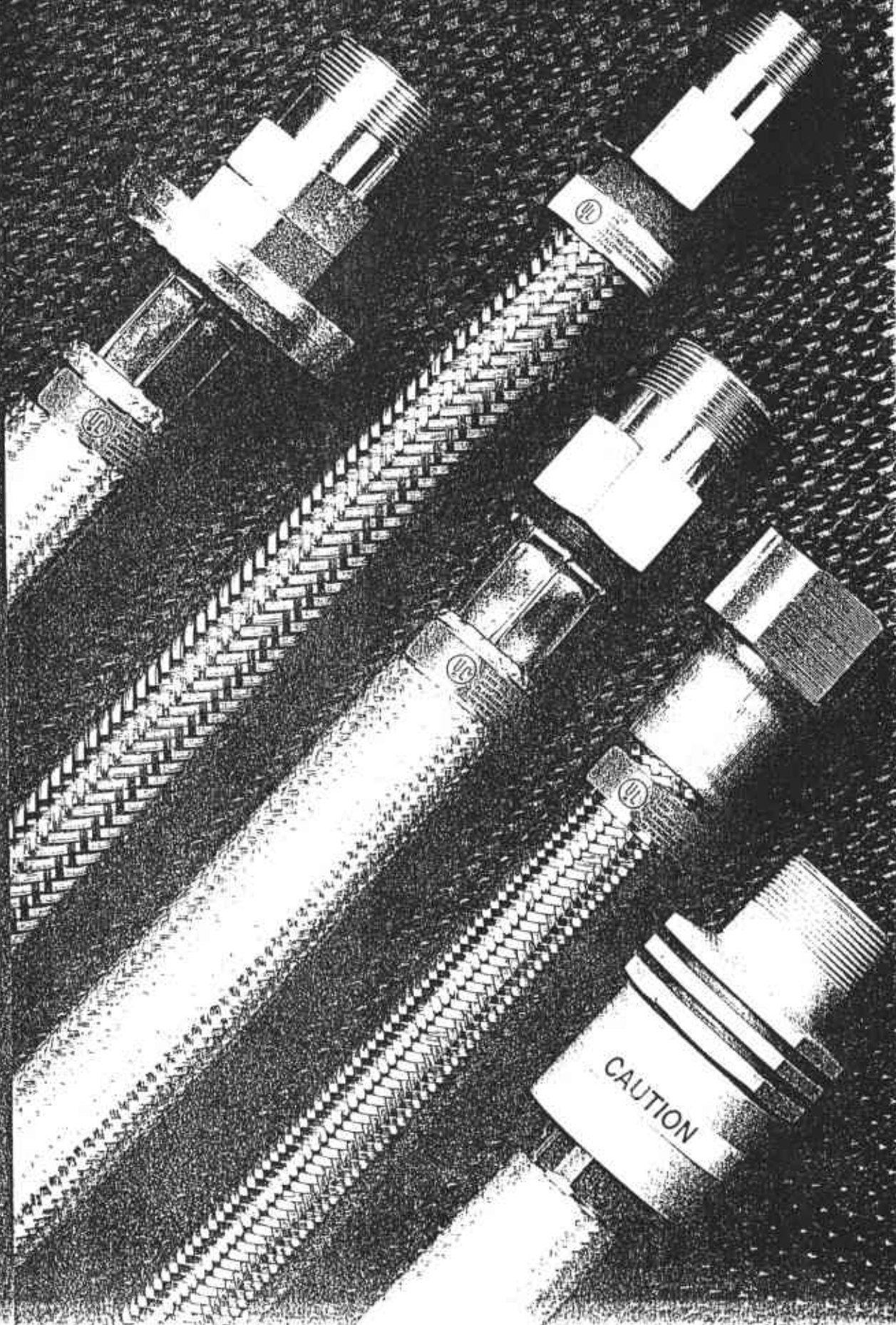

TITEFLEX UNDERGROUND FLEX CONNECTORS

Male Pipe	108992-24-L	(550)	4.5	111360-24-L	(150)	4.5	111398-24-L	(150)
x Male Pipe	-32-L	(400)	6.0	-32-L	(150)	6.0	-32-L	(150)
	-48-L	(50)	15.0	-48-L	(50)	15.0	-48-L	(50)
Male Pipe	110165-24-L	(150)		111394-24-L	(150)		111404-24-L	(150)
x Swivel Male	-32-L	(150)		-32-L	(150)		-32-L	(150)
Swivel Male	111430-24-L	(150)		111450-24-L	(150)		111431-24-L	(150)
x Female (2")	-32-L	(150)		-32-L	(150)		-32-L	(150)
Male Pipe	111351-24-L	(550)		111393-24-L	(150)		111415-24-L	(150)
x Female (2")	-32-L	(400)		-32-L	(150)		-32-L	(150)

Male Pipe	111504D-24-L	(50)	4.5	111607-24-L	(50)	7.5
x Male Pipe	-32-L	(50)	6.0	111472-32-L	(50)	10.0
Male Pipe	111504E-24-L	(50)		N/A		
x Swivel Male	-32-L	(50)		N/A		
Swivel Male	111504A-24-L	(50)		N/A		
x Female (2")	-32-L	(50)		N/A		
Male Pipe	111504C-24-L	(50)		N/A		
x Female (2")	-32-L	(50)		N/A		

Note #1: For assemblies shipped to Canada (ULC labels) add "C" suffix after length.

Example: 111398-24-0240C

Note #2: All assemblies should be suffixed with length. Example: 111404-24-0240(24"). Any length up to 24" is not available with UL mark.

Note #3: For suction applications consult factory.



Member of the T Group



TITEFLEX INDUSTRIAL AMERICAS

170 Tapley St., Springfield, MA 01104 USA

Telephone: 413-739-5631 FAX: 413-788-7593

Titeflex Industrial Americas (Local Fabrication)

1995 Peacock Boulevard, Oceanside, CA 92056 USA

Telephone: 619-721-4990 FAX: 619-721-0114

TITEFLEX EUROPE S.A. BP 93 Ozon La Ferrière, FRANCE

Telephone: 33-1-60027910 FAX: 33-1-60028334

CAST IRON



DG BOX WITH OUTSIDE DRAIN

TWO DOOR:

SIZE	PART #	NO CONTAINMENT
36"	36-23	
42"	42-23	
48"	48-23	
SIZE	PART #	5 GAL. - 1 RISER
36"	36-24	
42"	42-24	
48"	48-24	
SIZE	PART #	10 GAL. - 2 RISER 12" CENTERS
36"	36-25	
42"	42-25	(36, 42, 48-25 NON-RETURNABLE)
48"	48-25	
SIZE	PART #	10 GAL. - 2 RISER 14" CENTERS
36"	36-26	
42"	42-26	
48"	48-26	
SIZE	PART #	10 GAL. - 2 RISER 16" CENTERS
36"	36-27	
42"	42-27	
48"	48-27	
SIZE	PART #	15 GAL. - 2 RISER 16" CENTERS
36"	36-28	
42"	42-28	(36, 42, 48-28 NON-RETURNABLE)
48"	48-28	

FIL-SPIL CONTAINMENT

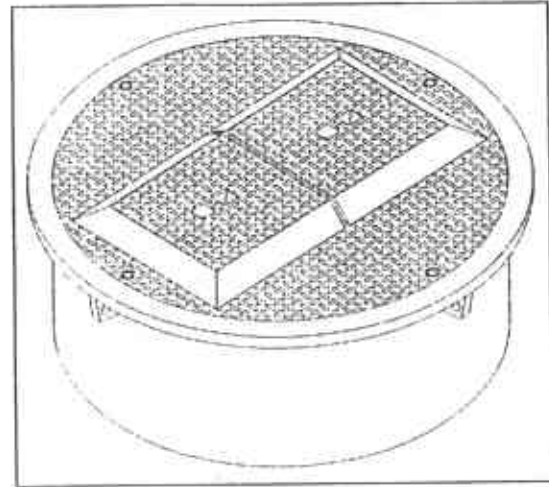

THREE DOOR:

SIZE	PART #	NO CONTAINMENT
42"	42-30	
48"	48-30	
SIZE	PART #	10 GAL. - 2 RISER 14" CENTERS
42"	42-31	
48"	48-31	
SIZE	PART #	10 GAL. - 2 RISER 16" CENTERS
42"	42-32	
48"	48-32	

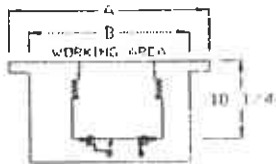
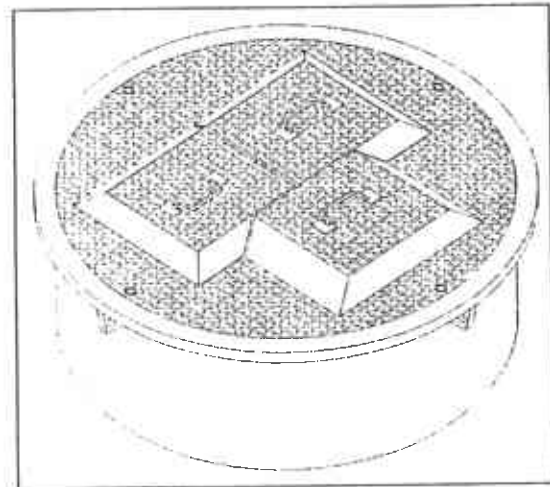

SEE PAGE 16 FOR OTHER DIMENSIONS

(NOTE: SPECIAL ORDER ITEMS AVAILABLE)

LEGEND - ADD LETTER TO PART # WHEN ANY OF THE FOLLOWING ARE REQUIRED:

F=FL SPEC. S=SNOW PLOW RING L=LA SPEC. H=HINGE COVER

O=7X7 OBSER. DOOR C=CAM LOK I=INLINE DRAIN

C.A.R.B. APPROVED

PATENT PENDING

15627 ARROW HIGHWAY • IRWINDALE, CA 91706

(818) 962 - 6646 • FAX: (818) 962 - 4854 • OUT OF STATE ONLY: 1-800-4CNI-MFG



TIGHT FILL ADAPTORS & CAPS-TOP SEAL



724

ADAPTOR - Threads onto fill pipe by means of internal wrenching lugs.

Model #	Cap Size	Pipe Size	Weight (lbs.)	Height	Width
724-3020	3"	2"	1.8	1 ³ / ₄ "	3 ⁵ / ₈ "
724-3030	3"	3"	1.0	1 ³ / ₄ "	3 ⁷ / ₈ "
724-4030	4"	3"	3.9	2"	4 ⁷ / ₈ "
724-4040	4"	4"	2.6	2 ³ / ₄ "	4 ⁷ / ₈ "

- Bronze construction
- Buna-N gasket included
- Compatible with Universal 726, 731 and 733 Caps

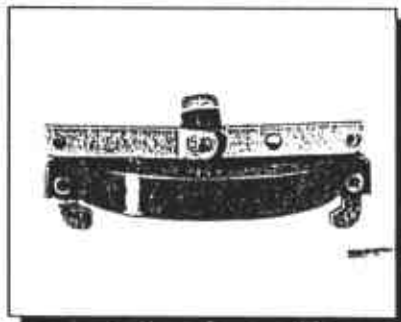

733

TOGGLE LEVER CAP - A lockable cap which features aluminum construction, zinc-plated steel arms, stainless steel cam-action levers, stainless steel pivot pins and a Buna-N seal.

Model #	Size	Weight (lbs.)	Height	Width
733-40	4"	1.7	2 ⁷ / ₈ "	7"

- Toggle action provides a positive, uniform seal
- Non-corrosive polymeric coating
- Color-coded grey for easy recognition and maintenance
- Compatible with 724 and 724CA Adaptors

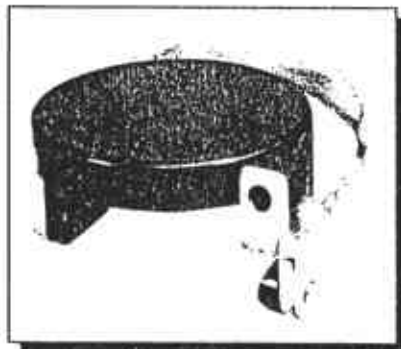

731

Patented 4,014,367
and 3,949,787

FLAT TOP CAP - A lockable cap which features a low profile design, which extends only ⁵/₈" above the adaptor. Allows maximum clearance in manhole installations, to compensate for ground heaving and settling. Aluminum construction with ductile iron cam-action handle and a Buna-N seal.

Model #	Size	Weight (lbs.)	Height	Width
731-40	4"	3.5	3 ¹ / ₂ "	7"

- Non-corrosive polymeric coating
- Color-coded grey for easy recognition and maintenance
- Compatible with 724 and 724CA Adaptors



VAPOR RECOVERY ACCESSORIES

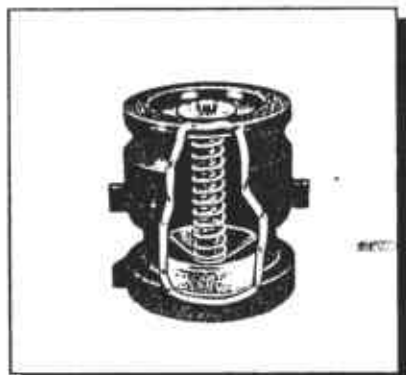

0611V

VAPOR CHECK VALVE ADAPTOR - A poppeted valve which seals vapor tight when uncoupled. Used for returning vapor to the tank truck during product drop.

Model #	Size	Weight (lbs.)	Height	Width
0611V-3030	3" x 3"	3.6	5 ¹ / ₁₆ "	5 ¹ / ₈ "
0611V-3040	3" x 4"	3.2	5 ¹ / ₈ "	5 ¹ / ₈ "

- Compatible with 0612VC, 0613VC and 0614VC Caps
- Aluminum hard-coated body for added corrosion protection
- Maximum working pressure is at 10 PSI

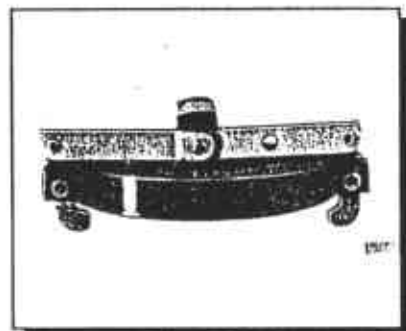

0614VC

TOGGLE LEVER CAP - A lockable cap which features aluminum construction, zinc-plated steel arms, bronze cam-action levers, stainless steel pivot pins and a Buna-N seal.

Model #	Size	Weight (lbs.)	Height	Width
0614VC-30	3"	1.7	2 ¹ / ₈ "	7"

- Toggle action provides a positive, uniform seal
- Non-corrosive polymeric coating
- Color-coded orange for easy recognition and maintenance
- Compatible with 0611V Vapor Check Valve Adaptor

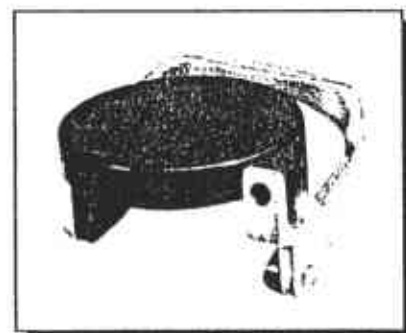

0613VC

Patented 4,014,367
and 3,949,787

FLAT TOP CAP - A lockable cap which features a low profile design, which extends only ⁷/₁₆" above the adaptor. Allows maximum clearance in manhole installations, to compensate for ground heaving and settling. Aluminum construction with ductile iron cam-action handle and a Buna-N seal.

Model #	Size	Weight (lbs.)	Height	Width
0613VC-30	3"	3.6	4"	7 ¹ / ₂ "

- Non-corrosive polymeric coating
- Color-coded orange for easy recognition and maintenance
- Compatible with 0611V Vapor Check Valve Adaptor

EMCO[®]
WHEATON

A1100 Guardian[™] Overfill Prevention Valve

Easy to Install in New and Existing Drop Tubes

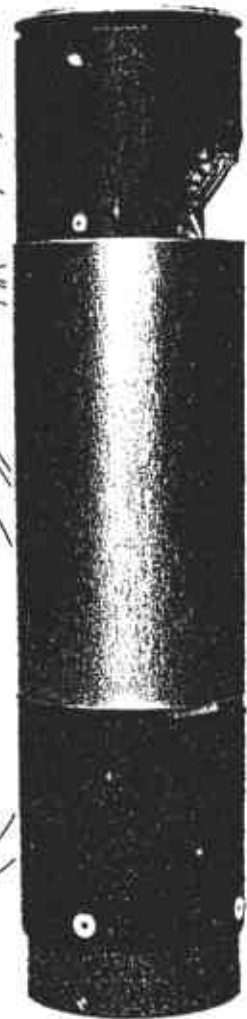
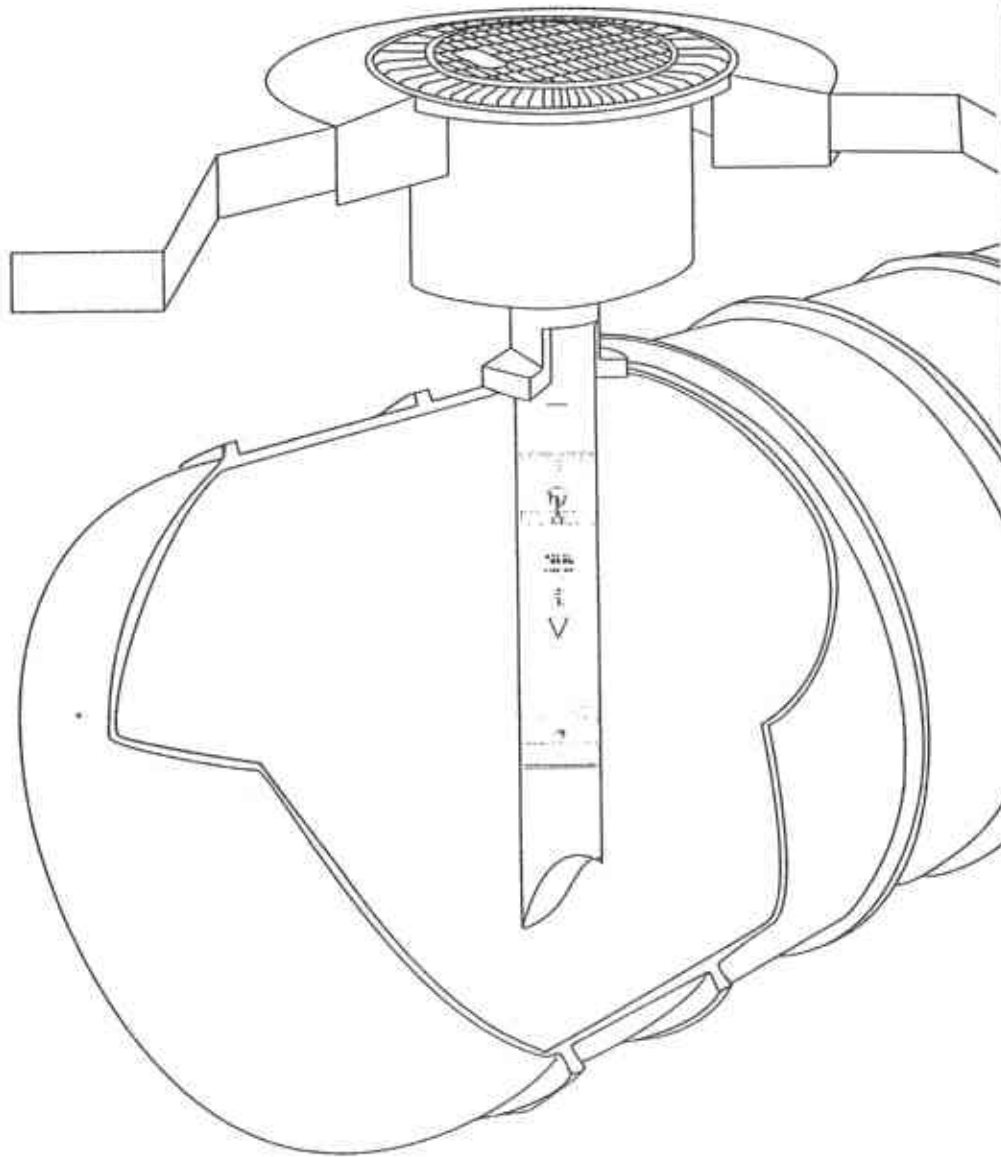

A1100 Guardian™ Overfill Prevention Valve

The Emco Wheaton A1100 is a two stage overfill prevention valve for use in both dual point and coaxial drop tubes. The A1100 is easily installed in a new or existing drop tube assembly for economical compliance with EPA regulations. This valve offers these outstanding features:

■ Has an internal float design, which eliminates any chance of the floats getting caught on the tank walls or the riser pipe. This design provides protection from damage during shipping and installation.

■ Is easier to install and remove than competitive products. Its slimline design makes it no wider

than a standard 4" drop tube. Simple installation saves time and reduces problems.

■ Works with both dual point and coaxial drop tubes, so you can order and stock one valve for all applications.

■ Will permit stick gauging at any tank capacity due to the automatic spring loaded poppet design.

■ Can be used with existing drop tubes and is sold separately for this purpose. It comes in a conveniently small package, which saves on shipping cost as well as storage space. *

■ Compatible with today's fuel additives.

* Thick wall drop tubes require Retrofit Adapter Kit #493418

Materials

Body:

Floats:

Poppet Seal:
Drain Poppet:

Description

Anodized
Aluminum
High Density
Polyethylene
Viton
Aluminum

Specifications

Weight: 4.5 lbs
Diameter: 3.76"
Length: 16.37"

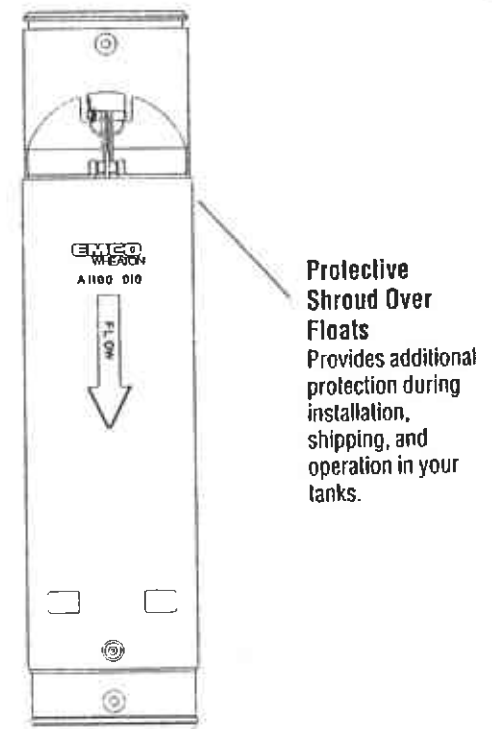
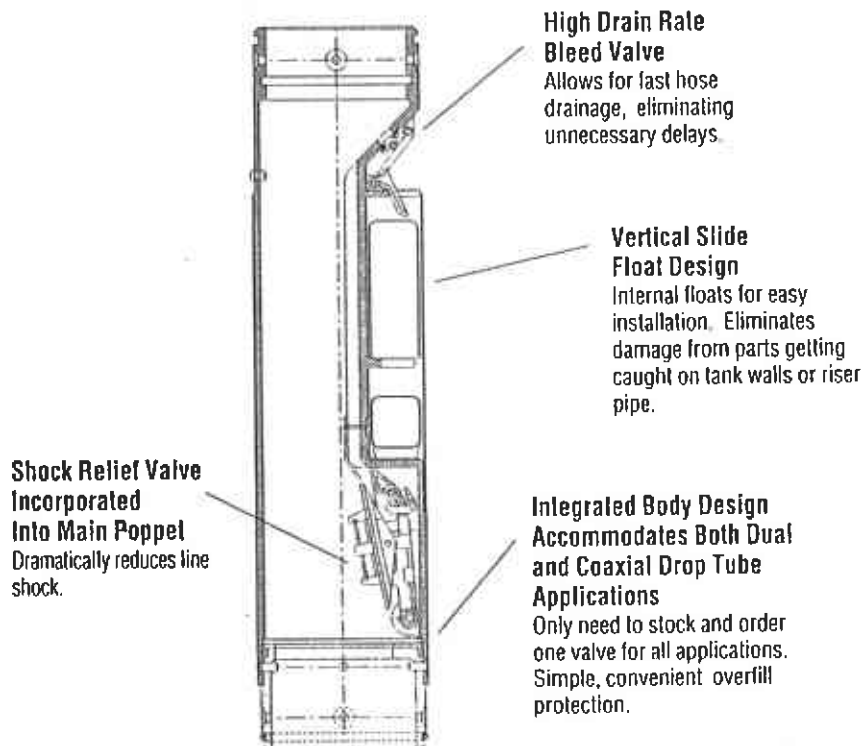

Distributed by:

Emco Wheaton, Inc.

4001 Weston Parkway

Cary, NC 27513

Tel: (800) 234-4394, (919) 677-0777

Fax: (919) 677-0632

Tight Fill Products

Drop Tubes

Emco Wheaton offers a range of drop tubes to match various fill system needs. These drop tubes are supplied in a variety of lengths and are designed to be altered in the field to meet specific tank dimensions. Installing drop tubes is fast and simple and requires no excavation. The drop tube is inserted in the riser pipe

until it touches the bottom of the tank. Next, the distance from the top of the tube or lugs to the top edge of the riser pipe is measured, and 3" is added. This length is then cut from the bottom of the drop tube at a 45° angle. The tube is inserted into the tank and is ready for use.

A20 Drop Tube



The A20 Drop Tube is used in conventional non-vapor recovery and dual point vapor recovery fill systems. The drop

tube fits directly into the tank riser pipe to permit tight fill submerged filling with reduced turbulence and minimal vapor loss. The A20 is constructed of light weight aluminum for easy

handling and installation. Complete with buna gasket. Cut 45° in the field to fit. Use with the A30 Fill Adapter and A97 Tight Fill Cap.

Model No.	Size	Length	Weight	Adapter*	Bushing*
A20-002	3"	11'	3 1/2 lbs.	A30-014	491689
A20-004	4"	12'	5 lbs.	A30-014	-
A20-006 (.065 Wall thickness)	4"	12'	5 lbs.	A30-014	-
A20-008	4"	14'	5 1/2 lbs.	A30-014	-

*Items must be ordered separately

A70 Coaxial Drop Tube



The A70 Drop Tube is used for coaxial vapor recovery tight fill systems and has a vapor recovery efficiency rated in excess of 95%.

The A70 tube design is narrow at the top but flares out to a standard tube size in the middle. This "vase" like design helps to decrease flow restric-

tion by actually creating a pull through effect in the system.

The A70 Drop Tube is to be used with the A96-001 Coaxial Tight Fill Adapter (order separately). A special 491689 reducer bushing is also required when using the 3" A70.

The A70 is constructed of light weight aluminum for easy handling. Cut to size in the field at a 45° angle for efficient flow.



Model No.	Size	Length	Weight	Adapter*	Bushing*
A70-001	4"	12'	12 lbs.	A96-001	-
A70-002	3"	12'	8 lbs.	A96-001	491689

*Items must be ordered separately



DOUBLE-POPET SAFETY VALVES

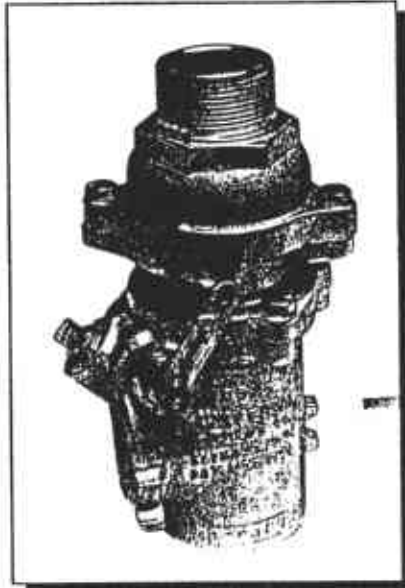

521DP

Male Shown

Patented 5,244,006

DOUBLE-POPET SAFETY VALVE - Features 3 distinct units - the standard lower main housing unit where the first poppet fits, the middle section containing the shear section and the top housing, which includes the second poppet. Pressure relief is built into the upper poppet to prevent pressure build up due to thermal expansion. If the Valve is hit, the upper poppet and lower valve body poppet both close and produce a 100% liquid tight seal - no product can escape from the dispenser's lower chamber onto the ground.

Model #	Size	Top Thread	Weight (lbs.)	Height	Width
521DP-RF-15	1 1/2"	Female	7.0	8 1/4"	4 1/2"
521DP-RM-15	1 1/2"	Male	7.0	8 1/4"	4 1/2"

NOTE: Double-poppet safety valves are also available for secondary containment.

Model #	Size	Top Thread	Weight (lbs.)	Height	Width
522DP-RF-15	1 1/2"	Female	7.0	8 1/4"	4 1/2"
522DP-RM-15	1 1/2"	Male	7.0	8 1/4"	4 1/2"
523DP-RF-15	1 1/2"	Female	7.0	8 1/4"	4 1/2"
523DP-RM-15	1 1/2"	Male	7.0	8 1/4"	4 1/2"

- Zinc-plating assures maximum corrosion resistance
- Stainless steel shaft and spring construction provide added reliability
- Ears and raised bosses allow secure valve anchoring
- Can be anchored by using the 521KR U-Clamp Anchor
- UL listed 195P

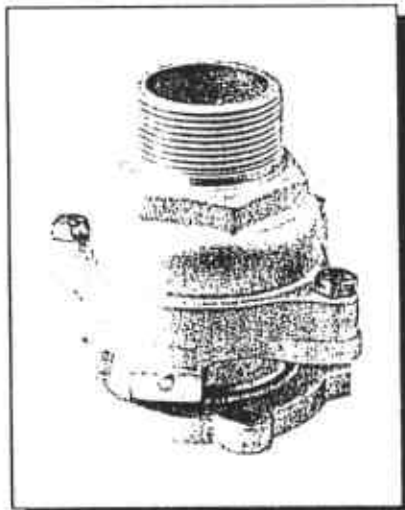

521DP

Top and Shear Section

REPLACEMENT TOPS - Should an original double-poppet safety valve top become damaged, Universal offers replacement tops.

Model #	Top Thread	Weight (lbs.)
521DP-RF-15-C	Female	2.0
521DP-RM-15-B	Male	1.8

REPLACEMENT SHEAR SECTION - Should an original double-poppet safety valve be sheared, Universal offers replacement shear sections.

Model #	Weight (lbs.)
521DP-SS-15	1.5

NOTE: Double-poppet safety valve replacement tops and replacement shear sections are ordered separately.

UNDER DISPENSER HOLD DOWN BOXES FOR SINGLE AND DUAL DISPENSERS

* ADD -2 TO PART NUMBERS FOR A DUAL HOLD DOWN BOX

CNI P/N	12" X 11" MAKE AND PART NUMBER
* 1011	GASBOY : 215 , 216 14-1/2" X 14"
* 1314	BENNETT : 3700 , 4000 , 4100 , 6012 , 6013 , 6022 , 6024 , 6025 , 6027 GASBOY : 53 , 52 SOUTHWEST : 435 , 440 , 2100 WAYNE : 14-1/2" X 19-3/4"
* 1320	BENNETT : 3900, 4000 GILBARCO : HIGHLINE 21" FRAME TOKHEIM : 220, 222, 333 14-1/2" X 21"
* 1321	BENNETT : 7011, 7012, 7022, 7024, 7111, 7112, 7122, 7124, 7211, 7212, 7222, 7224, 7312 7312, 7322, 7324, 4522 GASBOY : 150, 150S, 8552, 8553RDX, 8752, 8753B&D, 8852, 8853B&D GILBARCO : 154-0, 154-3, 154-R, 154-S, 164, 164-0, 164-3, 164-R, 164-S, 251-0, 252-0, 261-0 262-0, 625-3, 625-R, 625-S, 655-3, 684-R, 684-S, 1921, 4921, 5921, 6921, SALEMAKER4 SOUTHWEST : 435 TWIN, 440, 610, 640, 650, 661, 662, 2100MLPC TOKHEIM : 162, 262, 785, 1150, 1248, 1250 WAYNE : 160, 357, 358, 360, 361, 362, 363, 369, 370, 373, 379, 387, 710, 712 14-1/2" X 24"
* 1324	BENNETT : 7811, 7812 GASBOY : 2150, 8053, 8553ARDX, 8753TW, 9140RDX, 9152TW, 9153RDX GILBARCO : 251, 252-R, 261, 262, 262-R, 625-N, 655, 656-3, 656-R, 2921, 3921, 5625-U, 5627-W, HIGHLINE 100 27" FRAME WAYNE : 371, 372, 375, 585 14-1/2" X 28"
* 1328	SOUTHWEST : 2PD, 2+2MLPC, 2300, 4100, 4110, 4200, 4220, TOKHEIM : 2200 WAYNE : 386, 387, 389



WHEN ORDERING CONTAINMENT BOXES, YOU MUST ALSO ORDER P/N 317DT FOR EACH CONDUIT AND V.R. ENTRY

317DT	1" DOUBLE TAP COMPRESSION FITTING FOR EACH CONDUIT AND V.R. ENTRY
701	BOSS TYPE BRACKET (OLD STYLE)
702	U-CLAMP STYLE BRACKET
703	BOSS TYPE BRACKET (LAB TESTED FOR SHEAR)
UNO	ADD THE LETTERS UNO, FOR UNOCAL SPECS
BC1**	ADD TO P/N FOR 1 PRODUCT CONTAINMENT (BOTTOM ENTRY)
BC2**	ADD TO P/N FOR 2 PRODUCT CONTAINMENT (BOTTOM ENTRY)
SC1**	ADD TO P/N FOR 1 PRODUCT CONTAINMENT (SIDE ENTRY)
SC2**	ADD TO P/N FOR 2 PRODUCT CONTAINMENT (SIDE ENTRY)
SE	ADD TO P/N TO ORDER SIDE ENTRY HOLD DOWN BOX (NO CONTAINMENT)
SEO	ADD TO P/N TO ORDER SIDE ENTRY W/OBSERVATION BOX (NO CONTAINMENT)

* SINGLE PRODUCT HOLD DOWN BOXES WITH NO CONTAINMENT ARE STANDARD. TO ORDER A DUAL HOLD DOWN BOX, YOU NEED TO ADD -2 TO PART NUMBERS. REFER TO PAGE 1 OF PRICE LIST FOR DUAL PRICING.

** SEE PAGE 3 OF PRICE LIST.

CNI MFG. DOES NOT RECOMMEND, OR GUARANTEE IMPACT SHEAR ON AN UNDER-DISPENSER BOX WITHOUT CONTAINMENT USING A "U" STYLE CLAMP. TESTING HAS PROVEN IT WILL NOT SHEAR OFF DURING IMPACT BECAUSE OF THE EXISTING BRACKET.

UNDER DISPENSER HOLD DOWN BOXES FOR SINGLE AND DUAL DISPENSERS

SPECIFICATIONS:

BOX: 14 gauge steel, all meeting points of box welded for one piece construction

TIE DOWN: 2" uni-strut for impact valve tie down, box type brackets for leveling, boss type impacts only

BRACKETS: New style holding brackets have been tested by: NATIONAL TECHNICAL SYSTEMS, and have passed the shear test. You must add #703 to p/n for tested bracket

FEATURES:

- * 1" adjustment in either direction
- * Prevents product risers from pulling up when dispenser is hit
- * Holds impacts sturdy for shearing even with flex connectors, we do not recommend u style impact with flex connectors
- * Box type leveling brackets
- * Welded nuts for quick anchoring of dispenser
- * All hardware included

CNI MFG. DOES NOT RECOMMEND, OR GUARANTEE IMPACT SHEAR ON AN UNDER-DISPENSER BOX WITHOUT CONTAINMENT USING A "U" STYLE CLAMP. TESTING HAS PROVEN IT WILL NOT SHEAR OFF DURING IMPACT BECAUSE OF THE EXISTING BRACKET.

PATENT # 4,926,899

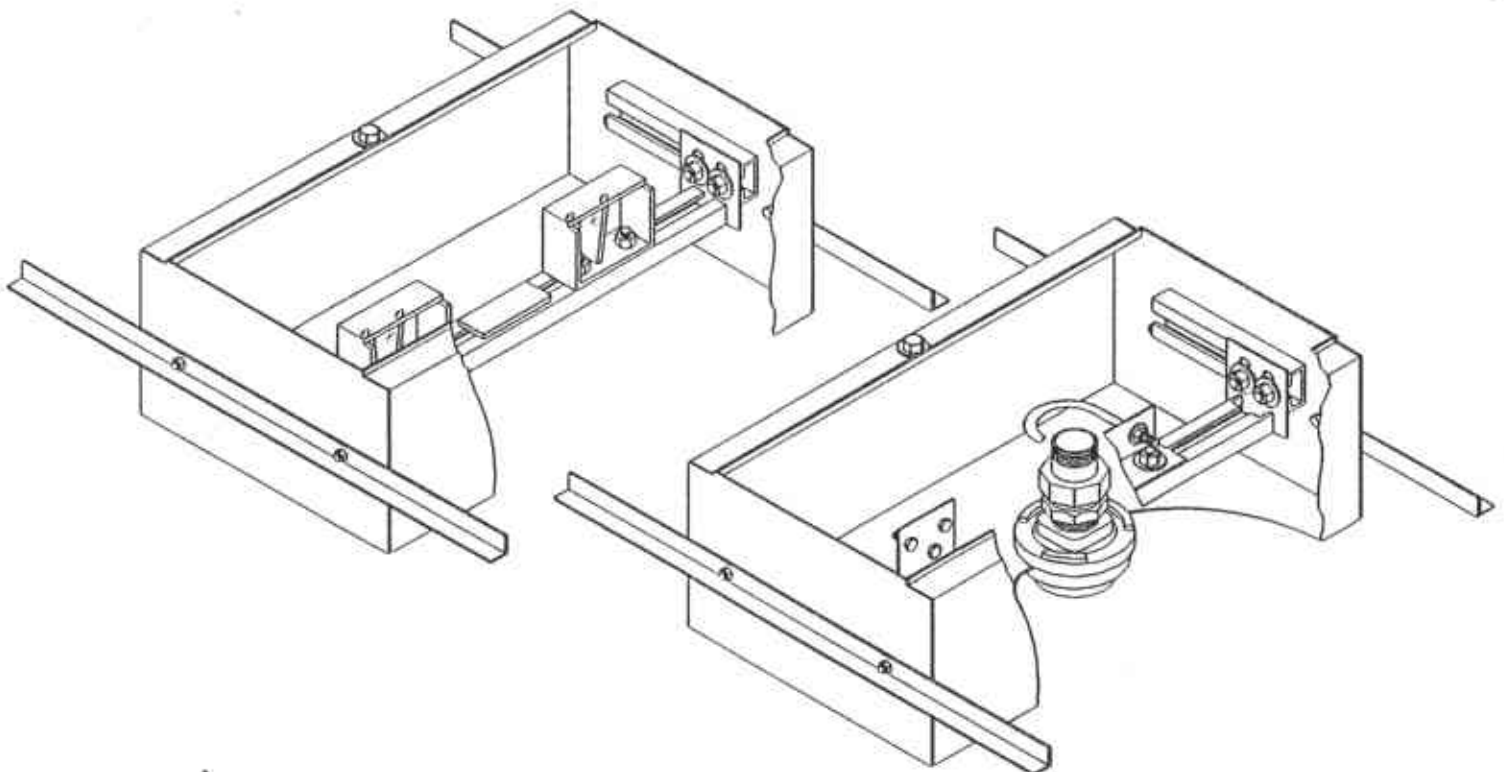

WITHOUT CONTAINMENT

WITH CONTAINMENT

IMPACT VALVE NOT INCLUDED
· CAN BE ORDERED WITH OR WITHOUT CONTAINMENT



UNISEAL

SEE PAGE 6 FOR SIZE
AND PART NUMBER

SEE PAGE 8 FOR IMPACT VALVE BOX PART NUMBERS

PLEASE USE P/N 703 FOR TESTED BOX TYPE BRACKET (PER EACH IMPACT)

Round Manholes

These manholes are available in 3 sizes: a 7-1/2" with a cast iron skirt, and a 12" or 18" with a welded steel skirt. All 3 sizes are offered with a cast iron cover. The 18" manhole is also available with our rugged, color coded, fiber reinforced covers. These manholes have a proven track record of trouble-free operation and the durable construction withstands the heaviest traffic. These manholes have been tested and meet the requirements of a D.O.T. H-20 load rating. The deep skirt depths allow the fill cap to be positioned above the fill dirt level even in thick concrete.

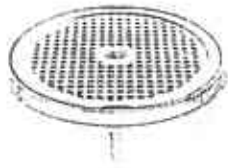

7-1/2" Manhole

Features	Part no.	Description	Skirt (dia./depth)	Lbs.
Ribbed cast iron cover	781-208-08	cast iron cover & skirt	7.50 x 8.00	22.81
Cast iron skirt	Cover (only)			
	781-402-01	cast iron		5.75



12" Manhole

Features	Part no.	Description	Skirt (dia./depth)	Lbs.
Ribbed cast iron cover	781-212-08	cast iron cover & skirt	12.00 x 8.50	31.00
	781-212-08-H	cast iron cover w/ handle & skirt	12.00 x 8.50	32.00
Heavy duty cast iron ring & 16 gauge welded steel skirt	781-212-12	cast iron cover & skirt	12.00 x 12.00	36.00
	Covers (only)			
	781-400-01	cast iron		17.00
	781-407-01	cast iron w/ handle		18.00

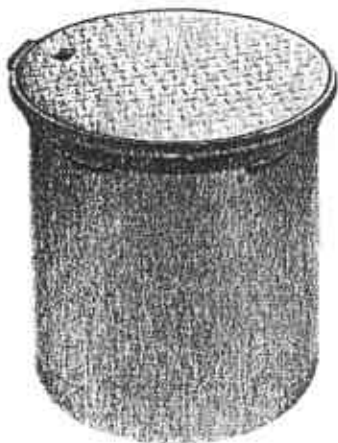

18" Manhole

Features	Part no.	Description	Skirt (dia./depth)	Lbs.
3/8" steel or fiber reinforced cover	781-318-08	3/8" steel cover & skirt	18.00 x 8.50	54.00
	781-318-12	3/8" steel cover & skirt	18.00 x 12.00	56.00
	781-318-18	3/8" steel cover & skirt	18.00 x 18.00	62.00
Heavy duty cast iron ring & 16 gauge welded steel skirt	781-418-08	fiber reinforced cover & skirt	18.00 x 8.50	30.00
	781-418-12	fiber reinforced cover & skirt	18.00 x 12.00	33.00
	781-418-18	fiber reinforced cover & skirt	18.00 x 18.00	39.00
	Covers (only)			
	781-304-01	black - fiber reinforced		10.00
	781-304-02	white - fiber reinforced		10.00
	781-304-03	red - fiber reinforced		10.00
	781-304-04	blue - fiber reinforced		10.00
	781-304-05	yellow - fiber reinforced		10.00
	781-304-06	gray - fiber reinforced		10.00
	781-304-07	orange - fiber reinforced		10.00
	781-306-01	3/8" diamond back steel		33.00



Manhole Specifications

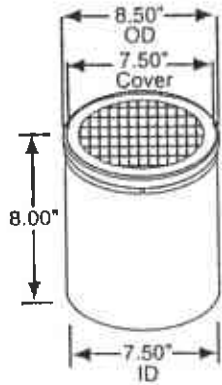

7-1/2" Manhole

Part no.	Assembly parts
781-402-01	cover
781-403-01	skirt

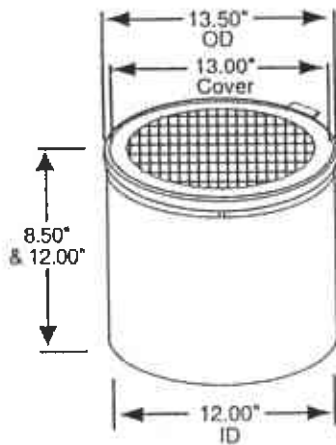

12" Manhole

Part no.	Assembly parts
781-400-01	cover
781-407-01	cover (with handle)
781-300-01	skirt (8.50)
781-300-04	skirt (12.00)

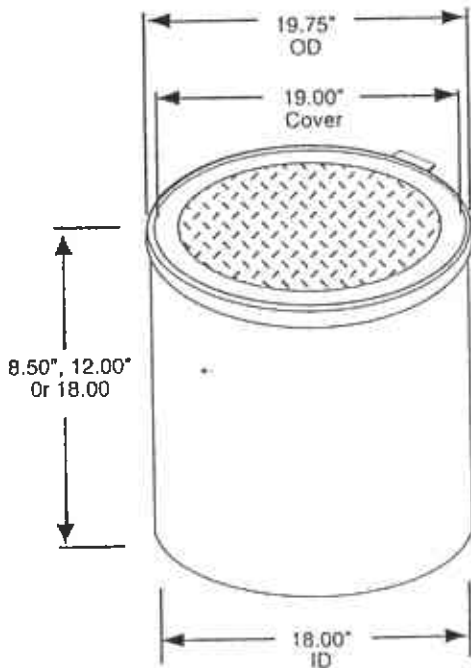

18" Manhole

Part no.	Assembly parts
781-304-01	cover (black - fiber reinforced)
781-304-02	cover (white - fiber reinforced)
781-304-03	cover (red - fiber reinforced)
781-304-04	cover (blue - fiber reinforced)
781-304-05	cover (yellow - fiber reinforced)
781-304-06	cover (gray - fiber reinforced)
781-304-07	cover (orange - fiber reinforced)
781-306-01	cover (3/8" diamond back steel)
781-300-03	skirt (8.50)
781-300-05	skirt (12.00)
781-300-02	skirt (18.00)



2814 McCracken Avenue Muskegon, MI 49441
 Order Desk 800 475-3291 • Sales Fax 800 475-4329 • Phone 616 755-1671

SUPER ERECTA SHELF® Metroseal™ Shelving

Every Metroseal shelf and post is backed by a limited 5-year warranty against surface rust formation.



Split Sleeves

Cat. No. Metroseal	Width		Length		Approx. Pkd. Wt.	
	(in.)	(mm)	(in.)	(mm)	(lbs.)	(kg)
1424NK	24	610	6	2.7	6	2.7
1430NK	30	760	7	3.2	7	3.2
1436NK	36	910	8	3.6	8	3.6
1442NK	42	1060	9	4.1	9	4.1
1448NK	48	1220	10 1/2	4.8	10 1/2	4.8
1460NK	60	1525	14	6.4	14	6.4
1472NK	72	1825	17	7.7	17	7.7
1824NK	24	610	7 1/2	3.2	7 1/2	3.2
1830NK	30	760	8	3.6	8	3.6
1836NK	36	910	9 1/2	4.3	9 1/2	4.3
1842NK	42	1060	11	5.0	11	5.0
1848NK	48	1220	12	5.4	12	5.4
1854NK	54	1370	14 1/2	6.6	14 1/2	6.6
1860NK	60	1525	17	7.7	17	7.7
1872NK	72	1825	20	9.1	20	9.1
2124NK	24	610	8	3.6	8	3.6
2130NK	30	760	9	4.1	9	4.1
2136NK	36	910	11	5.0	11	5.0
2142NK	42	1060	12	5.4	12	5.4
2148NK	48	1220	14	6.4	14	6.4
2154NK	54	1370	16	7.6	16	7.6
2160NK	60	1525	18	8.2	18	8.2
2172NK	72	1825	24	10.9	24	10.9
2424NK	24	610	9	4.1	9	4.1
2430NK	30	760	11	5.0	11	5.0
2436NK	36	910	13	5.9	13	5.9
2442NK	42	1060	15	6.8	15	6.8
2448NK	48	1220	16	7.3	16	7.3
2454NK	54	1370	18	8.6	18	8.6
2460NK	60	1525	21	9.5	21	9.5
2472NK	72	1825	26	11.8	26	11.8

Posts

Height*	Approx. Pkd. Wt.		Cat. No. Metroseal	
	(in.)	(mm)		(lbs.)
14 1/2	368	1	0.5	13PK
34 1/2	877	2	0.9	33PK
54 7/8	1386	3	1.4	54PK
62 1/8	1589	3 1/2	1.6	63PK
74 1/2	1895	4	1.8	74PK
86 1/2	2200	5	2.3	86PK

*Height includes leveling bolt and cap

Important: When ordering by components, remember that stability decreases as the ratio of height to width increases. Units should be kept as wide and low as possible.

METRO

InterMetro Industries Corporation
Wilkes-Barre, PA 18705

SUPER ERECTA SHELF® Metroseal™ Shelving

- **Attractive, Corrosion-Resistant Finish:** Developed by Metro to protect shelving against corrosive atmospheres found in walk-in coolers.
- **Economical:** Metroseal™ products are more economical than stainless steel for use in atmospheres which tend to corrode metals.
- **Super Erecta Shelf® Design:** Provides fast, secure assembly of unit without the use of any special tools; shelf adjustability at 1" intervals along the entire length of the post; versatile construction that can change as easily as your needs change; greater visibility of stored items and much more.
- **5-Year Limited Warranty** against rust formation.
- **The Process:** After a good, careful cleaning, nickel and chrome are applied to a carbon steel shelf or post. This plated piece is then treated to prepare it for coating. This extra step insures that the specially formulated epoxy will bind with the chrome.
- **The Drawing Depicts** a cross-section of two steel wires which have been welded together and protected by the Metroseal™ process.*

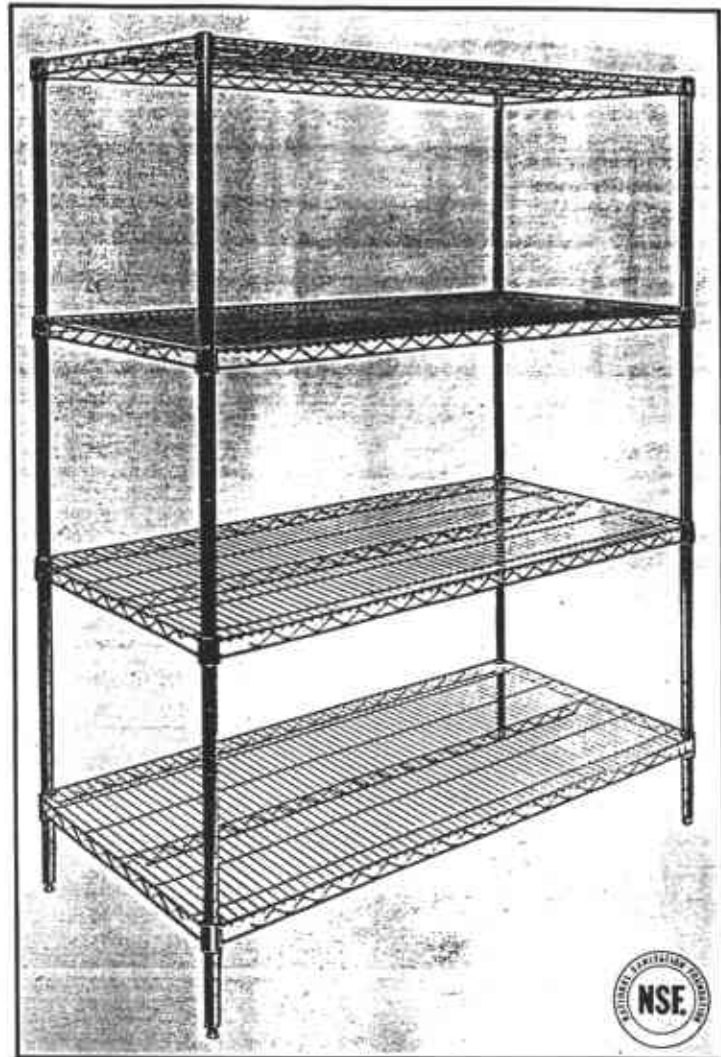

*U.S. Patent No. 4,285,783
Copyright © 1979 Metropolitan Wire Corp.

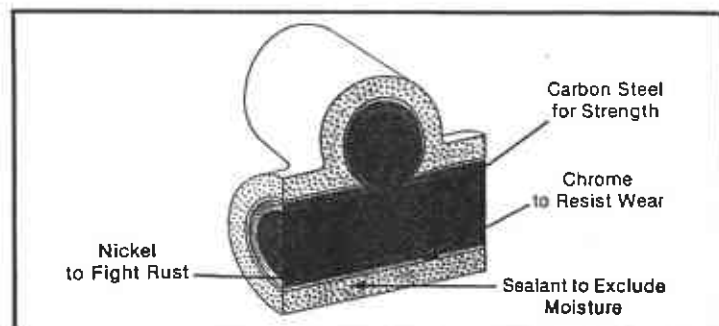

METRO

InterMetro Industries Corporation
Wilkes-Barre, PA 18705 • 717-825-2741

CATALOG SHEET
10.10